



**Features**

- Tx Output Power: 26dBm
- Tx Gain: 14dB
- Rx Insertion Loss: 1dB
- Antenna Diversity Switch

**Applications**

- Wireless Automated Metering
- Wireless Alarm Systems
- Portable Battery Powered Equipment
- Smart Energy

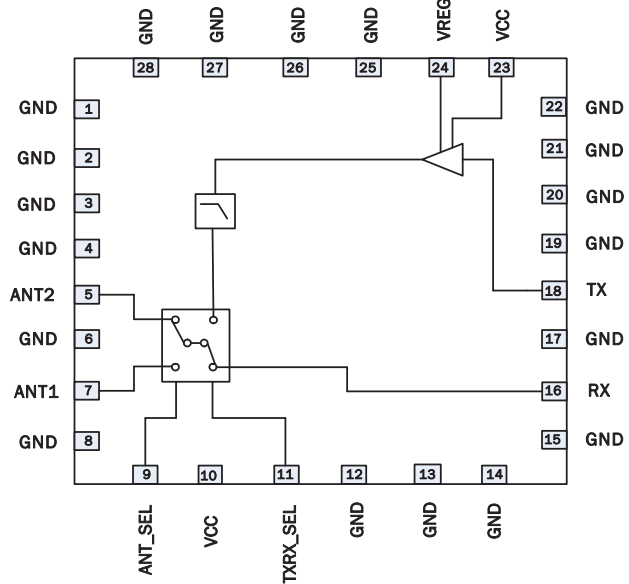

Functional Block Diagram

**Product Description**

This module is intended for 915MHz AMR solutions. It provides separate ports for Rx and Tx paths and two ports on the output for connecting a diversity solution or a test port. The PA section provides a nominal output power of 26dBm.

**Ordering Information**

- RF6599 ISM Band Transmit/Receive Module with Diversity Antenna Switch
- RF6599PCBK-410 Fully Assembled Evaluation Board and 5 loose pieces

**Optimum Technology Matching® Applied**

- |   |                                      |  |                                    |
|---|--------------------------------------|--|------------------------------------|
| <input type="checkbox"/> GaAs HBT             | <input type="checkbox"/> SiGe BiCMOS | <input checked="" type="checkbox"/> GaAs pHEMT | <input type="checkbox"/> GaN HEMT  |
| <input type="checkbox"/> GaAs MESFET          | <input type="checkbox"/> Si BiCMOS   | <input type="checkbox"/> Si CMOS               | <input type="checkbox"/> BiFET HBT |
| <input checked="" type="checkbox"/> InGaP HBT | <input type="checkbox"/> SiGe HBT    | <input type="checkbox"/> Si BJT                |                                    |

RF MICRO DEVICES®, RFMD®, Optimum Technology Matching®, Enabling Wireless Connectivity™, PowerStar®, POLARIS™ TOTAL RADIO™ and UltimateBlue™ are trademarks of RFMD, LLC. BLUETOOTH is a trademark owned by Bluetooth SIG, Inc., U.S.A. and licensed for use by RFMD. All other trade names, trademarks and registered trademarks are the property of their respective owners. ©2012, RF Micro Devices, Inc.

## Absolute Maximum Ratings

Parameter	Rating	Unit
Battery Voltage	5	V
RF Port Impedance	50	$\Omega$
Operating Temperature	-30 to 70	$^{\circ}\text{C}$
Storage Temperature	-40 to 85	$^{\circ}\text{C}$
ESD, HBM (RF pins)	500	V
ESD, HBM (All pins)	500	V
ESD, CDN (RF pins)	500	V
ESD, CDM (all pins)	500	V
MSL	MSL 3	
Maximum Input Power to PA*	+20	dBm

\* Maximum Input Power with a 50 $\Omega$  Load.



**Caution!** ESD sensitive device.

Exceeding any one or a combination of the Absolute Maximum Rating conditions may cause permanent damage to the device. Extended application of Absolute Maximum Rating conditions to the device may reduce device reliability. Specified typical performance or functional operation of the device under Absolute Maximum Rating conditions is not implied.

The information in this publication is believed to be accurate and reliable. However, no responsibility is assumed by RF Micro Devices, Inc. ("RFMD") for its use, nor for any infringement of patents, or other rights of third parties, resulting from its use. No license is granted by implication or otherwise under any patent or patent rights of RFMD. RFMD reserves the right to change component circuitry, recommended application circuitry and specifications at any time without prior notice.



RFMD Green: RoHS compliant per EU Directive 2002/95/EC, halogen free per IEC 61249-2-21, < 1000ppm each of antimony trioxide in polymeric materials and red phosphorus as a flame retardant, and <2% antimony in solder.

Parameter	Specification			Unit	Condition
	Min.	Typ.	Max.		
<b>Power Amplifier</b>					$V_{CC} = 3.6\text{V}$ , TXRX_SEL = HIGH, ANT_SEL = HIGH or LOW, $V_{REG} = \text{HIGH}$ , Temperature = 25 $^{\circ}\text{C}$
Frequency Range	902	915	928	MHz	
CW Output Power	25.5	26		dBm	
Large Signal Gain	10	14		dB	minimum with $V_{CC} = 3.3\text{V}$ , Temperature = 70 $^{\circ}\text{C}$
Output Harmonic Levels					
2nd	-30			dBc	
3rd through 10th	-67			dBc	
Input Return Loss		10		dB	
Power Supply Voltage					
$V_{CC}$	3.3	3.6	4	V	
$V_{REG}$	3.1	3.4	3.8	V	$V_{REG} = V_{CC} - 0.2\text{V}$
Current					
Operating $V_{CC}$		215	290	mA	$V_{CC} = 3.6\text{V}$ , $P_{OUT} = 26\text{dBm}$
Operating $V_{REG}$		3	4	mA	
Tx Idle Current		54	60	mA	$V_{CC} = 3.6\text{V}$ , $V_{REG} = 3.4\text{V}$ , ANT_SEL = TXRX_SEL = 3.4V at $P_{OUT} = 0\text{dBm}$
Module Leakage		0.2	0.5	$\mu\text{A}$	$V_{CC} = 3.6\text{V}$ TXRX_SEL, ANT_SEL and $V_{REG} = 0.0\text{V}$

Parameter	Specification			Unit	Condition
	Min.	Typ.	Max.		
<b>Rx Path</b>					$V_{CC} = 3.6V$ , TXRX_SEL = LOW, ANT_SEL = HIGH or LOW, $V_{REG} = LOW$
Frequency Range	902	915	928	MHz	
Insertion Loss		1	1.3	dB	
Input IP3	12	18		dBm	
Input Return Loss	10			dB	
Output Return Loss	10			dB	
Current					
ANT1		80		$\mu A$	ANT_SEL = HIGH, $V_{REG} = Low$ , TXRX_Sel = Low
Power Down Mode, ANT2		1.2		$\mu A$	ANT_SEL = LOW, $V_{REG} = Low$ , TXRX_Sel = Low
<b>Antenna Switch and Logic</b>					
Isolation	20			dB	Any used port to any unused port
Logic Voltage High	3.1	3.4	3.8	V	All Logic I/O's, $V_{CC}$ to 0.2V
Logic Voltage Low	0	0.2		V	All Logic I/O's
Logic Current, High		85	120	$\mu A$	All Logic I/O's

Operating Mode	Module Logic Truth Table	
	ANT_SEL	TXRX_SEL
TX - ANT1	HIGH	HIGH
TX - ANT2	LOW	HIGH
RX - ANT1	HIGH	LOW
RX - ANT2	LOW	LOW

## Pin Names and Descriptions

Pin	Name	Description
1	GND	Ground
2	GND	Ground
3	GND	Ground
4	GND	Ground
5	ANT2	Antenna 2 Output/Input
6	GND	Ground
7	ANT1	Antenna 1 Output/Input
8	GND	Ground
9	ANT_SEL	Antenna Selection Control Line
10	VCC	Diversity Switch Supply Voltage
11	TXRX_SEL	Transmit or Receive Selection Control Line
12	GND	Ground
13	GND	Ground
14	GND	Ground
15	GND	Ground
16	RX	Receive Port
17	GND	Ground
18	TX	Transmit Port
19	GND	Ground
20	GND	Ground
21	GND	Ground
22	GND	Ground
23	VCC	Power Amplifier Supply Voltage
24	VREG	Power Amplifier Supply Voltage
25	GND	Ground
26	GND	Ground
27	GND	Ground
28	GND	Ground
29	GND	Center Ground Flag

**Package Drawing**

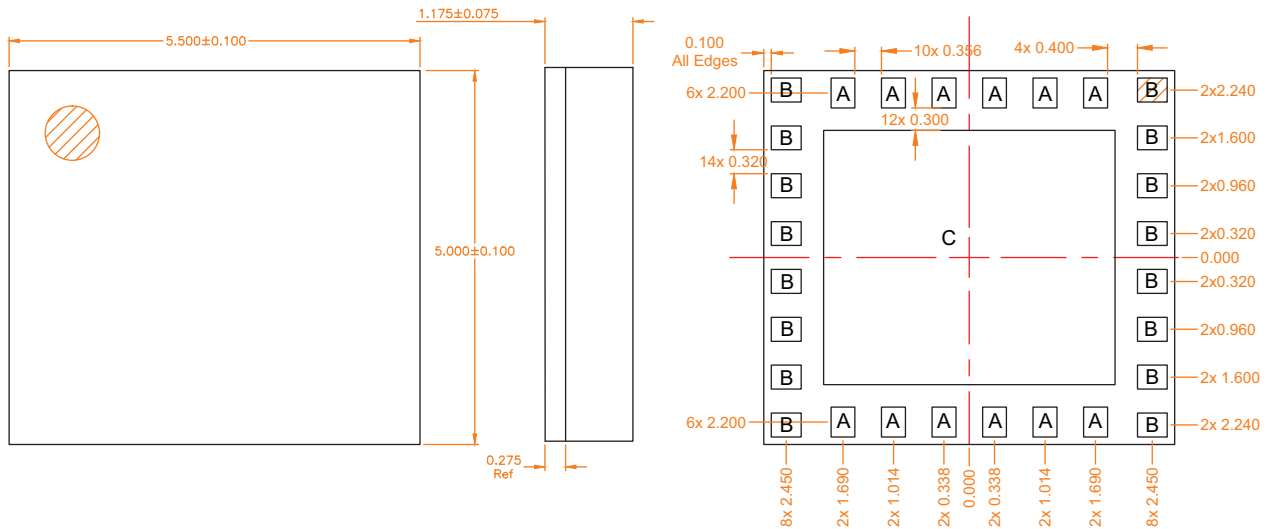

Notes:  
1. Shaded area represents Pin 1 location

A = 0.320 x 0.400 mm  
B = 0.400 x 0.320 mm  
C = 3.900 x 3.400 mm

All units in  $\mu\text{m}$ .

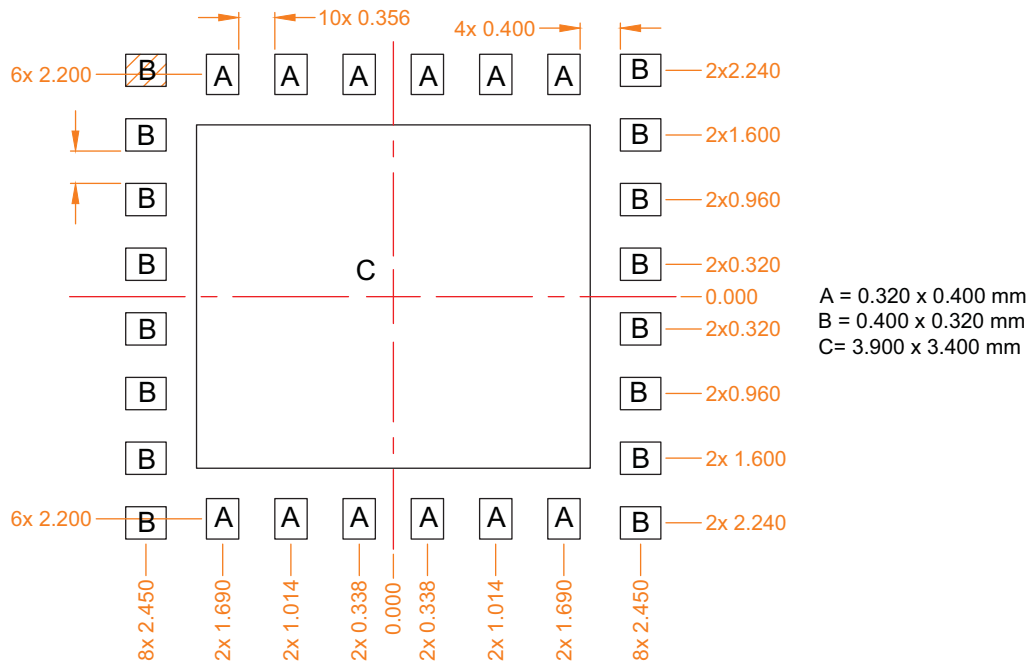

**PCB METAL LAND PATTERN**

1. Shaded area represents Pin 1 location

A = 0.320 x 0.400 mm  
B = 0.400 x 0.320 mm  
C = 3.900 x 3.400 mm

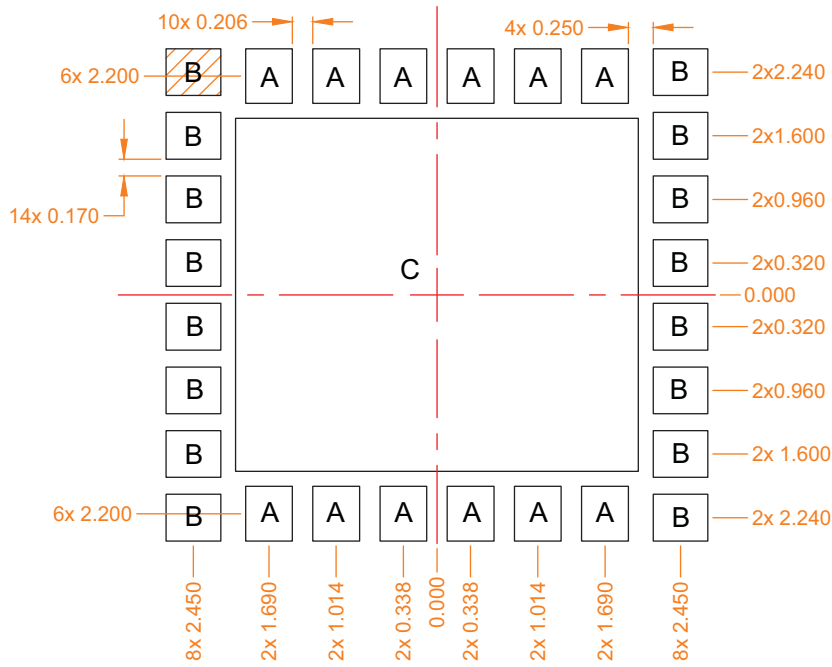

A = 0.470 x 0.550 mm  
 B = 0.550 x 0.470 mm  
 C = 4.050 x 3.550 mm

PCB SOLDER MASK PATTERN

1. Shaded area represents Pin 1 location

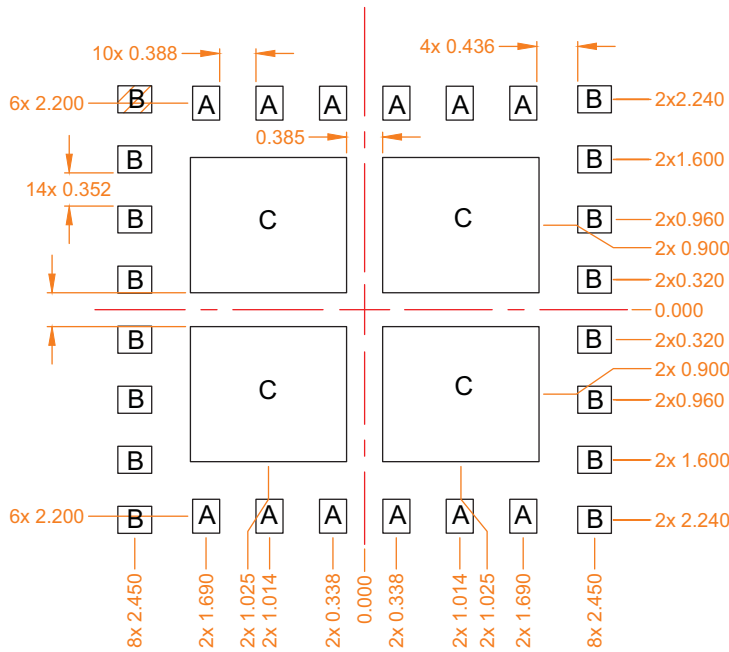

A = 0.288 x 0.360 mm  
 B = 0.360 x 0.288 mm  
 C = 1.665 x 1.440 mm

PCB STENCIL PATTERN

1. Shaded area represents Pin 1 location

**Pin Out**

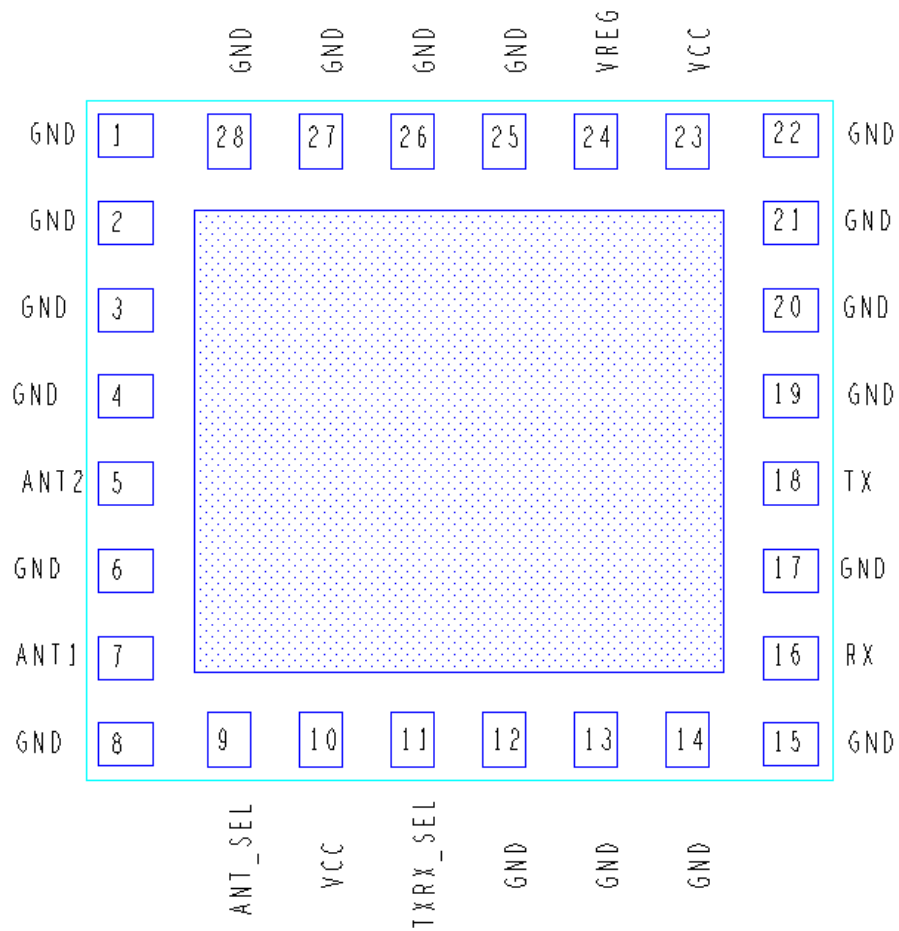

Evaluation Board Schematic

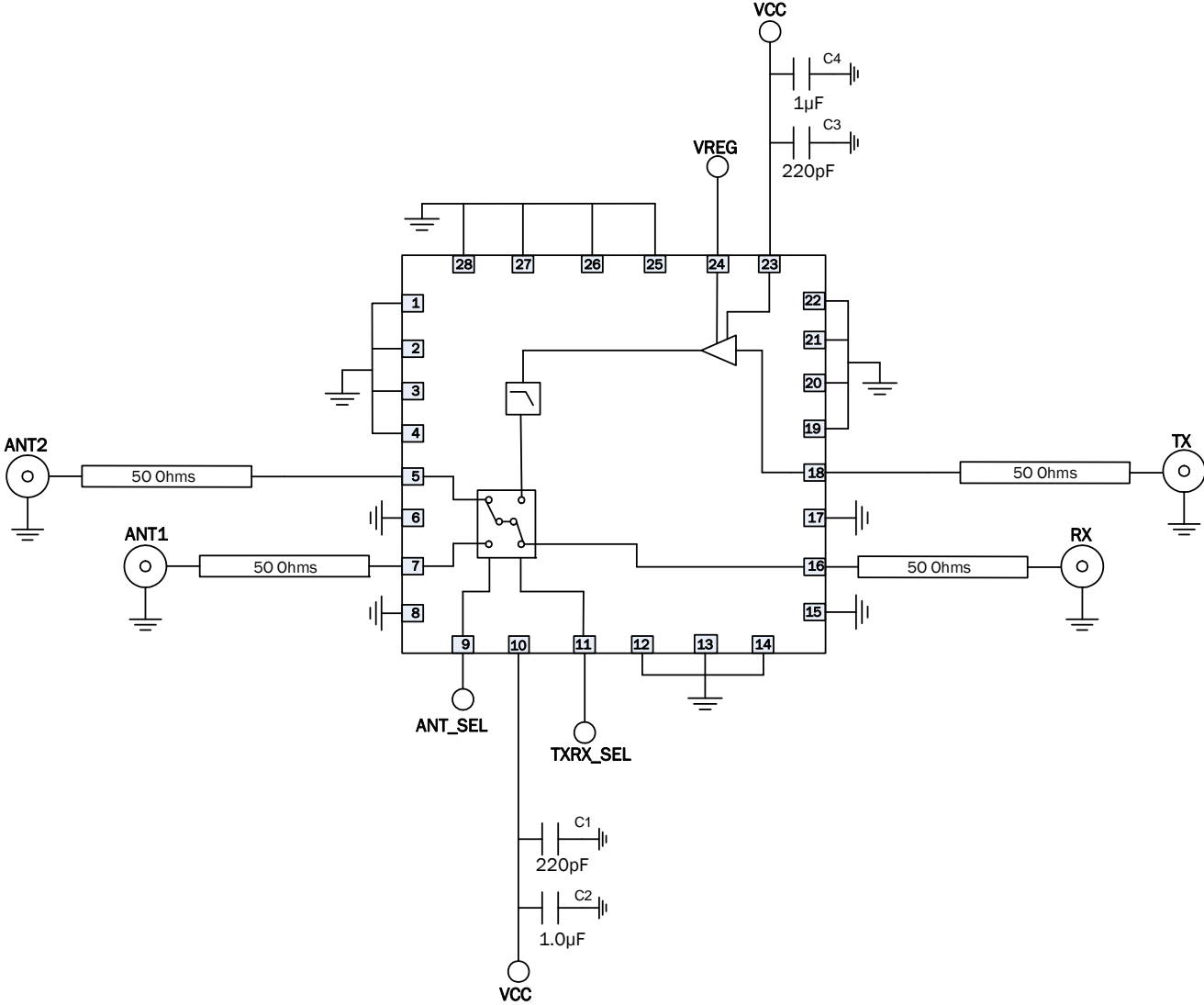

### Typical Performance

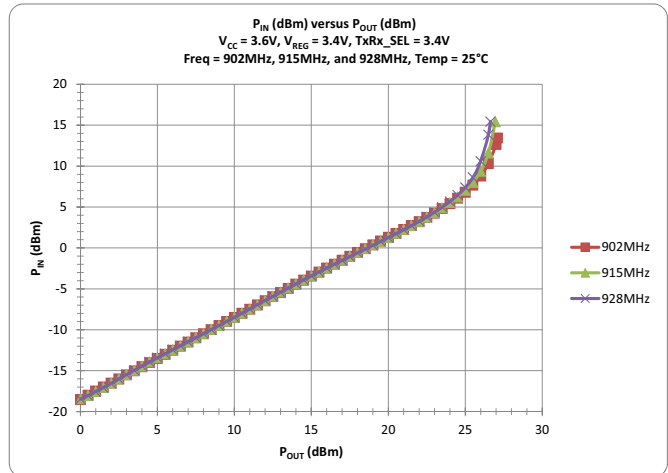
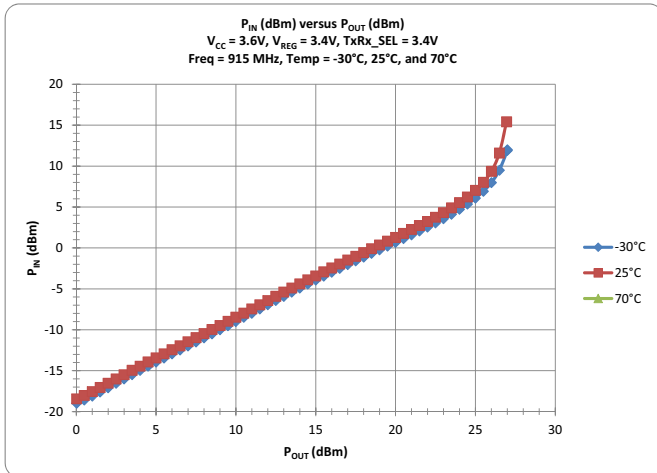
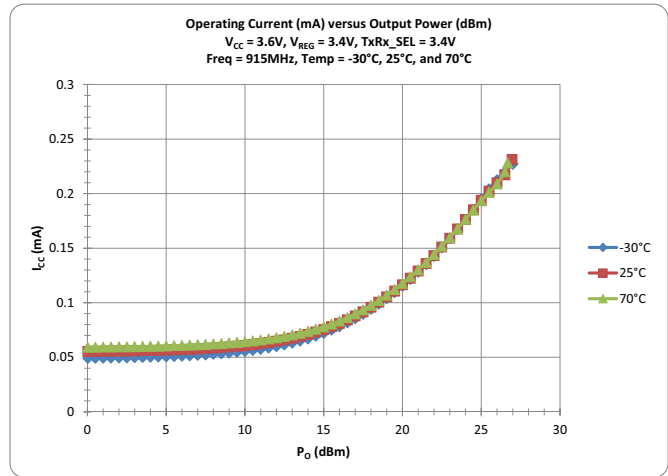
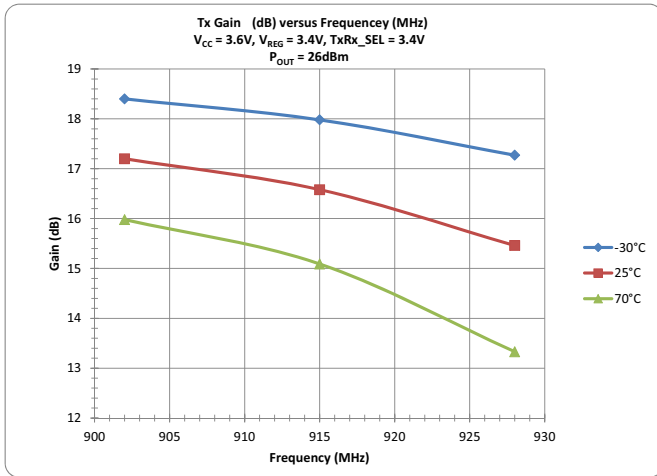
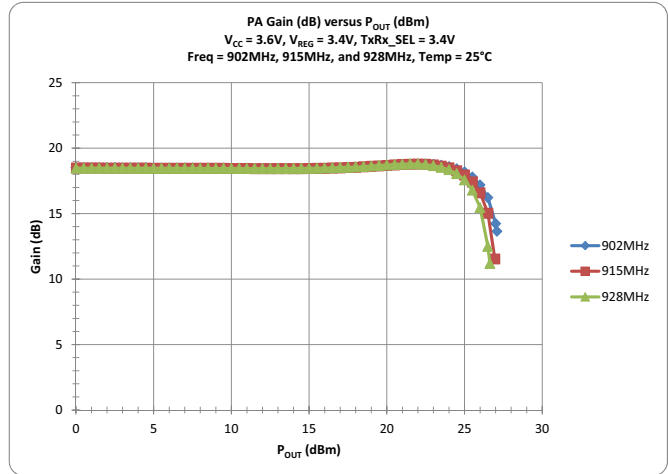
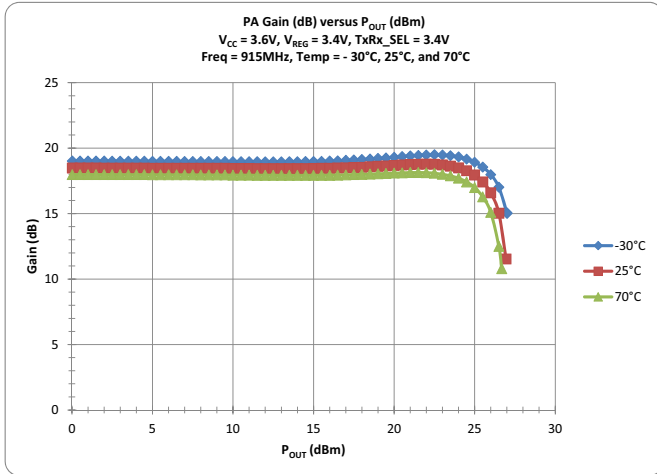

## Typical Performance

