



# RF Power Field Effect Transistor

## N-Channel Enhancement-Mode Lateral MOSFET

Designed for GSM 900 MHz frequency band, the high gain and broadband performance of this device make it ideal for large-signal, common-source amplifier applications in 26 volt base station equipment.

- Typical Performance for GSM Frequencies, 960 MHz, 26 Volts  
 Output Power @ P1db: 75 Watts  
 Power Gain @ P1db: 18.5 dB  
 Efficiency @ P1db: 55%
- Capable of Handling 5:1 VSWR, @ 26 Vdc, 921 MHz, 90 Watts CW Output Power

### Features

- Internally Matched for Ease of Use
- High Gain, High Efficiency and High Linearity
- Integrated ESD Protection
- Designed for Maximum Gain and Insertion Phase Flatness
- Excellent Thermal Stability
- Characterized with Series Equivalent Large-Signal Impedance Parameters
- Available with Low Gold Plating Thickness on Leads. L Suffix Indicates 40μ" Nominal.
- RoHS Compliant
- In Tape and Reel. R3 Suffix = 250 Units per 56 mm, 13 inch Reel.

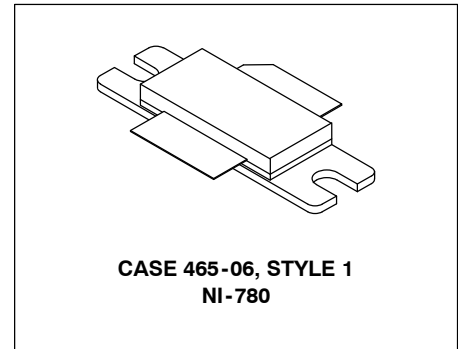
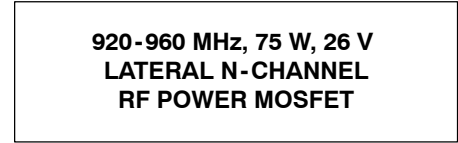

LIFETIME BUY

LAST ORDER 3 OCT 08 LAST SHIP 14 MAY 09

**Table 1. Maximum Ratings**

Rating	Symbol	Value	Unit
Drain-Source Voltage	V <sub>DSS</sub>	- 0.5, +65	Vdc
Gate-Source Voltage	V <sub>GS</sub>	- 0.5, +15	Vdc
Total Device Dissipation @ T <sub>C</sub> = 25°C Derate above 25°C	P <sub>D</sub>	250 1.43	W W/°C
Storage Temperature Range	T <sub>stg</sub>	- 65 to +150	°C
Case Operating Temperature	T <sub>C</sub>	150	°C
Operating Junction Temperature	T <sub>J</sub>	200	°C

**Table 2. Thermal Characteristics**

Characteristic	Symbol	Value	Unit
Thermal Resistance, Junction to Case	R <sub>θJC</sub>	0.7	°C/W

**Table 3. ESD Protection Characteristics**

Test Conditions	Class
Human Body Model	1 (Minimum)
Machine Model	M1 (Minimum)

**Table 4. Electrical Characteristics** ( $T_C = 25^\circ\text{C}$  unless otherwise noted)

Characteristic	Symbol	Min	Typ	Max	Unit
<b>Off Characteristics</b>					
Zero Gate Voltage Drain Leakage Current ( $V_{DS} = 65 \text{ Vdc}$ , $V_{GS} = 0$ )	$I_{DSS}$	—	—	10	$\mu\text{Adc}$
Zero Gate Voltage Drain Leakage Current ( $V_{DS} = 26 \text{ Vds}$ , $V_{GS} = 0$ )	$I_{DSS}$	—	—	1	$\mu\text{Adc}$
Gate-Source Leakage Current ( $V_{GS} = 5 \text{ Vdc}$ , $V_{DS} = 0$ )	$I_{GSS}$	—	—	1	$\mu\text{Adc}$
<b>On Characteristics</b>					
Gate Threshold Voltage ( $V_{DS} = 10 \text{ Vdc}$ , $I_D = 300 \mu\text{Adc}$ )	$V_{GS(th)}$	2.0	—	4.0	Vdc
Gate Quiescent Voltage ( $V_{DS} = 26 \text{ Vdc}$ , $I_D = 700 \text{ mAdc}$ )	$V_{GS(Q)}$	—	3.7	—	Vdc
Drain-Source On-Voltage ( $V_{GS} = 10 \text{ Vdc}$ , $I_D = 2 \text{ Adc}$ )	$V_{DS(on)}$	—	0.19	0.4	Vdc
Forward Transconductance ( $V_{DS} = 10 \text{ Vdc}$ , $I_D = 6 \text{ Adc}$ )	$g_{fs}$	—	8.0	—	S
<b>Dynamic Characteristics (1)</b>					
Output Capacitance ( $V_{DS} = 26 \text{ Vdc}$ , $V_{GS} = 0$ , $f = 1 \text{ MHz}$ )	$C_{oss}$	—	73	—	pF
Reverse Transfer Capacitance ( $V_{DS} = 26 \text{ Vdc}$ , $V_{GS} = 0$ , $f = 1 \text{ MHz}$ )	$C_{rss}$	—	2.9	—	pF
<b>Functional Tests</b> (In Freescale Test Fixture, 50 ohm system)					
Power Output, 1 dB Compression Point ( $V_{DD} = 26 \text{ Vdc}$ , $I_{DQ} = 600 \text{ mA}$ , $f = 960 \text{ MHz}$ )	$P_{1dB}$	68	75	—	W
Common-Source Amplifier Power Gain @ 70 W (Min) ( $V_{DD} = 26 \text{ Vdc}$ , $I_{DQ} = 600 \text{ mA}$ , $f = 960 \text{ MHz}$ )	$G_{ps}$	17	18.5	20	dB
Drain Efficiency @ $P_{out} = 70 \text{ W}$ ( $V_{DD} = 26 \text{ Vdc}$ , $I_{DQ} = 600 \text{ mA}$ , $f = 960 \text{ MHz}$ )	$\eta_1$	47	52	—	%
Drain Efficiency @ P1dB ( $V_{DD} = 26 \text{ Vdc}$ , $I_{DQ} = 600 \text{ mA}$ , $f = 960 \text{ MHz}$ )	$\eta_2$	—	55	—	%
Input Return Loss ( $V_{DD} = 26 \text{ Vdc}$ , $P_{out} = 70 \text{ W}$ , $I_{DQ} = 600 \text{ mA}$ , $f = 960 \text{ MHz}$ )	IRL	9.5	12.5	—	dB

1. Part is internally input matched.

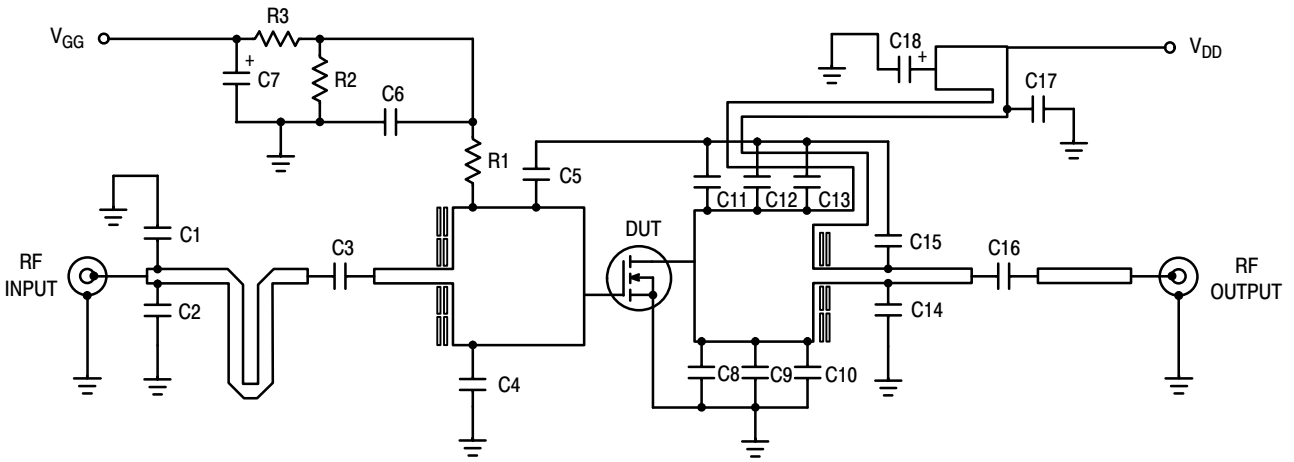
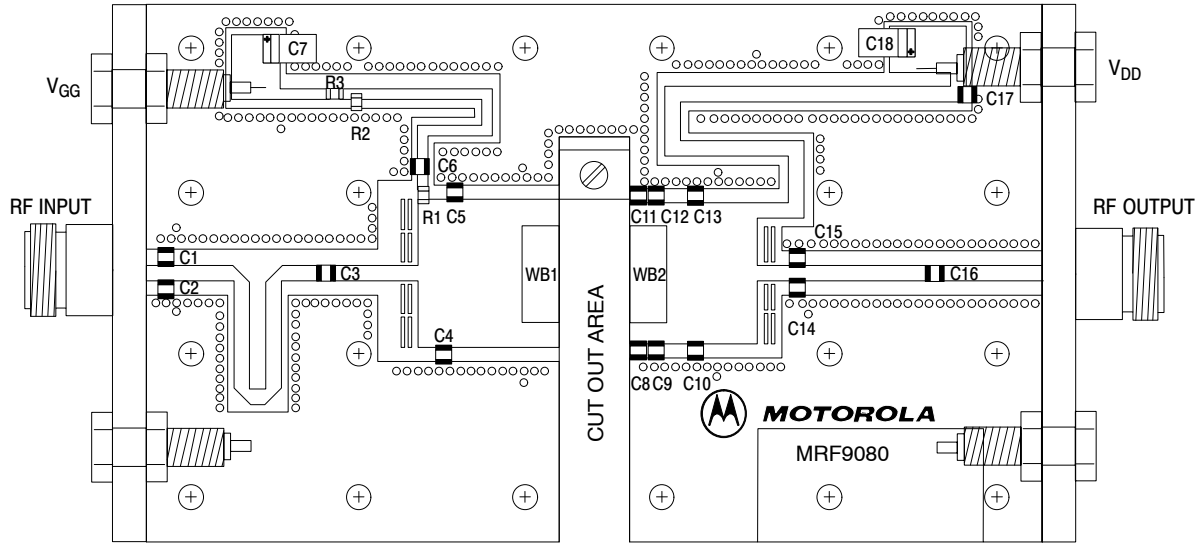

Figure 1. Broadband GSM 900 Test Circuit Schematic

Table 5. Broadband GSM 900 Test Circuit Component Designations and Values

Part	Description	Part Number	Manufacturer
C1	4.7 pF Chip Capacitor	ATC100B4R7BT500XT	ATC
C2	2.7 pF Chip Capacitor	ATC100B2R7BT500XT	ATC
C3	1.5 pF Chip Capacitor	ATC100B1R5BT500XT	ATC
C4, C5, C9, C10, C12, C13	5.6 pF Chip Capacitors	ATC100B5R6CT500XT	ATC
C6, C16, C17	22 pF Chip Capacitors	ATC100B220GT500XT	ATC
C7, C18	10 $\mu$ F, 35 V Tantalum Chip Capacitors	T491D106M035AT	Kemet
C8, C11	10 pF Chip Capacitors	ATC100B100JT500XT	ATC
C14	0.8 pF Chip Capacitor	ATC100B0R8BT500XT	ATC
C15	8.2 pF Chip Capacitor	ATC100B8R2GT500XT	ATC
R1, R2, R3	1.0 k $\Omega$ , 1/8 W Chip Resistors	CRCW08051001FKEA	Vishay
Raw PCB Material	30 mil Glass Teflon <sup>®</sup> , $\epsilon_r = 2.55$	TLX8-0300	Taconic



Freescale has begun the transition of marking Printed Circuit Boards (PCBs) with the Freescale Semiconductor signature/logo. PCBs may have either Motorola or Freescale markings during the transition period. These changes will have no impact on form, fit or function of the current product.

Figure 2. Broadband GSM 900 Test Circuit Component Layout

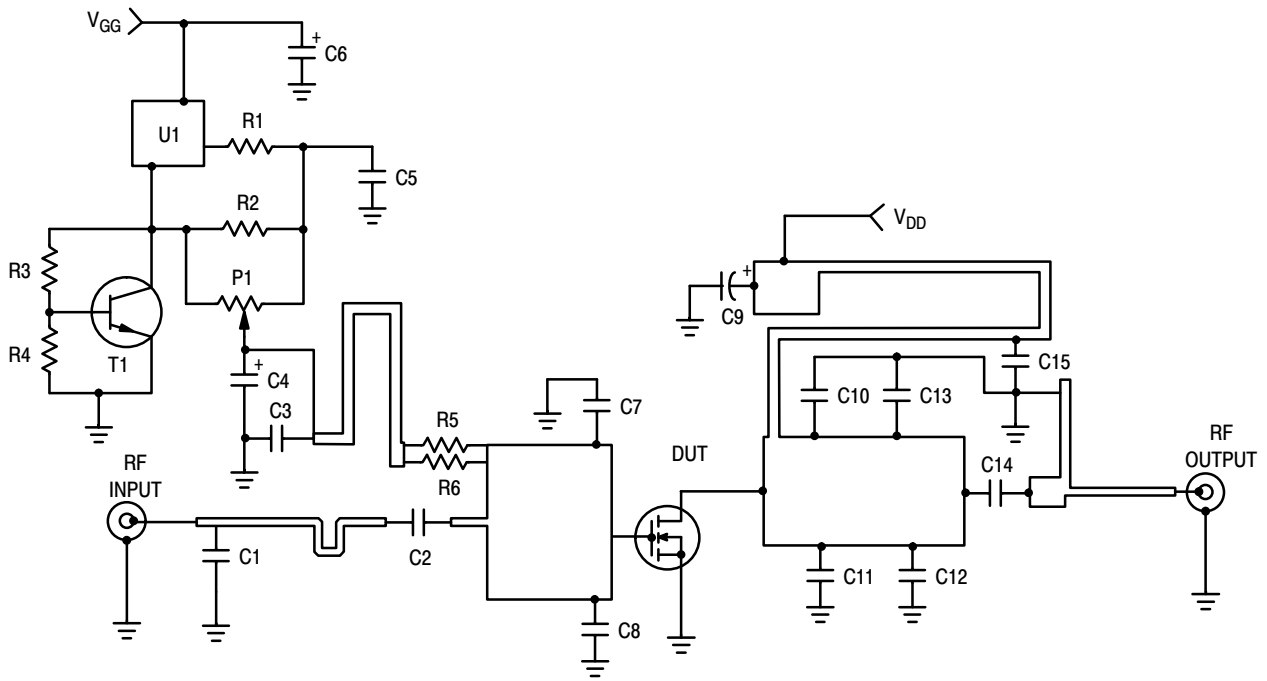
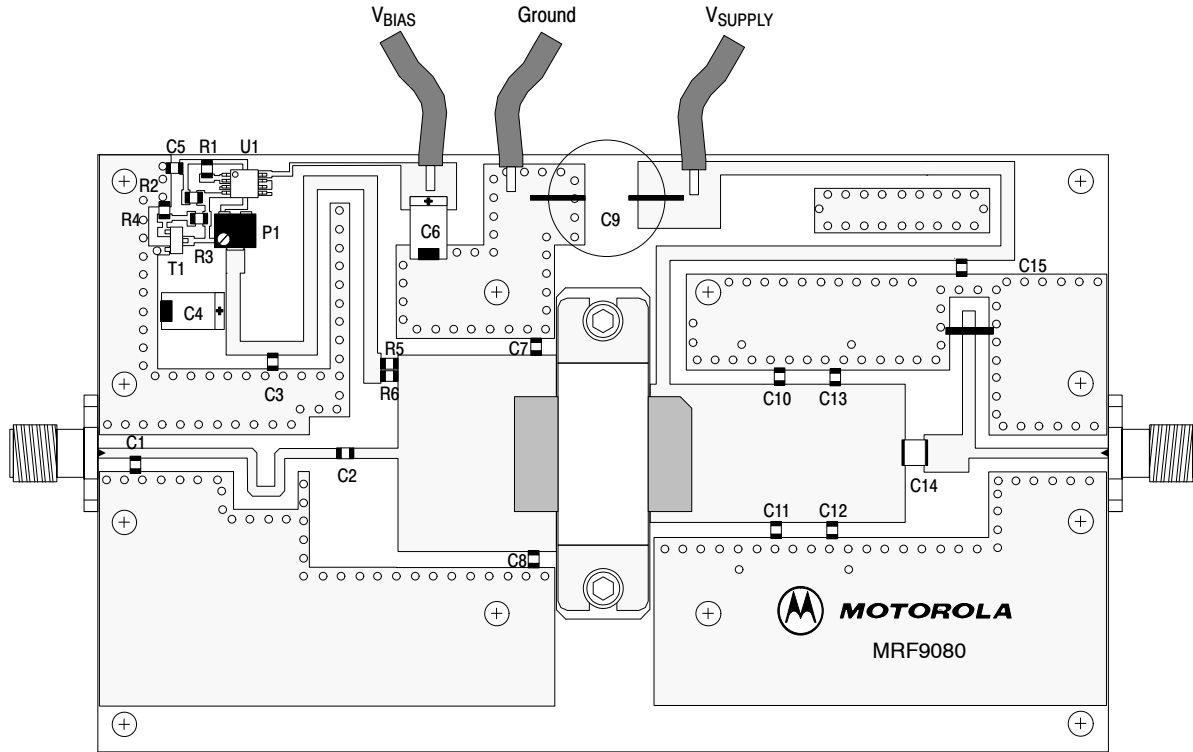

Figure 3. Broadband GSM 900 Optimized Demo Board Schematic

Table 6. Broadband GSM 900 Optimized Demo Board Component Designations and Values

Part	Description	Part Number	Manufacturer
C1	4.7 pF Chip Capacitor, ACCU-P	08051J4R7CBS	AVX
C2	3.9 pF Chip Capacitor, ACCU-P	08051J3R9CBS	AVX
C3, C15	22 pF Chip Capacitors, ACCU-P	08051J221CBS	AVX
C4, C6	22 $\mu$ F, 35 V Tantalum Chip Capacitors	T491X226K035AS	Kemet
C5	1 $\mu$ F Chip Capacitor, ACCU-P	08053105	AVX
C7, C8	5.6 pF Chip Capacitors, ACCU-P	08051J5R6CBS	AVX
C9	220 $\mu$ F, 63 V Electrolytic Capacitor	2222-136-68221	Vishay
C10, C11	3.3 pF Chip Capacitors, ACCU-P	08051J3R3CBS	AVX
C12, C13	2.2 pF Chip Capacitors, ACCU-P	08051J2R2CBS	AVX
C14	4.7 pF Chip Capacitor	ATC100B4R7JT500XT	ATC
P1	5.0 k $\Omega$ Potentiometer CMS Cermet Multi-turn	3224W	Bourns
R1	10 $\Omega$ , 1/8 W Chip Resistor	CRCW080510R0FKEA	Vishay
R2, R5, R6	1 k $\Omega$ , 1/8 W Chip Resistor	CRCW08051001FKEA	Vishay
R3	1.2 k $\Omega$ , 1/8 W Chip Resistor	CRCW08051201FKEA	Vishay
R4	2.2 k $\Omega$ , 1/8 W Chip Resistor	CRCW08052201FKEA	Vishay
T1	Bipolar NPN Transistor, SOT-23	BC847ALT1G	ON Semiconductor
U1	Voltage Regulator, Micro-8	LP2951ACDMR2G	ON Semiconductor
	Substrate = Taconic RF35, Thickness 0.5 mm		



Freescall has begun the transition of marking Printed Circuit Boards (PCBs) with the Freescall Semiconductor signature/logo. PCBs may have either Motorola or Freescall markings during the transition period. These changes will have no impact on form, fit or function of the current product.

**Figure 4. Broadband GSM 900 Optimized Demo Board Component Layout**

**TYPICAL CHARACTERISTICS  
(IN FREESCALE BROADBAND GSM 900 OPTIMIZED DEMO BOARD)**

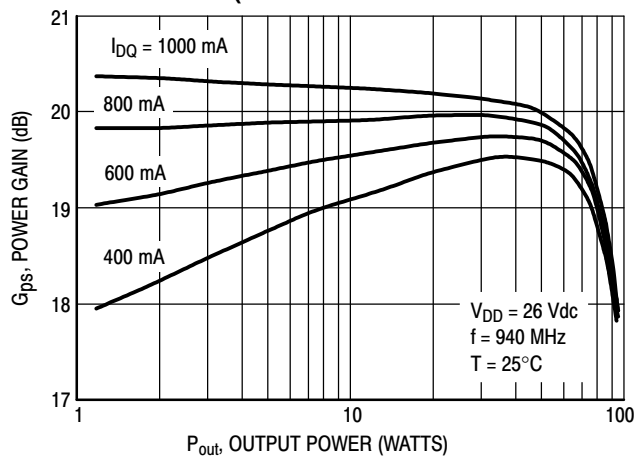

**Figure 5. Power Gain versus Output Power**

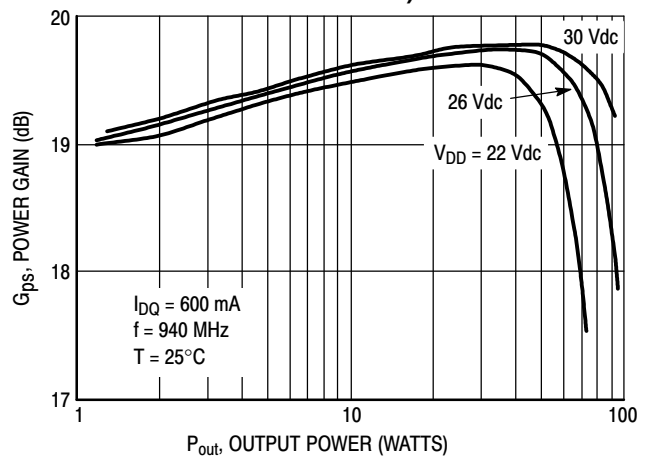

**Figure 6. Power Gain versus Output Power**

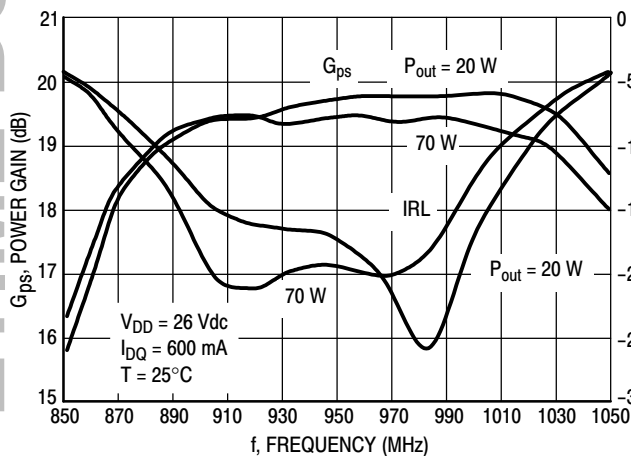

**Figure 7. Power Gain and Input Return Loss versus Frequency**

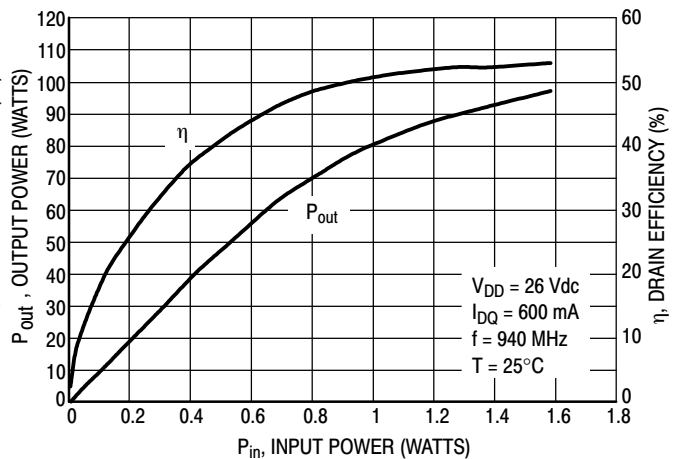

**Figure 8. Output Power and Efficiency versus Input Power**

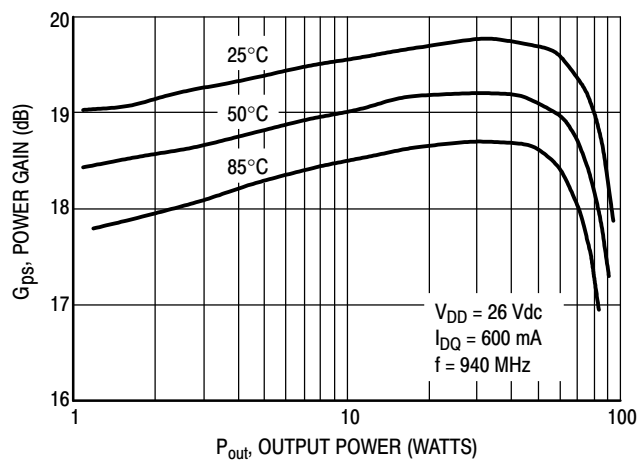

**Figure 9. Power Gain versus Output Power**

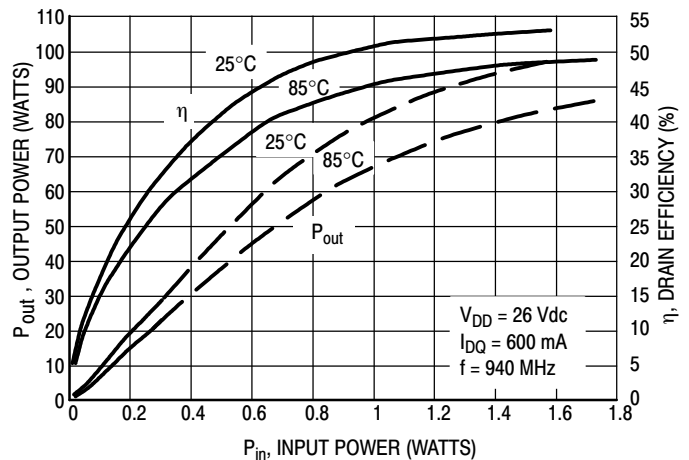

**Figure 10. Output Power and Efficiency versus Input Power**

LIFETIME BUY

LAST ORDER 3 OCT 08 LAST SHIP 14 MAY 09

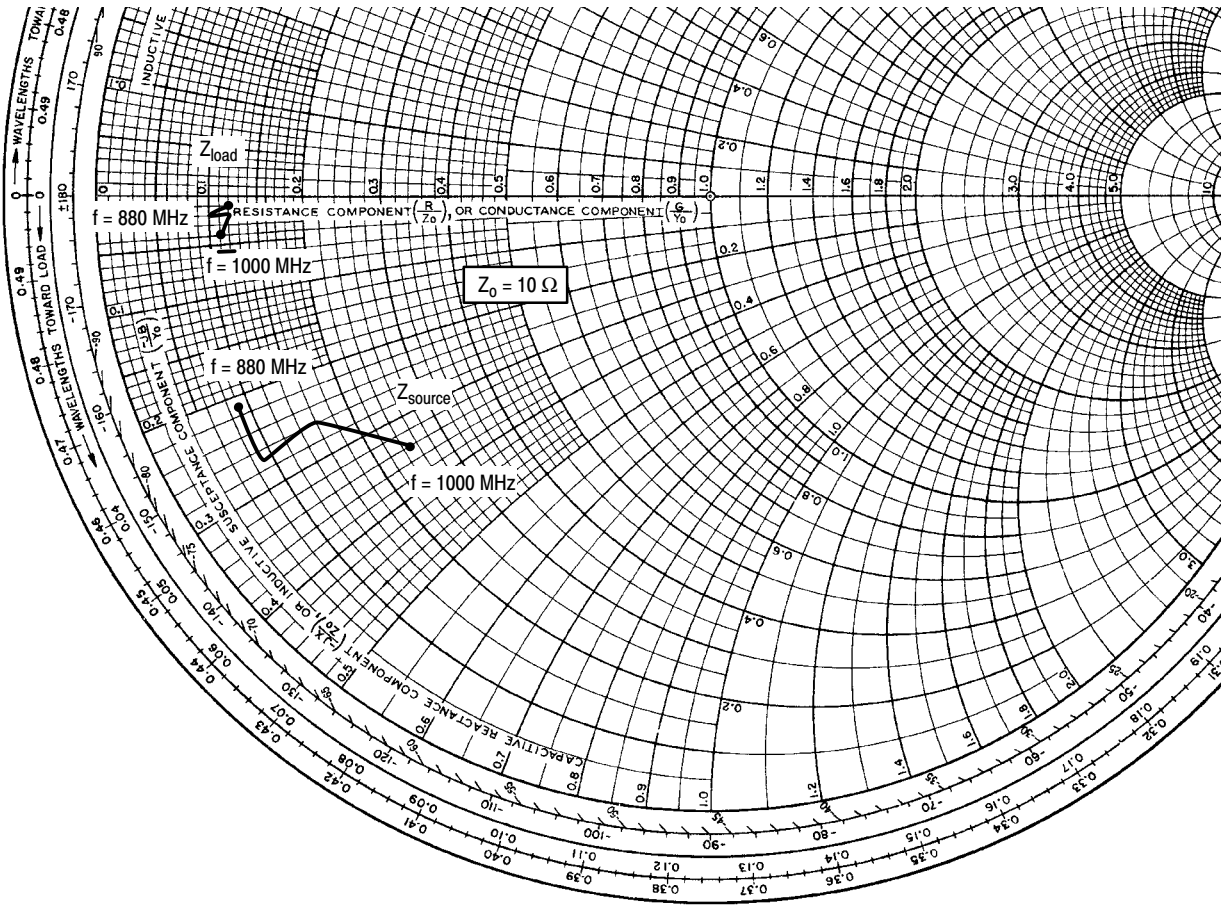

$V_{DD} = 26\text{ V}$ ,  $I_{DQ} = 600\text{ mA}$ ,  $P_{out} = 90\text{ W CW}$

f MHz	$Z_{source}$ $\Omega$	$Z_{load}$ $\Omega$
880	$0.91 - j2.11$	$1.22 - j0.12$
920	$0.88 - j2.65$	$1.00 - j0.16$
960	$1.6 - j2.61$	$1.22 - j0.22$
1000	$2.45 - j3.38$	$1.14 - j0.41$

$Z_{source}$  = Test circuit impedance as measured from gate to ground.

$Z_{load}$  = Test circuit impedance as measured from drain to ground.

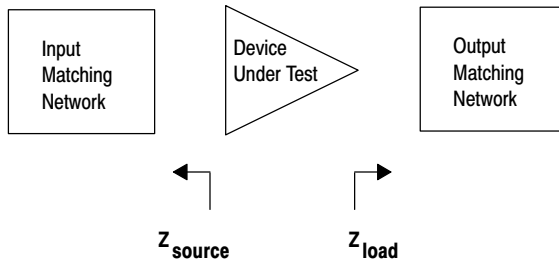
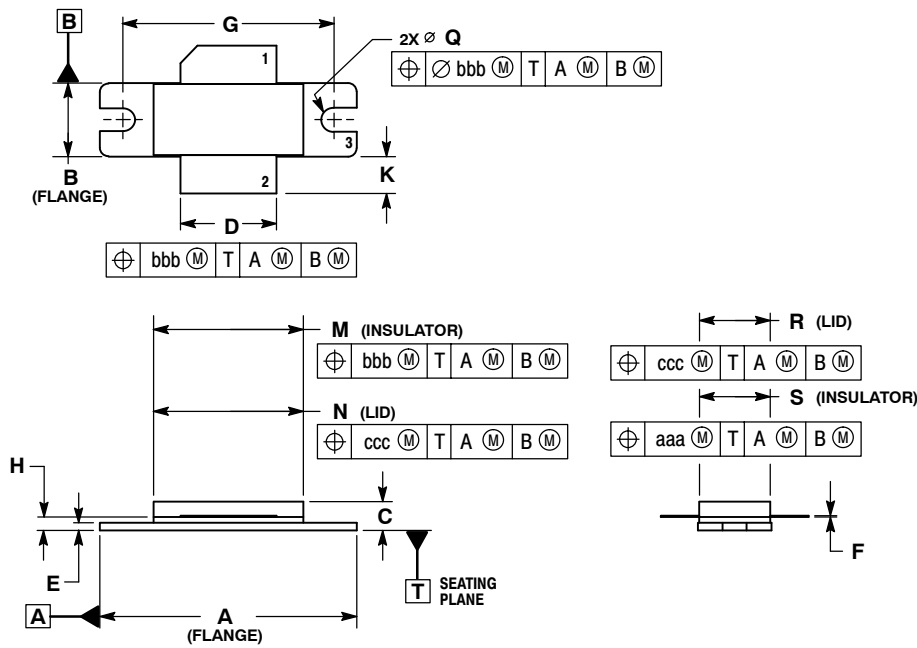

Figure 11. Series Equivalent Source and Load Impedance

## PACKAGE DIMENSIONS



- NOTES:
1. DIMENSIONING AND TOLERANCING PER ANSI Y14.5M-1994.
  2. CONTROLLING DIMENSION: INCH.
  3. DELETED
  4. DIMENSION H IS MEASURED 0.030 (0.762) AWAY FROM PACKAGE BODY.

DIM	INCHES		MILLIMETERS	
	MIN	MAX	MIN	MAX
A	1.335	1.345	33.91	34.16
B	0.380	0.390	9.65	9.91
C	0.125	0.170	3.18	4.32
D	0.495	0.505	12.57	12.83
E	0.035	0.045	0.89	1.14
F	0.003	0.006	0.08	0.15
G	1.100 BSC		27.94 BSC	
H	0.057	0.067	1.45	1.70
K	0.170	0.210	4.32	5.33
M	0.774	0.786	19.66	19.96
N	0.772	0.788	19.60	20.00
Q	Ø 1.118	Ø 1.138	Ø 3.00	Ø 3.51
R	0.365	0.375	9.27	9.53
S	0.365	0.375	9.27	9.52
aaa	0.005 REF		0.127 REF	
bbb	0.010 REF		0.254 REF	
ccc	0.015 REF		0.381 REF	

- STYLE 1:  
 PIN 1. DRAIN  
 2. GATE  
 3. SOURCE

**CASE 465-06  
 ISSUE G  
 NI-780  
 MRF9080LR3**

## PRODUCT DOCUMENTATION

Refer to the following documents to aid your design process.

### Engineering Bulletins

- EB212: Using Data Sheet Impedances for RF LDMOS Devices

## REVISION HISTORY

The following table summarizes revisions to this document.

Revision	Date	Description
8	Oct. 2008	<ul style="list-style-type: none"><li>• Data sheet revised to reflect part status change, p. 1, including use of applicable overlay.</li><li>• Modified data sheet to reflect RF Test Reduction described in Product and Process Change Notification number, PCN12779, p. 1, 2</li><li>• Updated Part Numbers in Tables 5 and 6, Component Designations and Values, to RoHS compliant part numbers, p. 3, 5</li><li>• Added Product Documentation and Revision History, p. 10</li></ul>

## **How to Reach Us:**

### **Home Page:**

[www.freescale.com](http://www.freescale.com)

### **Web Support:**

<http://www.freescale.com/support>

### **USA/Europe or Locations Not Listed:**

Freescale Semiconductor, Inc.  
Technical Information Center, EL516  
2100 East Elliot Road  
Tempe, Arizona 85284  
1-800-521-6274 or +1-480-768-2130  
[www.freescale.com/support](http://www.freescale.com/support)

### **Europe, Middle East, and Africa:**

Freescale Halbleiter Deutschland GmbH  
Technical Information Center  
Schatzbogen 7  
81829 Muenchen, Germany  
+44 1296 380 456 (English)  
+46 8 52200080 (English)  
+49 89 92103 559 (German)  
+33 1 69 35 48 48 (French)  
[www.freescale.com/support](http://www.freescale.com/support)

### **Japan:**

Freescale Semiconductor Japan Ltd.  
Headquarters  
ARCO Tower 15F  
1-8-1, Shimo-Meguro, Meguro-ku,  
Tokyo 153-0064  
Japan  
0120 191014 or +81 3 5437 9125  
[support.japan@freescale.com](mailto:support.japan@freescale.com)

### **Asia/Pacific:**

Freescale Semiconductor China Ltd.  
Exchange Building 23F  
No. 118 Jianguo Road  
Chaoyang District  
Beijing 100022  
China  
+86 10 5879 8000  
[support.asia@freescale.com](mailto:support.asia@freescale.com)

### **For Literature Requests Only:**

Freescale Semiconductor Literature Distribution Center  
P.O. Box 5405  
Denver, Colorado 80217  
1-800-441-2447 or +1-303-675-2140  
Fax: +1-303-675-2150  
[LDCForFreescaleSemiconductor@hibbertgroup.com](mailto:LDCForFreescaleSemiconductor@hibbertgroup.com)

Information in this document is provided solely to enable system and software implementers to use Freescale Semiconductor products. There are no express or implied copyright licenses granted hereunder to design or fabricate any integrated circuits or integrated circuits based on the information in this document.

Freescale Semiconductor reserves the right to make changes without further notice to any products herein. Freescale Semiconductor makes no warranty, representation or guarantee regarding the suitability of its products for any particular purpose, nor does Freescale Semiconductor assume any liability arising out of the application or use of any product or circuit, and specifically disclaims any and all liability, including without limitation consequential or incidental damages. "Typical" parameters that may be provided in Freescale Semiconductor data sheets and/or specifications can and do vary in different applications and actual performance may vary over time. All operating parameters, including "Typicals", must be validated for each customer application by customer's technical experts. Freescale Semiconductor does not convey any license under its patent rights nor the rights of others. Freescale Semiconductor products are not designed, intended, or authorized for use as components in systems intended for surgical implant into the body, or other applications intended to support or sustain life, or for any other application in which the failure of the Freescale Semiconductor product could create a situation where personal injury or death may occur. Should Buyer purchase or use Freescale Semiconductor products for any such unintended or unauthorized application, Buyer shall indemnify and hold Freescale Semiconductor and its officers, employees, subsidiaries, affiliates, and distributors harmless against all claims, costs, damages, and expenses, and reasonable attorney fees arising out of, directly or indirectly, any claim of personal injury or death associated with such unintended or unauthorized use, even if such claim alleges that Freescale Semiconductor was negligent regarding the design or manufacture of the part.

Freescale™ and the Freescale logo are trademarks of Freescale Semiconductor, Inc. All other product or service names are the property of their respective owners.

© Freescale Semiconductor, Inc. 2008. All rights reserved.

