

The RF MOSFET Line
RF Power Field Effect Transistor
N-Channel Enhancement-Mode Lateral MOSFET

Designed for broadband commercial and industrial applications at frequencies up to 1.0 GHz and specified for the GSM 925 – 960 MHz band. The high gain and broadband performance of these devices makes them ideal for large-signal, common source amplifier applications in 28 volt base station equipment.

- Specified Performance @ 960 MHz, 28 Volts
 - Output Power — 60 Watts
 - Power Gain — 12.5 dB (Min)
 - Efficiency — 53% (Min)
- 100% Tested for Load Mismatch Stress at all Phase Angles with 5:1 VSWR

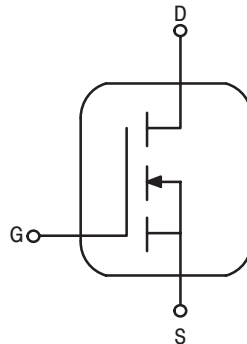

MRF6522-60

**960 MHz, 60 W
LATERAL N-CHANNEL
BROADBAND
RF POWER MOSFET**

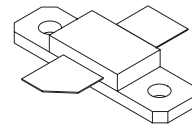

CASE 360B-04, STYLE 1

MAXIMUM RATINGS

Rating	Symbol	Value	Unit
Drain-Source Voltage	V_{DSS}	60	Vdc
Gate-Source Voltage	V_{GS}	± 20	Vdc
Drain Current — Continuous	I_D	7	Adc
Total Device Dissipation @ $T_C > = 25^\circ\text{C}$ Derate above 25°C	P_D	118 0.9	Watts W/ $^\circ\text{C}$
Storage Temperature Range	T_{stg}	-65 to +150	$^\circ\text{C}$
Operating Junction Temperature	T_J	200	$^\circ\text{C}$

THERMAL CHARACTERISTICS

Characteristic	Symbol	Max	Unit
Thermal Resistance, Junction to Case	$R_{\theta JC}$	1.1	$^\circ\text{C/W}$

NOTE – **CAUTION** – MOS devices are susceptible to damage from electrostatic charge. Reasonable precautions in handling and packaging MOS devices should be observed.

ELECTRICAL CHARACTERISTICS ($T_C = 25^\circ\text{C}$ unless otherwise noted)

Characteristic	Symbol	Min	Typ	Max	Unit
----------------	--------	-----	-----	-----	------

OFF CHARACTERISTICS

Drain–Source Breakdown Voltage ($V_{GS} = 0\text{ Vdc}$, $I_D = 1\ \mu\text{Adc}$)	$V_{(BR)DSS}$	60	—	—	Vdc
Zero Gate Voltage Drain Current ($V_{DS} = 28\text{ Vdc}$, $V_{GS} = 0$)	I_{DSS}	—	—	1	μAdc
Gate–Source Leakage Current ($V_{GS} = 20\text{ Vdc}$, $V_{DS} = 0$)	I_{GSS}	—	—	1	μAdc

ON CHARACTERISTICS

Gate Threshold Voltage ($V_{DS} = 10\text{ Vdc}$, $I_D = 200\ \mu\text{Adc}$)	$V_{GS(th)}$	2	3	4	Vdc
Gate Quiescent Voltage ($V_{DS} = 28\text{ Vdc}$, $I_D = 400\ \text{mAdc}$)	$V_{GS(Q)}$	3	4	5	Vdc
Drain–Source On–Voltage ($V_{GS} = 10\text{ Vdc}$, $I_D = 3\ \text{Adc}$)	$V_{DS(on)}$	—	0.65	0.8	Vdc
Forward Transconductance ($V_{DS} = 10\text{ Vdc}$, $I_D = 3\ \text{Adc}$)	g_{fs}	2.2	2.6	—	S

DYNAMIC CHARACTERISTICS

Input Capacitance (Includes Internal Input MOScap) ($V_{DS} = 26\text{ Vdc}$, $V_{GS} = 0$, $f = 1\ \text{MHz}$)	C_{iss}	—	83	—	pF
Output Capacitance ($V_{DS} = 26\text{ Vdc}$, $V_{GS} = 0$, $f = 1\ \text{MHz}$)	C_{oss}	—	44	—	pF
Reverse Transfer Capacitance ($V_{DS} = 26\text{ Vdc}$, $V_{GS} = 0$, $f = 1\ \text{MHz}$)	C_{rss}	—	4.3	—	pF

FUNCTIONAL TESTS (In Motorola Test Fixture)

Common–Source Amplifier Power Gain ($V_{DD} = 28\text{ Vdc}$, $P_{out} = 60\ \text{W}$, $I_{DQ} = 400\ \text{mA}$, $f = 960\ \text{MHz}$)	G_{ps}	12.5	—	—	dB
Drain Efficiency ($V_{DD} = 28\text{ Vdc}$, $P_{out} = 60\ \text{W}$, $I_{DQ} = 400\ \text{mA}$, $f = 960\ \text{MHz}$)	η	53	—	—	%
Output Mismatch Stress ($V_{DD} = 28\text{ Vdc}$, $P_{out} = 60\ \text{W}$, $I_{DQ} = 400\ \text{mA}$, $f = 960\ \text{MHz}$, $VSWR = 5:1$, All Phase Angles)	Ψ	No Degradation In Output Power Before and After Test			

ARCHIVED 2005

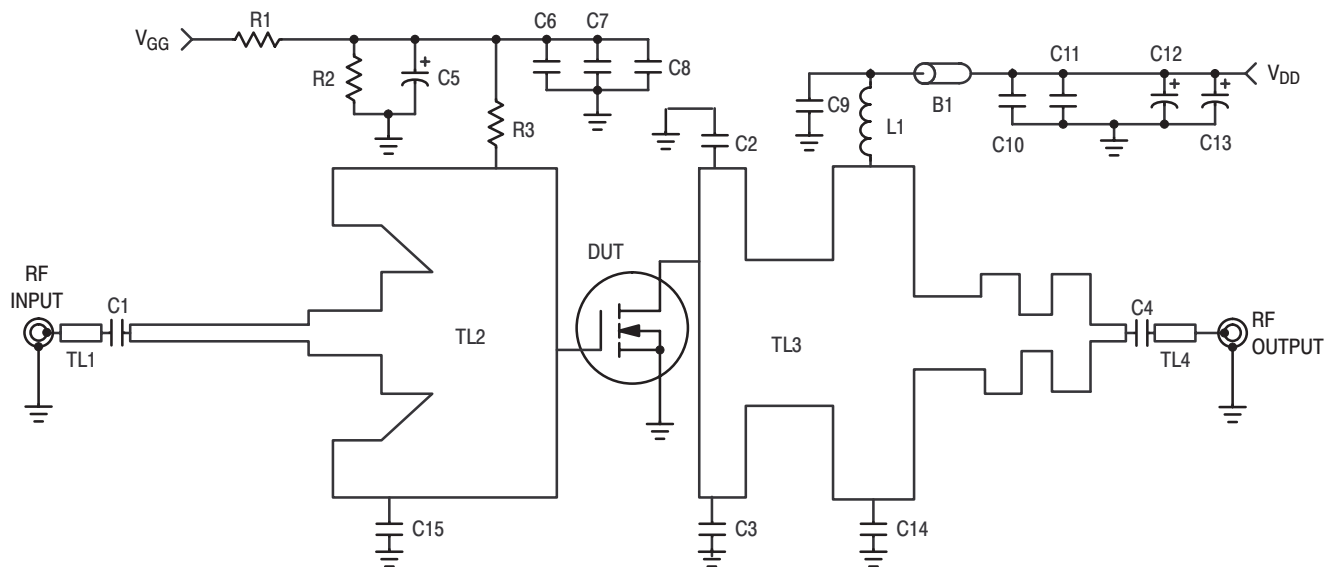

B1	Short RF Bead Fair Rite-2743019447	C15	1.2 pF, Chip Capacitor
C1	15 pF Chip Capacitor	L1	5 Turns, 20 AWG, IDIA 0.126"
C2, C3, C6, C9	47 pF Chip Capacitor	R1	10 k Ω , 1/4 W Resistor
C4	100 pF Chip Capacitor	R2	13 k Ω , 1/4 W Resistor
C5, C12	10 μ F, 50 Vdc Electrolytic Capacitor	R3	1.0 k Ω , 1/4 W Chip Resistor
C7, C10	1000 pF Chip Capacitor	TL1-TL4	Microstrip Line
C8, C11	0.1 μ F, 50 Vdc Chip Capacitor	Ckt Board	1/32" Glass Teflon [®] , $\epsilon_r = 2.55$
C13	470 μ F, 50 Vdc Electrolytic Capacitor		ARLON-GX-0300-55-22
C14	0.2 pF, Chip Capacitor		

Figure 1. MRF6522-60 Test Circuit Schematic

TYPICAL CHARACTERISTICS

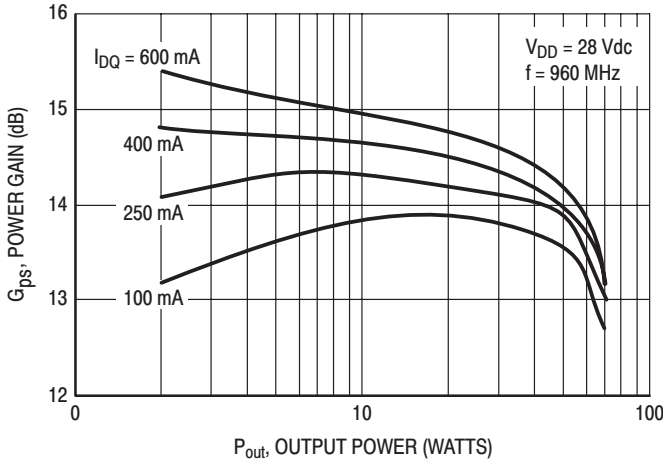

Figure 2. Power Gain versus Output Power

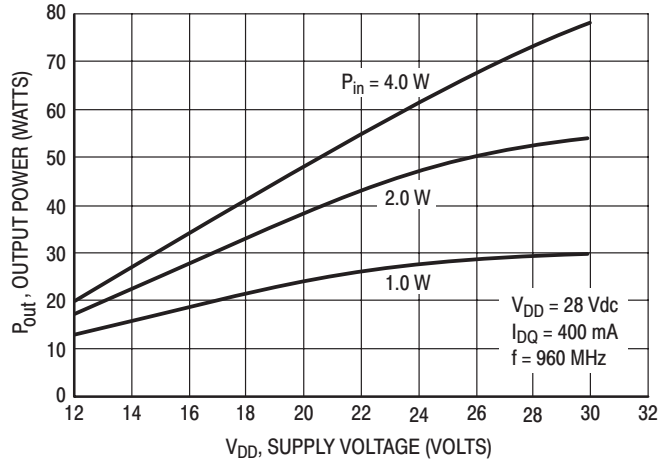

Figure 3. Output Power versus Supply Voltage

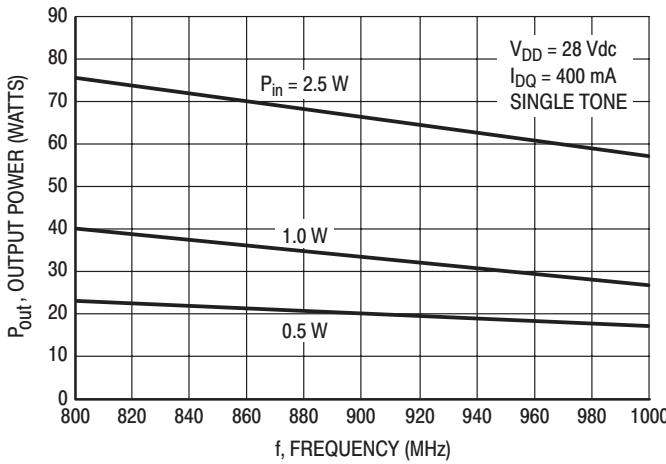

Figure 4. Output Power versus Frequency

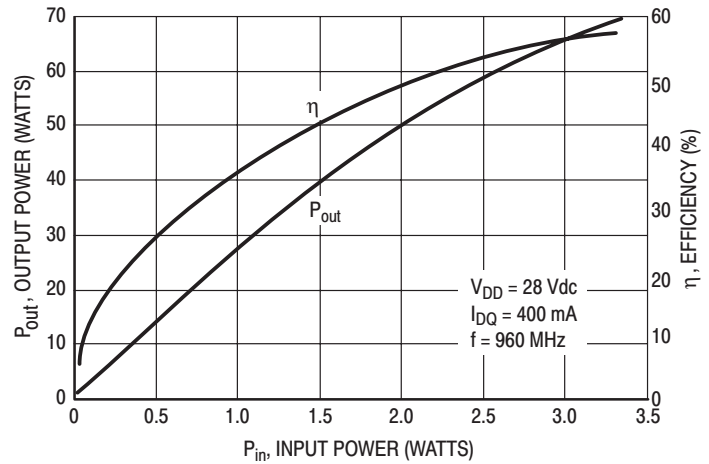

Figure 5. Output Power versus Input Power

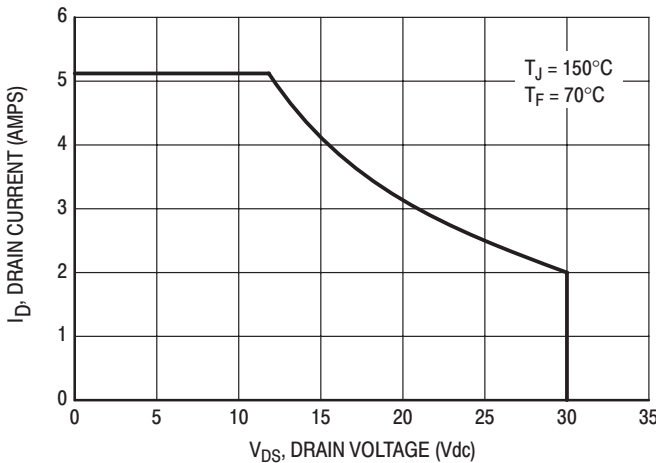

Figure 6. DC Safe Operating Area

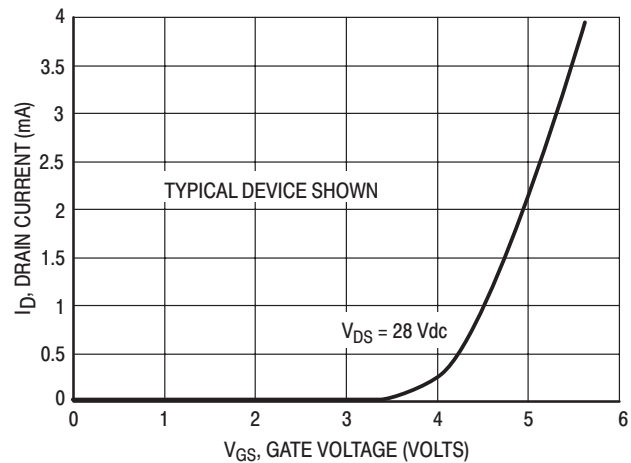

Figure 7. Drain Current versus Gate Voltage

ARCHIVED 2005

TYPICAL CHARACTERISTICS

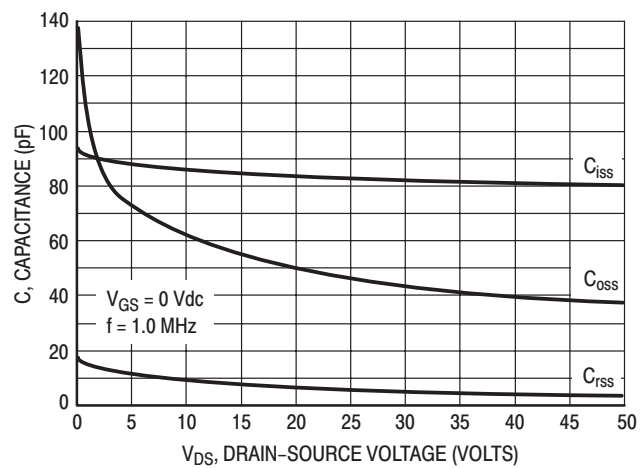
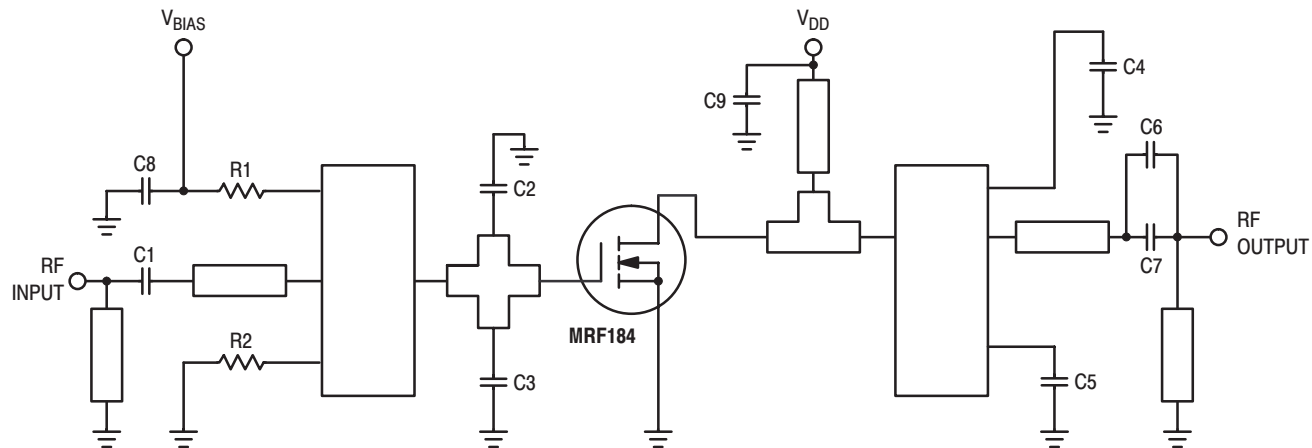

Figure 8. Capacitance versus Voltage

ARCHIVED 2005

BROADBAND CIRCUIT APPLICATION
 (As Shown in Application Note AN1670/D, "60 Watts, GSM 900 MHz, LDMOS Two-Stage Amplifier")



C1	5.6 pF (AVX ACCUP)	C7	2.2 pF (AVX ACCUP)
C2, C3	15 pF (AVX ACCUP)	C8, C9	470 pF (NPO)
C4, C5	10 pF (AVX ACCUP)	R1	3.9 kΩ
C6	2.7 pF (AVX ACCUP)	R2	1 kΩ

Figure 9. GSM 900 Amplifier Schematic

ARCHIVED 2005

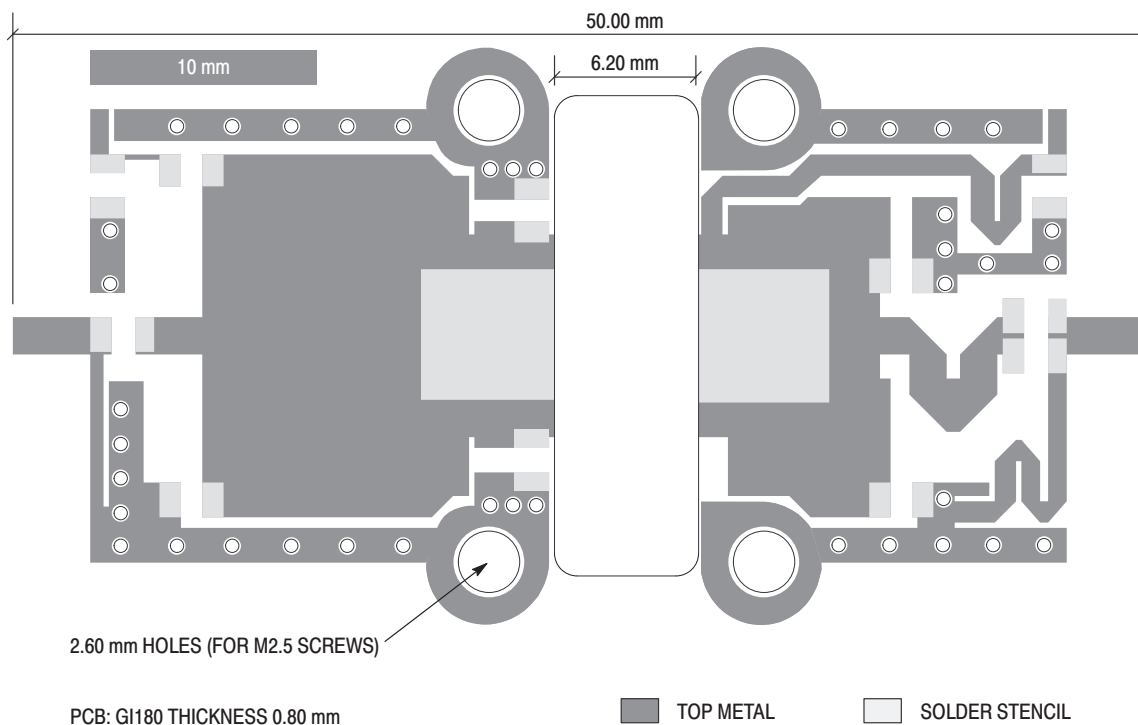

Figure 10. PCB Layout

BROADBAND CIRCUIT APPLICATION
 (As Shown in Application Note AN1670/D, "60 Watts, GSM 900 MHz, LDMOS Two-Stage Amplifier")

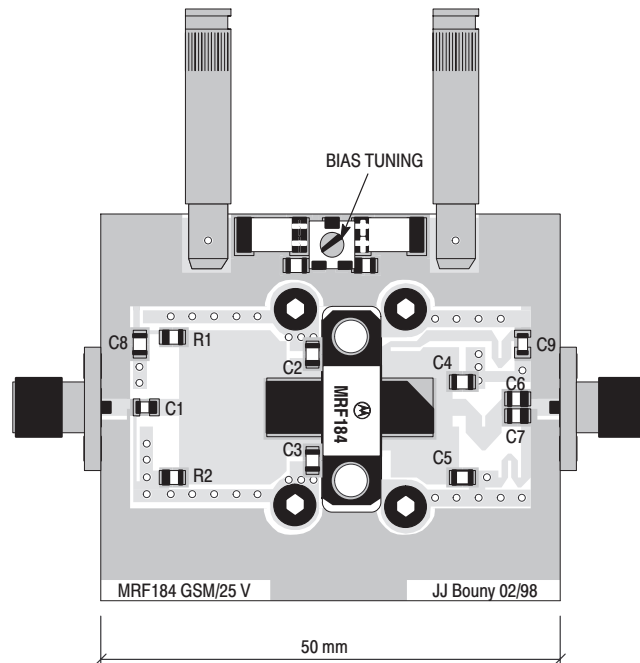

Figure 11. Component Parts Layout

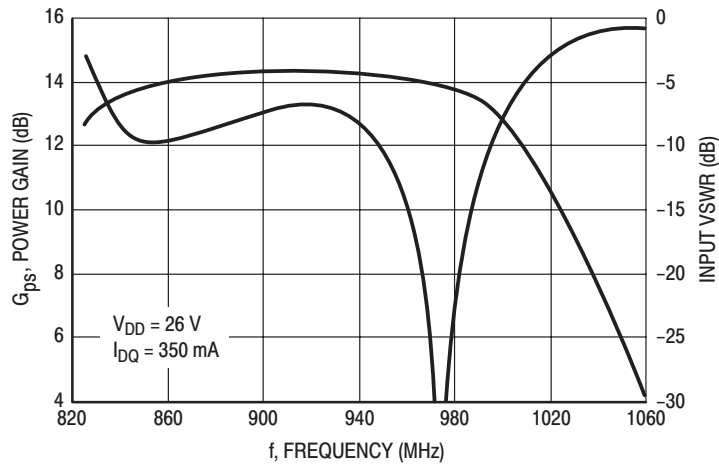
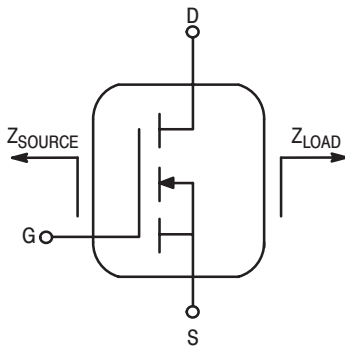
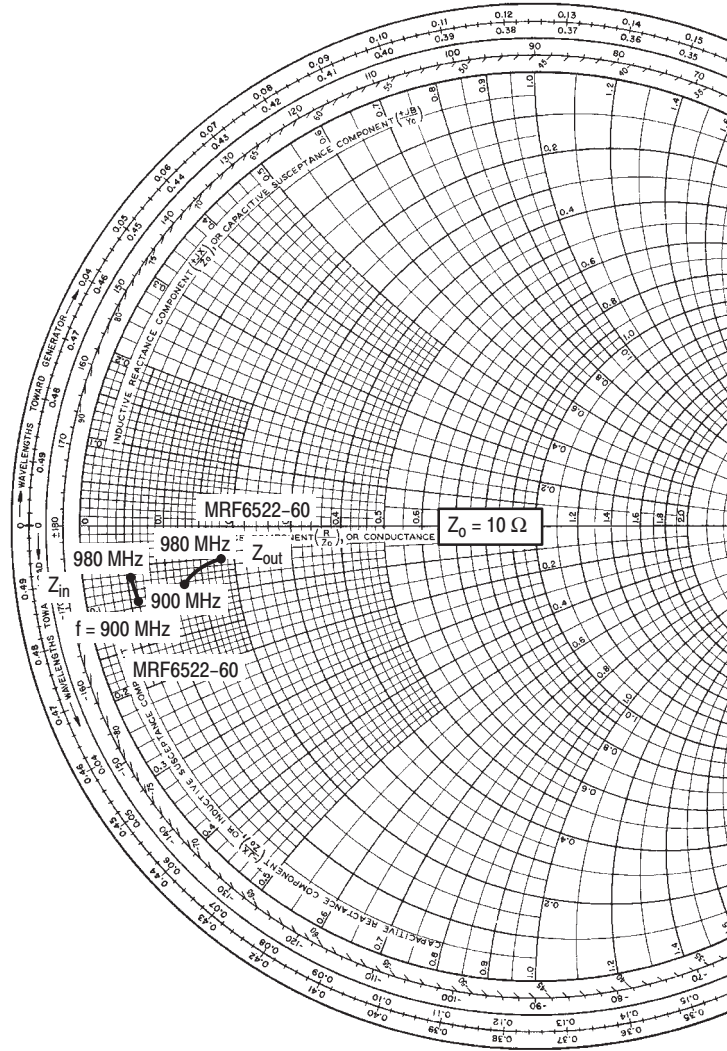

Figure 12. Performance in Broadband Circuit (at Small Signal)

ARCHIVED 2005



26 V, 70 Watts

f MHz	S ₁₁	S ₂₂	Z _{in} Ohms	Z _{out} Ohms
900	0.66 + j4.71	2.41 + j2.91	0.60 - j0.93	1.48 - j0.82
920	0.64 + j4.79	2.32 + j2.94	0.59 - j0.88	1.50 - j0.77
940	0.61 + j4.89	2.26 + j3.02	0.57 - j0.82	1.62 - j0.71
960	0.58 + j4.97	2.23 + j3.05	0.56 - j0.73	1.79 - j0.60
980	0.59 + j5.03	2.22 + j3.27	0.55 - j0.66	1.82 - j0.49

Z_{in} = Conjugate of source impedance.

Z_{out} = Conjugate of the load impedance at a given output power, voltage, frequency and efficiency.

Figure 13. Input and Output Impedances

NOTES

ARCHIVED 2005

NOTES

ARCHIVED 2005

MRF6522-60
10

MOTOROLA RF DEVICE DATA

Archived 2005

PACKAGE DIMENSIONS

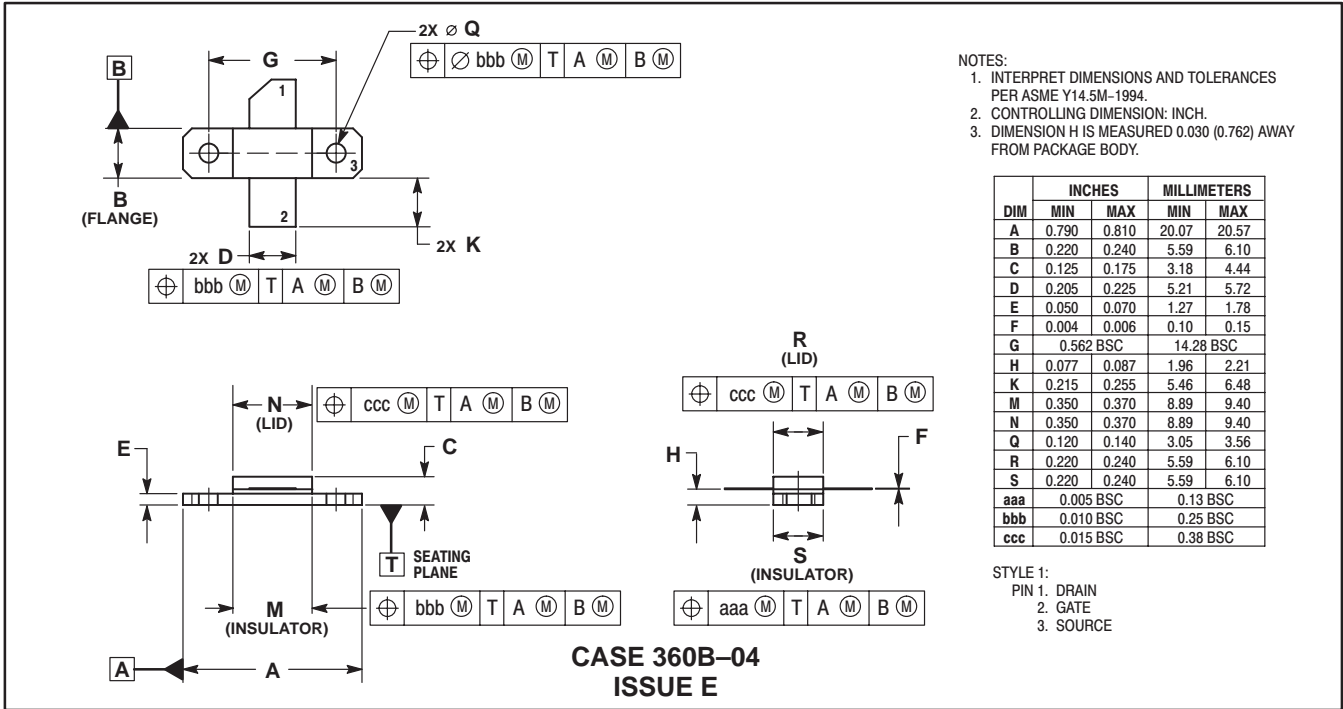

ARCHIVED 2005

Motorola reserves the right to make changes without further notice to any products herein. Motorola makes no warranty, representation or guarantee regarding the suitability of its products for any particular purpose, nor does Motorola assume any liability arising out of the application or use of any product or circuit, and specifically disclaims any and all liability, including without limitation consequential or incidental damages. "Typical" parameters which may be provided in Motorola data sheets and/or specifications can and do vary in different applications and actual performance may vary over time. All operating parameters, including "Typicals" must be validated for each customer application by customer's technical experts. Motorola does not convey any license under its patent rights nor the rights of others. Motorola products are not designed, intended, or authorized for use as components in systems intended for surgical implant into the body, or other applications intended to support or sustain life, or for any other application in which the failure of the Motorola product could create a situation where personal injury or death may occur. Should Buyer purchase or use Motorola products for any such unintended or unauthorized application, Buyer shall indemnify and hold Motorola and its officers, employees, subsidiaries, affiliates, and distributors harmless against all claims, costs, damages, and expenses, and reasonable attorney fees arising out of, directly or indirectly, any claim of personal injury or death associated with such unintended or unauthorized use, even if such claim alleges that Motorola was negligent regarding the design or manufacture of the part. Motorola and  are registered trademarks of Motorola, Inc. Motorola, Inc. is an Equal Opportunity/Affirmative Action Employer.

How to reach us:

USA/EUROPE/Locations Not Listed: Motorola Literature Distribution; P.O. Box 5405, Denver, Colorado 80217. 1-303-675-2140 or 1-800-441-2447

JAPAN: Motorola Japan Ltd.; SPS, Technical Information Center, 3-20-1, Minami-Azabu. Minato-ku, Tokyo 106-8573 Japan. 81-3-3440-3569

ASIA/PACIFIC: Motorola Semiconductors H.K. Ltd.; Silicon Harbour Centre, 2 Dai King Street, Tai Po Industrial Estate, Tai Po, N.T., Hong Kong. 852-2668334

Technical Information Center: 1-800-521-6274

HOME PAGE: <http://www.motorola.com/semiconductors/>



MOTOROLA

MRF6522-60/D