

MRF5S19130R3 and MRF5S19130SR3 replaced by MRF5S19130HR3 and MRF5S19130HSR3. "H" suffix indicates lower thermal resistance package.

**The RF MOSFET Line**  
**RF Power Field Effect Transistors**  
**N-Channel Enhancement-Mode Lateral MOSFETs**

Designed for PCN and PCS base station applications at frequencies from 1.9 to 2.0 GHz. Suitable for TDMA, CDMA and multicarrier amplifier applications.

- Typical 2-Carrier N-CDMA Performance for  $V_{DD} = 28$  Volts,  $I_{DQ} = 1200$  mA,  $f_1 = 1958.75$  MHz,  $f_2 = 1961.25$  MHz IS-95 CDMA (Pilot, Sync, Paging, Traffic Codes 8 Through 13) 1.2288 MHz Channel Bandwidth Carrier. Adjacent Channels Measured over a 30 kHz Bandwidth at  $f_1 - 885$  kHz and  $f_2 + 885$  kHz. Distortion Products Measured over 1.2288 MHz Bandwidth at  $f_1 - 2.5$  MHz and  $f_2 + 2.5$  MHz. Peak/Avg. = 9.8 dB @ 0.01% Probability on CCDF.  
 Output Power — 26 Watts Avg.  
 Power Gain — 13 dB  
 Efficiency — 25%  
 IM3 — -37 dBc  
 ACPR — -51 dB
- Internally Matched, Controlled Q, for Ease of Use
- High Gain, High Efficiency and High Linearity
- Integrated ESD Protection
- Designed for Maximum Gain and Insertion Phase Flatness
- Capable of Handling 10:1 VSWR, @ 28 Vdc,  $f_1 = 1960$  MHz, 110 Watts CW Output Power
- Excellent Thermal Stability
- Characterized with Series Equivalent Large-Signal Impedance Parameters
- Qualified Up to a Maximum of 32 V Operation
- Available in Tape and Reel. R3 Suffix = 250 Units per 56 mm, 13 inch Reel.

**MRF5S19130R3**  
**MRF5S19130SR3**

**1990 MHz, 26 W AVG.,**  
**2 x N-CDMA, 28 V**  
**LATERAL N-CHANNEL**  
**RF POWER MOSFETs**

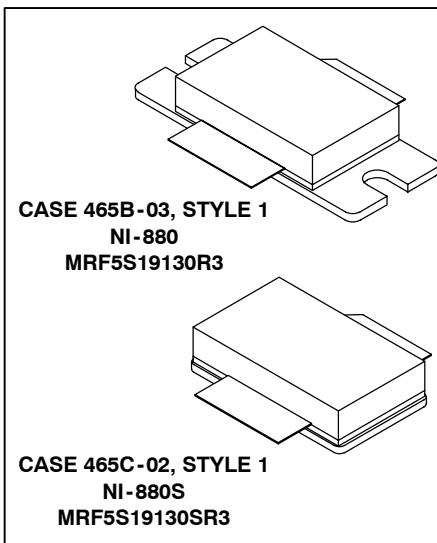

Freescale Semiconductor, Inc. ARCHIVE INFORMATION

ARCHIVE INFORMATION

**MAXIMUM RATINGS**

Rating	Symbol	Value	Unit
Drain-Source Voltage	$V_{DSS}$	65	Vdc
Gate-Source Voltage	$V_{GS}$	-0.5, +15	Vdc
Total Device Dissipation @ $T_C = 25^\circ\text{C}$ Derate above $25^\circ\text{C}$	$P_D$	324 1.85	Watts W/ $^\circ\text{C}$
Storage Temperature Range	$T_{stg}$	-65 to +150	$^\circ\text{C}$
Operating Junction Temperature	$T_J$	200	$^\circ\text{C}$
CW Operation	CW	110	Watts

**THERMAL CHARACTERISTICS**

Characteristic	Symbol	Max	Unit
Thermal Resistance, Junction to Case Case Temperature $80^\circ\text{C}$ , 110 W CW Case Temperature $80^\circ\text{C}$ , 26 W CW	$R_{\theta JC}$	0.54 0.60	$^\circ\text{C}/\text{W}$

NOTE - **CAUTION** - MOS devices are susceptible to damage from electrostatic charge. Reasonable precautions in handling and packaging MOS devices should be observed.

# Freescale Semiconductor, Inc.

## ESD PROTECTION CHARACTERISTICS

Test Conditions	Class
Human Body Model	2 (Minimum)
Machine Model	M4 (Minimum)
Charge Device Model	C7 (Minimum)

## ELECTRICAL CHARACTERISTICS (T<sub>C</sub> = 25°C unless otherwise noted)

Characteristic	Symbol	Min	Typ	Max	Unit
----------------	--------	-----	-----	-----	------

### OFF CHARACTERISTICS

Zero Gate Voltage Drain Leakage Current (V <sub>DS</sub> = 65 Vdc, V <sub>GS</sub> = 0 Vdc)	I <sub>DSS</sub>	—	—	10	μA <sub>dc</sub>
Zero Gate Voltage Drain Leakage Current (V <sub>DS</sub> = 28 Vdc, V <sub>GS</sub> = 0 Vdc)	I <sub>DSS</sub>	—	—	1	μA <sub>dc</sub>
Gate-Source Leakage Current (V <sub>GS</sub> = 5 Vdc, V <sub>DS</sub> = 0 Vdc)	I <sub>GSS</sub>	—	—	1	μA <sub>dc</sub>

### ON CHARACTERISTICS

Gate Threshold Voltage (V <sub>DS</sub> = 10 Vdc, I <sub>D</sub> = 200 μA <sub>dc</sub> )	V <sub>GS(th)</sub>	2.5	2.8	3.5	Vdc
Gate Quiescent Voltage (V <sub>DS</sub> = 28 Vdc, I <sub>D</sub> = 1200 mA <sub>dc</sub> )	V <sub>GS(Q)</sub>	—	3.8	—	Vdc
Drain-Source On-Voltage (V <sub>GS</sub> = 10 Vdc, I <sub>D</sub> = 3 A <sub>dc</sub> )	V <sub>DS(on)</sub>	—	0.26	—	Vdc
Forward Transconductance (V <sub>DS</sub> = 10 Vdc, I <sub>D</sub> = 3 A <sub>dc</sub> )	g <sub>fs</sub>	—	7.5	—	S

### DYNAMIC CHARACTERISTICS

Reverse Transfer Capacitance (1) (V <sub>DS</sub> = 28 Vdc ± 30 mV(rms) <sub>ac</sub> @ 1 MHz, V <sub>GS</sub> = 0 Vdc)	C <sub>r<sub>ss</sub></sub>	—	2.7	—	pF
--	-----------------------------	---	-----	---	----

### FUNCTIONAL TESTS (In Motorola Test Fixture, 50 ohm system) 2-Carrier N-CDMA, 1.2288 MHz Channel Bandwidth Carriers. Peak/Avg = 9.8 dB @ 0.01% Probability on CCDF.

Common-Source Amplifier Power Gain (V <sub>DD</sub> = 28 Vdc, P <sub>out</sub> = 26 W Avg, I <sub>DQ</sub> = 1200 mA, f <sub>1</sub> = 1930 MHz, f <sub>2</sub> = 1932.5 MHz and f <sub>1</sub> = 1987.5 MHz, f <sub>2</sub> = 1990 MHz)	G <sub>ps</sub>	12	13	—	dB
Drain Efficiency (V <sub>DD</sub> = 28 Vdc, P <sub>out</sub> = 26 W Avg, I <sub>DQ</sub> = 1200 mA, f <sub>1</sub> = 1930 MHz, f <sub>2</sub> = 1932.5 MHz and f <sub>1</sub> = 1987.5 MHz, f <sub>2</sub> = 1990 MHz)	η	23	25	—	%
Third Order Intermodulation Distortion (V <sub>DD</sub> = 28 Vdc, P <sub>out</sub> = 26 W Avg, I <sub>DQ</sub> = 1200 mA, f <sub>1</sub> = 1930 MHz, f <sub>2</sub> = 1932.5 MHz and f <sub>1</sub> = 1987.5 MHz, f <sub>2</sub> = 1990 MHz; IM3 measured over 1.2288 MHz Bandwidth at f <sub>1</sub> -2.5 MHz and f <sub>2</sub> +2.5 MHz referenced to carrier channel power.)	IM3	—	-37	-35	dBc
Adjacent Channel Power Ratio (V <sub>DD</sub> = 28 Vdc, P <sub>out</sub> = 26 W Avg, I <sub>DQ</sub> = 1200 mA, f <sub>1</sub> = 1930 MHz, f <sub>2</sub> = 1932.5 MHz and f <sub>1</sub> = 1987.5 MHz, f <sub>2</sub> = 1990 MHz; ACPR measured over 30 kHz Bandwidth at f <sub>1</sub> -885 kHz and f <sub>2</sub> +885 kHz)	ACPR	—	-51	-48	dBc
Input Return Loss (V <sub>DD</sub> = 28 Vdc, P <sub>out</sub> = 26 W Avg, I <sub>DQ</sub> = 1200 mA, f <sub>1</sub> = 1930 MHz, f <sub>2</sub> = 1932.5 MHz and f <sub>1</sub> = 1987.5 MHz, f <sub>2</sub> = 1990 MHz)	IRL	—	-15	-9	dB

(1) Part is internally matched both on input and output.

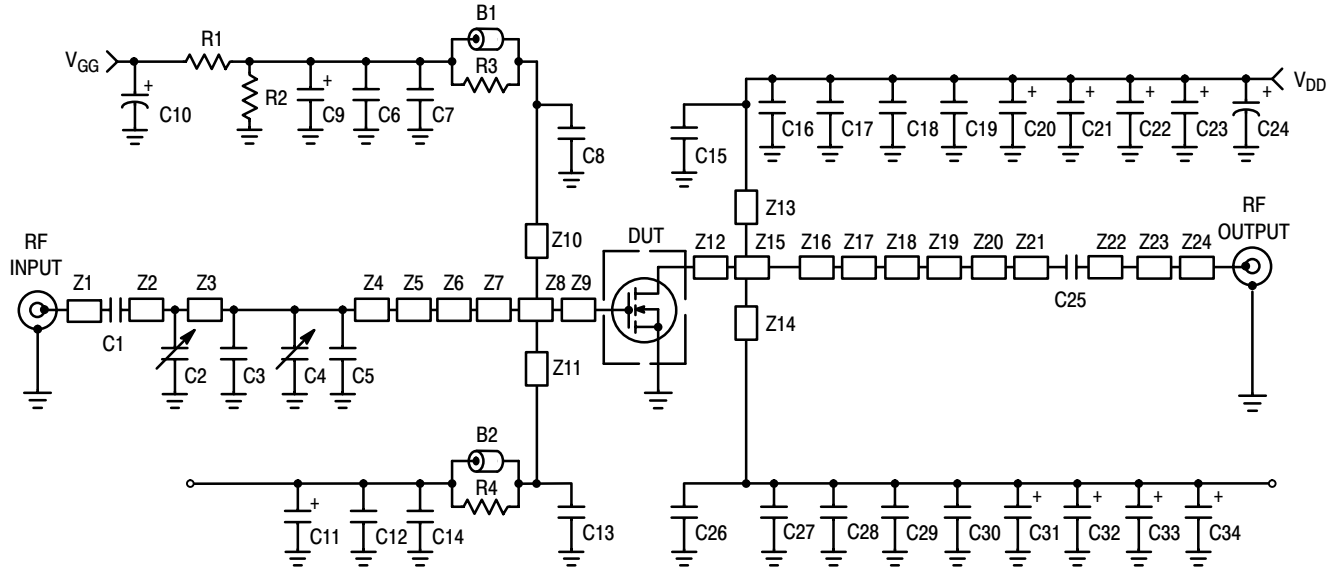

Z1	0.200" x 0.085" Microstrip	Z13, Z14	1.125" x 0.068" Microstrip
Z2	0.170" x 0.085" Microstrip	Z15	0.071" x 1.080" Microstrip
Z3	0.480" x 0.085" Microstrip	Z16	0.060" x 1.080" Microstrip
Z4	0.926" x 0.085" Microstrip	Z17	0.290" x 1.080" Microstrip
Z5	0.590" x 0.085" Microstrip	Z18	1.075" x 0.825" x 0.125" Taper
Z6	0.519" x 0.955" x 0.160" Taper	Z19	0.635" x 0.120" Microstrip
Z7	0.022" x 0.955" Microstrip	Z20	0.185" x 0.096" Microstrip
Z8	0.046" x 0.955" Microstrip	Z21	0.414" x 0.084" Microstrip
Z9	0.080" x 0.955" Microstrip	Z22	0.040" x 0.084" Microstrip
Z10, Z11	1.280" x 0.046" Microstrip	Z23	0.199" x 0.057" Microstrip
Z12	0.053" x 1.080" Microstrip	PCB	Arlon GX0300-55-22, 0.03", $\epsilon_r = 2.55$

Figure 1. MRF5S19130R3(SR3) Test Circuit Schematic

Table 1. MRF5S19130R3(SR3) Test Circuit Component Designations and Values

Part	Description	Value, P/N or DWG	Manufacturer
B1, B2	Short RF Bead	95F786	Newark
C1	0.8 pF Chip Capacitor, B Case	100B0R8BP 500X	ATC
C2, C4	0.6 – 4.5 pF Gigatrim Variable Capacitors	44F3358	Newark
C3	2.2 pF Chip Capacitor, B Case	100B2R2BP 500X	ATC
C5	1.7 pF Chip Capacitor, B Case	100B1R7BP 500X	ATC
C8, C13	9.1 pF Chip Capacitors, B Case	100B9R1CP 500X	ATC
C9, C11	1 $\mu$ F, 25 V Tantalum Capacitors	92F1845	Newark
C10	47 $\mu$ F, 50 V Electrolytic Capacitor	51F2913	Newark
C6, C14, C17, C18, C19, C28, C29, C30	0.1 $\mu$ F Chip Capacitors, B Case	CDR33BX104AKWS	Kemet
C7, C12, C16, C27	1000 pF Chip Capacitors, B Case	100B102JP 500X	ATC
C15, C26	8.2 pF Chip Capacitors, B Case	100B8R2CP 500X	ATC
C20, C21, C22, C23, C31, C32, C33, C34	22 $\mu$ F, 35 V Tantalum Capacitors	92F1853	Newark
C24	470 $\mu$ F, 63 V Electrolytic Capacitor	95F4579	Newark
C25	6.2 pF Chip Capacitor, B Case	100B6R2CP 500X	ATC
R1	1 k $\Omega$ Chip Resistor	D5534M07B1K00R	Newark
R2	560 k $\Omega$ Chip Resistor	CR1206 564JT	Newark
R3, R4	12 $\Omega$ Chip Resistors	RM73B2B120JT	Garrett Electronics

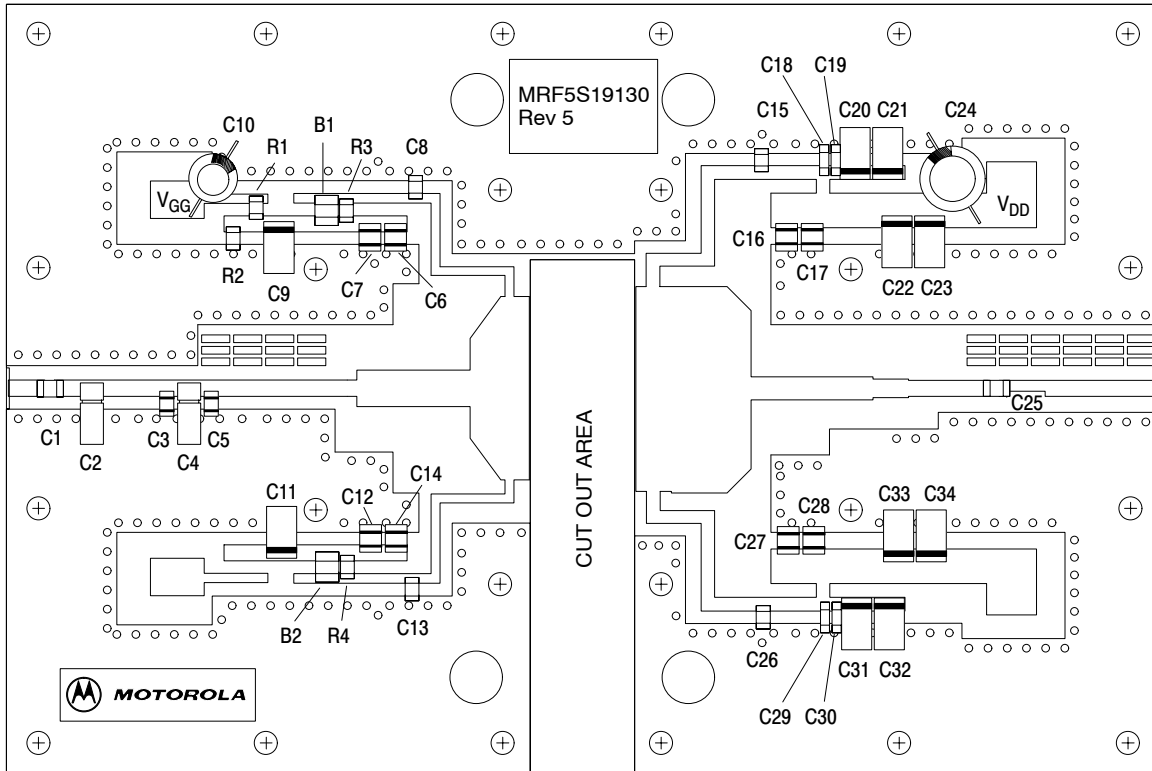

Figure 2. MRF5S19130R3(SR3) Test Circuit Component Layout

ARCHIVE INFORMATION

ARCHIVE INFORMATION

# Freescale Semiconductor, Inc.

## TYPICAL CHARACTERISTICS

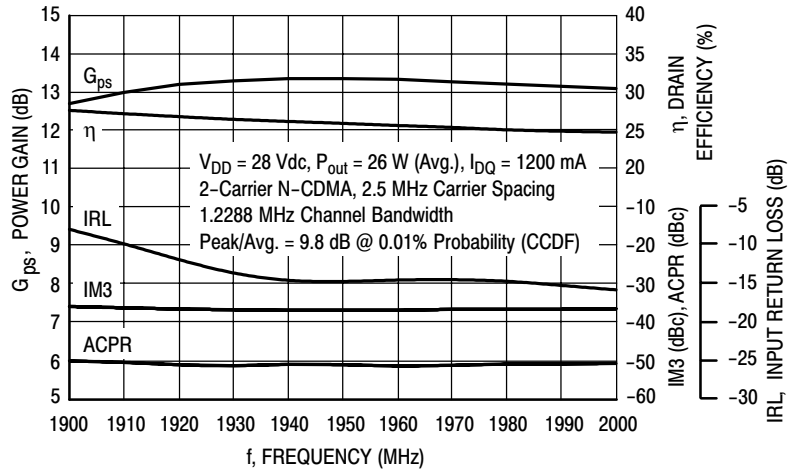

Figure 3. 2-Carrier N-CDMA Broadband Performance

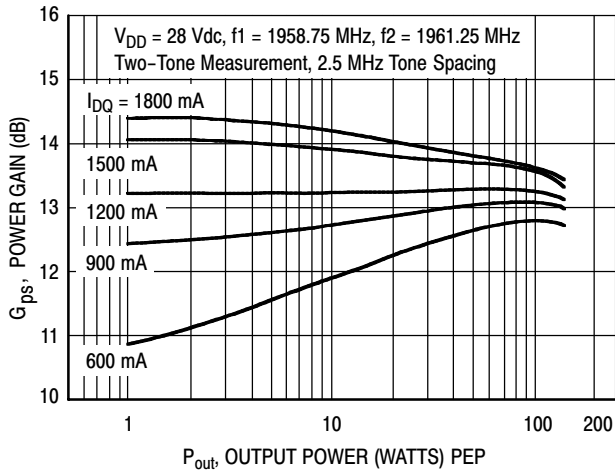

Figure 4. Two-Tone Power Gain versus Output Power

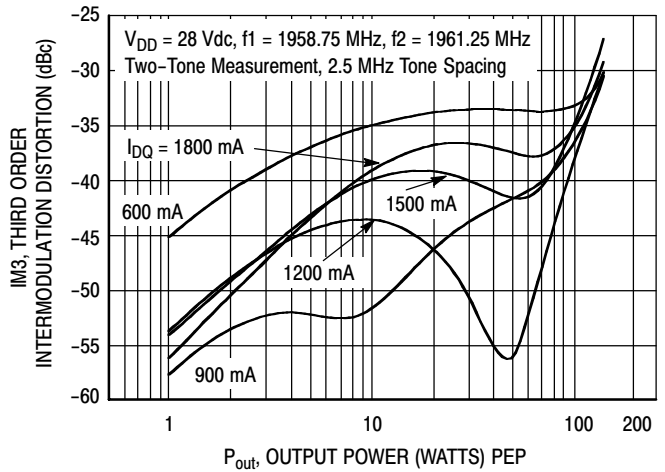

Figure 5. Third Order Intermodulation Distortion versus Output Power

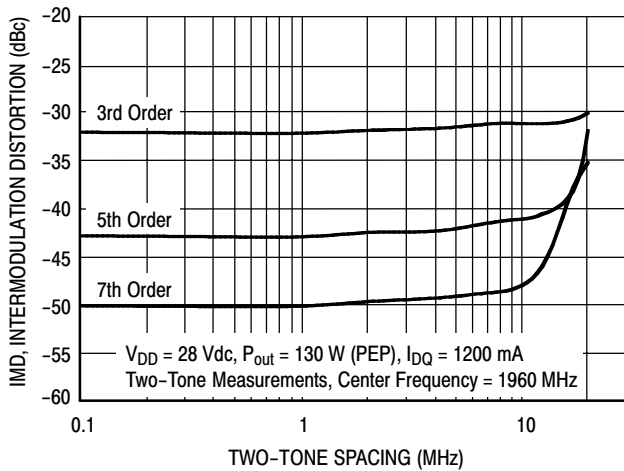

Figure 6. Intermodulation Distortion Products versus Tone Spacing

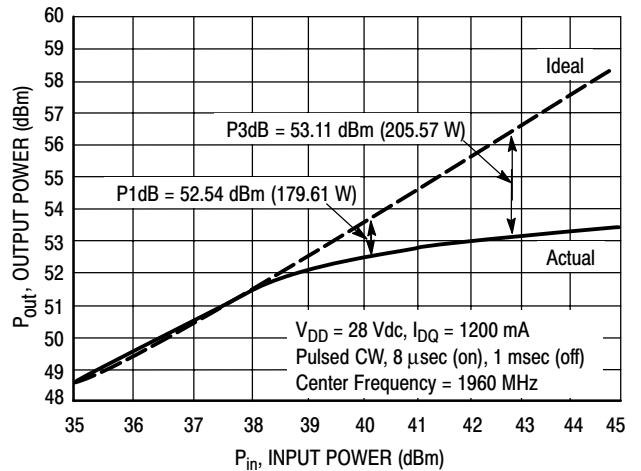
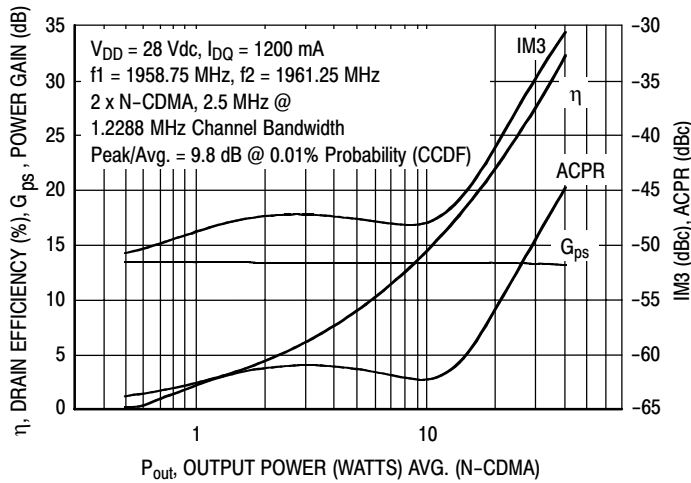

Figure 7. Pulse CW Output Power versus Input Power

Freescale Semiconductor, Inc. ARCHIVE INFORMATION

ARCHIVE INFORMATION

## TYPICAL CHARACTERISTICS



**Figure 8. 2-Carrier N-CDMA ACPR, IM3, Power Gain and Drain Efficiency versus Output Power**

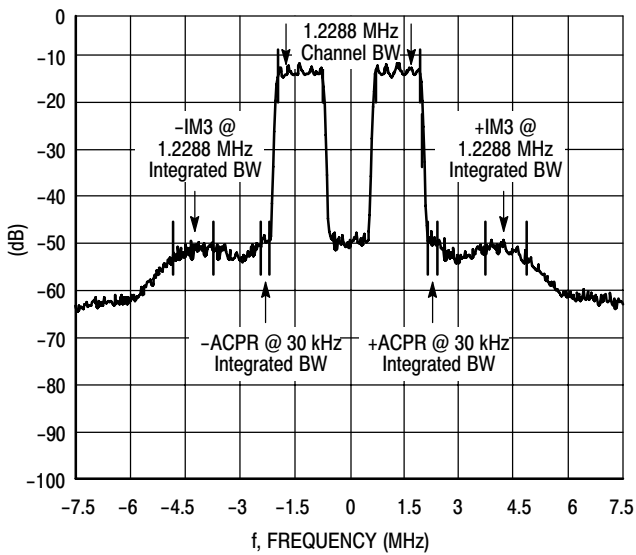

**Figure 9. 2-Carrier N-CDMA Spectrum**

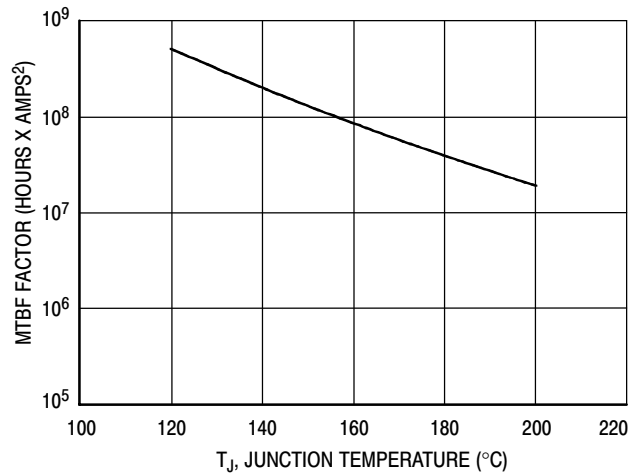

This above graph displays calculated MTBF in hours x ampere<sup>2</sup> drain current. Life tests at elevated temperatures have correlated to better than  $\pm 10\%$  of the theoretical prediction for metal failure. Divide MTBF factor by  $I_D^2$  for MTBF in a particular application.

**Figure 10. MTBF Factor versus Junction Temperature**

ARCHIVE INFORMATION

ARCHIVE INFORMATION

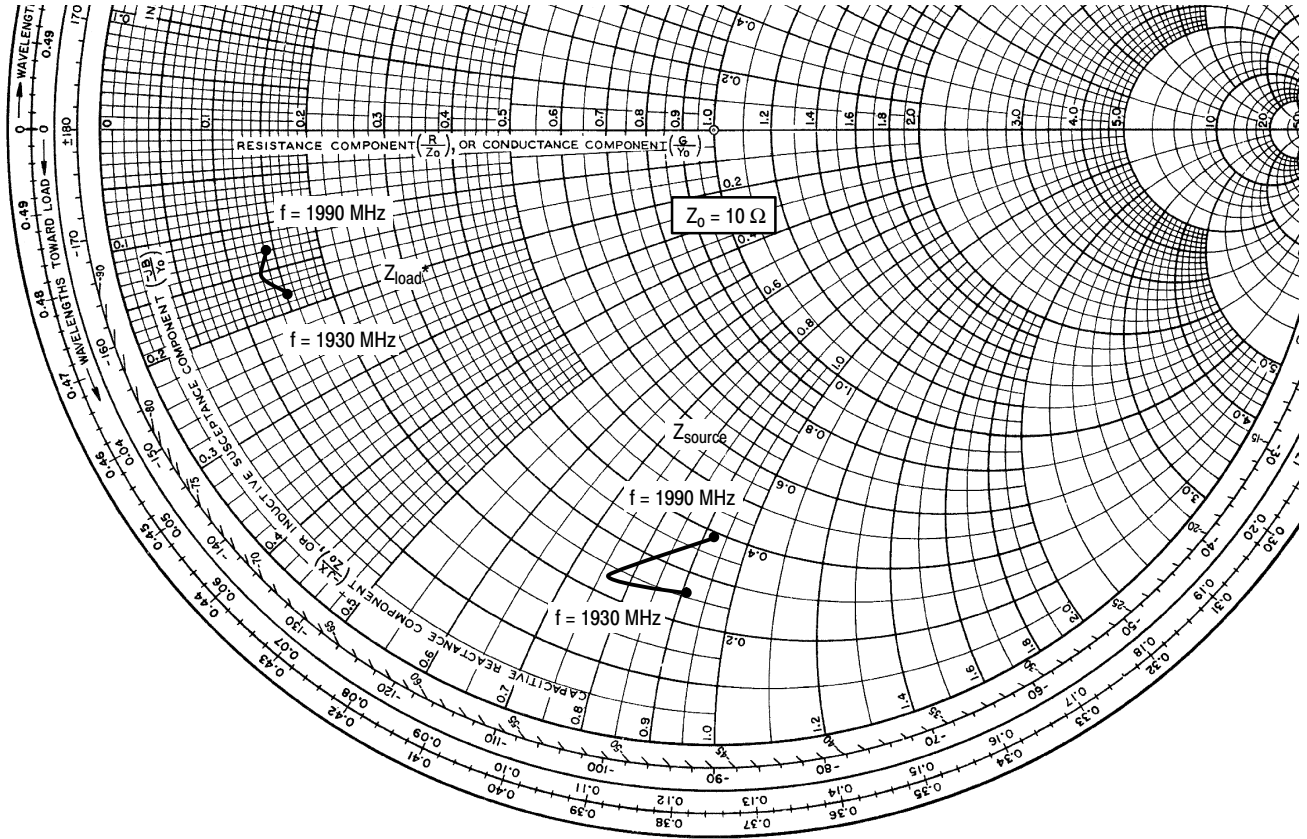

$V_{DD} = 28\text{ V}$ ,  $I_{DQ} = 1.2\text{ A}$ ,  $P_{out} = 26\text{ W}$  (2-Carrier N-CDMA)

f MHz	$Z_{source}$ $\Omega$	$Z_{load}$ $\Omega$
1930	$2.57 - j9.1$	$1.48 - j1.8$
1960	$2.35 - j7.6$	$1.28 - j1.5$
1990	$3.86 - j9.2$	$1.42 - j1.3$

$Z_{source}$  = Test circuit impedance as measured from gate to ground.

$Z_{load}$  = Test circuit impedance as measured from drain to ground.

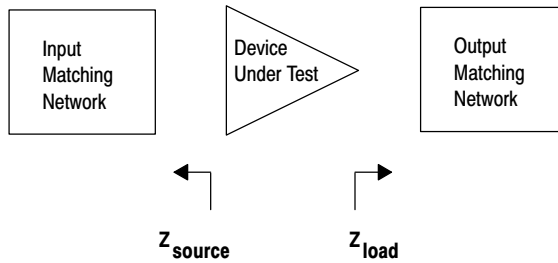

Figure 11. Series Equivalent Source and Load Impedance

**NOTES**

ARCHIVE INFORMATION

ARCHIVE INFORMATION



**NOTES**

ARCHIVE INFORMATION

ARCHIVE INFORMATION

# Freescale Semiconductor, Inc.

## PACKAGE DIMENSIONS

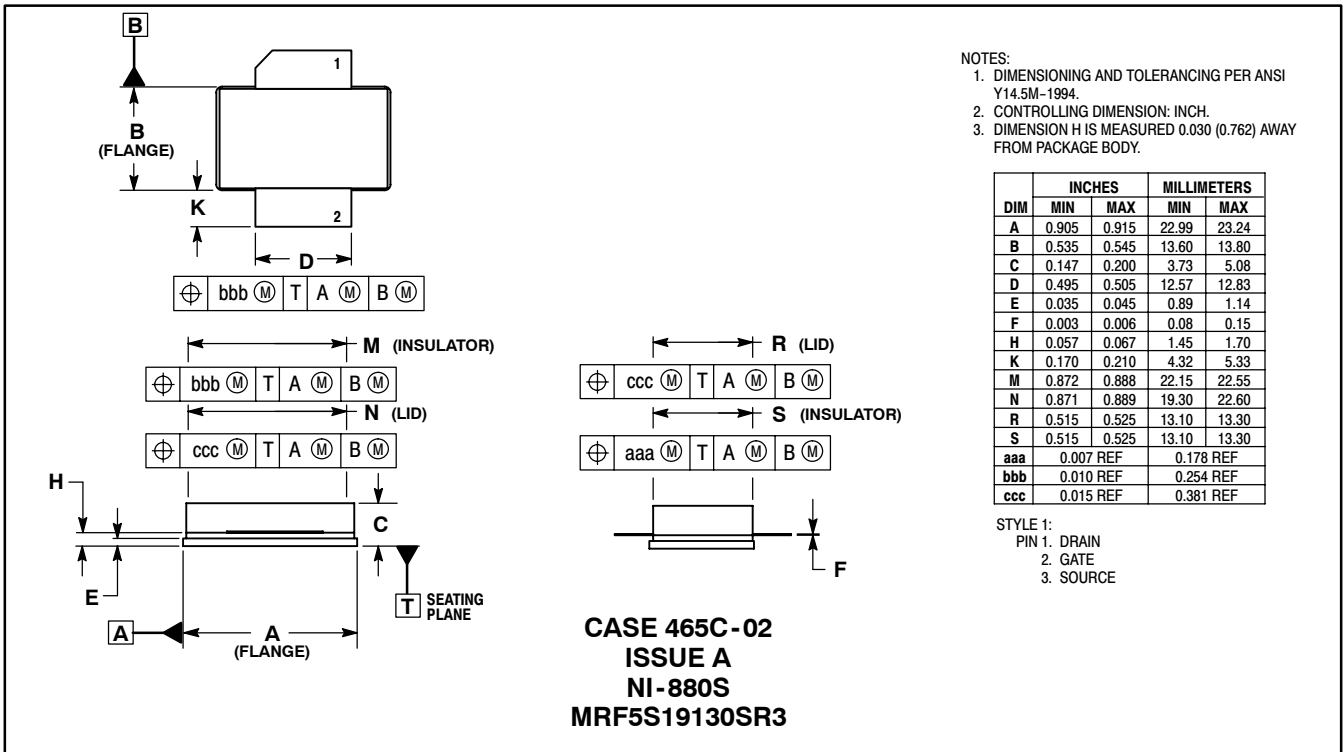
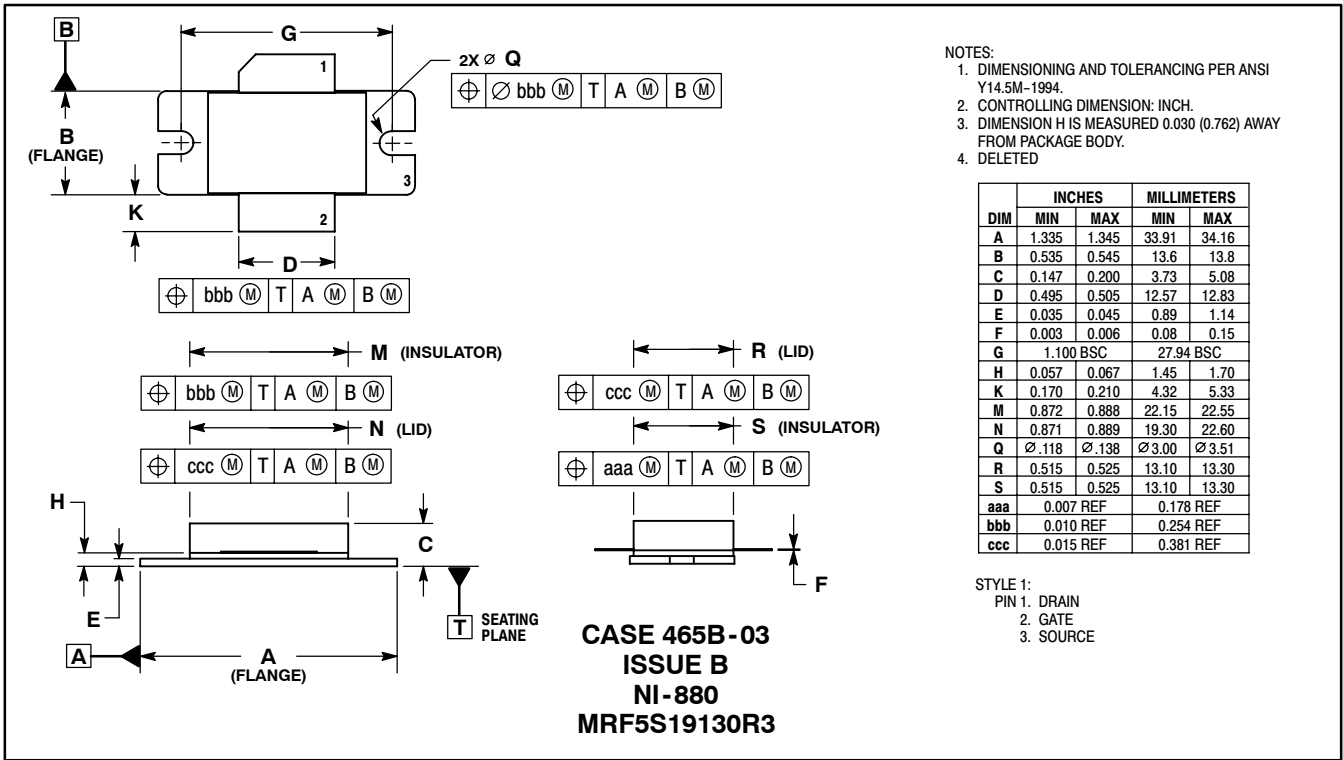

Freescale Semiconductor, Inc. ARCHIVE INFORMATION

ARCHIVE INFORMATION

Information in this document is provided solely to enable system and software implementers to use Motorola products. There are no express or implied copyright licenses granted hereunder to design or fabricate any integrated circuits or integrated circuits based on the information in this document.

Motorola reserves the right to make changes without further notice to any products herein. Motorola makes no warranty, representation or guarantee regarding the suitability of its products for any particular purpose, nor does Motorola assume any liability arising out of the application or use of any product or circuit, and specifically disclaims any and all liability, including without limitation consequential or incidental damages. "Typical" parameters that may be provided in Motorola data sheets and/or specifications can and do vary in different applications and actual performance may vary over time. All operating parameters, including "Typicals", must be validated for each customer application by customer's technical experts. Motorola does not convey any license under its patent rights nor the rights of others. Motorola products are not designed, intended, or authorized for use as components in systems intended for surgical implant into the body, or other applications intended to support or sustain life, or for any other application in which the failure of the Motorola product could create a situation where personal injury or death may occur. Should Buyer purchase or use Motorola products for any such unintended or unauthorized application, Buyer shall indemnify and hold Motorola and its officers, employees, subsidiaries, affiliates, and distributors harmless against all claims, costs, damages, and expenses, and reasonable attorney fees arising out of, directly or indirectly, any claim of personal injury or death associated with such unintended or unauthorized use, even if such claim alleges that Motorola was negligent regarding the design or manufacture of the part.

MOTOROLA and the Stylized M Logo are registered in the US Patent and Trademark Office. All other product or service names are the property of their respective owners. Motorola, Inc. is an Equal Opportunity/Affirmative Action Employer.

© Motorola Inc. 2003

#### HOW TO REACH US:

**USA/EUROPE/LOCATIONS NOT LISTED:**  
Motorola Literature Distribution  
P.O. Box 5405, Denver, Colorado 80217  
1-800-521-6274 or 480-768-2130

**JAPAN:** Motorola Japan Ltd.; SPS, Technical Information Center,  
3-20-1, Minami-Azabu, Minato-ku, Tokyo 106-8573, Japan  
81-3-3440-3569

**ASIA/PACIFIC:** Motorola Semiconductors H.K. Ltd.; Silicon Harbour Centre,  
2 Dai King Street, Tai Po Industrial Estate, Tai Po, N.T., Hong Kong  
852-26668334

**HOME PAGE:** <http://motorola.com/semiconductors>



**MOTOROLA**

**For More Information On This Product,  
Go to: [www.freescale.com](http://www.freescale.com)**

**MRF5S19130/D**