

RF Power Field Effect Transistors

N-Channel Enhancement-Mode Lateral MOSFETs

Designed for Class A and Class AB PCN and PCS base station applications with frequencies up to 2600 MHz. Suitable for FM, TDMA, CDMA, and multicarrier amplifier applications.

- Specified Two-Tone Performance @ 2000 MHz, 26 Volts
Output Power — 10 Watts PEP
Power Gain — 10.5 dB
Efficiency — 28%
Intermodulation Distortion — -31 dBc
- Specified Single-Tone Performance @ 2000 MHz, 26 Volts
Output Power — 10 Watts CW
Power Gain — 9.5 dB
Efficiency — 35%
- Capable of Handling 10:1 VSWR, @ 26 Vdc,
2000 MHz, 10 Watts CW Output Power

Features

- Excellent Thermal Stability
- Characterized with Series Equivalent Large-Signal Impedance Parameters
- RoHS Compliant
- Available in Tape and Reel. R1 Suffix = 500 Units per 12 mm, 7 inch Reel.

MRF282SR1
MRF282ZR1

2000 MHz, 10 W, 26 V
LATERAL N-CHANNEL
BROADBAND
RF POWER MOSFETs

CASE 458B-03, STYLE 1
NI-200S
MRF282SR1



CASE 458C-03, STYLE 1
NI-200Z
MRF282ZR1

Table 1. Maximum Ratings

Rating	Symbol	Value	Unit
Drain-Source Voltage	V_{DSS}	-0.5, +65	Vdc
Gate-Source Voltage	V_{GS}	±20	Vdc
Total Device Dissipation @ $T_C = 25^\circ\text{C}$ Derate above 25°C	P_D	60 0.34	W $\text{W}/^\circ\text{C}$
Storage Temperature Range	T_{stg}	-65 to +150	$^\circ\text{C}$
Case Operating Temperature	T_C	150	$^\circ\text{C}$
Operating Junction Temperature	T_J	200	$^\circ\text{C}$

Table 2. Thermal Characteristics

Characteristic	Symbol	Value	Unit
Thermal Resistance, Junction to Case	$R_{\theta JC}$	4.2	$^\circ\text{C}/\text{W}$

Table 3. Electrical Characteristics ($T_C = 25^\circ\text{C}$ unless otherwise noted)

Characteristic	Symbol	Min	Typ	Max	Unit
----------------	--------	-----	-----	-----	------

Off Characteristics

Drain-Source Breakdown Voltage ($V_{GS} = 0$, $I_D = 10 \mu\text{A}$)	$V_{(BR)DSS}$	65	—	—	Vdc
Zero Gate Voltage Drain Current ($V_{DS} = 28 \text{ Vdc}$, $V_{GS} = 0$)	I_{DSS}	—	—	1.0	μA
Gate-Source Leakage Current ($V_{GS} = 20 \text{ Vdc}$, $V_{DS} = 0$)	I_{GSS}	—	—	1.0	μA

NOTE - CAUTION - MOS devices are susceptible to damage from electrostatic charge. Reasonable precautions in handling and packaging MOS devices should be observed.

Table 3. Electrical Characteristics ($T_C = 25^\circ\text{C}$ unless otherwise noted) (continued)

Characteristic	Symbol	Min	Typ	Max	Unit
On Characteristics					
Gate Threshold Voltage ($V_{DS} = 10\text{ Vdc}$, $I_D = 50\ \mu\text{Adc}$)	$V_{GS(th)}$	2.0	3.0	4.0	Vdc
Drain-Source On-Voltage ($V_{GS} = 10\text{ Vdc}$, $I_D = 0.5\text{ Adc}$)	$V_{DS(on)}$	—	0.4	0.6	Vdc
Gate Quiescent Voltage ($V_{DS} = 26\text{ Vdc}$, $I_D = 75\text{ mA}$)	$V_{GS(q)}$	3.0	4.0	5.0	Vdc
Dynamic Characteristics					
Input Capacitance ($V_{DS} = 26\text{ Vdc}$, $V_{GS} = 0$, $f = 1.0\text{ MHz}$)	C_{iss}	—	15	—	pF
Output Capacitance ($V_{DS} = 26\text{ Vdc}$, $V_{GS} = 0$, $f = 1.0\text{ MHz}$)	C_{oss}	—	8.0	—	pF
Reverse Transfer Capacitance ($V_{DS} = 26\text{ Vdc}$, $V_{GS} = 0$, $f = 1.0\text{ MHz}$)	C_{rss}	—	0.45	—	pF
Functional Tests (In Freescale Test Fixture)					
Common-Source Power Gain ($V_{DD} = 26\text{ Vdc}$, $P_{out} = 10\text{ W PEP}$, $I_{DQ} = 75\text{ mA}$, $f_1 = 2000.0\text{ MHz}$, $f_2 = 2000.1\text{ MHz}$)	G_{ps}	10.5	11.5	—	dB
Drain Efficiency ($V_{DD} = 26\text{ Vdc}$, $P_{out} = 10\text{ W PEP}$, $I_{DQ} = 75\text{ mA}$, $f_1 = 2000.0\text{ MHz}$, $f_2 = 2000.1\text{ MHz}$)	η	28	—	—	%
Intermodulation Distortion ($V_{DD} = 26\text{ Vdc}$, $P_{out} = 10\text{ W PEP}$, $I_{DQ} = 75\text{ mA}$, $f_1 = 2000.0\text{ MHz}$, $f_2 = 2000.1\text{ MHz}$)	IMD	—	-31	-28	dBc
Input Return Loss ($V_{DD} = 26\text{ Vdc}$, $P_{out} = 10\text{ W PEP}$, $I_{DQ} = 75\text{ mA}$, $f_1 = 2000.0\text{ MHz}$, $f_2 = 2000.1\text{ MHz}$)	IRL	—	-14	-9	dB
Common-Source Power Gain ($V_{DD} = 26\text{ Vdc}$, $P_{out} = 10\text{ W PEP}$, $I_{DQ} = 75\text{ mA}$, $f_1 = 1930.0\text{ MHz}$, $f_2 = 1930.1\text{ MHz}$)	G_{ps}	10.5	11.5	—	dB
Drain Efficiency ($V_{DD} = 26\text{ Vdc}$, $P_{out} = 10\text{ W PEP}$, $I_{DQ} = 75\text{ mA}$, $f_1 = 1930.0\text{ MHz}$, $f_2 = 1930.1\text{ MHz}$)	η	28	—	—	%
Intermodulation Distortion ($V_{DD} = 26\text{ Vdc}$, $P_{out} = 10\text{ W PEP}$, $I_{DQ} = 75\text{ mA}$, $f_1 = 1930.0\text{ MHz}$, $f_2 = 1930.1\text{ MHz}$)	IMD	—	-31	-28	dBc
Input Return Loss ($V_{DD} = 26\text{ Vdc}$, $P_{out} = 10\text{ W PEP}$, $I_{DQ} = 75\text{ mA}$, $f_1 = 1930.0\text{ MHz}$, $f_2 = 1930.1\text{ MHz}$)	IRL	—	-14	-9	dB
Common-Source Power Gain ($V_{DD} = 26\text{ Vdc}$, $P_{out} = 10\text{ W CW}$, $I_{DQ} = 75\text{ mA}$, $f = 2000.0\text{ MHz}$)	G_{ps}	9.5	11.5	—	dB
Drain Efficiency ($V_{DD} = 26\text{ Vdc}$, $P_{out} = 10\text{ W CW}$, $I_{DQ} = 75\text{ mA}$, $f = 2000.0\text{ MHz}$)	η	35	40	—	%

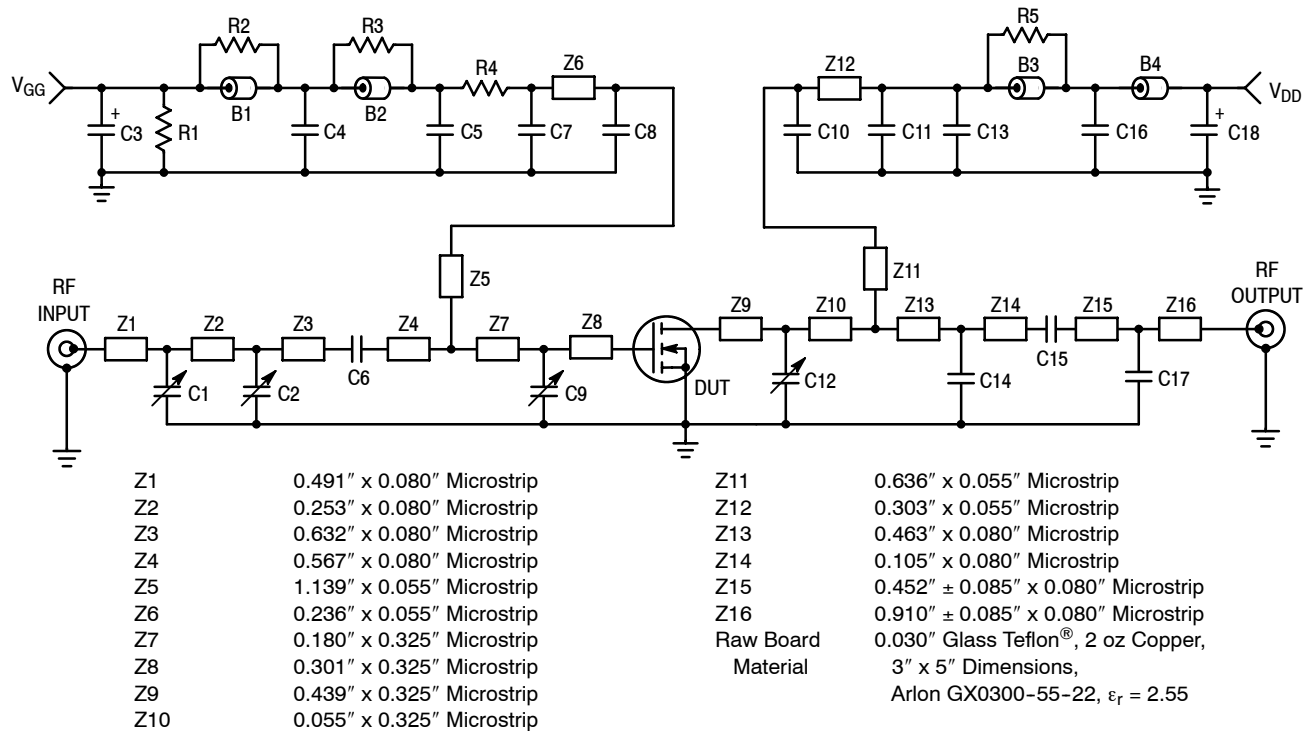
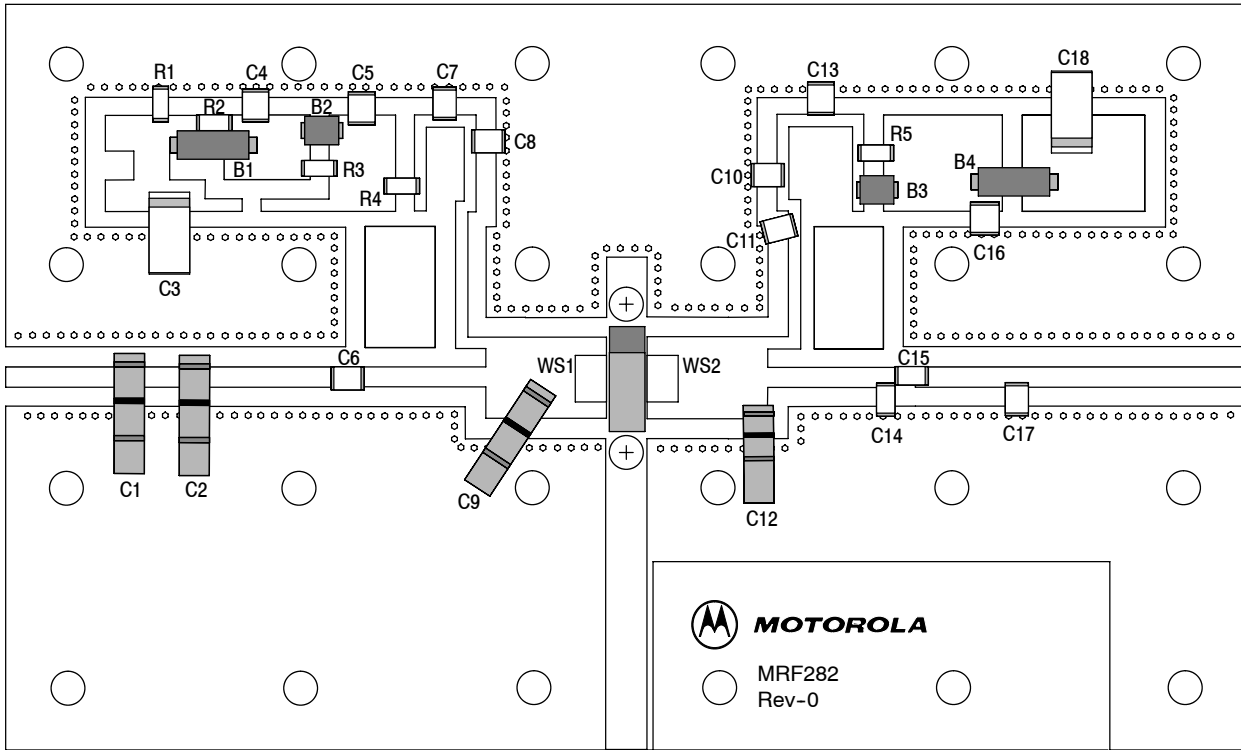

Figure 1. 1930 - 2000 MHz Broadband Test Circuit Schematic

Table 4. 1930 - 2000 MHz Broadband Test Circuit Component Designations and Values

Designators	Description
B1, B4	Surface Mount Ferrite Beads, 0.120" x 0.333" x 0.100", Fair Rite #2743019446
B2, B3	Surface Mount Ferrite Beads, 0.120" x 0.170" x 0.100", Fair Rite #2743029446
C1, C2, C9	0.8-8.0 pF Variable Capacitors, Johanson Gigatrim #27291SL
C3	10 μF, 35 V Tantalum Surface Mount Chip Capacitor, Kemet #T495X106K035AS4394
C4, C5, C13, C16	0.1 μF Chip Capacitors, Kemet #CDR33BX104AKWS
C6	200 pF Chip Capacitor, ATC #100B201JCA500X
C7	18 pF Chip Capacitor, ATC #100B180KP500X
C8	39 pF Chip Capacitor, ATC #100B390JCA500X
C10	27 pF Chip Capacitor, ATC #100B270JCA500X
C11	1.2 pF Chip Capacitor, ATC #100B1R2CCA500X
C12	0.6-4.5 pF Variable Capacitor, Johanson Gigatrim #27271SL
C14	0.5 pF Chip Capacitor, ATC #100B0R5BCA500X
C15	15 pF Chip Capacitor, ATC #100B150JCA500X
C17	0.1 pF Chip Capacitor, ATC #100B0R1BCA500X
C18	22 μF, 35 V Tantalum Surface Mount Chip Capacitor, Kemet #T491X226K035AS4394
R1	560 kΩ, 1/4 W Chip Resistor, 0.08" x 0.13"
R2, R5	12 Ω, 1/4 W Chip Resistors, 0.08" x 0.13", Garrett Instruments #RM73B2B120JT
R3, R4	91 Ω, 1/4 W Chip Resistors, 0.08" x 0.13", Garrett Instruments #RM73B2B910JT
WS1, WS2	Beryllium Copper Wear Blocks 0.010" x 0.235" x 0.135" NOM
	Brass Banana Jack and Nut
	Red Banana Jack and Nut
	Green Banana Jack and Nut
	Type "N" Jack Connectors, Omni-Spectra # 3052-1648-10
	4-40 Ph Head Screws, 0.125" Long
	4-40 Ph Head Screws, 0.188" Long
	4-40 Ph Head Screws, 0.312" Long
	4-40 Ph Rec. Hd. Screws, 0.438" Long
RF Circuit Board	3" x 5" Copper Clad PCB, Glass Teflon®



Freescale has begun the transition of marking Printed Circuit Boards (PCBs) with the Freescale Semiconductor signature/logo. PCBs may have either Motorola or Freescale markings during the transition period. These changes will have no impact on form, fit or function of the current product.

Figure 2. 1930 - 2000 MHz Broadband Test Circuit Component Layout

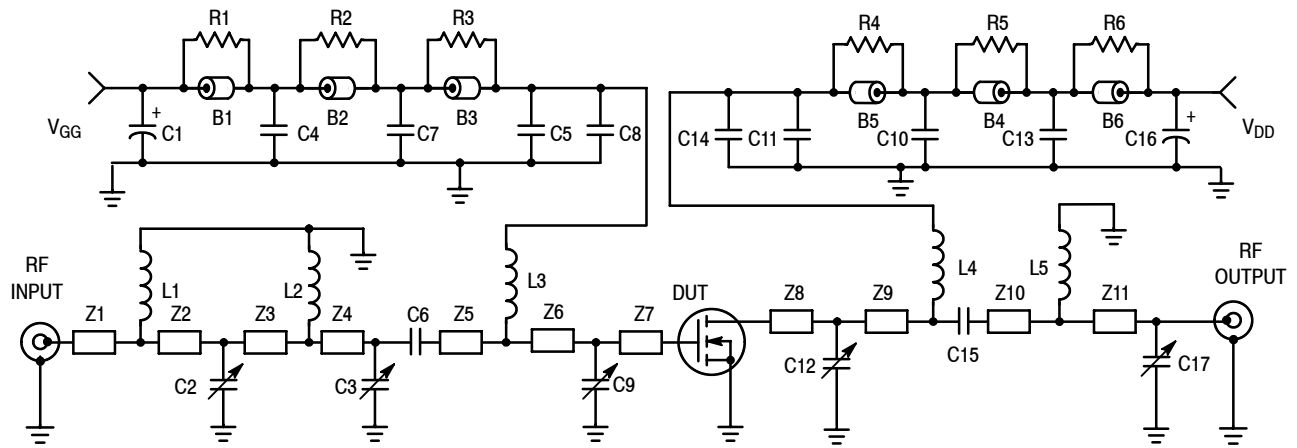

Z1	0.122" x 0.08" Microstrip	Z8	0.414" x 0.330" Microstrip
Z2	0.650" x 0.08" Microstrip	Z9	0.392" x 0.08" Microstrip
Z3	0.160" x 0.08" Microstrip	Z10	0.070" x 0.08" Microstrip
Z4	0.030" x 0.08" Microstrip	Z11	1.110" x 0.08" Microstrip
Z5	0.045" x 0.08" Microstrip	Raw Board	0.030" Glass Teflon®, 2 oz Copper,
Z6	0.291" x 0.08" Microstrip	Material	3" x 5" Dimensions,
Z7	0.483" x 0.330" Microstrip		Arlon GX0300-55-22, $\epsilon_r = 2.55$

Figure 3. 1810 - 1880 MHz Broadband Test Circuit Schematic

Table 5. 1810 - 1880 MHz Broadband Test Circuit Component Designations and Values

Designators	Description
B1, B2, B3, B4, B5, B6	Surface Mount Ferrite Beads, 0.120" x 0.170" x 0.100", Fair Rite #2743029446
C1, C16	470 μ F, 63 V Electrolytic Capacitors, Mallory #SME63UB471M12X25L
C2, C9, C12, C17	0.6-4.5 pF Variable Capacitors, Johanson Gigatrim #27271SL
C3	0.8-8.0 pF Variable Capacitor, Johanson Gigatrim #27291SL
C4, C13	0.1 μ F Chip Capacitors, Kemet #CDR33BX104AKWS
C5, C14	100 pF Chip Capacitors, ATC #100B101JCA500X
C6, C8, C11, C15	12 pF Chip Capacitors, ATC #100B120JCA500X
C7, C10	1000 pF Chip Capacitors, ATC #100B102JCA50X
L1	3 Turns, 27 AWG, 0.087" OD, 0.050" ID, 0.053" Long, 6.0 nH
L2	5 Turns, 27 AWG, 0.087" OD, 0.050" ID, 0.091" Long, 15 nH
L3, L4	9 Turns, 26 AWG, 0.080" OD, 0.046" ID, 0.170" Long, 30.8 nH
L5	4 Turns, 27 AWG, 0.087" OD, 0.050" ID, 0.078" Long, 10 nH
R1, R2, R3	12 Ω , 1/8 W Fixed Film Chip Resistors, Garrett Instruments #RM73B2B120JT
R4, R5, R6	0.08" x 0.13" Resistors, Garrett Instruments #RM73B2B120JT
W1, W2	Beryllium Copper 0.010" x 0.110" x 0.210"

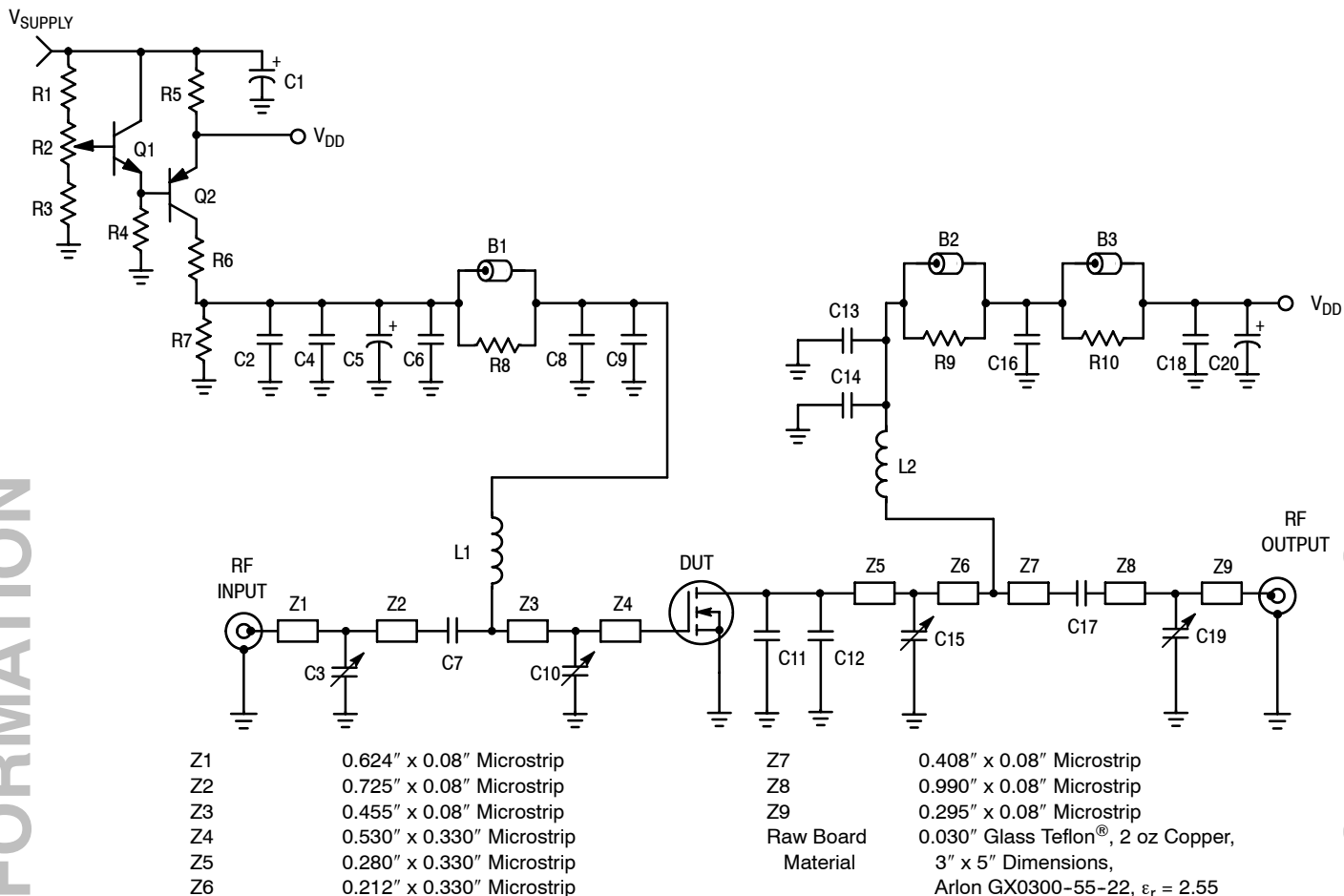
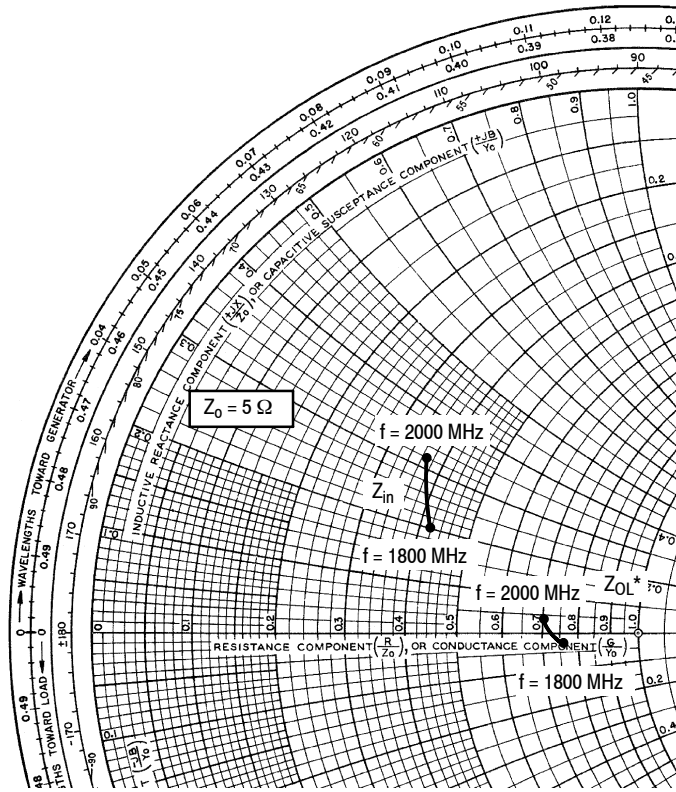

Figure 4. Class A Broadband Test Circuit Schematic

Table 6. Class A Broadband Test Circuit Component Designations and Values

Designators	Description
B1, B2, B3	Ferrite Beads, Ferroxcube #56-590-65-3B
C1, C20	470 μ F, 63 V Electrolytic Capacitors, Mallory #SME63V471M12X25L
C2	0.01 μ F Chip Capacitor, ATC #100B103JCA50X
C3, C10, C15	0.6-4.5 pF Variable Capacitors, Johanson #27271SL
C4, C16	0.02 μ F Chip Capacitors, ATC #100B203JCA50X
C5	100 μ F, 50 V Electrolytic Capacitor, Mallory #SME50VB101M12X256
C6, C7, C9, C14, C17	12 pF Chip Capacitors, ATC #100B120JCA500X
C8, C13	51 pF Chip Capacitors, ATC #100B510JCA500X
C11, C12	0.3 pF Chip Capacitors, ATC #100B0R3CCA500X
C18	0.1 μ F Chip Capacitor, Kemet #CDR33BX104AKWS
C19	0.4-2.5 pF Variable Capacitor, Johanson #27285
L1	8 Turns, 0.042" ID, 24 AWG, Enamel
L2	9 Turns, 0.046" ID, 26 AWG, Enamel
Q1	NPN, 15 W, Bipolar Transistor, MJD310
Q2	PNP, 15 W, Bipolar Transistor, MJD320
R1	200 Ω , 1/4 W Axial Resistor
R2	1.0 k Ω , 1/2 W Potentiometer, Bourns
R3	13 k Ω , 1/4 W Axial Resistor
R4, R6, R7	390 Ω , 1/8 W Chip Resistors, Garrett Instruments #RM73B2B391JT
R5	1.0 Ω , 10 W 1% Resistor, Dale #RE65G1R00
R8, R9, R10	12 Ω , 1/8 W Chip Resistors, Garrett Instruments #RM73B2B120JT
Input/Output	Type N Flange Mount RF55-22 Connectors, Omni-Spectra

MRF282SR1 MRF282ZR1



$V_{DD} = 26\text{ V}$, $I_{DQ} = 75\text{ mA}$, $P_{out} = 10\text{ W (PEP)}$

f MHz	Z_{in} Ω	Z_{OL}^* Ω
1800	$2.1 + j1.0$	$3.8 - j0.15$
1860	$2.05 + j1.15$	$3.77 - j0.13$
1900	$2.0 + j1.2$	$3.75 - j0.1$
1960	$1.9 + j1.4$	$3.65 + j0.1$
2000	$1.85 + j1.6$	$3.55 + j0.2$

Z_{in} = Complex conjugate of source impedance.

Z_{OL}^* = Complex conjugate of the optimum load impedance at given output power, voltage, IMD, bias current and frequency.

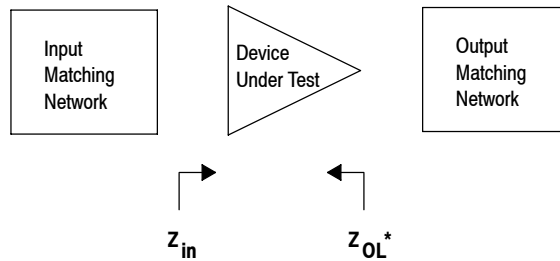

Figure 5. Series Equivalent Input and Output Impedance

NOTES

ARCHIVE INFORMATION

ARCHIVE INFORMATION

NOTES

ARCHIVE INFORMATION

ARCHIVE INFORMATION

NOTES

ARCHIVE INFORMATION

ARCHIVE INFORMATION

PACKAGE DIMENSIONS

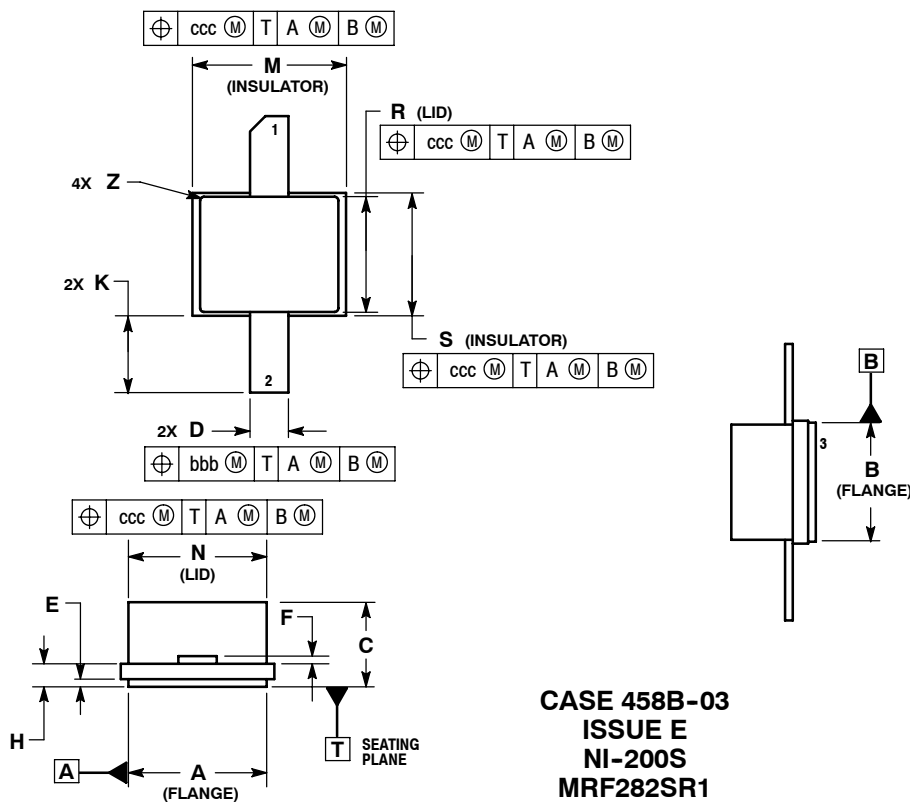

- NOTES:
1. CONTROLLING DIMENSIONS: INCHES.
 2. INTERPRET DIMENSIONS AND TOLERANCES PER ASME Y14.5M, 1994.
 3. ALL DIMENSIONS ARE SYMMETRICAL ABOUT CENTERLINE UNLESS OTHERWISE NOTED.

DIM	INCHES		MILLIMETERS	
	MIN	MAX	MIN	MAX
A	0.180	0.190	4.572	4.83
B	0.140	0.150	3.556	3.81
C	0.082	0.116	2.083	2.946
D	0.047	0.053	1.194	1.346
E	0.004	0.010	0.102	0.254
F	0.004	0.006	0.102	0.152
H	0.025	0.031	0.635	0.787
K	0.060	0.110	1.524	2.794
M	0.197	0.203	5.004	5.156
N	0.177	0.183	4.496	4.648
R	0.147	0.153	3.734	3.886
S	0.157	0.163	3.988	4.14
Z	---	0.020	---	0.508
bbb	.010 REF		0.254 REF	
ccc	.015 REF		0.381 REF	

- STYLE 1:
PIN 1. DRAIN
2. GATE
3. SOURCE

ARCHIVE INFORMATION

ARCHIVE INFORMATION

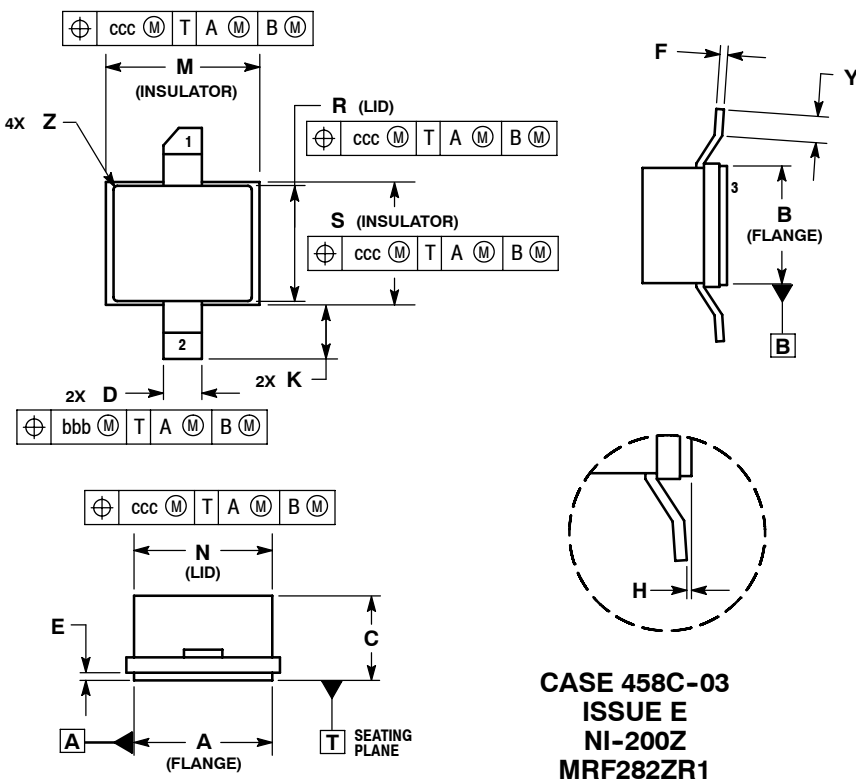

- NOTES:
1. CONTROLLING DIMENSIONS: INCHES.
 2. INTERPRET DIMENSIONS AND TOLERANCES PER ASME Y14.5M, 1994.
 3. DIMENSION H (PACKAGE COPLANARITY): THE BOTTOM OF LEADS AND REFERENCE PLANE T MUST BE COPLANAR WITHIN DIMENSION H.

DIM	INCHES		MILLIMETERS	
	MIN	MAX	MIN	MAX
A	0.180	0.190	4.572	4.830
B	0.140	0.150	3.556	3.810
C	0.082	0.116	2.083	2.946
D	0.047	0.053	1.194	1.346
E	0.004	0.010	0.102	0.254
F	0.004	0.006	0.102	0.152
H	0.000	0.004	0.000	0.102
K	0.050	0.090	1.270	2.286
M	0.197	0.203	5.004	5.156
N	0.177	0.183	4.496	4.648
R	0.147	0.153	3.734	3.886
S	0.157	0.163	3.988	4.140
Y	0.020	0.040	0.508	1.016
Z	---	R.020	---	R.508
bbb	.010 REF		0.254 REF	
ccc	.015 REF		0.381 REF	

- STYLE 1:
PIN 1. DRAIN
2. GATE
3. SOURCE

REVISION HISTORY

The following table summarizes revisions to this document.

Revision	Date	Description
15	Oct. 2008	<ul style="list-style-type: none">MRF282 Rev. 15 data sheet archived. Data sheet split due to change in part life cycle. See MRF282-1 Rev. 16 for MRF282SR1 and MRF282-2 Rev. 17 for MRF282ZR1.

ARCHIVE INFORMATION

ARCHIVE INFORMATION

How to Reach Us:

Home Page:
www.freescale.com

E-mail:
support@freescale.com

USA/Europe or Locations Not Listed:
Freescale Semiconductor
Technical Information Center, CH370
1300 N. Alma School Road
Chandler, Arizona 85224
+1-800-521-6274 or +1-480-768-2130
support@freescale.com

Europe, Middle East, and Africa:
Freescale Halbleiter Deutschland GmbH
Technical Information Center
Schatzbogen 7
81829 Muenchen, Germany
+44 1296 380 456 (English)
+46 8 52200080 (English)
+49 89 92103 559 (German)
+33 1 69 35 48 48 (French)
support@freescale.com

Japan:
Freescale Semiconductor Japan Ltd.
Headquarters
ARCO Tower 15F
1-8-1, Shimo-Meguro, Meguro-ku,
Tokyo 153-0064
Japan
0120 191014 or +81 3 5437 9125
support.japan@freescale.com

Asia/Pacific:
Freescale Semiconductor Hong Kong Ltd.
Technical Information Center
2 Dai King Street
Tai Po Industrial Estate
Tai Po, N.T., Hong Kong
+800 2666 8080
support.asia@freescale.com

For Literature Requests Only:
Freescale Semiconductor Literature Distribution Center
P.O. Box 5405
Denver, Colorado 80217
1-800-441-2447 or 303-675-2140
Fax: 303-675-2150
LDCForFreescaleSemiconductor@hibbertgroup.com

Information in this document is provided solely to enable system and software implementers to use Freescale Semiconductor products. There are no express or implied copyright licenses granted hereunder to design or fabricate any integrated circuits or integrated circuits based on the information in this document.

Freescale Semiconductor reserves the right to make changes without further notice to any products herein. Freescale Semiconductor makes no warranty, representation or guarantee regarding the suitability of its products for any particular purpose, nor does Freescale Semiconductor assume any liability arising out of the application or use of any product or circuit, and specifically disclaims any and all liability, including without limitation consequential or incidental damages. "Typical" parameters that may be provided in Freescale Semiconductor data sheets and/or specifications can and do vary in different applications and actual performance may vary over time. All operating parameters, including "Typicals", must be validated for each customer application by customer's technical experts. Freescale Semiconductor does not convey any license under its patent rights nor the rights of others. Freescale Semiconductor products are not designed, intended, or authorized for use as components in systems intended for surgical implant into the body, or other applications intended to support or sustain life, or for any other application in which the failure of the Freescale Semiconductor product could create a situation where personal injury or death may occur. Should Buyer purchase or use Freescale Semiconductor products for any such unintended or unauthorized application, Buyer shall indemnify and hold Freescale Semiconductor and its officers, employees, subsidiaries, affiliates, and distributors harmless against all claims, costs, damages, and expenses, and reasonable attorney fees arising out of, directly or indirectly, any claim of personal injury or death associated with such unintended or unauthorized use, even if such claim alleges that Freescale Semiconductor was negligent regarding the design or manufacture of the part.

Freescale™ and the Freescale logo are trademarks of Freescale Semiconductor, Inc. All other product or service names are the property of their respective owners.
© Freescale Semiconductor, Inc. 2006, 2008. All rights reserved.

