

**The RF MOSFET Line**  
**RF Power Field Effect Transistor**  
**N-Channel Enhancement-Mode Lateral MOSFET**

**MRF19120**

**1990 MHz, 120 W, 26 V**  
**LATERAL N-CHANNEL**  
**RF POWER MOSFET**

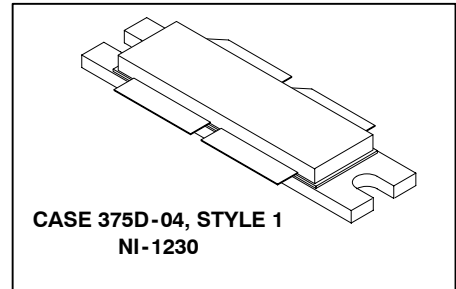

Designed for CDMA base station applications with frequencies from 1930 to 1990 MHz. Suitable for FM, TDMA, CDMA and multicarrier amplifier applications. To be used in Class AB for PCN-PCS/cellular radio and WLL applications.

- CDMA Performance @ 1990 MHz, 26 Volts  
 IS-97 CDMA Pilot, Sync, Paging, Traffic Codes 8 Thru 13  
 885 kHz — -47 dBc @ 30 kHz BW  
 1.25 MHz — -55 dBc @ 12.5 kHz BW  
 2.25 MHz — -55 dBc @ 1 MHz BW  
 Output Power — 15 Watts (Avg.)  
 Power Gain — 11.7 dB  
 Efficiency — 16%
- Internally Matched, Controlled Q, for Ease of Use
- High Gain, High Efficiency, High Linearity
- Integrated ESD Protection
- Designed for Maximum Gain and Insertion Phase Flatness
- Capable of Handling 10:1 VSWR, @ 26 Vdc, 1990 MHz, 120 Watts (CW) Output Power
- S-Parameter Characterization at High Bias Levels
- Excellent Thermal Stability
- Characterized with Series Equivalent Large-Signal Impedance Parameters

**MAXIMUM RATINGS**

Rating	Symbol	Value	Unit
Drain-Source Voltage	$V_{DSS}$	65	Vdc
Gate-Source Voltage	$V_{GS}$	- 0.5, +15	Vdc
Total Device Dissipation @ $T_C = 25^\circ\text{C}$ Derate above 25°C	$P_D$	389 2.22	Watts W/°C
Storage Temperature Range	$T_{stg}$	- 65 to +150	°C
Operating Junction Temperature	$T_J$	200	°C

**THERMAL CHARACTERISTICS**

Characteristic	Symbol	Value	Unit
Thermal Resistance, Junction to Case	$R_{\theta JC}$	0.45	°C/W

**ESD PROTECTION CHARACTERISTICS**

Test Conditions	Class
Human Body Model	1 (Minimum)
Machine Model	M3 (Minimum)

NOTE - **CAUTION** - MOS devices are susceptible to damage from electrostatic charge. Reasonable precautions in handling and packaging MOS devices should be observed.

Freescale Semiconductor, Inc. ARCHIVE INFORMATION

ARCHIVE INFORMATION

# Freescale Semiconductor, Inc.

## ELECTRICAL CHARACTERISTICS (T<sub>C</sub> = 25°C unless otherwise noted)

Characteristic	Symbol	Min	Typ	Max	Unit
<b>OFF CHARACTERISTICS (1)</b>					
Drain-Source Breakdown Voltage (V <sub>GS</sub> = 0 Vdc, I <sub>D</sub> = 10 μAdc)	V <sub>(BR)DSS</sub>	65	—	—	Vdc
Gate-Source Leakage Current (V <sub>GS</sub> = 5 Vdc, V <sub>DS</sub> = 0 Vdc)	I <sub>GSS</sub>	—	—	1	μAdc
Zero Gate Voltage Drain Leakage Current (V <sub>DS</sub> = 26 Vdc, V <sub>GS</sub> = 0 Vdc)	I <sub>DSS</sub>	—	—	10	μAdc
<b>ON CHARACTERISTICS (1)</b>					
Forward Transconductance (V <sub>DS</sub> = 10 Vdc, I <sub>D</sub> = 2 Adc)	g <sub>fs</sub>	—	4.8	—	S
Gate Threshold Voltage (V <sub>DS</sub> = 10 V, I <sub>D</sub> = 200 μA)	V <sub>GS(th)</sub>	2.5	3	3.8	Vdc
Gate Quiescent Voltage (V <sub>DS</sub> = 26 V, I <sub>D</sub> = 500 mA)	V <sub>GS(Q)</sub>	3	3.9	5	Vdc
Drain-Source On-Voltage (V <sub>GS</sub> = 10 V, I <sub>D</sub> = 2 A)	V <sub>DS(on)</sub>	—	0.38	0.5	Vdc
<b>DYNAMIC CHARACTERISTICS (1)</b>					
Reverse Transfer Capacitance (V <sub>DS</sub> = 26 Vdc, V <sub>GS</sub> = 0, f = 1 MHz)	C <sub>rss</sub>	—	2.8	—	pF
<b>FUNCTIONAL TESTS (In Motorola Test Fixture, 50 ohm system) (2)</b>					
Common-Source Amplifier Power Gain (V <sub>DD</sub> = 26 Vdc, P <sub>out</sub> = 120 W PEP, I <sub>DQ</sub> = 2 × 500 mA, f <sub>1</sub> = 1990.0 MHz, f <sub>2</sub> = 1990.1 MHz)	G <sub>ps</sub>	10.7	11.7	—	dB
Drain Efficiency (V <sub>DD</sub> = 26 Vdc, P <sub>out</sub> = 120 W PEP, I <sub>DQ</sub> = 2 × 500 mA, f <sub>1</sub> = 1990.0 MHz, f <sub>2</sub> = 1990.1 MHz)	η	30	34	—	%
Intermodulation Distortion (V <sub>DD</sub> = 26 Vdc, P <sub>out</sub> = 120 W PEP, I <sub>DQ</sub> = 2 × 500 mA, f <sub>1</sub> = 1990.0 MHz, f <sub>2</sub> = 1990.1 MHz)	IMD	—	-31	-28	dB
Input Return Loss (V <sub>DD</sub> = 26 Vdc, P <sub>out</sub> = 120 W PEP, I <sub>DQ</sub> = 2 × 500 mA, f <sub>1</sub> = 1990.0 MHz, f <sub>2</sub> = 1990.1 MHz)	IRL	—	-12	-9	dB
Common-Source Amplifier Power Gain (V <sub>DD</sub> = 26 Vdc, P <sub>out</sub> = 120 W PEP, I <sub>DQ</sub> = 2 × 500 mA, f <sub>1</sub> = 1930.0 MHz, f <sub>2</sub> = 1930.1 MHz)	G <sub>ps</sub>	—	11.7	—	dB
Drain Efficiency (V <sub>DD</sub> = 26 Vdc, P <sub>out</sub> = 120 W PEP, I <sub>DQ</sub> = 2 × 500 mA, f <sub>1</sub> = 1930.0 MHz, f <sub>2</sub> = 1930.1 MHz)	η	—	34	—	%
Intermodulation Distortion (V <sub>DD</sub> = 26 Vdc, P <sub>out</sub> = 120 W PEP, I <sub>DQ</sub> = 2 × 500 mA, f <sub>1</sub> = 1930.0 MHz, f <sub>2</sub> = 1930.1 MHz)	IMD	—	-31	—	dB
Input Return Loss (V <sub>DD</sub> = 26 Vdc, P <sub>out</sub> = 120 W PEP, I <sub>DQ</sub> = 2 × 500 mA, f <sub>1</sub> = 1930.0 MHz, f <sub>2</sub> = 1930.1 MHz)	IRL	—	-14	—	dB
Power Output, 1 dB Compression Point (V <sub>DD</sub> = 26 Vdc, CW, I <sub>DQ</sub> = 2 × 500 mA, f <sub>1</sub> = 1990.0 MHz)	P <sub>1dB</sub>	—	120	—	Watts
Common-Source Amplifier Power Gain (V <sub>DD</sub> = 26 Vdc, P <sub>out</sub> = 120 W CW, I <sub>DQ</sub> = 2 × 500 mA, f <sub>1</sub> = 1990.0 MHz)	G <sub>ps</sub>	—	11	—	dB

(1) Each side of device measured separately.

(2) Device measured in push-pull configuration.

(continued)

# Freescale Semiconductor, Inc.

## ELECTRICAL CHARACTERISTICS — continued ( $T_C = 25^\circ\text{C}$ unless otherwise noted)

Characteristic	Symbol	Min	Typ	Max	Unit
<b>FUNCTIONAL TESTS</b> (In Motorola Test Fixture, 50 ohm system) (2) (continued)					
Drain Efficiency ( $V_{DD} = 26 \text{ Vdc}$ , $P_{out} = 120 \text{ W CW}$ , $I_{DQ} = 2 \times 500 \text{ mA}$ , $f_1 = 1990.0 \text{ MHz}$ )	$\eta$	—	45	—	%
Output Mismatch Stress ( $V_{DD} = 26 \text{ Vdc}$ , $P_{out} = 120 \text{ W CW}$ , $I_{DQ} = 2 \times 500 \text{ mA}$ , $f = 1990 \text{ MHz}$ , $VSWR = 10:1$ , All Phase Angles at Frequency of Tests)	$\Psi$	No Degradation In Output Power Before and After Test			

(2) Device measured in push-pull configuration.

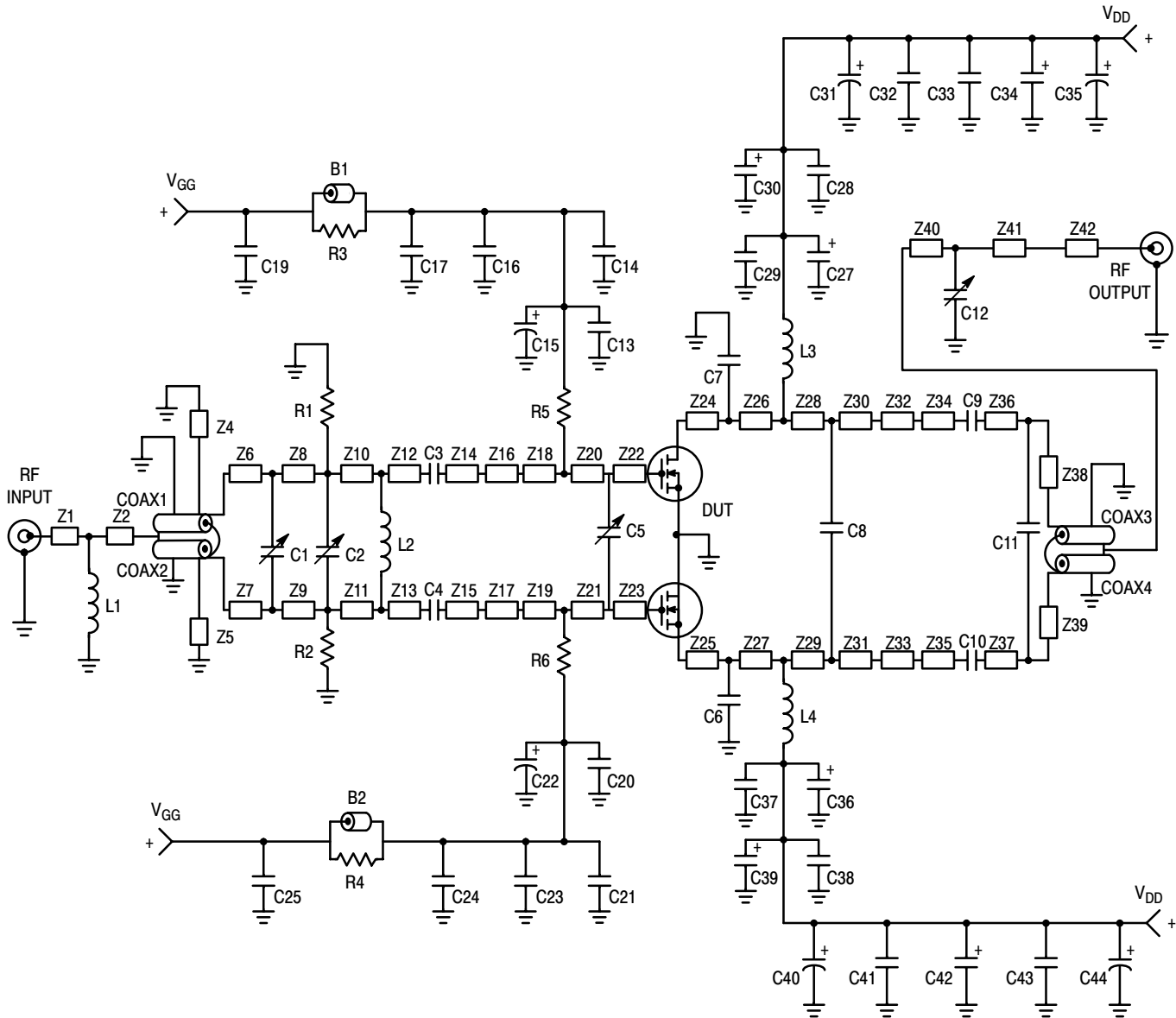

ARCHIVE INFORMATION

ARCHIVE INFORMATION

- B1, B2 Ferrite Beads, Fair Rite
- C1, C2 0.6 - 4.5 pF Variable Capacitors, Johanson Gigatrim
- C3, C4, C9, C10 10 pF Chip Capacitors, B Case, ATC
- C5, C12 0.4 - 2.5 pF Variable Capacitors, Johanson Gigatrim
- C6, C7 2.0 pF Chip Capacitors, B Case, ATC
- C8 1.1 pF Chip Capacitor, B Case, ATC
- C11 0.1 pF Chip Capacitor, B Case, ATC
- C13, C20, C29, C37 5.1 pF Chip Capacitors, B Case, ATC
- C14, C21, C28, C38 91 pF Chip Capacitors, B Case, ATC
- C15, C22, C31, C40 100  $\mu$ F, 50 V Electrolytic Capacitors, Sprague
- C16, C23, C33, C43 0.039  $\mu$ F Chip Capacitors, B Case, ATC
- C17, C24, C32, C41 1000 pF Chip Capacitors, B Case, ATC
- C19, C25 0.020  $\mu$ F Chip Capacitors, B Case, ATC
- C27, C34, C36, C42 22  $\mu$ F, 35 V Tantalum Surface Mount Chip Capacitors, Kemet
- C30, C39 1.0  $\mu$ F, 35 V Tantalum Surface Mount Chip Capacitors, Kemet
- C35, C44 470  $\mu$ F, 63 V Electrolytic Capacitors, Sprague
- Coax1, Coax2 25  $\Omega$ , Semi Rigid Coax, 70 mil OD, 1.05" Long
- Coax3, Coax4 50  $\Omega$ , Semi Rigid Coax, 85 mil OD, 1.05" Long
- L1 5.0 nH, Minispring Inductor, Coilcraft
- L2 8.0 nH, Minispring Inductor, Coilcraft
- L3, L4 5.60 nH, Microspring Inductors, Coilcraft
- R1, R2 1 k $\Omega$ , 1/2 W Fixed Metal Film Resistors, Dale
- R3, R4 270  $\Omega$ , 1/8 W Fixed Film Chip Resistors, Dale
- R5, R6 1.0 k $\Omega$ , 1/8 W Fixed Film Chip Resistors, Dale
- Z1 0.150" x 0.080" Microstrip

- Z2 0.320" x 0.080" Microstrip
- Z4, Z5 1.050" x 0.080" Microstrip
- Z6, Z7 0.120" x 0.080" Microstrip
- Z8, Z9 0.140" x 0.080" Microstrip
- Z10, Z11 0.610" x 0.080" Microstrip
- Z12, Z13 0.135" x 0.080" Microstrip
- Z14, Z15 0.130" x 0.080" Microstrip
- Z16, Z17 0.300" x 0.350" Microstrip
- Z18, Z19 0.150" x 0.500" Microstrip
- Z20, Z21 0.075" x 0.500" Microstrip
- Z22, Z23 0.330" x 0.500" Microstrip
- Z24, Z25 0.100" x 0.550" Microstrip
- Z26, Z27 0.175" x 0.550" Microstrip
- Z28, Z29 0.045" x 0.550" Microstrip
- Z30, Z31 0.190" x 0.325" Microstrip
- Z32, Z33 0.080" x 0.325" Microstrip
- Z34, Z35 0.515" x 0.080" Microstrip
- Z36, Z37 0.020" x 0.080" Microstrip
- Z38, Z39 0.565" x 0.080" Microstrip
- Z40 0.100" x 0.080" Microstrip
- Z41 0.470" x 0.080" Microstrip
- Z42 0.100" x 0.080" Microstrip
- Board Material 0.03" Teflon<sup>®</sup>,  $\epsilon_r = 2.55$  Copper Clad, 2 oz. Cu
- Connectors N-Type Panel Mount, Stripline

Figure 1. 1.93 - 1.99 GHz Broadband Test Circuit Schematic

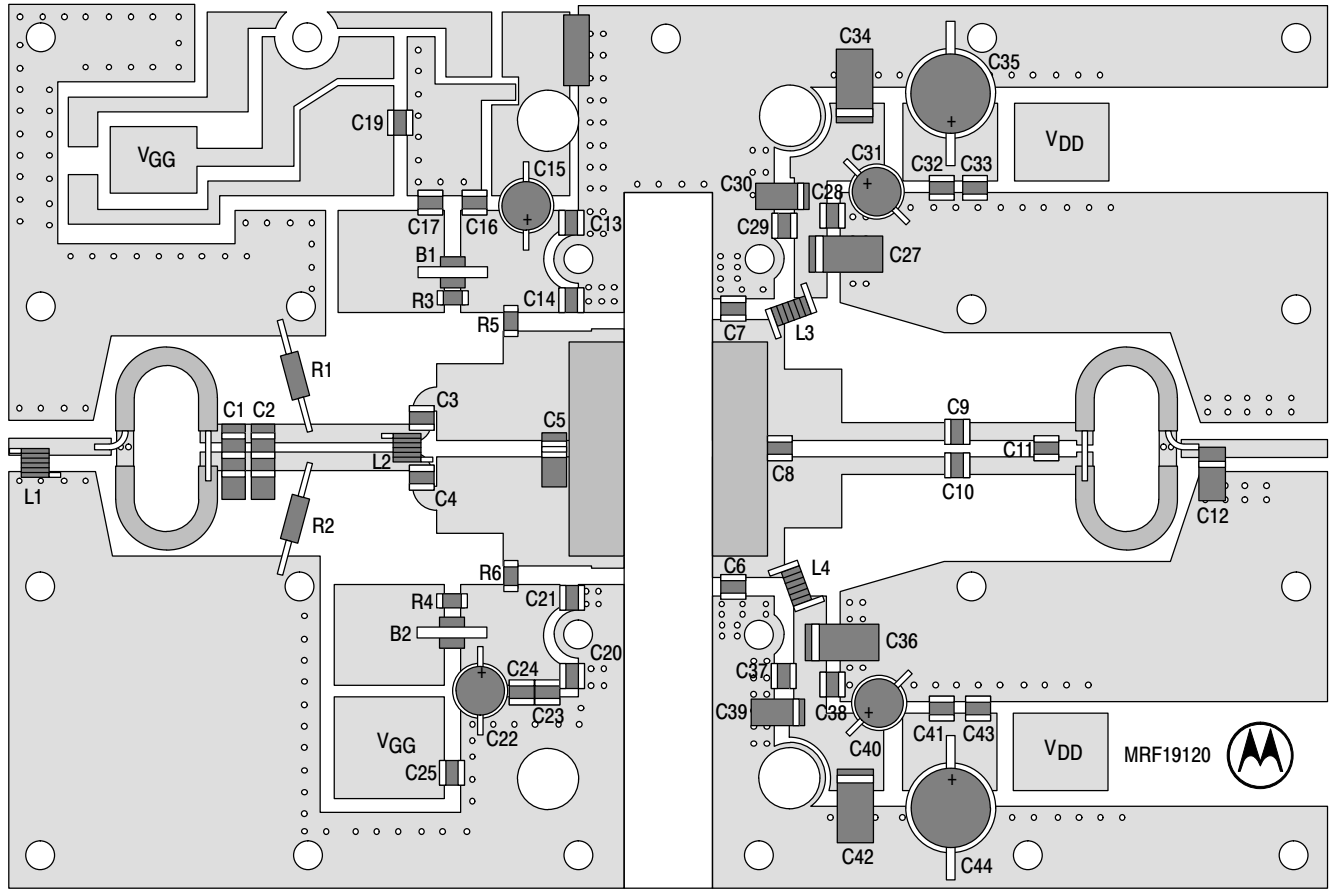

Figure 2. MRF19120 Test Circuit Component Layout

Freescale Semiconductor, Inc.  
ARCHIVE INFORMATION

ARCHIVE INFORMATION

# Freescale Semiconductor, Inc.

## TYPICAL CHARACTERISTICS

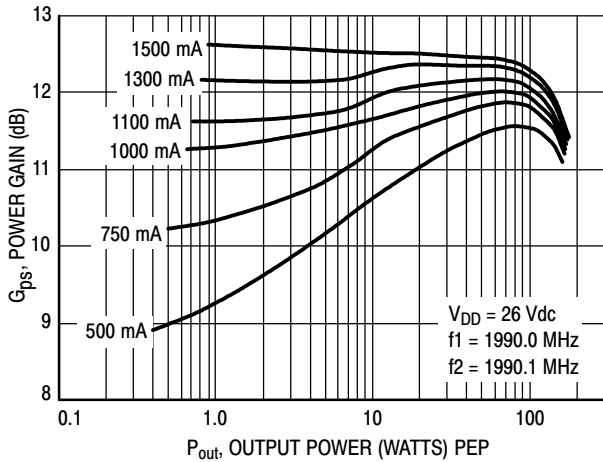

Figure 3. Power Gain versus Output Power

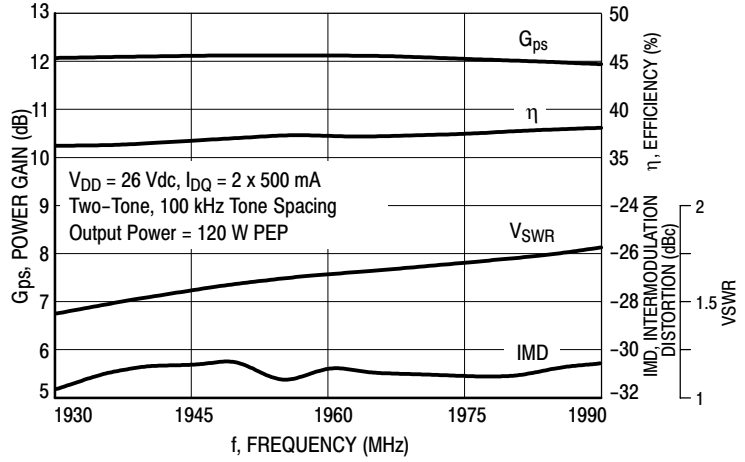

Figure 4. Class AB Broadband Circuit Performance

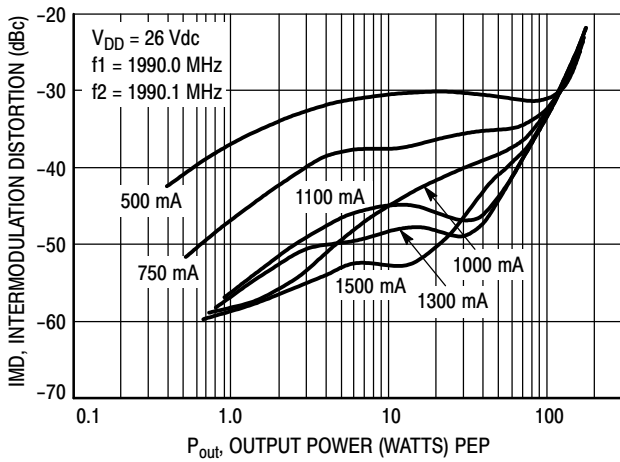

Figure 5. Intermodulation Distortion versus Output Power

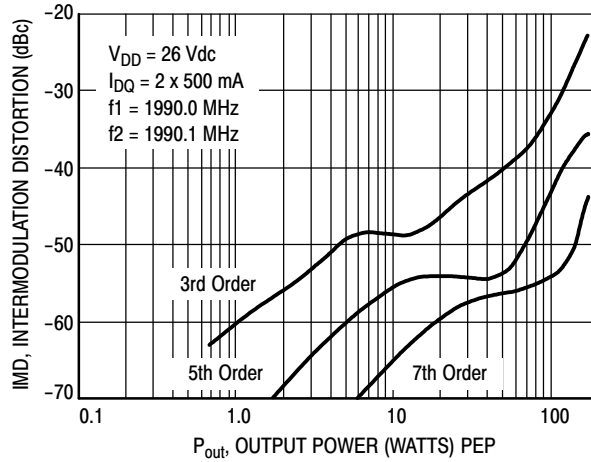

Figure 6. Intermodulation Distortion Products versus Output Power

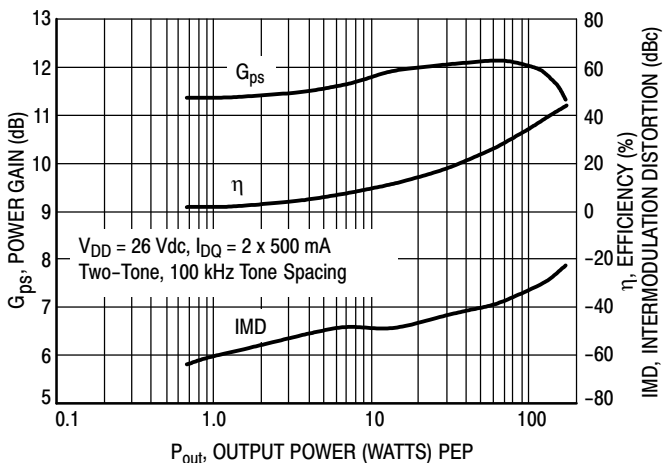

Figure 7. Power Gain, Efficiency, and IMD versus Output Power

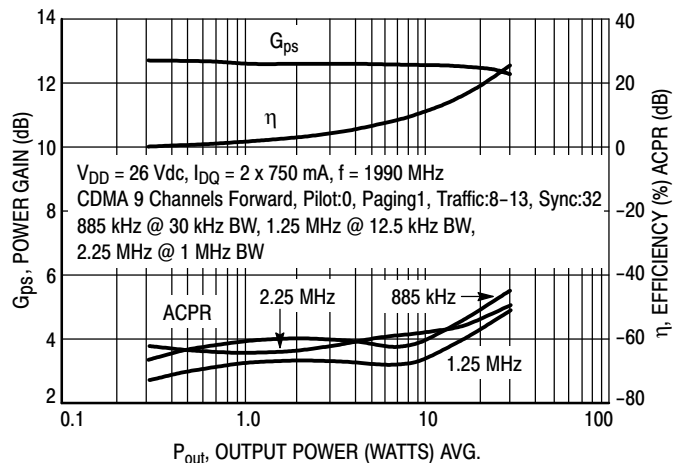
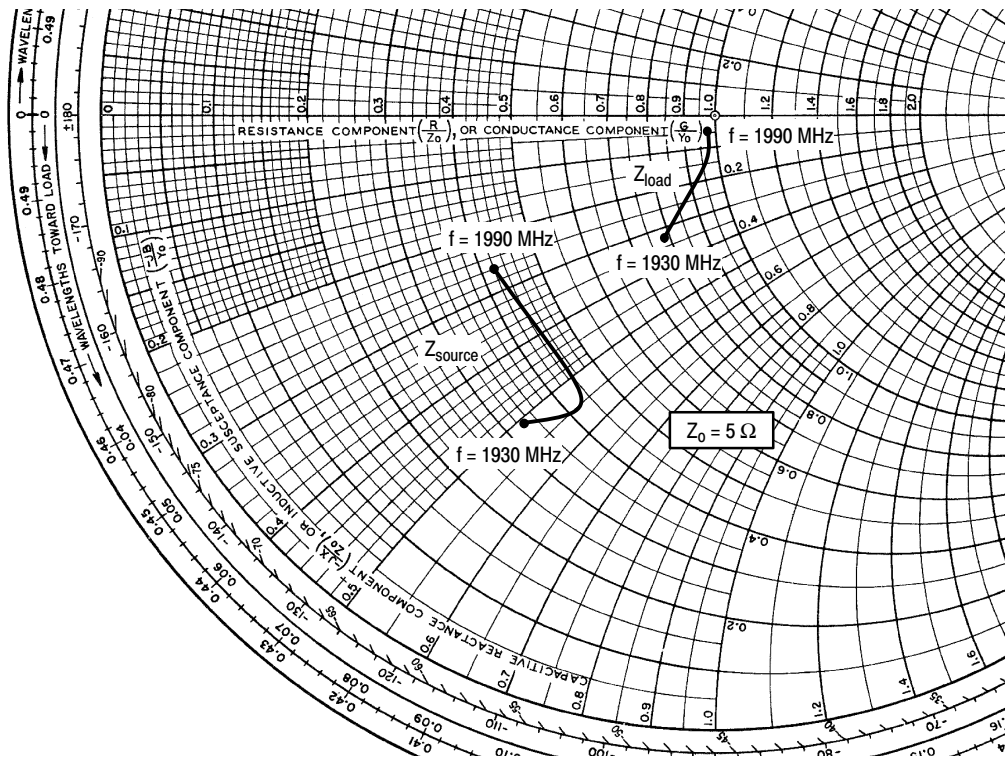

Figure 8. Power Gain, Efficiency, and ACPR versus Output Power

ARCHIVE INFORMATION

ARCHIVE INFORMATION



$V_{DD} = 26 \text{ V}$ ,  $I_{DQ} = 2 \times 500 \text{ mA}$ ,  $P_{out} = 120 \text{ W PEP}$

f MHz	$Z_{source}$ $\Omega$	$Z_{load}$ $\Omega$
1930	$1.64 - j2.6$	$3.9 - j1.7$
1960	$2.10 - j2.8$	$4.8 - j0.8$
1990	$2.10 - j1.4$	$4.9 - j0.3$

$Z_{source}$  = Test circuit impedance as measured from gate to gate, balanced configuration.

$Z_{load}$  = Test circuit impedance as measured from drain to drain, balanced configuration.

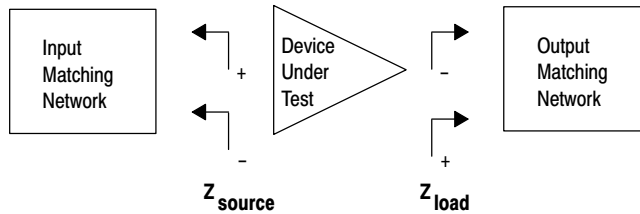
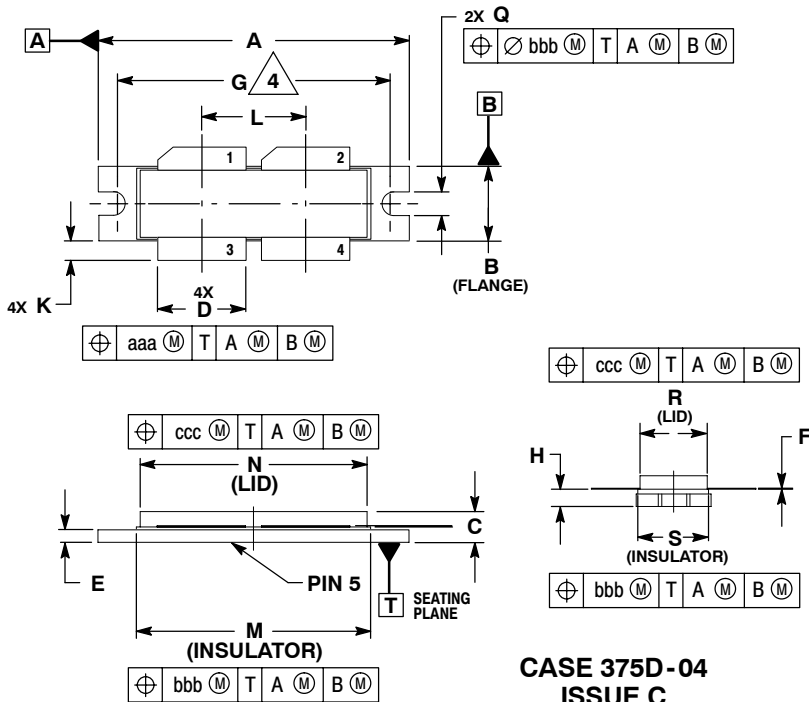

Figure 9. Series Equivalent Input and Output Impedance

# Freescale Semiconductor, Inc.

## PACKAGE DIMENSIONS



### NOTES:

1. INTERPRET DIMENSIONS AND TOLERANCES PER ASME Y14.5M-1994.
2. CONTROLLING DIMENSION: INCH.
3. DIMENSION H IS MEASURED 0.030 (0.762) AWAY FROM PACKAGE BODY.
4. RECOMMENDED BOLT CENTER DIMENSION OF 1.52 (38.61) BASED ON M3 SCREW.

DIM	INCHES		MILLIMETERS	
	MIN	MAX	MIN	MAX
A	1.615	1.625	41.02	41.28
B	0.395	0.405	10.03	10.29
C	0.150	0.200	3.81	5.08
D	0.455	0.465	11.56	11.81
E	0.062	0.066	1.57	1.68
F	0.004	0.007	0.10	0.18
G	1.400 BSC		35.56 BSC	
H	0.079	0.089	2.01	2.26
K	0.117	0.137	2.97	3.48
L	0.540 BSC		13.72 BSC	
M	1.219	1.241	30.96	31.52
N	1.218	1.242	30.94	31.55
Q	0.120	0.130	3.05	3.30
R	0.355	0.365	9.01	9.27
S	0.365	0.375	9.27	9.53
aaa	0.013 REF		0.33 REF	
bbb	0.010 REF		0.25 REF	
ccc	0.020 REF		0.51 REF	

### STYLE 1:

- PIN 1. DRAIN
- DRAIN
- GATE
- GATE
- SOURCE

**CASE 375D-04  
ISSUE C  
NI-1230**

Information in this document is provided solely to enable system and software implementers to use Motorola products. There are no express or implied copyright licenses granted hereunder to design or fabricate any integrated circuits or integrated circuits based on the information in this document.

Motorola reserves the right to make changes without further notice to any products herein. Motorola makes no warranty, representation or guarantee regarding the suitability of its products for any particular purpose, nor does Motorola assume any liability arising out of the application or use of any product or circuit, and specifically disclaims any and all liability, including without limitation consequential or incidental damages. "Typical" parameters that may be provided in Motorola data sheets and/or specifications can and do vary in different applications and actual performance may vary over time. All operating parameters, including "Typicals", must be validated for each customer application by customer's technical experts. Motorola does not convey any license under its patent rights nor the rights of others. Motorola products are not designed, intended, or authorized for use as components in systems intended for surgical implant into the body, or other applications intended to support or sustain life, or for any other application in which the failure of the Motorola product could create a situation where personal injury or death may occur. Should Buyer purchase or use Motorola products for any such unintended or unauthorized application, Buyer shall indemnify and hold Motorola and its officers, employees, subsidiaries, affiliates, and distributors harmless against all claims, costs, damages, and expenses, and reasonable attorney fees arising out of, directly or indirectly, any claim of personal injury or death associated with such unintended or unauthorized use, even if such claim alleges that Motorola was negligent regarding the design or manufacture of the part.

MOTOROLA and the Stylized M Logo are registered in the US Patent and Trademark Office. All other product or service names are the property of their respective owners. Motorola, Inc. is an Equal Opportunity/Affirmative Action Employer.

© Motorola Inc. 2004

### HOW TO REACH US:

**USA/EUROPE/LOCATIONS NOT LISTED:**  
Motorola Literature Distribution  
P.O. Box 5405, Denver, Colorado 80217  
1-800-521-6274 or 480-768-2130

**JAPAN:** Motorola Japan Ltd.; SPS, Technical Information Center,  
3-20-1, Minami-Azabu, Minato-ku, Tokyo 106-8573, Japan  
81-3-3440-3569

**ASIA/PACIFIC:** Motorola Semiconductors H.K. Ltd.; Silicon Harbour Centre,  
2 Dai King Street, Tai Po Industrial Estate, Tai Po, N.T., Hong Kong  
852-26668334

**HOME PAGE:** <http://motorola.com/semiconductors>



For More Information On This Product,  
Go to: [www.freescale.com](http://www.freescale.com)

MRF19120/D