

Freescale Semiconductor

MPX2300DT1
Rev 8, 04/2010

High Volume Pressure Sensor for Disposable Applications

Freescale Semiconductor has developed a low cost, high volume, miniature pressure sensor package which is ideal as a sub-module component or a disposable unit. The unique concept of the Chip Pak allows great flexibility in system design while allowing an economic solution for the designer. This new chip carrier package uses Freescale Semiconductor's unique sensor die with its piezoresistive technology, along with the added feature of on-chip, thin-film temperature compensation and calibration.

NOTE: Freescale Semiconductor is also offering the Chip Pak package in application-specific configurations, which will have an "SPX" prefix, followed by a four-digit number, unique to the specific customer

Features

- Low Cost
- Integrated Temperature Compensation and Calibration
- Ratiometric to Supply Voltage
- Polysulfone Case Material (ISO 10993)
- Provided in Easy-to-Use Tape and Reel

**MPX2300DT1
MPX2301DT1**

**Pressure Sensors
0 to 300 mmHg
(0 to 40 kPa)**

Application Examples

- Medical Diagnostics
- Infusion Pumps
- Blood Pressure Monitors
- Pressure Catheter Applications
- Patient Monitoring

ORDERING INFORMATION

Device Name	Package Options	Case No.	Pressure Type			Device Marking
			Gauge	Differential	Absolute	
MPX2300DT1	Tape and Reel	423A		•		Date Code, Lot ID
MPX2301DT1	Tape and Reel	423A		•		Date Code, Lot ID

CHIP PAK PACKAGE

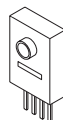

**MPX2300DT1/MPX2301DT1
CASE 423A-03**

NOTE: The die and wire bonds are exposed on the front side of the Chip Pak (pressure is applied to the backside of the device). Front side die and wire protection must be provided in the customer's housing. Use caution when handling the devices during all processes.

The MPX2300DT1/MPX2301DT1 Pressure Sensors have been designed for medical usage by combining the performance of Freescale's shear stress pressure sensor design and the use of biomedically approved materials. Materials with a proven history in medical situations have been chosen to provide a sensor that can be used with confidence in applications, such as invasive blood pressure monitoring. It can be sterilized using ethylene oxide. The portions of the pressure sensor that are required to be biomedically approved are the rigid housing and the gel coating.

The rigid housing is molded from a white, medical grade polysulfone that has passed extensive biological testing including: 10993-5:1999, 10993-10:2002, and 10993-11:1993.

A silicone dielectric gel covers the silicon piezoresistive sensing element. The gel is a nontoxic, nonallergenic elastomer system which meets all USP XX Biological Testing Class V requirements. The properties of the gel allow it to transmit pressure uniformly to the diaphragm surface, while isolating the internal electrical connections from the corrosive effects of fluids, such as saline solution. The gel provides electrical isolation sufficient to withstand defibrillation testing, as specified in the proposed Association for the Advancement of Medical Instrumentation (AAMI) Standard for blood pressure transducers. A biomedically approved opaque filler in the gel prevents bright operating room lights from affecting the performance of the sensor. The MPX2301DT1 is a reduced gel option.

Maximum Ratings

Table 1. Maximum Ratings⁽¹⁾

Rating	Symbol	Value	Unit
Maximum Pressure (Backside)	P_{max}	125	PSI
Storage Temperature	T_{stg}	-25 to +85	°C
Operating Temperature	T_A	+15 to +40	°C

1. Exposure beyond the specified limits may cause permanent damage or degradation to the device.

Operating Characteristics

Table 2. Operating Characteristics ($V_S = 6$ Vdc, $T_A = 25$ °C unless otherwise noted)

Characteristics	Symbol	Min	Typ	Max	Unit
Pressure Range	P_{OP}	0	—	300	mmHg
Supply Voltage ⁽¹⁾	V_S	—	6.0	10	Vdc
Supply Current	I_o	—	1.0	—	mAdc
Zero Pressure Offset	V_{off}	-0.75	—	0.75	mV
Sensitivity	—	4.95	5.0	5.05	μ V/V/mmHg
Full Scale Span ⁽²⁾	V_{FSS}	2.976	3.006	3.036	mV
Linearity + Hysteresis ⁽³⁾	—	-1.5	—	1.5	% V_{FSS}
Accuracy ⁽⁹⁾ $V_S = 6$ V, $P = 101$ to 200 mmHg	—	-1.5	—	1.5	%
Accuracy ⁽⁹⁾ $V_S = 6$ V, $P = 201$ to 300 mmHg	—	-3.0	—	3.0	%
Temperature Effect on Sensitivity	TCS	-0.1	—	+0.1	%/°C
Temperature Effect on Full Scale Span ⁽⁴⁾	TCV_{FSS}	-0.1	—	+0.1	%/°C
Temperature Effect on Offset ⁽⁵⁾	TCV_{off}	-9.0	—	+9.0	μ V/°C
Input Impedance	Z_{in}	1800	—	4500	Ω
Output Impedance	Z_{out}	270	—	330	Ω
R_{CAL} (150 k Ω) ⁽⁶⁾	R_{CAL}	97	100	103	mmHg
Response Time ⁽⁷⁾ (10% to 90%)	t_R	—	1.0	—	ms
Temperature Error Band	—	0	—	85	°C
Stability ⁽⁸⁾	—	—	± 0.5	—	% V_{FSS}

1. Recommended voltage supply: 6 V \pm 0.2 V, regulated. Sensor output is ratiometric to the voltage supply. Supply voltages above +10 V may induce additional error due to device self-heating.
2. Measured at 6.0 Vdc excitation for 100 mmHg pressure differential. V_{FSS} and FSS are like terms representing the algebraic difference between full scale output and zero pressure offset.
3. Maximum deviation from end-point straight line fit at 0 and 200 mmHg.
4. Slope of end-point straight line fit to full scale span at 15°C and +40°C relative to +25°C.
5. Slope of end-point straight line fit to zero pressure offset at 15°C and +40°C relative to +25°C.
6. Offset measurement with respect to the measured sensitivity when a 150 k resistor is connected to V_S and S+ output.
7. For a 0 to 300 mmHg pressure step change.
8. Stability is defined as the maximum difference in output at any pressure within P_{OP} and temperature within +10°C to +85°C after:
 - 1000 temperature cycles, -40°C to +125°C.
 - 1.5 million pressure cycles, 0 to 300 mmHg.

PACKAGE DIMENSIONS

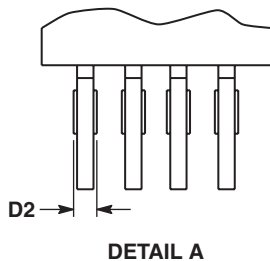
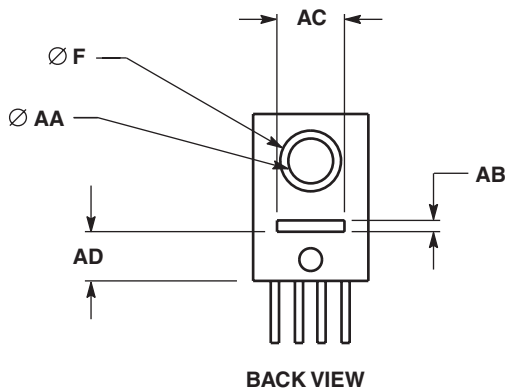
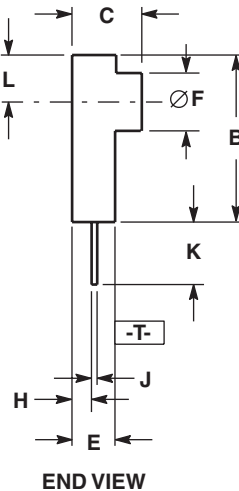
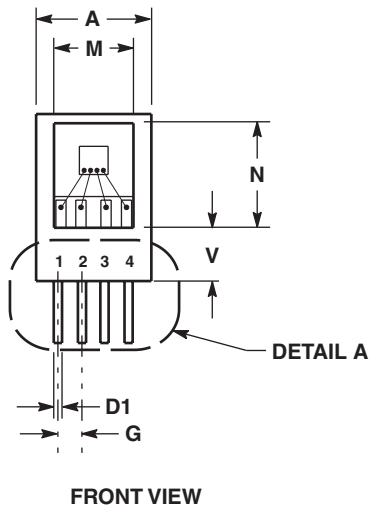

- NOTES:
1. DIMENSIONING AND TOLERANCING PER ANSI Y14.5M, 1982.
 2. CONTROLLING DIMENSION: INCH.

DIM	INCHES		MILLIMETERS	
	MIN	MAX	MIN	MAX
A	0.240	0.260	6.10	6.60
B	0.350	0.370	8.89	9.40
C	0.140	0.150	3.56	3.81
D1	0.012	0.020	0.30	0.51
D2	0.014	0.022	0.36	0.56
E	0.088	0.102	2.24	2.59
F	0.123	0.128	3.12	3.25
G	0.045	0.055	1.14	1.40
H	0.037	0.047	0.94	1.19
J	0.007	0.011	0.18	0.28
K	0.120	0.140	3.05	3.56
L	0.095	0.105	2.41	2.67
M	0.165	0.175	4.19	4.45
N	0.223	0.239	5.66	6.07
V	0.105	0.115	2.67	2.92
AA	0.095	0.107	2.41	2.72
AB	0.015	0.035	0.38	0.89
AC	0.120	0.175	3.05	4.45
AD	0.100	0.115	2.54	2.92

- STYLE 1:
 PIN 1. V_{cc}
 2. +OUT
 3. -OUT
 4. GROUND

CASE 423A-03
 ISSUE C
 CHIP PAK PACKAGE

How to Reach Us:

Home Page:

www.freescale.com

Web Support:

<http://www.freescale.com/support>

USA/Europe or Locations Not Listed:

Freescale Semiconductor, Inc.
Technical Information Center, EL516
2100 East Elliot Road
Tempe, Arizona 85284
1-800-521-6274 or +1-480-768-2130
www.freescale.com/support

Europe, Middle East, and Africa:

Freescale Halbleiter Deutschland GmbH
Technical Information Center
Schatzbogen 7
81829 Muenchen, Germany
+44 1296 380 456 (English)
+46 8 52200080 (English)
+49 89 92103 559 (German)
+33 1 69 35 48 48 (French)
www.freescale.com/support

Japan:

Freescale Semiconductor Japan Ltd.
Headquarters
ARCO Tower 15F
1-8-1, Shimo-Meguro, Meguro-ku,
Tokyo 153-0064
Japan
0120 191014 or +81 3 5437 9125
support.japan@freescale.com

Asia/Pacific:

Freescale Semiconductor China Ltd.
Exchange Building 23F
No. 118 Jianguo Road
Chaoyang District
Beijing 100022
China
+86 010 5879 8000
support.asia@freescale.com

For Literature Requests Only:

Freescale Semiconductor Literature Distribution Center
1-800-441-2447 or +1-303-675-2140
Fax: +1-303-675-2150
LDCForFreescaleSemiconductor@hibbertgroup.com

Information in this document is provided solely to enable system and software implementers to use Freescale Semiconductor products. There are no express or implied copyright licenses granted hereunder to design or fabricate any integrated circuits or integrated circuits based on the information in this document.

Freescale Semiconductor reserves the right to make changes without further notice to any products herein. Freescale Semiconductor makes no warranty, representation or guarantee regarding the suitability of its products for any particular purpose, nor does Freescale Semiconductor assume any liability arising out of the application or use of any product or circuit, and specifically disclaims any and all liability, including without limitation consequential or incidental damages. "Typical" parameters that may be provided in Freescale Semiconductor data sheets and/or specifications can and do vary in different applications and actual performance may vary over time. All operating parameters, including "Typicals", must be validated for each customer application by customer's technical experts. Freescale Semiconductor does not convey any license under its patent rights nor the rights of others. Freescale Semiconductor products are not designed, intended, or authorized for use as components in systems intended for surgical implant into the body, or other applications intended to support or sustain life, or for any other application in which the failure of the Freescale Semiconductor product could create a situation where personal injury or death may occur. Should Buyer purchase or use Freescale Semiconductor products for any such unintended or unauthorized application, Buyer shall indemnify and hold Freescale Semiconductor and its officers, employees, subsidiaries, affiliates, and distributors harmless against all claims, costs, damages, and expenses, and reasonable attorney fees arising out of, directly or indirectly, any claim of personal injury or death associated with such unintended or unauthorized use, even if such claim alleges that Freescale Semiconductor was negligent regarding the design or manufacture of the part.

Freescale and the Freescale logo are trademarks of Freescale Semiconductor, Inc., Reg. U.S. Pat. & Tm. Off. All other product or service names are the property of their respective owners.

© Freescale Semiconductor, Inc. 2010. All rights reserved.