

74F1071

18-Bit Undershoot/Overshoot Clamp and ESD Protection Device

Features

- 18-bit array structure in 20-pin package
- FAST® Bipolar voltage clamping action
- Dual center pin grounds for min inductance
- Robust design for ESD protection
- Low input capacitance
- Optimum voltage clamping for 5V CMOS/TTL applications

General Description

The 74F1071 is an 18-bit undershoot/overshoot clamp which is designed to limit bus voltages and also to protect more sensitive devices from electrical overstress due to electrostatic discharge (ESD). The inputs of the device aggressively clamp voltage excursions nominally at 0.5V below and 7V above ground.

Ordering Information

Order Number	Package Number	Package Description
74F1071SC	M20B	20-Lead Small Outline Integrated Circuit (SOIC), JEDEC MS-013, 0.300" Wide
74F1071MSA	MSA20	20-Lead Shrink Small Outline Package (SSOP), JEDEC MO-150, 5.3mm Wide
74F1071MTC	MTC20	20-Lead Thin Shrink Small Outline Package (TSSOP), JEDEC MO-153, 4.4mm Wide

Device also available in Tape and Reel. Specify by appending suffix letter "X" to the ordering number.

 All packages are lead free per JEDEC: J-STD-020B standard.

Connection Diagram

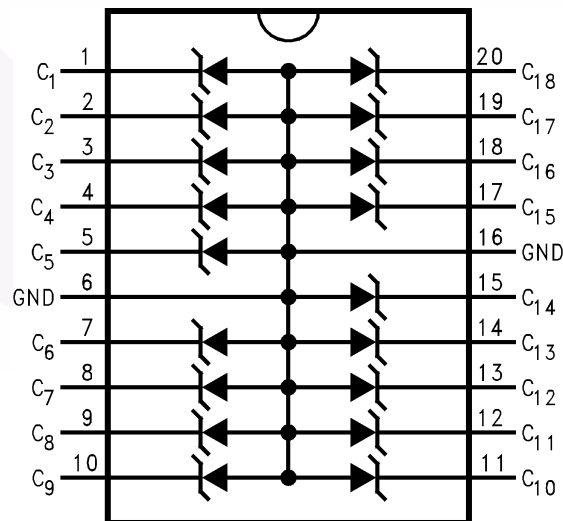

Note: Simplified Component Representation

Absolute Maximum Ratings

Stresses exceeding the absolute maximum ratings may damage the device. The device may not function or be operable above the recommended operating conditions and stressing the parts to these levels is not recommended. In addition, extended exposure to stresses above the recommended operating conditions may affect device reliability. The absolute maximum ratings are stress ratings only.

Symbol	Parameter	Rating
T_{STG}	Storage Temperature	-65°C to +150°C
T_A	Ambient Temperature Under Bias	-65°C to +125°C
T_J	Junction Temperature Under Bias	-65°C to +150°C
V_I	Input Voltage ⁽¹⁾	-0.5V to +6V
I_I	Input Current ⁽¹⁾	-200mA to +50mA
	ESD ⁽²⁾	
	Human Body Model (MIL-STD-883D method 3015.7)	±10kV
	IEC 801-2	±6kV
	Machine Model (EIAJIC-121-1981)	±2kV
	DC Latchup Source Current (JEDEC Method 17)	±500mA
	Package Power Dissipation @ +70°C SOIC Package	800mW

Notes:

- Voltage ratings may be exceeded if current ratings and junction temperature and power consumption ratings are not exceeded.
- ESD Rating for Direct contact discharge using ESD Simulation Tester. Higher rating may be realized in the actual application.

Recommended Operating Conditions

The Recommended Operating Conditions table defines the conditions for actual device operation. Recommended operating conditions are specified to ensure optimal performance to the datasheet specifications. Fairchild does not recommend exceeding them or designing to absolute maximum ratings.

Symbol	Parameter	Rating
T_A	Free Air Ambient Temperature	0°C to +70°C
V_Z	Reverse Bias Voltage	0V to 5.25 V_{DC}
θ_{JA}	Thermal Resistance (in Free Air)	
	SOIC Package	100°C/W
	SSOP Package	110°C/W

DC Electrical Characteristics

Symbol	Parameter	Conditions	T _A = +25°C			T _A = 0°C to +70°C		Units
			Min.	Typ.	Max.	Min.	Max.	
I _{IH}	Input HIGH Current	V _{IN} = 5.25V; Untested Input @ GND		1.5	10		50	μA
		V _{IN} = 5.5V; Untested Input @ GND		3	20		100	
V _Z	Reverse Voltage	I _Z = 1mA; Untested Inputs @ GND	6.6	6.9	7.2	5.9	7.7	V
		I _Z = 50mA; Untested Inputs @ GND		7.1	7.5		8.0	
V _F	Forward Voltage	I _F = -18mA; Untested Inputs @ 5V	-0.3	-0.6	-0.9	-0.3	-0.9	V
		I _F = -200mA; Untested Inputs @ 5V	-0.5	-1.1	-1.5	-0.5	-1.5	
I _{CT}	Adjacent Input Crosstalk				3			%
C _{IN}	Input Capacitance (small signal @ 1MHz)	V _{BIAS} = 0 V _{DC}		25				pF
		V _{BIAS} = 5 V _{DC}		13				

DC Electrical Characteristics

Typical Forward and Reverse V/I Characteristics

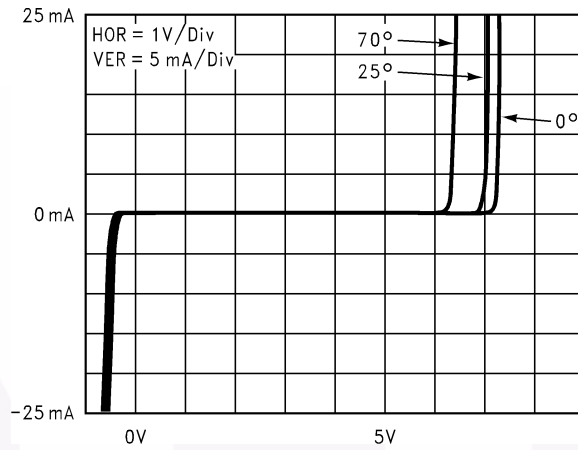

Typical Reverse Conduction Characteristics

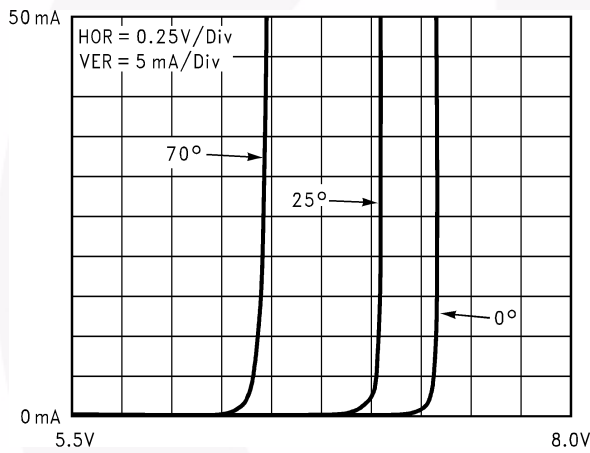

Typical Forward Conduction Characteristics

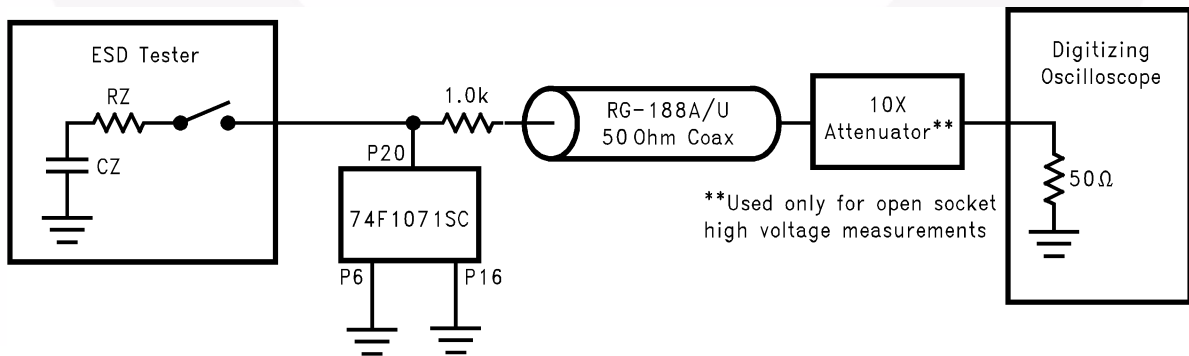
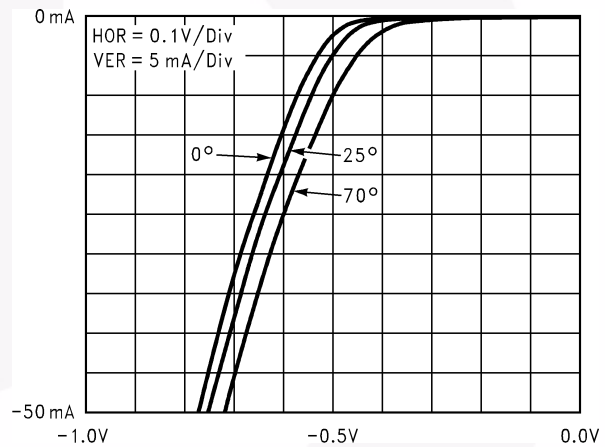

ESD Network	CZ	RZ
Human Body Model	100pF	1500Ω
IEC 801-2	150pF	330Ω

Simulated ESD Voltage Clamping Test Circuit

DC Electrical Characteristics (Continued)

**Unclamped +1kV ESD Voltage Waveform
(IEC801-2 Network)**

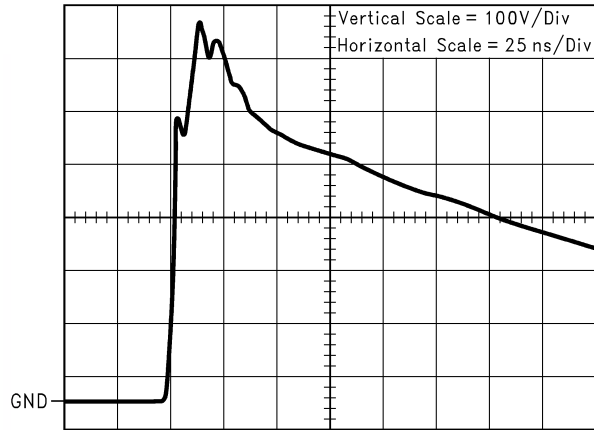

**Clamped +1kV ESD Voltage Waveform
(IEC801-2 Network)**

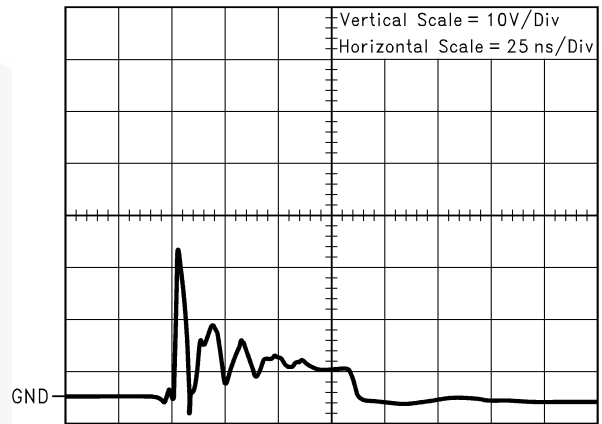

**Unclamped -1kV ESD Voltage Waveform
(IEC801-2 Network)**

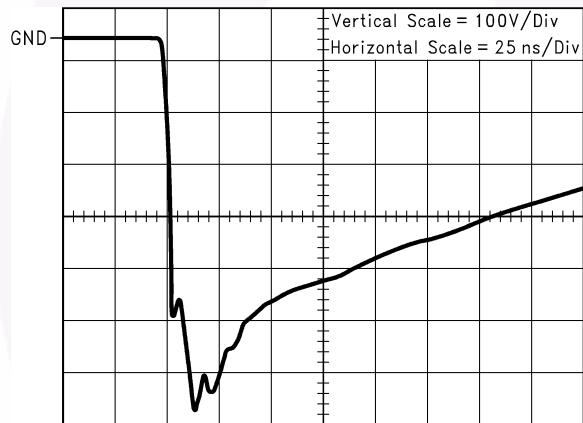

**Clamped -1kV ESD Voltage Waveform
(IEC801-2 Network)**

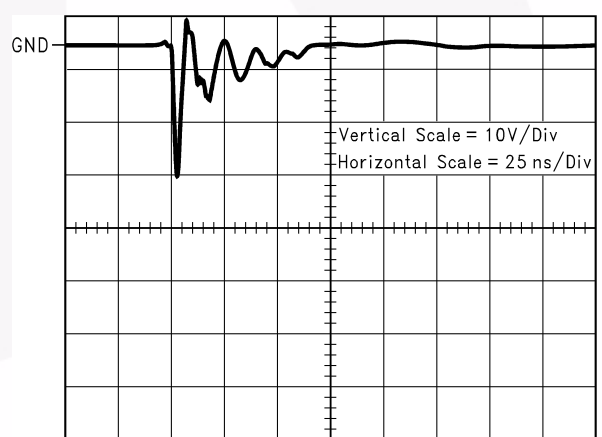

Typical Application

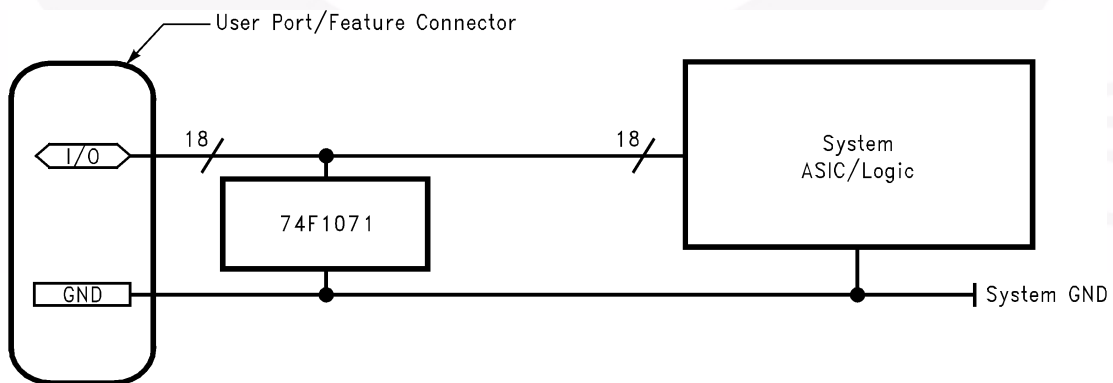

74F1071 ESD Protection of ASIC on User Port

Physical Dimensions

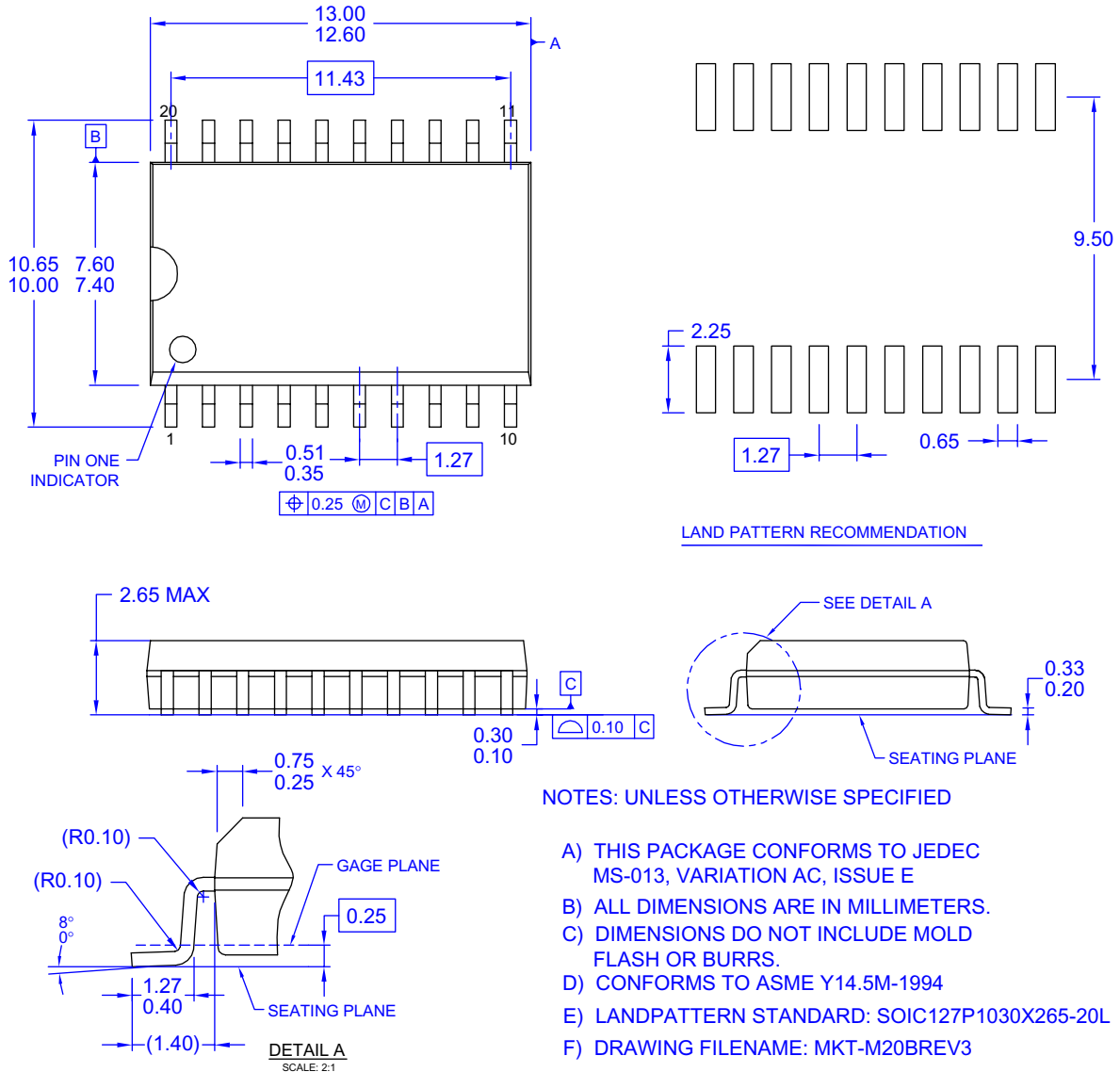

Figure 1. 20-Lead Small Outline Integrated Circuit (SOIC), JEDEC MS-013, 0.300" Wide

Package drawings are provided as a service to customers considering Fairchild components. Drawings may change in any manner without notice. Please note the revision and/or date on the drawing and contact a Fairchild Semiconductor representative to verify or obtain the most recent revision. Package specifications do not expand the terms of Fairchild's worldwide terms and conditions, specifically the warranty therein, which covers Fairchild products.

Always visit Fairchild Semiconductor's online packaging area for the most recent package drawings:

<http://www.fairchildsemi.com/packaging/>

Physical Dimensions (Continued)

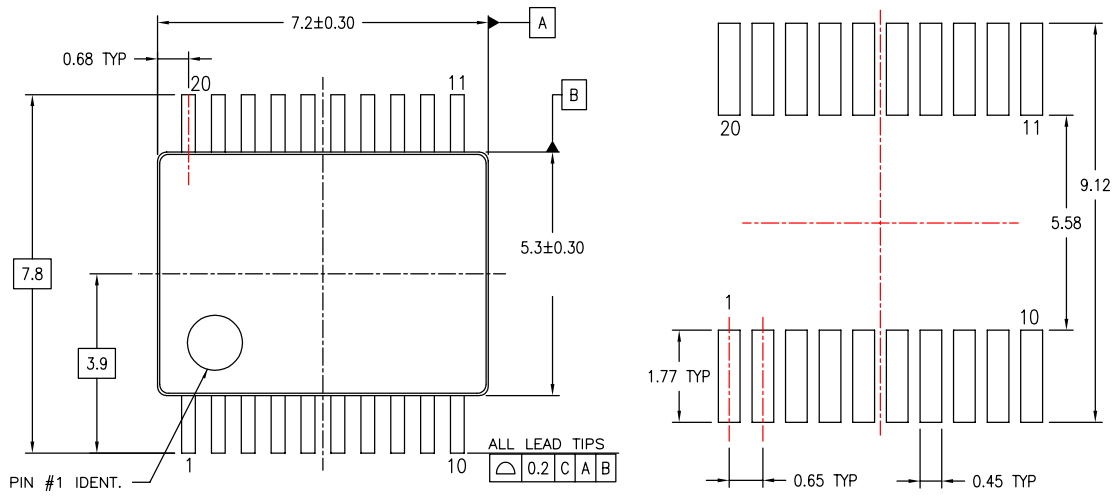

LAND PATTERN RECOMMENDATIONS

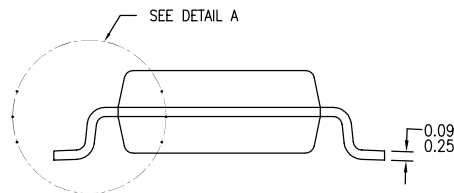
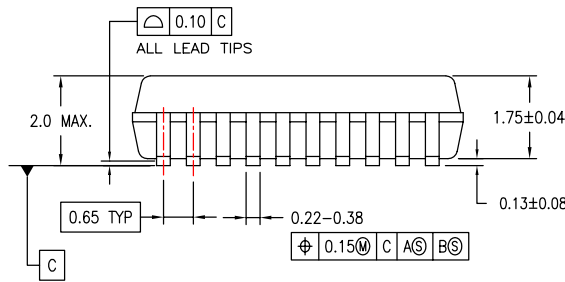

DIMENSIONS ARE IN MILLIMETERS

NOTES:

- A. CONFORMS TO JEDEC REGISTRATION MO-150, VARIATION AE, DATE 1/94.
- B. DIMENSIONS ARE IN MILLIMETERS.
- C. DIMENSIONS ARE EXCLUSIVE OF BURRS, MOLD FLASH, AND TIE BAR EXTRUSIONS.
- D. DIMENSIONS AND TOLERANCES PER ASME Y14.5M - 1994.

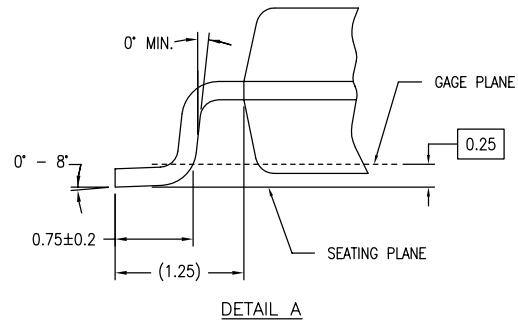

MSA20REV B

Figure 2. 20-Lead Shrink Small Outline Package (SSOP), JEDEC MO-150, 5.3mm Wide

Package drawings are provided as a service to customers considering Fairchild components. Drawings may change in any manner without notice. Please note the revision and/or date on the drawing and contact a Fairchild Semiconductor representative to verify or obtain the most recent revision. Package specifications do not expand the terms of Fairchild's worldwide terms and conditions, specifically the warranty therein, which covers Fairchild products.

Always visit Fairchild Semiconductor's online packaging area for the most recent package drawings:

<http://www.fairchildsemi.com/packaging/>

Physical Dimensions (Continued)

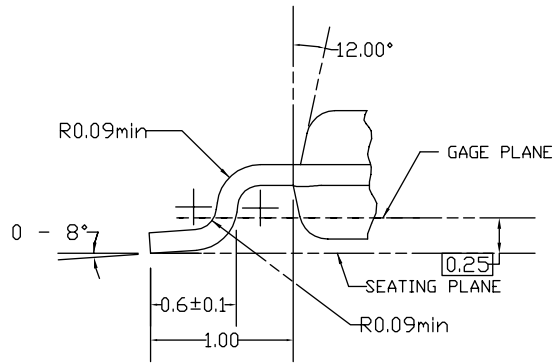
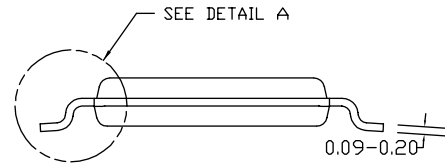
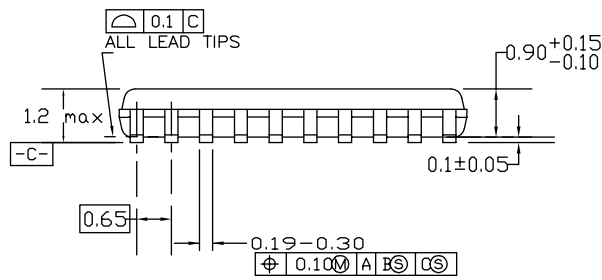
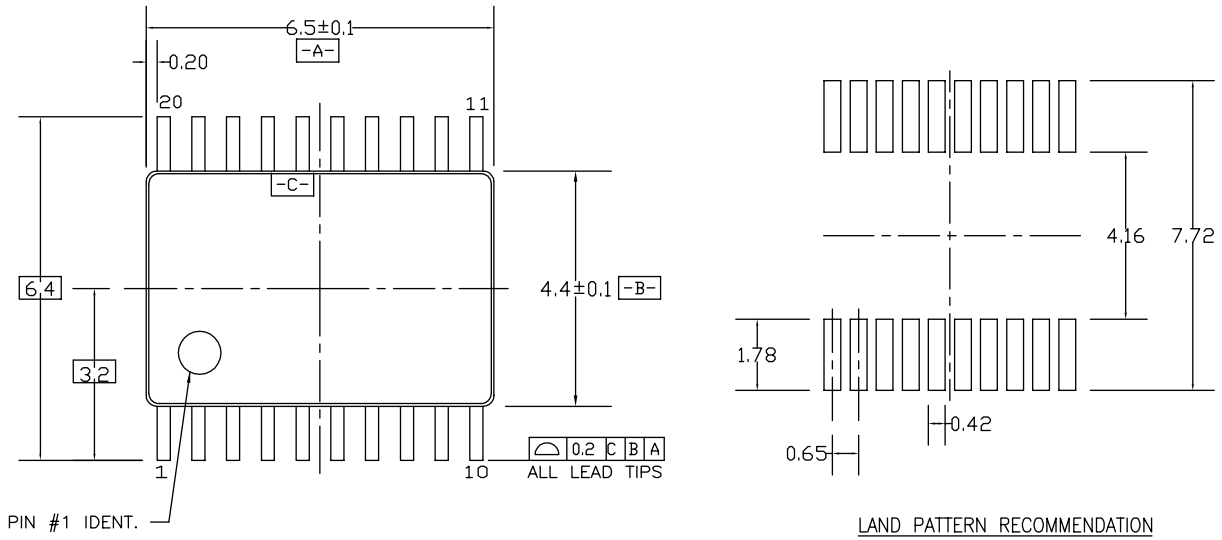

DIMENSIONS ARE IN MILLIMETERS

NOTES:

- A. CONFORMS TO JEDEC REGISTRATION MO-153, VARIATION AC, REF NOTE 6, DATE 7/93.
- B. DIMENSIONS ARE IN MILLIMETERS.
- C. DIMENSIONS ARE EXCLUSIVE OF BURRS, MOLDS FLASH, AND TIE BAR EXTRUSIONS.
- D. DIMENSIONS AND TOLERANCES PER ANSI Y14.5M, 1982.

MTC20REV D1

Figure 3. 20-Lead Thin Shrink Small Outline Package (TSSOP), JEDEC MO-153, 4.4mm Wide

Package drawings are provided as a service to customers considering Fairchild components. Drawings may change in any manner without notice. Please note the revision and/or date on the drawing and contact a Fairchild Semiconductor representative to verify or obtain the most recent revision. Package specifications do not expand the terms of Fairchild's worldwide terms and conditions, specifically the warranty therein, which covers Fairchild products.



Always visit Fairchild Semiconductor's online packaging area for the most recent package drawings:

<http://www.fairchildsemi.com/packaging/>



TRADEMARKS

The following includes registered and unregistered trademarks and service marks, owned by Fairchild Semiconductor and/or its global subsidiaries, and is not intended to be an exhaustive list of all such trademarks.

- | | | | |
|---|------------------------|----------------------------|----------------------|
| ACEx® | FPST™ | PDP-SPM™ | SyncFET™ |
| Build it Now™ | FRFET® | Power220® | SYSTEM GENERAL® |
| CorePLUS™ | Global Power Resource™ | Power247® | The Power Franchise® |
| CROSSVOLT™ | Green FPS™ | POWEREDGE® | the power® |
| CTL™ | Green FPS™ e-Series™ | Power-SPM™ | franchise |
| Current Transfer Logic™ | GTO™ | PowerTrench® | TinyBoost™ |
| EcoSPARK® | i-Lo™ | Programmable Active Droop™ | TinyBuck™ |
| EZSWITCH™ * | IntelliMAX™ | QFET® | TinyLogic® |
|  ™ | ISOPLANAR™ | QST™ | TINYOPTO™ |
|  ™ | MegaBuck™ | QT Optoelectronics™ | TinyPower™ |
| Fairchild® | MICROCOUPLER™ | Quiet Series™ | TinyPWM™ |
| Fairchild Semiconductor® | MicroFET™ | RapidConfigure™ | TinyWire™ |
| FACT Quiet Series™ | MicroPak™ | SMART START™ | SerDes™ |
| FACT® | MillerDrive™ | SPM® | UHC® |
| FAST® | Motion-SPM™ | STEALTH™ | Ultra FRFET™ |
| FastvCore™ | OPTOLOGIC® | SuperFET™ | UniFET™ |
| FlashWriter® * | OPTOPLANAR® | SuperSOT™-3 | VCX™ |
| | | SuperSOT™-6 | |
| | | SuperSOT™-8 | |

* EZSWITCH™ and FlashWriter® are trademarks of System General Corporation, used under license by Fairchild Semiconductor.

DISCLAIMER

FAIRCHILD SEMICONDUCTOR RESERVES THE RIGHT TO MAKE CHANGES WITHOUT FURTHER NOTICE TO ANY PRODUCTS HEREIN TO IMPROVE RELIABILITY, FUNCTION, OR DESIGN. FAIRCHILD DOES NOT ASSUME ANY LIABILITY ARISING OUT OF THE APPLICATION OR USE OF ANY PRODUCT OR CIRCUIT DESCRIBED HEREIN; NEITHER DOES IT CONVEY ANY LICENSE UNDER ITS PATENT RIGHTS, NOR THE RIGHTS OF OTHERS. THESE SPECIFICATIONS DO NOT EXPAND THE TERMS OF FAIRCHILD'S WORLDWIDE TERMS AND CONDITIONS, SPECIFICALLY THE WARRANTY THEREIN, WHICH COVERS THESE PRODUCTS.

LIFE SUPPORT POLICY

FAIRCHILD'S PRODUCTS ARE NOT AUTHORIZED FOR USE AS CRITICAL COMPONENTS IN LIFE SUPPORT DEVICES OR SYSTEMS WITHOUT THE EXPRESS WRITTEN APPROVAL OF FAIRCHILD SEMICONDUCTOR CORPORATION.

As used herein:

- Life support devices or systems are devices or systems which, (a) are intended for surgical implant into the body or (b) support or sustain life, and (c) whose failure to perform when properly used in accordance with instructions for use provided in the labeling, can be reasonably expected to result in a significant injury of the user.
- A critical component in any component of a life support, device, or system whose failure to perform can be reasonably expected to cause the failure of the life support device or system, or to affect its safety or effectiveness.

PRODUCT STATUS DEFINITIONS

Definition of Terms

Datasheet Identification	Product Status	Definition
Advance Information	Formative or In Design	This datasheet contains the design specifications for product development. Specifications may change in any manner without notice.
Preliminary	First Production	This datasheet contains preliminary data; supplementary data will be published at a later date. Fairchild Semiconductor reserves the right to make changes at any time without notice to improve design.
No Identification Needed	Full Production	This datasheet contains final specifications. Fairchild Semiconductor reserves the right to make changes at any time without notice to improve the design.
Obsolete	Not In Production	This datasheet contains specifications on a product that has been discontinued by Fairchild Semiconductor. The datasheet is printed for reference information only.

Rev. I32