

Low Power CMOS Photoelectric Smoke Detector IC

The MC146012 is an advanced smoke detector component containing sophisticated very-low power analog and digital circuitry. The IC, when used with an infrared photoelectric chamber and a small number of external components, will detect smoke by sensing scattered light from smoke particles. When detection occurs, a pulsating alarm is sounded via on-chip push-pull drivers and an external piezoelectric transducer.

The MC146012 provides both audible and visual alarms. Upon sensing a normal smoke level, both alarms will be activated. It is possible to mute the audible alarm for approximately eight minutes through the Integrated Mute Function (IMF), although the LED will continue to flash at a high rate. This feature is resettable through a pushbutton test. The IMF feature will be overridden by remote smoke, high smoke level, timeout or reset.

The Alarm memory feature will allow for identification of an alarming detector. Through a pushbutton test, the LED will flash rapidly if there was a previous alarm condition detected at the unit.

The variable-gain photo amplifier allows direct interface to IR detector (photodiode). The gain settings are determined by external capacitors and compensation resistors. A two stage speed-up is incorporated into the smoke monitor to minimize time and help reduce false triggering. Further reduction of false triggering is also addressed with the double sample chamber sensitivity and double I/O sample.

Features

- Integrated Mute Function (IMF) to Temporarily Disable Horn
- Alarm Memory to Help Identify Alarming Unit
- Speed-Up Sampling Rate After First Detection of Smoke
- Double Sample for Degraded Chamber Sensitivity Monitor
- Digital Noise Filter on the I/O Pin
- Power-Up and Power-Down RESET
- Low-Battery Trip Point Set Externally
- Temporal Horn Pattern
- Operating Temperature: -10 to 75°C
- Operating Voltage Range: 6.0 to 12 V
- Average Supply Current: 6.5 μ A

ORDERING INFORMATION

| Device | Temp. Range | Package |
|----------------|-------------|--------------|
| MC146012ED | -10 to 75°C | Plastic Dip |
| MCZ146012EG/R2 | | SOIC Package |

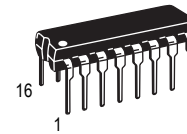
MC146012**LOW POWER CMOS
PHOTOELECTRIC SMOKE
DETECTOR IC**

**ED SUFFIX
PLASTIC DIP
98ASB42431B**

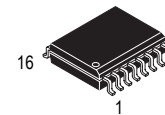

**EG SUFFIX
SOIC PACKAGE
98ASB42567B**

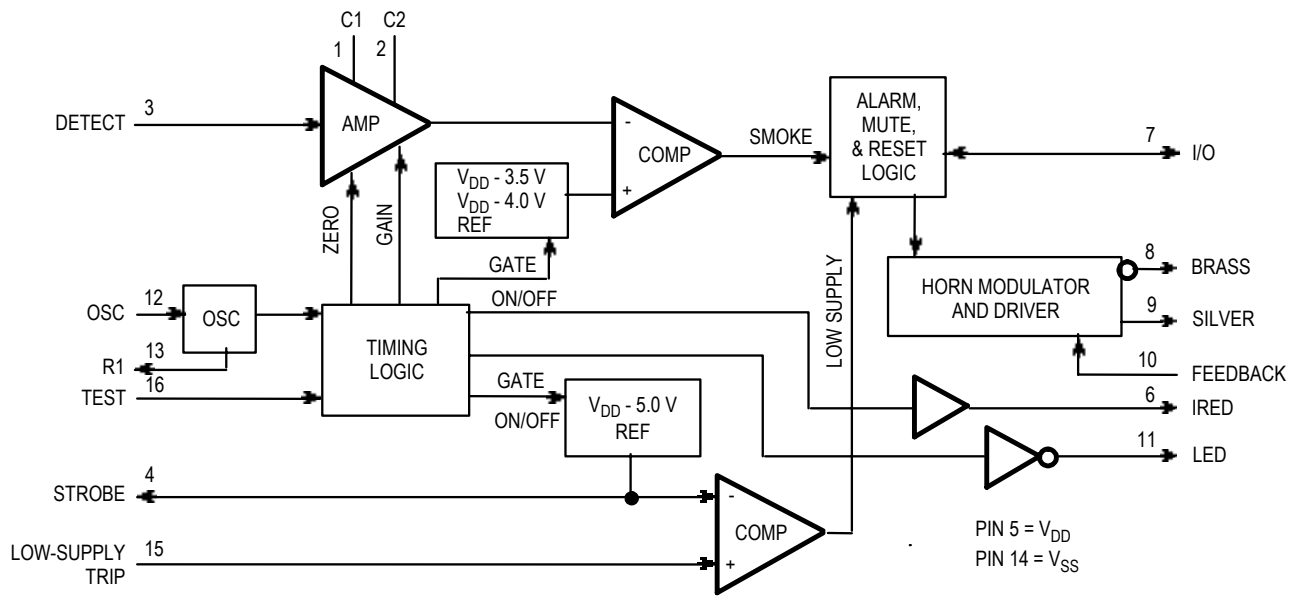

Figure 1. Block Diagram

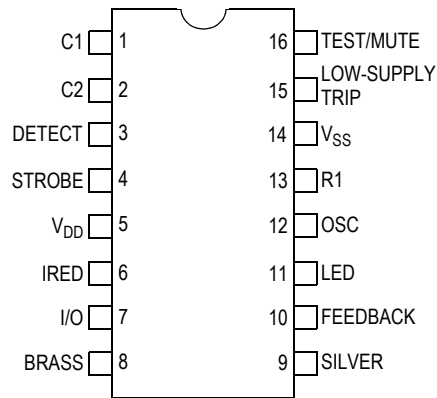

Figure 2. Pin Assignment (16-Pin DIP)

Table 1. Maximum Ratings⁽¹⁾ (Voltages Referenced to V_{SS})

| Symbol | Parameter | Value | Unit |
|-----------|---|---|------|
| V_{DD} | DC Supply Voltage | -0.5 to +12 | V |
| V_{IN} | DC Input Voltage C1, C2, Detect Osc, Low-Supply Trip I/O Feedback Test | -0.25 to $V_{DD} + 0.25$ -0.25 to $V_{DD} + 0.25$ -0.25 to $V_{DD} + 10$ -15 to +25 -1.0 to $V_{DD} + 0.25$ | V |
| I_{IN} | DC Input Current, per Pin | ± 10 | mA |
| I_{OUT} | DC Output Current, per Pin | ± 25 | mA |
| I_{DD} | DC Supply Current, V_{DD}/V_{SS} pins (15 Seconds in Reverse Dir.) | +25 Forward -150 Reverse | mA |
| P_D | Power Dissipation † in Still Air, 5 sec. †† Continuous | 1200 ⁽²⁾ 350 ⁽³⁾ | mW |
| T_{stg} | Storage Temperature | -55 to +125 | °C |
| T_A | Operating Temperature | -25 to +75 | °C |
| T_L | Lead Temperature, 1 mm from case for 10 seconds | 260 | °C |

1. Maximum ratings are those values beyond which damage to the device may occur. Functional operation should be restricted to the limits in the electrical characteristics tables.
2. Derating: -12 mW/°C from 25°C to 60°C.
3. Derating: -3.5 mW/°C from 25°C to 60°C.

This device contains protection circuitry to guard against damage due to high static voltages or electric fields. However, precautions must be taken to avoid applications of voltages any higher than maximum rated voltages to this high-impedance circuit. For proper operation, V_{IN} and V_{OUT} should be constrained to a range of $V_{SS} \leq (V_{IN}$ or

$V_{OUT}) \leq V_{DD}$ except for I/O pin which can exceed V_{DD} , and the Test/Mute input, which can go below V_{SS} .

Unused inputs must always be tied to an appropriate logic voltage level (e.g. either V_{SS} or V_{DD}). Unused outputs and/or an unused I/O must be left open.

Table 2. Electrical Characteristics (Voltages Referenced to V_{SS} , $T_A = -10$ to 60°C unless otherwise indicated.)

| Symbol | Parameter | Test Condition | Test Pin | V_{DD} | Min | Max | Unit |
|----------|---|---|------------------------|----------------------|------------------------------|------------------------------|---------|
| V_{DD} | Power Supply Voltage Range | | — | — | 6.0 | 12 | V |
| V_{TH} | Supply Threshold Voltage, Low Supply Alarm | Low Supply Trip: $V_{IN} = V_{DD}/3$ | 15 | — | 7.2 | 7.8 | V |
| I_{DD} | Average Operating Supply Current (per Package) (Does not include Current through D3-IR Emitter) | Standby Configured per Figure 5 | — — | 12 9.0 | — — | 9.0 7.0 | μA |
| I_{DD} | Peak Supply Current (per Package) (Does not include IRED Current into base of Q1) | During Strobe On, IRED Off Configured per Figure 5 During Strobe On, IRED On Configured per Figure 5 | — — | 12 12 | — — | 1.25 2.5 | mA |
| V_{IL} | Low Level Input Voltage I/O Feedback Test | | 7.0 10 16 | 9.0 9.0 9.0 | — — — | 1.5 2.7 0.5 | V |
| V_{IM} | Mid Level Input Voltage Test | | 16 | 9.0 | 2.0 | $V_{DD}-2.0$ | V |
| V_{IH} | High Level Input Voltage I/O Feedback Test | | 7.0 10 16 | 9.0 9.0 9.0 | 3.2 6.3 8.5 | — — — | V |
| I_{IN} | Input Current OSC, Detect Low-Supply Trip Feedback Test | $V_{IN} = V_{SS}$ or V_{DD} $V_{IN} = V_{SS}$ or V_{DD} $V_{IN} = V_{SS}$ or V_{DD} $V_{IN} = V_{SS}$ or V_{DD} | 3.12 15 10 16 | 12 12 12 12 | -100 -100 -100 -100 | +100 +100 +100 +100 | nA |
| I_{IL} | Test Mode Input Current | $V_{IN} = V_{SS}$ or V_{DD} | 16 | 12 | -100 | -1.0 | μA |

Table 2. Electrical Characteristics (Voltages Referenced to V_{SS} , $T_A = -10$ to 60°C unless otherwise indicated.) (continued)

| Symbol | Parameter | Test Condition | Test Pin | V_{DD} | Min | Max | Unit |
|--------------|---|--|----------|----------|----------------|----------------|---------------|
| I_{IH} | Pull-Down Current Test I/O | $V_{IN} = V_{DD}$ I/O $V_{IN} = V_{DD}$ I/O $V_{IN} = 17\text{ V}$ | 16 | 12 | — | -1.0 | μA |
| | | | 7.0 | 9.0 | 0.5 | 1.0 | μA |
| | | | | 9.0 | 25 | 100 | |
| | | | | 12 | — | 140 | |
| V_{OL} | Low-Level Output Voltage LED Silver, Brass | $I_{OUT} = 10\text{ mA}$ $I_{OUT} = 16\text{ mA}$ | 11 | 6.5 | — | 0.6 | V |
| | | | 8.9 | 6.5 | — | 1.0 | |
| V_{OH} | High-Level Output Voltage Silver, Brass | $I_{OUT} = -16\text{ mA}$ | 8.9 | 6.5 | 5.5 | — | V |
| V_{OUT} | Output Voltage (For Line Regulation, See Pin Descriptions) Strobe | Inactive, $I_{OUT} = 1.0\ \mu\text{A}$ Active, $I_{OUT} = 100$ to $500\ \mu\text{A}$ (Load Regulation) | 4.0 | — | $V_{DD}-0.1$ | — | V |
| | | | 9.0 | 9.0 | $V_{DD}-5.4$ | $V_{DD}-4.6$ | |
| I_{OH} | High-Level Output Current I/O | Local Smoke, $V_{OUT} = 4.5\text{ V}$ Local Smoke, $V_{OUT} = V_{SS}$ (Short Circuit Current) | 7.0 | 6.5 | -4.0 | — | mA |
| | | | — | 12 | — | -16 | |
| I_{OZ} | Off-State Output Leakage Current LED | $V_{OUT} = V_{SS}$ or V_{DD} | 11 | 12 | — | ± 100 | nA |
| V_{OL} | Active | 1.0 mA | — | 6.5 | — | 0.5 | V |
| V_{IC} | Common Mode Voltage Range C1, C2, Detect | Local Smoke, Pushbutton, or Chamber Sensitivity Test | — | — | $V_{DD}-4.0$ | $V_{DD}-2.0$ | V |
| V_{REF} | Smoke Comparator Reference Voltage Internal | Local Smoke, Pushbutton, or Chamber Sensitivity Test | — | — | $V_{DD}-3.9$ | $V_{DD}-3.1$ | V |
| V_{REF-HI} | High Smoke Comparator Reference Voltage Internal | Local Smoke, Pushbutton, or Chamber Sensitivity Test | — | — | $V_{REF}-0.52$ | $V_{REF}-0.48$ | V |

* $T_A = 25^\circ\text{C}$ Only

Table 3. AC Electrical Characteristics (Refer to Timing Diagram [Figure 3](#) and [Figure 4](#). $T_A = 25^\circ\text{C}$, $V_{DD} = 9.0\text{ V}$, Component Values from [Figure 5](#).)

| No. | Symbol | Parameter | Test Condition | Clocks | Min ⁽¹⁾ | Typ ⁽²⁾ | Max ⁽¹⁾ | Unit |
|-----|--------------------------------|--|---|---------|--------------------|--------------------|--------------------|---------------|
| 1 | $1/f_{OSC}$ | Oscillator Period | Free-running Saw tooth Measured at Pin 12 | 1.0 | 7.2 | 8.0 | 8.8 | ms |
| 2 | t_{LED} | LED Pulse Period | No Local Smoke, and No Remote Smoke | 4096 | 28.8 | 32.4 | 35.2 | s |
| 3 | | | Remote Smoke, but No Local Smoke | — | — | Extinguished | — | |
| 4 | | | Local Smoke | 256 | 1.6 | 2.0 | 2.4 | |
| 5 | | | Pushbutton Test | 256 | 1.6 | 2.0 | 2.4 | |
| | | | Push button Test with Alarm Memory | 4.0 | 25.6 | 32 | 38.4 | ms |
| 6 | $t_{w(LED)}$, $t_{w(stb)}$ | LED Pulse Width and Strobe Pulse Width | Remote Smoke but No Local Smoke | 1.0 | OFF | — | OFF | — |
| 7 | (t_{IRED}) | (IRED Pulse Period) | Smoke Test | 1024 | 7.2 | 8.1 | 8.8 | s |
| 8 | | | Chamber Sensitivity Test, Without Local Smoke | 4096 | 28.8 | 32.4 | 35.2 | |
| 9 | | | Local Smoke, in Speed-Up | 128 | 0.9 | 1.0 | 1.1 | |
| | | | Pushbutton Test | 128 | 0.9 | 1.0 | 1.1 | |
| 10 | $t_{w(IRED)}$ | IRED Pulse Width | | T_f^* | 94 | — | 116 | μs |
| 11 | t_R | | | — | — | — | 30 | μs |
| 12 | t_F | | | — | — | — | 200 | μs |

Table 3. AC Electrical Characteristics (Refer to Timing Diagram [Figure 3](#) and [Figure 4](#). $T_A = 25^\circ\text{C}$, $V_{DD} = 9.0\text{ V}$, Component Values from [Figure 5.](#)) (continued)

| No. | Symbol | Parameter | Test Condition | Clocks | Min ⁽¹⁾ | Typ ⁽²⁾ | Max ⁽¹⁾ | Unit |
|-----|-------------|--|--|--------|--------------------|--------------------|--------------------|------|
| 13 | t_{ON} | Silver and Brass Temporal Modulation Pulse Width | | 64 | 0.45 | 0.5 | 0.55 | s |
| 14 | t_{OFF} | | | 64 | 0.45 | 0.5 | 0.55 | |
| 15 | t_{OFFD} | | | 192 | 1.35 | 1.52 | 1.65 | |
| 16 | t_{CH} | Silver and Brass Chirp Pulse Period | Low Supply or Degraded Chamber Sensitivity | 4096 | 28.8 | 32.4 | 35.2 | s |
| 17 | $t_{W(CH)}$ | Silver and Brass Chirp Pulse Width | Low Supply or Degraded Chamber Sensitivity | 1.0 | 7.2 | 8.0 | 8.8 | ms |
| 18 | t_{RR} | Rising Edge on I/O to Smoke Alarm Response Time | Remote Smoke, No local smoke | — | — | 2.0 ⁽³⁾ | — | s |
| 19 | t_{stb} | Strobe Out Pulse Period | Smoke Test | 1024 | 7.2 | 8.1 | 8.8 | s |
| 20 | | | Chamber Sensitivity Test Without Local Smoke | 4096 | 28.8 | 32.4 | 35.2 | s |
| 21 | | | Low Supply Test Without Local Smoke | 4096 | 28.8 | 32.4 | 35.2 | s |
| 22 | | | Pushbutton Test/Speed-Up | — | — | 1.0 | — | s |
| 23 | t_{MUTE} | | | — | 6.0 | 8.0 | 11 | min |

- Oscillator period T ($T = T_r + T_f$) is determined by the external components R_1 , R_2 and C_3 where $T_r = (0.6931)R_2 \cdot C_3$ and $T_f = (0.6931)R_1 \cdot C_3$. The other timing characteristics are some multiple of the oscillator timing shown in the table. The timing shown should accommodate the NFPA72, ANSI S3.41, and ISO8201 audible emergency evacuation signals.
- Typicals are not guaranteed.
- Time is typical—depends on what point in cycle the signal is applied.

Archive Information

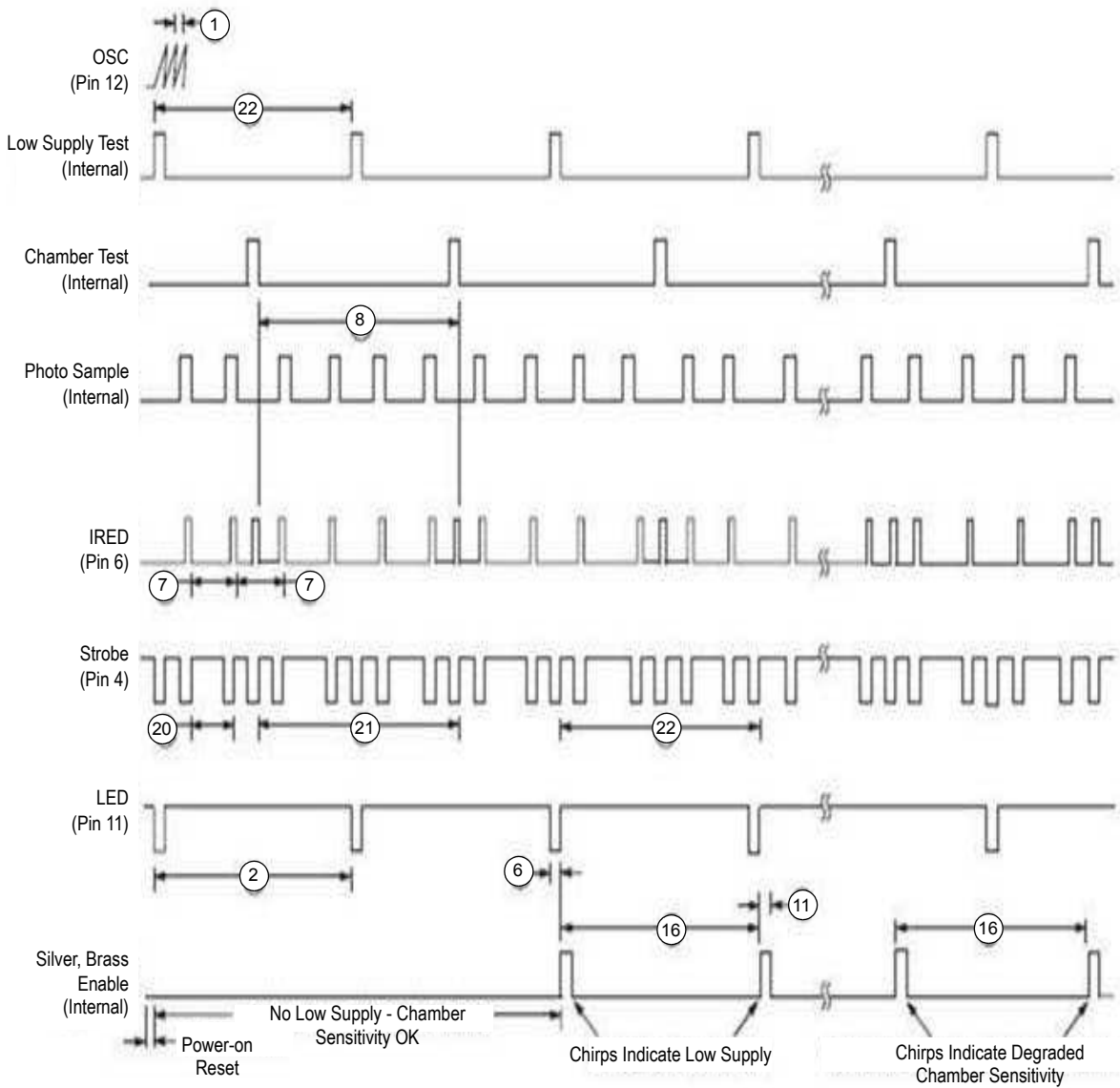

Figure 3. Typical Standby Timing Diagram MC146012 Device

Notes: Numbers refer to the AC Electrical Characteristics Table
Illustration is not to scale.

Archive Information

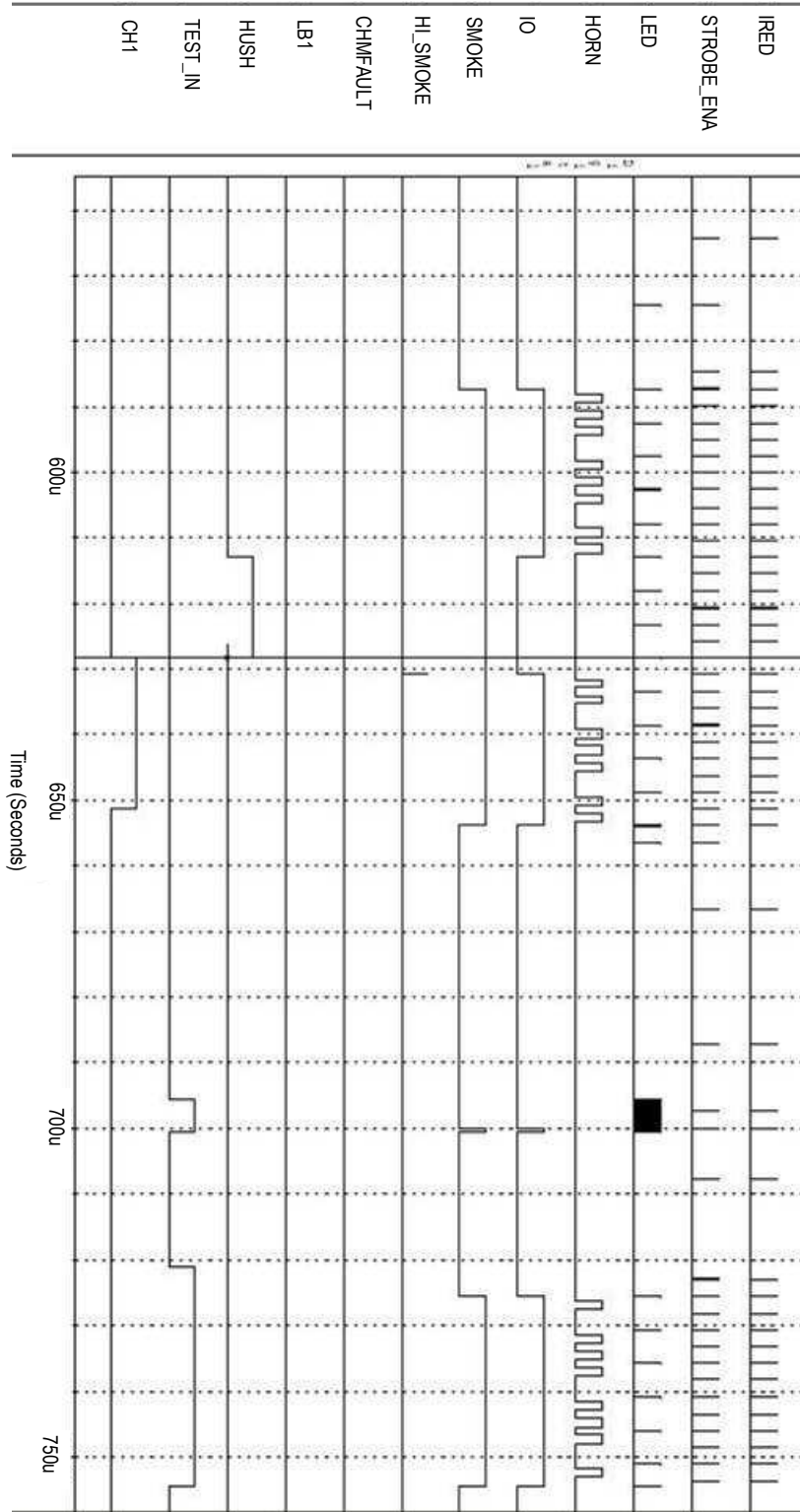

Figure 4. Typical Local Smoke Timing MC146012 Device

Archive Information

Archive Information

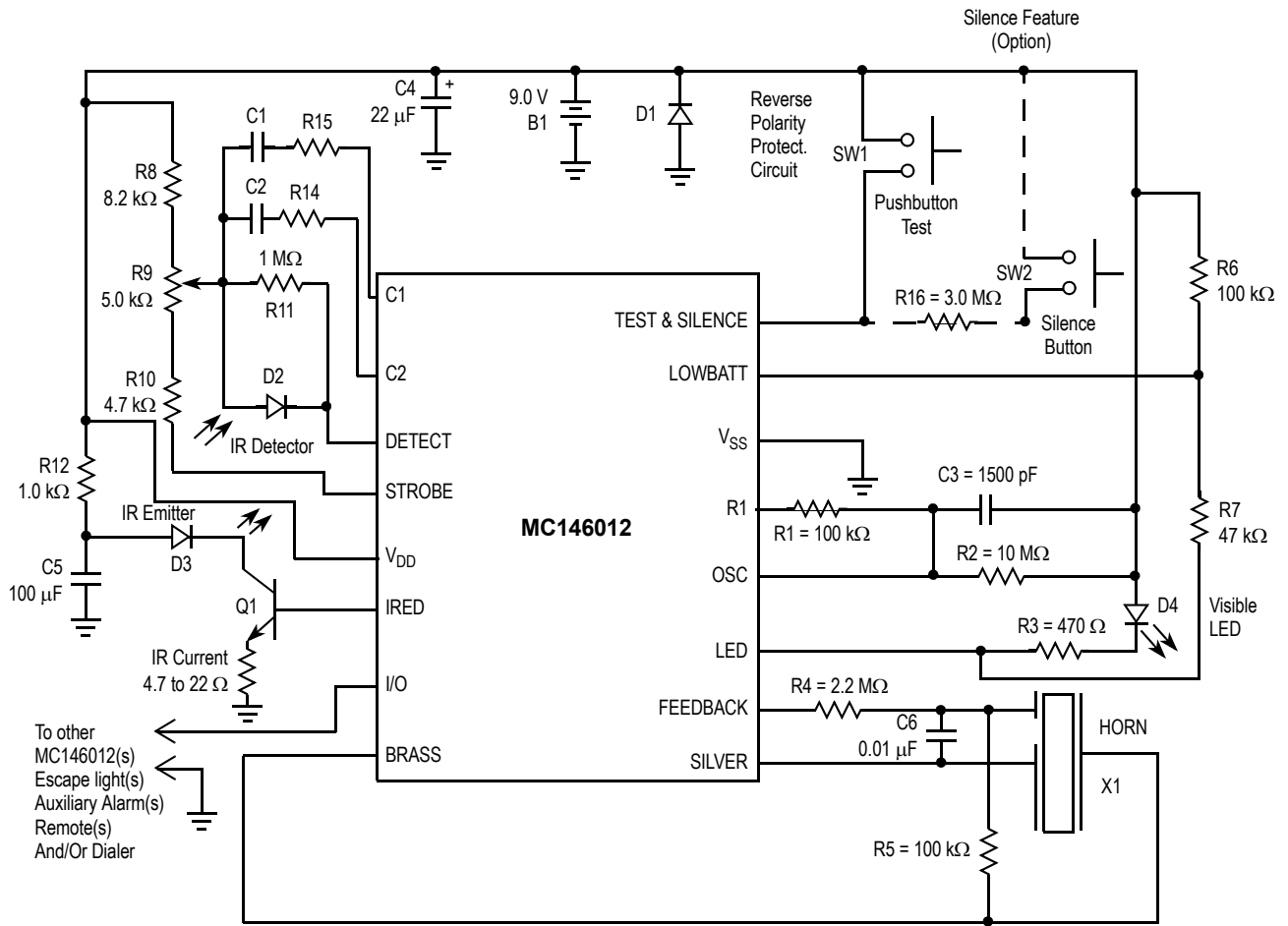

Figure 5. Typical Battery Powered Application

- # Values for R4, R5 and C6 may differ depending on type of horn used.
- * C2 and R13 are used for coarse sensitivity adjustment. Typical values are shown.
- † R9 is for fine sensitivity adjustment (optional). If fixed resistors are used, R8 = 12k, R10 is 5.6k to 10k and R9 is eliminated.
- ** Components necessary to utilize IMF feature.

PIN DESCRIPTIONS

C1 (PIN 1)

A capacitor connected to this pin as shown in [Figure 5](#) determines the gain of the on-chip photo amplifier during pushbutton test and chamber sensitivity test (high gain). The capacitor value is chosen such that the alarm tripped from background reflections in the chamber during pushbutton test.

$AV = 1 + (C1/10)$ where C1 is in pF. CAUTION: The value of the closed-loop gain should not exceed 10,000.

Resistor R15 should be installed in series with C1 for lower gains. $R15 = [1 / (12\sqrt{C1} - 680)]$ where R15 is in ohms and C1 is in farads.

C2 (PIN 2)

A capacitor connected to this pin as shown in [Figure 5](#) determines the gain of the on-chip photo amplifier during pushbutton test and chamber sensitivity tests.

$AV = 1 + (C2/10)$ where C1 is in pF. This gain increases about 10% during IRED pulse, after two consecutive local smoke detections.

For proper compensation, resistor R14 must be installed in series with C2. $R14 = [1 / (12\sqrt{C2} - 680)]$ where R14 is in ohms and C1 is in farads.

DETECT (PIN 3)

This input to the high-gain pulse amplifier is tied to the cathode of an external photodiode. The photodiode should have low capacitance and low dark leakage current. The diode must be shunted by a load resistor and is operated at zero bias.

The Detect input must be ac/dc decoupled from all other signals, V_{DD} and V_{SS} . Lead length and/or foil traces to this pin must be minimized also. See [Figure 3](#).

The device has a sampling speed-up mode after the first smoke sample is detected. The speed-up frequency is one smoke sample about every 2 seconds for the duration of a smoke condition. It will take no-smoke samples to return to a standby mode. Once out of a smoke condition, the IC will continue to sample for smoke about every 8 seconds.

STROBE (PIN 4)

This output provides the strobed, regulated voltage referenced to V_{DD} . The temperature coefficient of this voltage is $\pm 0.2\%/^{\circ}\text{C}$ maximum from -10 to 60°C. The supply-voltage coefficient (line regulation) is $\pm 0.2\%/V$ maximum from 6.0 to 12 V. Strobe is tied to external resistor string R8, R9 and R10.

 V_{DD} (PIN 5)

This pin is connected to the positive supply potential and may range from +6.0 to +12 V with respect to V_{SS} .

CAUTION: In battery-powered applications, reverse-polarity protection must be provided externally.

IRED (PIN 6)

This output provides pulsed base current for external NPN transistor Q1 used as the infrared emitter driver. Q1 must have a $\beta \geq 100$. At 10 mA, the temperature coefficient of the

output voltage is typically $+0.5\%/^{\circ}\text{C}$ from -10 to 60°C. The supply-voltage coefficient (line regulation) is $\pm 0.2\%/V$ maximum from 6.0 to 12 V. The IRED pulse width (active-high) is determined by external components R1 and C3. With a 100 k Ω /1500 pF combination, the nominal width is 105 μs .

To minimize noise impact, IRED is active near the end of strobe pulses for smoke tests, chamber sensitivity test, and pushbutton test. For the above mentioned width, IRED will be active for the last 105 μs of strobe pulse.

I/O (PIN 7)

This pin can be used to connect up to 40 units together in a wired-OR configuration for common signaling. V_{SS} is used as the return. An on-chip current sink minimizes noise pickup during non-smoke conditions and eliminates the need for an external pull-down resistor to complete the wired-OR. Remote units at lower supply voltages do not draw excessive current from a sending unit at higher supply voltage.

I/O can also be used to activate escape lights, auxiliary alarms, remote alarms and/or auto-dialers.

As an input, this pin feeds a positive-edge-triggered flip-flop whose output is sampled nominally every 1 second during standby (using typical component values). Once the first I/O remote smoke sample is detected, a second sample approximately 10 ms later will happen to confirm a remote smoke condition. If both samples are found to be high, the unit will start sounding an alarm.

I/O is disabled by the on-chip power-on reset to eliminate nuisance signaling during battery changes or system power-up.

If unused, I/O must be left unconnected.

BRASS (PIN 8)

This half of the push-pull driver output is connected to the metal support electrode of the piezoelectric audio transducer and to the horn-starting resistor. A continuous modulated tone from the transducer is a smoke alarm indicating either local or remote smoke. A short beep or chirp is a trouble alarm indicating a low supply or degraded chamber sensitivity. A series of short beeps or chirps during a pushbutton test indicate a previous alarm for detected smoke (Alarm memory feature).

SILVER (PIN 9)

This half of the push-pull driver output is connected to the ceramic electrode of a piezoelectric transducer and to the horn-starting capacitor.

FEEDBACK (PIN 10)

This input is connected to both the feedback electrode of a self-resonating piezoelectric transducer and the horn-starting resistor and capacitor through current limiting resistor R4. If unused, the pin must be tied to V_{SS} or V_{DD} .

LED (PIN 11)

This active-low open drain output directly drives an external visible LED at the pulse rate indicated below. The pulse width is equal to the OSC period.

The load for the low-supply test is non-coincident with the smoke tests, chamber sensitivity test, pushbutton test, or any alarm signals.

The LED also provides a visual indication of the detector status as follows, assuming the component values shown in [Figure 4](#):

Standby (includes low-supply and chamber sensitivity tests) — Pulses every 32.4 seconds.

Local Smoke — Pulses every 2.0 seconds (typical)

Mute — Pulses every 2.0 seconds (typical)

Remote Smoke — No Pulses

Pushbutton test — Pulses every 2.0 seconds

OSC (PIN 12)

This pin is used in conjunction with external resistor R2 (7.5 M Ω) to V_{DD} and external capacitor C3 (1500 pF) to V_{DD} to form an oscillator with a nominal period of 7.9 msec (typical).

R1 (PIN 13)

This pin is used in conjunction with resistor R1 (100 k Ω) to pin 12 and C3 (1500 pF, see pin 12 description) to determine the IRED pulse width. With this RC combination, the nominal pulse width is 105 μ s.

V_{SS} (PIN 14)

This pin is the negative supply potential and the return for the I/O pin. Pin 14 is usually tied to Ground.

LOW-SUPPLY TRIP (PIN 15)

This pin is connected to an external voltage which determines the low-supply alarm threshold. The trip voltage is obtained through a resistor divider connected between the V_{DD} and LED pins. The low-supply alarm threshold voltage (in volts) = (5R7/R6)+5 where R6 and R7 are in the same units.

TEST/MUTE (PIN 16)

This input has an on-chip pull-down device and is used to manually invoke a test mode, a mute mode, or a calibration mode.

The *Pushbutton Test* mode is initiated by a high level at Pin 16 (usually a depression of a S.P.S.T. normally-open pushbutton switch to V_{DD}). After one oscillator cycle, the IRED pulses approximately every 1.0 second, regardless of the presence of smoke. Additionally, the amplifier gain is increased by automatic selection of C1. Therefore the background reflections in the smoke chamber may be interpreted as smoke, generating a simulated smoke condition. After the second IRED pulse, a successful test activates the horn-driver and I/O circuits. The active I/O allows remote signaling for a system testing. When the Pushbutton Test switch is released, the Test input returns to V_{SS} due to the on-chip pull-down device. After one oscillator

cycle, the amplifier gain returns to normal, thereby removing the simulated smoke condition. After two additional IRED pulses, less than three seconds, the IC exits the alarm mode and returns to standby timing.

The *Pushbutton Test* will also activate the *Alarm Memory* feature. If there was a previous alarm detected by the unit, the horn will chirp every ¼ second as long as the Test Button is pressed. Upon releasing of the Test Button, Alarm memory will be reset. Subsequent pressing of the Test Button will result in a *Pushbutton Test* for simulated smoke.

Pressing the Test Button while in the MUTE mode will result in resetting of MUTE (and additionally a normal Pushbutton Test).

The MUTE mode (IMF) is initiated by a mid level voltage (around ½ V_{DD}) at pin 16. A parallel Mute Button to an existing Test Button needs to be installed at the test pin. A smoke condition must be present for the MUTE mode to be activated. If a no smoke condition gets detected while in the MUTE mode, the IMF 8 minute window gets reset. The unit will return to Standby mode.

Once in the MUTE mode, the audible smoke alarm (horn) is temporarily disabled for approximately 8 minutes while smoke condition is being detected. A visual smoke alarm will remain (LED flashing) during MUTE mode. A high smoke voltage reference will also be activated at this time. Simultaneous smoke and high smoke sampling will allow the unit to enable the horn driver in case a high smoke condition occurs during MUTE where the high smoke threshold is crossed.

The MUTE mode can be overridden by the following conditions: 1) a no smoke condition is detected, 2) high smoke level detected, 3) remote smoke detected through I/O, 4) reset through test Button, 5) timeout of 8 minute window. To help prevent a jammed Mute Button condition, the divider string on the Mute Button should include a resistor to V_{DD}, R15 (around 10 M Ω) and a resistor R16 (4.7 M Ω) and capacitor, C7 (0.047 mF) in series to V_{SS}.

CALIBRATION

To facilitate checking the sensitivity and calibrating smoke detectors, the MC146012 can be placed in Calibration mode. In this mode, certain device pins are controlled/reconfigured as shown in [Table 4](#). To place the part in Calibration mode, Pin 16 (Test/ Mute) must be pulled below V_{SS} pin with 100 μ A continuously drawn out of the pin for at least one cycle of the OSC pin. To exit this mode, the Test/ Mute pin is floated for at least one OSC cycle.

In the Calibration mode, the IRED pulse rate is increased. An IRED pulse occurs every clock cycle. Also, Strobe is always Active Low. It is recommended to short R12 ([Figure 5](#)) in this mode. This will allow for a similar recovery of the emitter circuitry as in normal operation. Pin 1, pin 2, and pin 12 should be buffered with a unity gain amplifier to measure their outputs.

Table 4. MC146012 Test Mode Logic Table

| Pin | Function | Type | Logic | Description |
|-------------------------|------------------------------|--------|-------|---|
| Pin 16, TEST | Test Mode 1 Trigger | Input | None | Set a -Ve voltage to the pin and source 100 μ A from the pin to start Test Mode 1. |
| Pin 12, OSC CAP | Clock Input | Input | 0 | Internal clock low |
| | | | 1 | Internal clock high |
| Pin 5, V _{DD} | Chip Power | | | |
| Pin 14, V _{SS} | Chip Ground | | | |
| Pin 11, LED | Built-in-Test for HUSH Timer | Output | | Output pulse active low for 8 Clocks every 128 Clocks. |
| Pin 4, STROBE | Analog Ground | Output | | Output low when pin 12 is low. |
| Pin 6, IRED | IRED | Output | 0 | Output low when pin 12 is low. |
| | | | 1 | Output high (3.0 V) when pin 12 is high. |
| Pin 3, DETECT | Smoke Sensing Input | Input | | NO SMK: V _{DD} -2.5 V – (1/Hi Gain) |
| | | | | SMK: V _{DD} -2.5 V – (1/Low Gain) |
| | | | | HI SMK: V _{DD} -2.5 V – (2/Low Gain) |
| Pin 8, BRASS | Smoke Latch Indicator | Output | 0 | Output low when smoke latch not set. |
| | | | 1 | Output high when smoke latch set. |
| Pin 9, SILVER | Photo-Comparator Indicator | Output | 0 | Output low when photo comparator not set. |
| | | | 1 | Output high when photo comparator set. |
| Pin 7, I/O | Photo-Amp Routing Enable | Input | 0 | Disable the function of Pin 1, 2, 10 and 15 in Test Mode 1. |
| | | | 1 | Enable photoamplifier output routed to the pins and enable pins 1, 2, 10 and 15 in test Mode 1. |
| Pin 15, LOW_BATT | Low Battery Trip Point | Input | | Control photo amp. Gain and output routing |
| Pin 10, FEEDBACK | Feedback | Input | | Control hysteresis |

Archive Information

Archive Information

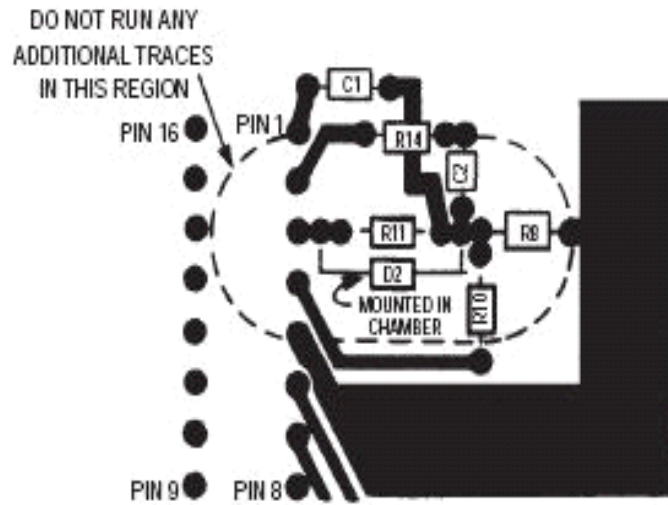

- NOTES: Illustration is bottom view of layout using a DIP. Top view for SOIC layout is mirror image.
 Optional potentiometer R9 is not included.
 Drawing is not to scale.
 Leads on D2, R11, R8, and R10 and their associated traces must be kept as short as possible.
 This practice minimizes noise pick up.
 Pin 3 must be decoupled from all other traces.

Figure 6. Recommended PCB layout

PACKAGE DIMENSIONS

Archive Information

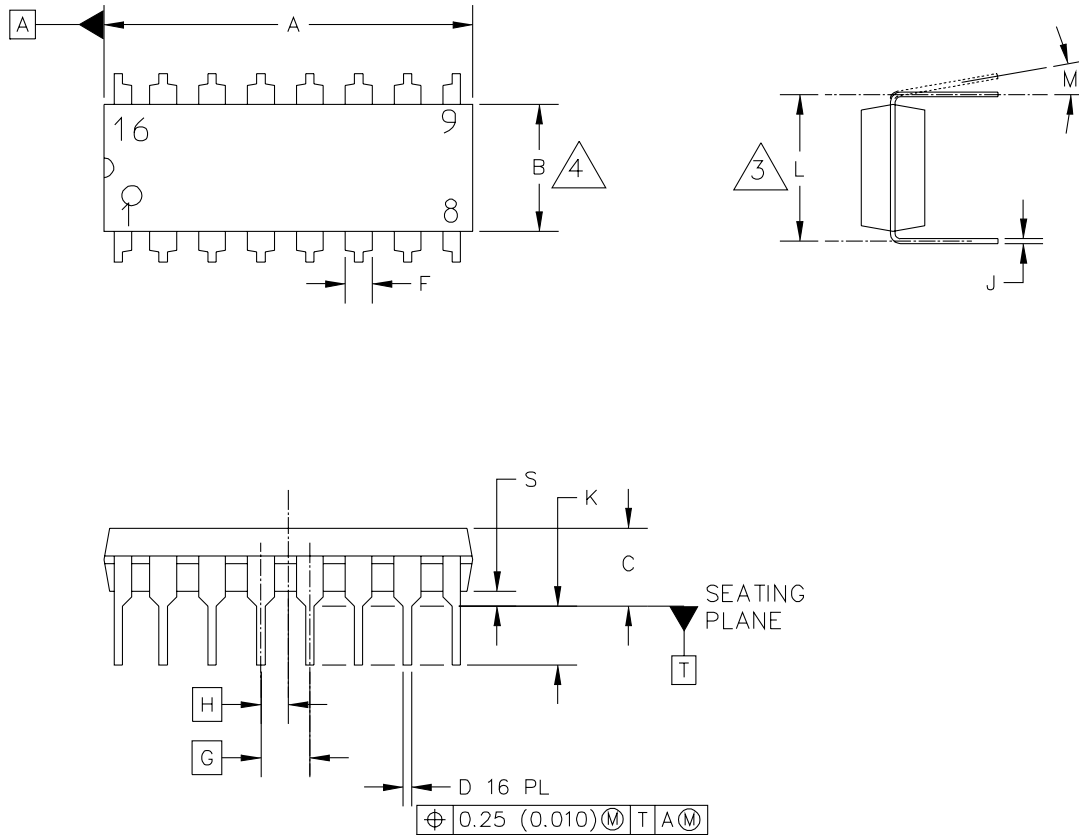

Archive Information

| | | | |
|---|--------------------------|----------------------------|--|
| © FREESCALE SEMICONDUCTOR, INC. ALL RIGHTS RESERVED. | MECHANICAL OUTLINE | PRINT VERSION NOT TO SCALE | |
| TITLE: 16 LD PDIP | DOCUMENT NO: 98ASB42431B | REV: T | |
| | CASE NUMBER: 648-08 | 19 MAY 2005 | |
| | STANDARD: NON-JEDEC | | |

PAGE 1 OF 3

98ASB42431B
ISSUE T
PLASTIC DIP

MC146012

PACKAGE DIMENSIONS

NOTES:

1. DIMENSIONING AND TOLERANCING PER ASME Y14.5M, 1994.
2. CONTROLLING DIMENSION: INCH.
3. DIMENSION TO CENTER OF LEADS WHEN FORMED PARALLEL.
4. DIMENSIONS DOES NOT INCLUDE MOLD FLASH.
5. ROUNDED CORNERS OPTIONAL.
6. 648-01 THRU -08 OBSOLETE, NEW STANDARD 648-09.

Archive Information

Archive Information

| DIM | MILLIMETERS | | INCHES | | DIM | MILLIMETERS | | INCHES | |
|---|-------------|-------|--------------------|-------|--------------------------|----------------------------|-----|-------------|-----|
| | MIN | MAX | MIN | MAX | | MIN | MAX | MIN | MAX |
| A | 18.80 | 19.55 | 0.740 | 0.770 | | | | | |
| B | 6.35 | 6.85 | 0.250 | 0.270 | | | | | |
| C | 3.69 | 4.44 | 0.145 | 0.175 | | | | | |
| D | 0.39 | 0.53 | 0.015 | 0.021 | | | | | |
| F | 1.02 | 1.77 | 0.040 | 0.070 | | | | | |
| G | 2.54 BSC | | 0.100 BSC | | | | | | |
| H | 1.27 BSC | | 0.050 BSC | | | | | | |
| J | 0.21 | 0.38 | 0.008 | 0.015 | | | | | |
| K | 2.80 | 3.30 | 0.110 | 0.130 | | | | | |
| L | 7.50 | 7.74 | 0.295 | 0.305 | | | | | |
| M | 0° | 10° | 0° | 10° | | | | | |
| S | 0.51 | 1.01 | 0.020 | 0.040 | | | | | |
| © FREESCALE SEMICONDUCTOR, INC. ALL RIGHTS RESERVED. | | | MECHANICAL OUTLINE | | | PRINT VERSION NOT TO SCALE | | | |
| TITLE: 16 LD PDIP | | | | | DOCUMENT NO: 98ASB42431B | | | REV: T | |
| | | | | | CASE NUMBER: 648-08 | | | 19 MAY 2005 | |
| | | | | | STANDARD: NON-JEDEC | | | | |

**98ASB42431B
ISSUE T
PLASTIC DIP**

PACKAGE DIMENSIONS

Archive Information

Archive Information

STYLE 1:

- PIN 1. CATHODE
- 2. CATHODE
- 3. CATHODE
- 4. CATHODE
- 5. CATHODE
- 6. CATHODE
- 7. CATHODE
- 8. CATHODE
- 9. ANODE
- 10. ANODE
- 11. ANODE
- 12. ANODE
- 13. ANODE
- 14. ANODE
- 15. ANODE
- 16. ANODE

STYLE 2:

- PIN 1. COMMON DRAIN
- 2. COMMON DRAIN
- 3. COMMON DRAIN
- 4. COMMON DRAIN
- 5. COMMON DRAIN
- 6. COMMON DRAIN
- 7. COMMON DRAIN
- 8. COMMON DRAIN
- 9. GATE
- 10. SOURCE
- 11. GATE
- 12. SOURCE
- 13. GATE
- 14. SOURCE
- 15. GATE
- 16. SOURCE

| | | | |
|---|--------------------------|----------------------------|--|
| © FREESCALE SEMICONDUCTOR, INC. ALL RIGHTS RESERVED. | MECHANICAL OUTLINE | PRINT VERSION NOT TO SCALE | |
| TITLE: 16 LD PDIP | DOCUMENT NO: 98ASB42431B | REV: T | |
| | CASE NUMBER: 648-08 | 19 MAY 2005 | |
| | STANDARD: NON-JEDEC | | |

PAGE 3 OF 3

**98ASB42431B
ISSUE T
PLASTIC DIP**

MC146012

PACKAGE DIMENSIONS

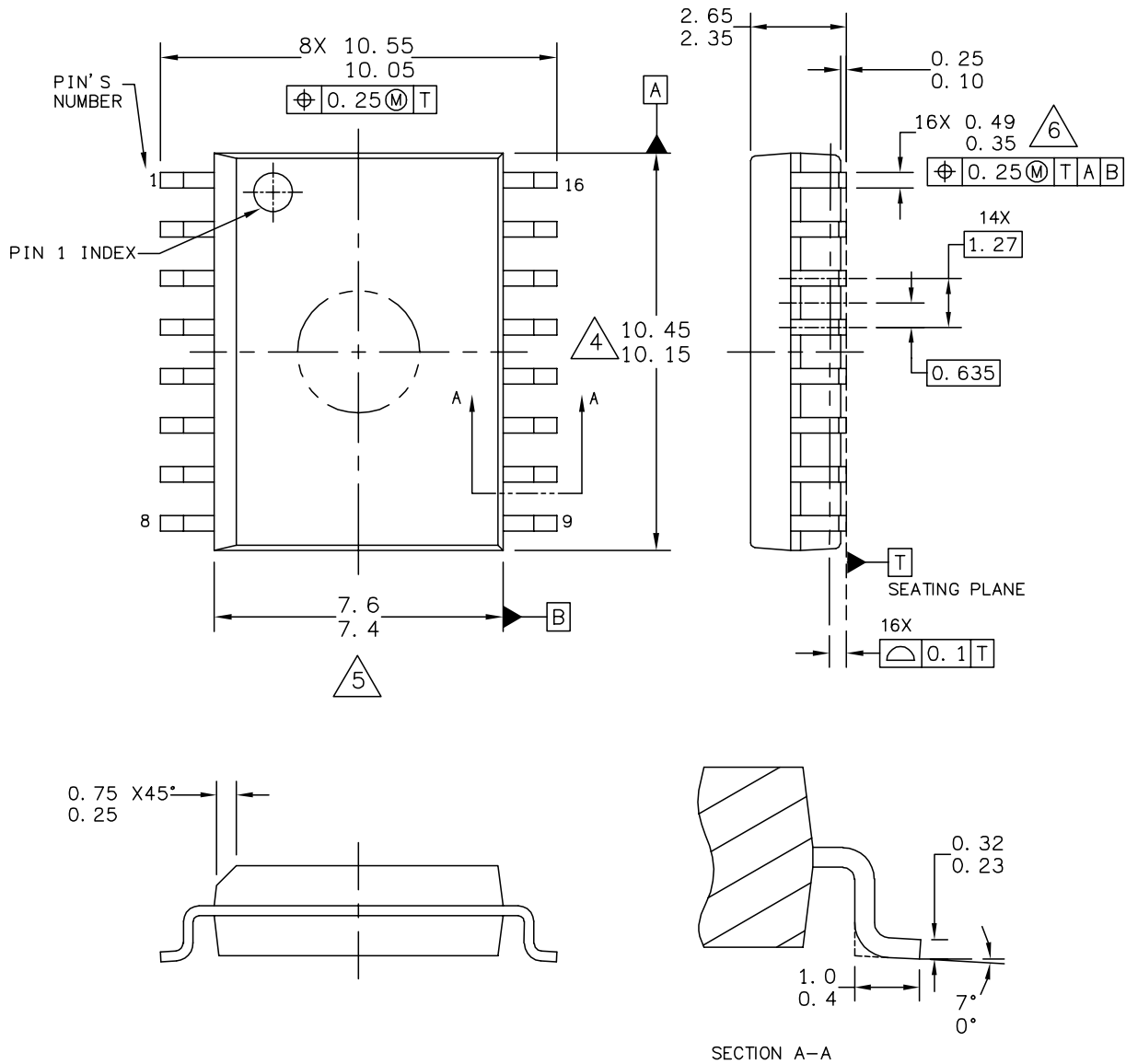

Archive Information

Archive Information

| | | | |
|---|---------------------------|----------------------------|--|
| © FREESCALE SEMICONDUCTOR, INC. ALL RIGHTS RESERVED. | MECHANICAL OUTLINE | PRINT VERSION NOT TO SCALE | |
| TITLE: 16LD SOIC W/B, 1.27 PITCH CASE-OUTLINE | DOCUMENT NO: 98ASB42567B | REV: F | |
| | CASE NUMBER: 751G-04 | 02 JUN 2005 | |
| | STANDARD: JEDEC MS-013AA | | |

PAGE 1 OF 2

**98ASB42567B
ISSUE F
SOIC PACKAGE**

PACKAGE DIMENSIONS

NOTES:

1. DIMENSIONS ARE IN MILLIMETERS.
2. DIMENSIONING AND TOLERANCING PER ASME Y14.5M-1994.
3. DATUMS A AND B TO BE DETERMINED AT THE PLANE WHERE THE BOTTOM OF THE LEADS EXIT THE PLASTIC BODY.
4. THIS DIMENSION DOES NOT INCLUDE MOLD FLASH, PROTRUSION OR GATE BURRS. MOLD FLASH, PROTRUSION OR GATE BURRS SHALL NOT EXCEED 0.15 MM PER SIDE. THIS DIMENSION IS DETERMINED AT THE PLANE WHERE THE BOTTOM OF THE LEADS EXIT THE PLASTIC BODY.
5. THIS DIMENSION DOES NOT INCLUDE INTER-LEAD FLASH OR PROTRUSIONS. INTER-LEAD FLASH AND PROTRUSIONS SHALL NOT EXCEED 0.25 MM PER SIDE. THIS DIMENSION IS DETERMINED AT THE PLANE WHERE THE BOTTOM OF THE LEADS EXIT THE PLASTIC BODY.
6. THIS DIMENSION DOES NOT INCLUDE DAMBAR PROTRUSION. ALLOWABLE DAMBAR PROTRUSION SHALL NOT CAUSE THE LEAD WIDTH TO EXCEED 0.62 mm.

Archive Information

Archive Information

| | | | |
|---|---------------------------|----------------------------|--|
| © FREESCALE SEMICONDUCTOR, INC. ALL RIGHTS RESERVED. | MECHANICAL OUTLINE | PRINT VERSION NOT TO SCALE | |
| TITLE: 16LD SOIC W/B, 1.27 PITCH, CASE OUTLINE | DOCUMENT NO: 98ASB42567B | REV: F | |
| | CASE NUMBER: 751G-04 | 02 JUN 2005 | |
| | STANDARD: JEDEC MS-013AA | | |

PAGE 2 OF 2

**98ASB42567B
ISSUE F
SOIC PACKAGE**

How to Reach Us:

Home Page:
www.freescale.com

E-mail:
support@freescale.com

USA/Europe or Locations Not Listed:
Freescale Semiconductor
Technical Information Center, CH370
1300 N. Alma School Road
Chandler, Arizona 85224
+1-800-521-6274 or +1-480-768-2130
support@freescale.com

Europe, Middle East, and Africa:
Freescale Halbleiter Deutschland GmbH
Technical Information Center
Schatzbogen 7
81829 Muenchen, Germany
+44 1296 380 456 (English)
+46 8 52200080 (English)
+49 89 92103 559 (German)
+33 1 69 35 48 48 (French)
support@freescale.com

Japan:
Freescale Semiconductor Japan Ltd.
Headquarters
ARCO Tower 15F
1-8-1, Shimo-Meguro, Meguro-ku,
Tokyo 153-0064
Japan
0120 191014 or +81 3 5437 9125
support.japan@freescale.com

Asia/Pacific:
Freescale Semiconductor Hong Kong Ltd.
Technical Information Center
2 Dai King Street
Tai Po Industrial Estate
Tai Po, N.T., Hong Kong
+800 2666 8080
support.asia@freescale.com

For Literature Requests Only:
Freescale Semiconductor Literature Distribution Center
P.O. Box 5405
Denver, Colorado 80217
1-800-441-2447 or 303-675-2140
Fax: 303-675-2150
LDCForFreescaleSemiconductor@hibbertgroup.com

Information in this document is provided solely to enable system and software implementers to use Freescale Semiconductor products. There are no express or implied copyright licenses granted hereunder to design or fabricate any integrated circuits or integrated circuits based on the information in this document.

Freescale Semiconductor reserves the right to make changes without further notice to any products herein. Freescale Semiconductor makes no warranty, representation or guarantee regarding the suitability of its products for any particular purpose, nor does Freescale Semiconductor assume any liability arising out of the application or use of any product or circuit, and specifically disclaims any and all liability, including without limitation consequential or incidental damages. "Typical" parameters that may be provided in Freescale Semiconductor data sheets and/or specifications can and do vary in different applications and actual performance may vary over time. All operating parameters, including "Typicals", must be validated for each customer application by customer's technical experts. Freescale Semiconductor does not convey any license under its patent rights nor the rights of others. Freescale Semiconductor products are not designed, intended, or authorized for use as components in systems intended for surgical implant into the body, or other applications intended to support or sustain life, or for any other application in which the failure of the Freescale Semiconductor product could create a situation where personal injury or death may occur. Should Buyer purchase or use Freescale Semiconductor products for any such unintended or unauthorized application, Buyer shall indemnify and hold Freescale Semiconductor and its officers, employees, subsidiaries, affiliates, and distributors harmless against all claims, costs, damages, and expenses, and reasonable attorney fees arising out of, directly or indirectly, any claim of personal injury or death associated with such unintended or unauthorized use, even if such claim alleges that Freescale Semiconductor was negligent regarding the design or manufacture of the part.

Freescale™ and the Freescale logo are trademarks of Freescale Semiconductor, Inc. All other product or service names are the property of their respective owners.

© Freescale Semiconductor, Inc., 2007. All rights reserved.