

Technical Data

MC44BC380/D
Rev. 1.3 09/2002

MC44BC380
VHF/ UHF ANTENNA
BOOSTER/SPLITTER
IC

MC44BC380

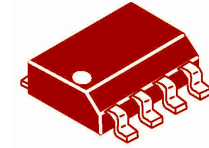

SO8 Package

Ordering Information		
Device	Temp. Range	Package
MC44BC380D, R2	-20°C to +85°C	SO8NB
NOTE: For tape and reel, add R@ suffix.		

Freescale Semiconductor, Inc.

1 Features 2
 2 Functional Description 3
 3 Maximum Ratings 3
 4 Antenna/Booster Splitter Electrical Characteristics 4
 5 IC Block Diagram 6
 6 Diagrams 7

This modulator circuit is for use in VCRs, set top boxes, and similar devices.

Figure 1 shows the pin connections.

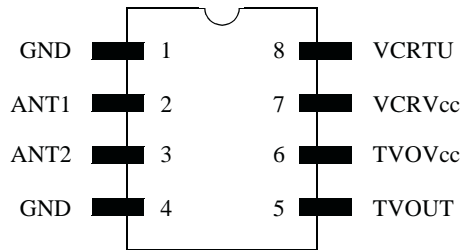

Figure 1. Pin Connections



This document contains information on a product under development. Freescale reserves the right to change or discontinue this product without notice. © Motorola, Inc., 2002. All rights reserved.

1 Features

This circuit is developed using Motorola RF BiCMOS technology. With a transmit frequency of 18GHz, the Antenna Booster/Splitter allows high RF performance at low cost.

The Antenna Booster/Splitter function boosts the antenna signal, then splits it into two (2) 75 Ohm outputs for the TV and auxiliary outputs. Main applications are for:

- Set-Top Box (STB)
- VCR tuner
- PIP TV
- Video games

RF output of the STB or VCR is added to the boosted received antenna signal.

The MC44BC380 has the following features:

- Frequency operation range (40MHz to 880MHz)
- Extremely low external component count
- Low power consumption (35mA typical)
- Balanced inputs for low distortion
- Balanced amplifiers for maximum isolation

2 Functional Description

Figure 2 is a simplified block diagram, which shows the basic circuit functionality.

The MC44BC380 has separate Vccs and a maximum grounding pattern to ensure high performance in terms of isolation and leakage.

The MC44BC380 comes in an SO8 package and has a minimum pin count, which reduces cost and application board space.

NOTE:

A BALUN is required at the input to achieve the stated performance.

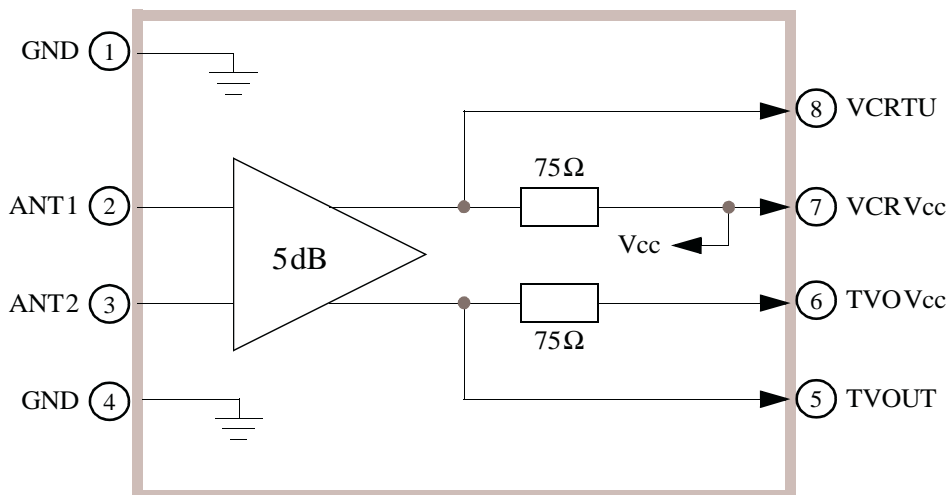

Figure 2. Simplified Block Diagram—MC44BC380

3 Maximum Ratings

Sym	Parameter	Value	Unit
Vcc1	Supply voltage	6	V
Tamin	Minimum operating ambient temperature	-10	°C
Tamax	Maximum operating ambient temperature	75	°C
Tstgmin	Minimum storage temperature	-65	°C
Tstgmax	Maximum storage temperature	150	°C

This device contains protection circuitry to guard against damage due to high static voltage or electric fields. However, precautions must be taken to avoid applications of any voltage higher than maximum rated voltages to this high impedance circuit. For proper operation, input and output voltages should be constrained to the ranges indicated in the Recommended Operating Conditions.

Maximum ratings are those values beyond which damage to the device may occur. For functional operation, voltage should be restricted to the Recommended Operating Condition.

4 Antenna/Booster Splitter Electrical Characteristics

4.1 Parameter Type

A:	100% Tested	C:	Characterized on samples
B:	100% Correlation tested	D:	Design parameter

4.2 Specification Conditions

Unless otherwise stated: $V_{cc}=5.0V$, Ambient Temperature= $25^{\circ}C$, all outputs into 75Ohm load. All specifications use a BALUN at ANT1, 2 inputs, assuming a 0.8dB MAX loss from 40MHz to 880MHz.

Table 1. Specification Conditions

Ref	Parameter	Test Conditional	Min	Typ	Max	Unit	Type
Vcc	Supply Voltage		4.5	5	5.5	V	
IccB	BST section supply current		28	35	42	mA	
	Frequency range		40		880	MHz	
GvGt	Gain	ANT1, 2 to VCRTU ANT1, 2 to TVOUT		5 5		dB	
	Gain Flatness	40 to 880MHz	-1.2		+1.2	dB	
	Noise figure	ANT1, 2 to VCRTU and ANT1, 2 to TVOUT		7	9.5	dB	
	VSWR	All pins, BST bias ON At TVout and VCRTU, BST bias OFF		1.5	2	—	
		At ANTin pins. BST OFF.		2.5	3	—	
	Intermodulation (IMD)	Input level=90dBuV See IMD Measurement	45			dBc	
	Isolation	From TVOUT or VCR to ANT1, 2 TVOUT/VCRTU from 40MHz to 600MHz ¹	45 30	50 45		dBc	

1. Output-to-Output isolation is dependant on printed circuit board (PCB) layout and Vcc line DC-coupling. See Application records and PCB layout proposal.

4.3 Intermodulation (IMD) Measurement

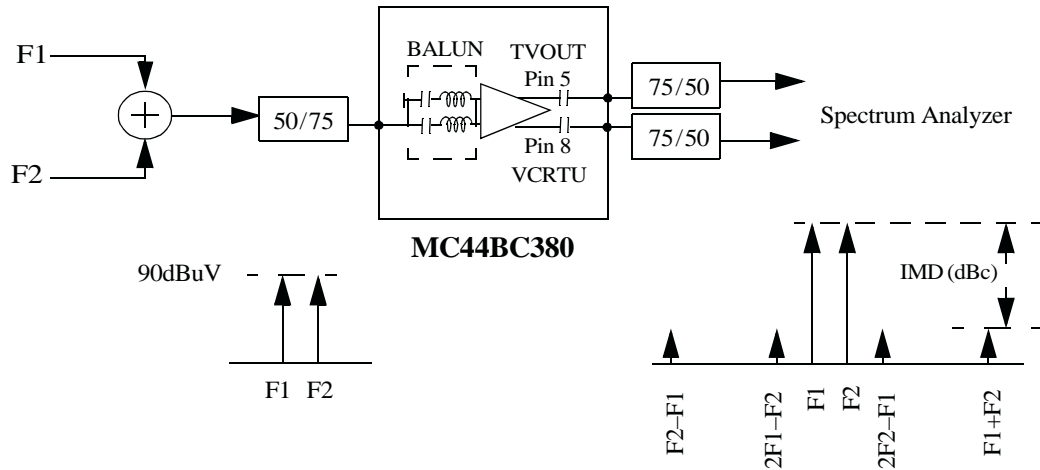

Intermodulation frequencies are all frequency combinations coming from the two input carriers F1 and F2: $F2-F1$, $2 * F1-F2$, $2 * F2-F1$ and $F1+F2$, falling into the 40Mhz to 900Mhz range.

Intermodulation (IMD) measurement is the difference (in dBc) between F1 or F2 level at the Output (VCRTU or TVOUT) and spurious level, for all the following cases:

F1=50Mhz and F2=60Mhz	F1=100Mhz and F2=110Mhz	F1=200Mhz and F2=210Mhz
F1=300Mhz and F2=310Mhz	F1=400Mhz and F2=410Mhz	F1=500Mhz and F2=510Mhz
F1=600Mhz and F2=610Mhz	F1=700Mhz and F2=710Mhz	F1=800Mhz and F2=810Mhz

F1 and F2 input levels are set to 90dBuV. Spurious specification is the worst case IMD measurement.

5 IC Block Diagram

5.1 Proposed Booster/Splitter Schematic

This document contains information on a new product under development.
Motorola reserves the right to change or discontinue this product without notice.

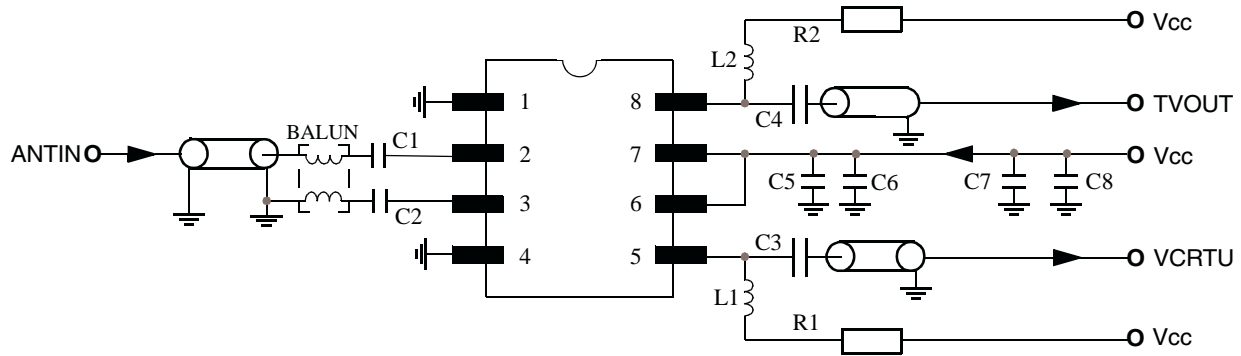

Figure 3. Proposed Booster/Splitter Schematic

5.1.1 Components

- 1nF Capacitors: C1, C2, C3, C4, C5, C6, C8
- 10nF Capacitor: C7
- Application dependant: L1, L2, R1, R2

5.1.2 Recommendations

- A BALUN is required for this application
- A single-sided PCB has been used to evaluate the device performance.
- Decoupling capacitors C5 and C6 decrease coupling between TVOUT and VCRTU through the Vcc line (bonding and PCB coupling) and increase TVOUT to VCRTU isolation (see proposed PCB layout).
- Pull-ups to Vcc may be needed on TVOUT and VCRTU pins to improve spurious performance at low Vcc (1uH in series with 75Ω).
- Resistive pull-ups can also be used to decrease gain and increase spurious performance. For example, 267 Ohms reduces gain by about 1 dB and increases IMD value by 2 to 6dB. Trade-off depends on application requirements.

6 Diagrams

6.1 Proposed Single-Sided PCB Layout

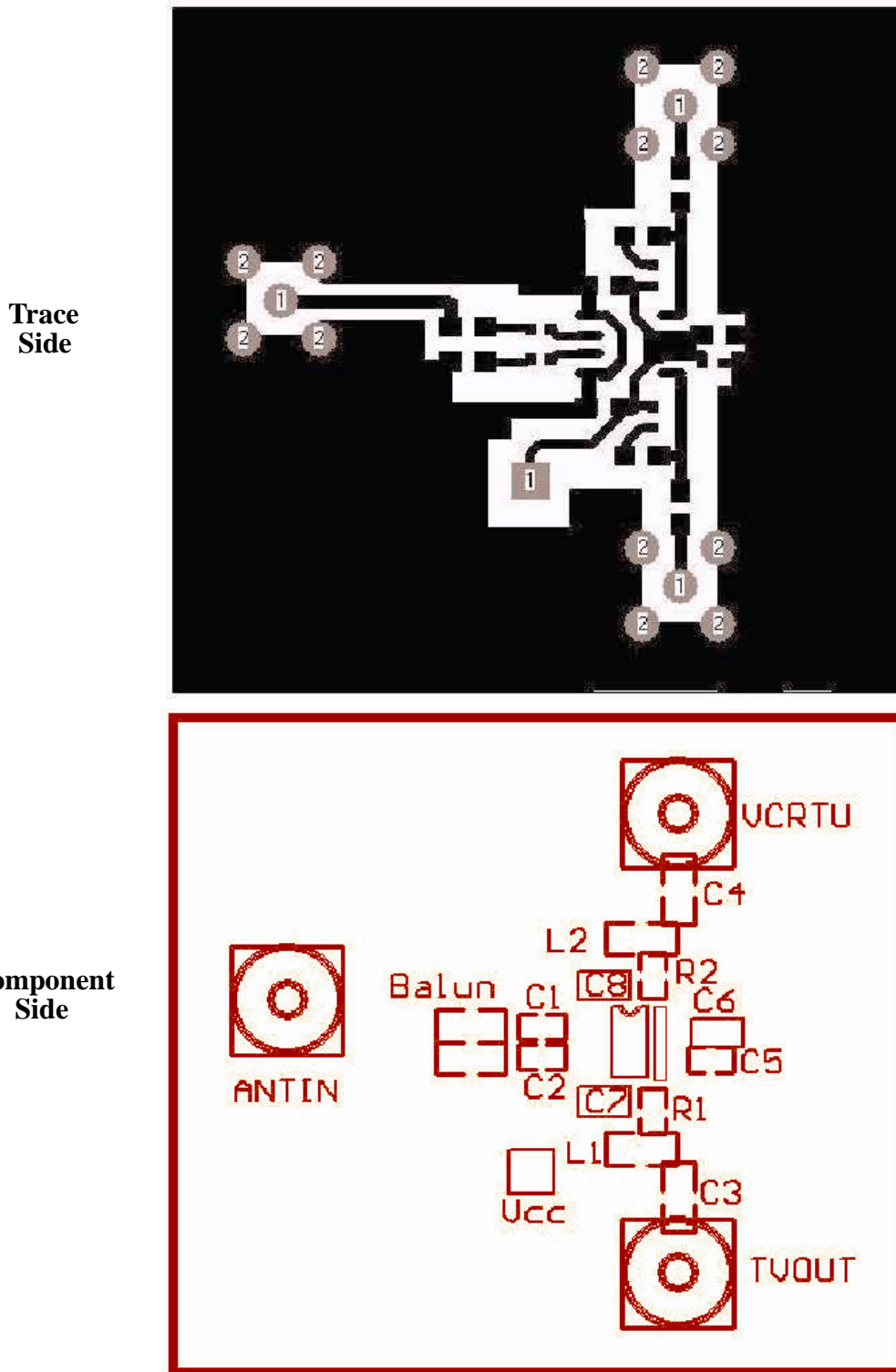
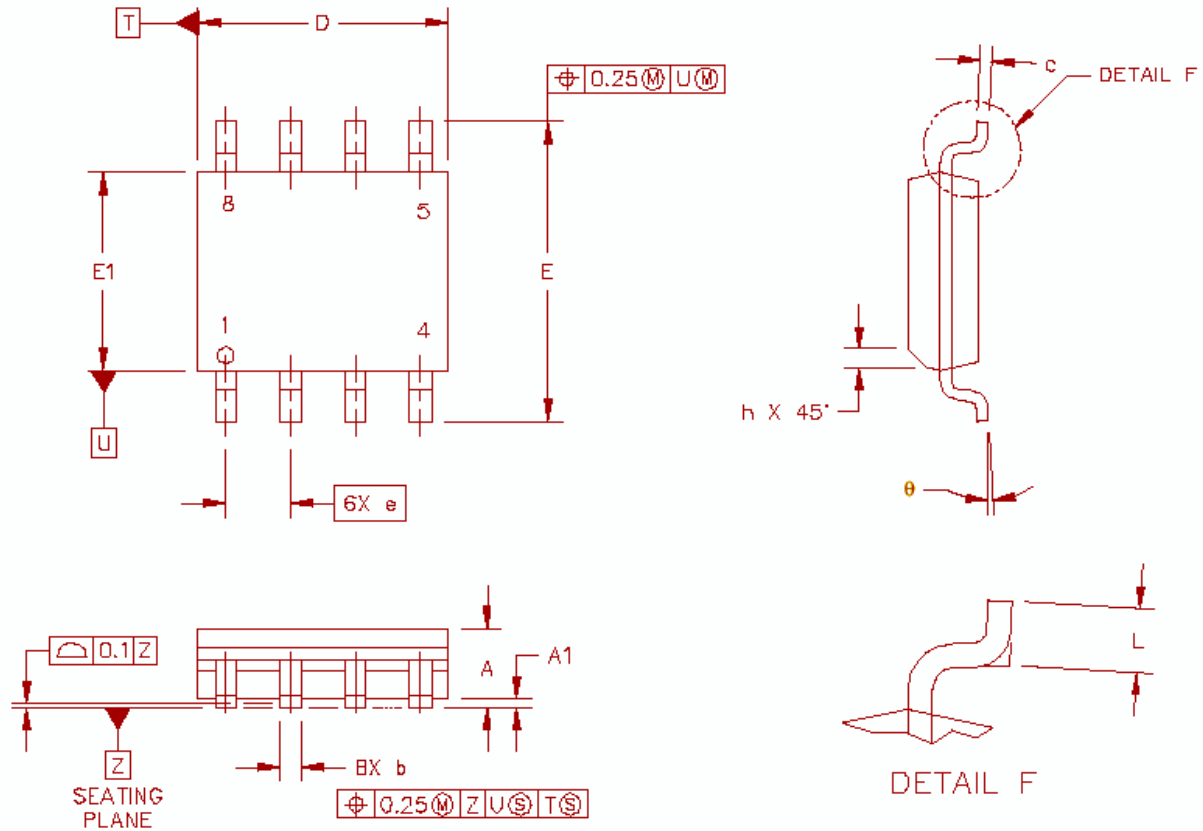

Figure 4. Proposed Single-Sided PCB Layout



LD Narrow Body—150 MIL PKG—1.27 Pitch POD

Dim	Millimeters		Inches	
	Min	Max	Min	Max
A	1.35	1.75	0.053	0.069
A1	0.1	0.25	0.003	0.010
D	4.8	5	0.188	0.197
E	5.8	6.2	0.228	0.244
E1	3.8	4	0.149	0.157
b	0.35	0.49	0.013	0.019
c	0.19	0.25	0.007	0.010
e	1.27 BSC		0.050 BSC	
h	0.25	0.5	0.009	0.020
L	0.4	1.25	0.015	0.049
Q	0°	7°	0°	7°

NOTE:

1. Dimensioning and Tolerancing per ANSI Y14.5M, 1994.
2. Controlling dimension: Millimeters.
3. Dimensions D and E1 do not include mold protrusions.
4. Maximum mold protrusion is 0.15 (0.006) per side.
5. Dimension b does not include Dambar protrusion. Allowable Dambar protrusion shall be 0.127 total in excess of b dimension at maximum material condition.

Figure 5. Diagram—SO8 Package

Freescale Semiconductor, Inc.

Home Page:

www.freescale.com

email:

support@freescale.com

USA/Europe or Locations Not Listed:

Freescale Semiconductor
Technical Information Center, CH370
1300 N. Alma School Road
Chandler, Arizona 85224
(800) 521-6274
480-768-2130

support@freescale.com

Europe, Middle East, and Africa:

Freescale Halbleiter Deutschland GmbH
Technical Information Center
Schatzbogen 7
81829 Muenchen, Germany
+44 1296 380 456 (English)
+46 8 52200080 (English)
+49 89 92103 559 (German)
+33 1 69 35 48 48 (French)

support@freescale.com

Japan:

Freescale Semiconductor Japan Ltd.
Headquarters
ARCO Tower 15F
1-8-1, Shimo-Meguro, Meguro-ku
Tokyo 153-0064, Japan
0120 191014

+81 2666 8080

support.japan@freescale.com

Asia/Pacific:

Freescale Semiconductor Hong Kong Ltd.
Technical Information Center
2 Dai King Street
Tai Po Industrial Estate,
Tai Po, N.T., Hong Kong
+800 2666 8080

support.asia@freescale.com

For Literature Requests Only:

Freescale Semiconductor
Literature Distribution Center
P.O. Box 5405
Denver, Colorado 80217
(800) 441-2447
303-675-2140
Fax: 303-675-2150
LDCForFreescaleSemiconductor
@hibbertgroup.com

RoHS-compliant and/or Pb-free versions of Freescale products have the functionality and electrical characteristics of their non-RoHS-compliant and/or non-Pb-free counterparts. For further information, see <http://www.freescale.com> or contact your Freescale sales representative.

For information on Freescale's Environmental Products program, go to <http://www.freescale.com/epp>.

Information in this document is provided solely to enable system and software implementers to use Freescale Semiconductor products. There are no express or implied copyright licenses granted hereunder to design or fabricate any integrated circuits or integrated circuits based on the information in this document. Freescale Semiconductor reserves the right to make changes without further notice to any products herein. Freescale Semiconductor makes no warranty, representation or guarantee regarding the suitability of its products for any particular purpose, nor does Freescale Semiconductor assume any liability arising out of the application or use of any product or circuit, and specifically disclaims any and all liability, including without limitation consequential or incidental damages. "Typical" parameters which may be provided in Freescale Semiconductor data sheets and/or specifications can and do vary in different applications and actual performance may vary over time. All operating parameters, including "Typicals" must be validated for each customer application by customer's technical experts. Freescale Semiconductor does not convey any license under its patent rights nor the rights of others. Freescale Semiconductor products are not designed, intended, or authorized for use as components in systems intended for surgical implant into the body, or other applications intended to support or sustain life, or for any other application in which the failure of the Freescale Semiconductor product could create a situation where personal injury or death may occur. Should Buyer purchase or use Freescale Semiconductor products for any such unintended or unauthorized application, Buyer shall indemnify and hold Freescale Semiconductor and its officers, employees, subsidiaries, affiliates, and distributors harmless against all claims, costs, damages, and expenses, and reasonable attorney fees arising out of, directly or indirectly, any claim of personal injury or death associated with such unintended or unauthorized use, even if such claim alleges that Freescale Semiconductor was negligent regarding the design or manufacture of the part.



MC44BC380/D

**For More Information On This Product,
Go to: www.freescale.com**