



# 1.4 A Dual H-Bridge Driver Compatible with 3.0 V Logic

The 34933 is a two channel H-Bridge driver aimed at the digital camera market. There are a variety of applications containing bipolar step motors and/or brush DC motors, such as Auto Focus control for the digital camera lens. The 34933 uses Freescale's proprietary SMOS8 Bi CMOS process to deliver a low power device, with a maximum quiescent current of 100  $\mu$ A for the motor drive supply and 400 $\mu$ A for the Control Logic supply.

The 34933  $V_M$  supply operates from 2.0 V to 7.0 V using an internal charge pump, with independent control of each H-Bridge driver via the MCU (IN1A, IN1B, IN2A, IN2B). The 34933 has a low total  $R_{DS(ON)}$  of 1.0  $\Omega$  (Max. at 25  $^{\circ}$ C). Shoot-through current protection is a built-in feature for the 34933 device.

The 34933 has four operation modes: Forward, Reverse, Brake, and Tri-State (High Impedance). The 34933 employs a VCC detection circuit to sense when the logic supply switches to an off-state with a maximum current of 1 $\mu$ A to extend battery life. The H-Bridge drivers can be independently pulse width modulated up to 200 kHz for speed/torque and/or current control. Note that Tri State Mode of H-Bridge drivers can occur when either VCC Detect is low or the Thermal Detect is active.

### Features

- Built-In 2-Channel H-Bridge Driver
- H-Bridge Operation Voltage 2.0 V~7.0 V
- Max. Load Output Current 1.0 A @  $T_A = 25^{\circ}$  C
- Low Total  $R_{DS(ON)}$  0.8  $\Omega$  (Typ), 1.0  $\Omega$  (Max.) @  $T_A = 25^{\circ}$  C Peak
- Dual Channel Parallel Driver,  $R_{DS(ON)}$  0.4  $\Omega$  (Typ.). Max. DC Current 1.4 A
- PWM Control Input Frequency up to 200 kHz
- Built-In Shoot-Through Current Prevention Circuit
- Built-In Charge Pump Circuit (External Cap type)
- VCC Low Voltage Detection for logic power supply voltage
- Thermal Detection for H-Bridge driver

**34933**

**H-BRIDGE DRIVER**



ORDERING INFORMATION		
Device	Temperature Range ( $T_A$ )	Package
MC34933EP/R2	-20 $^{\circ}$ C to 85 $^{\circ}$ C	16-UQFN

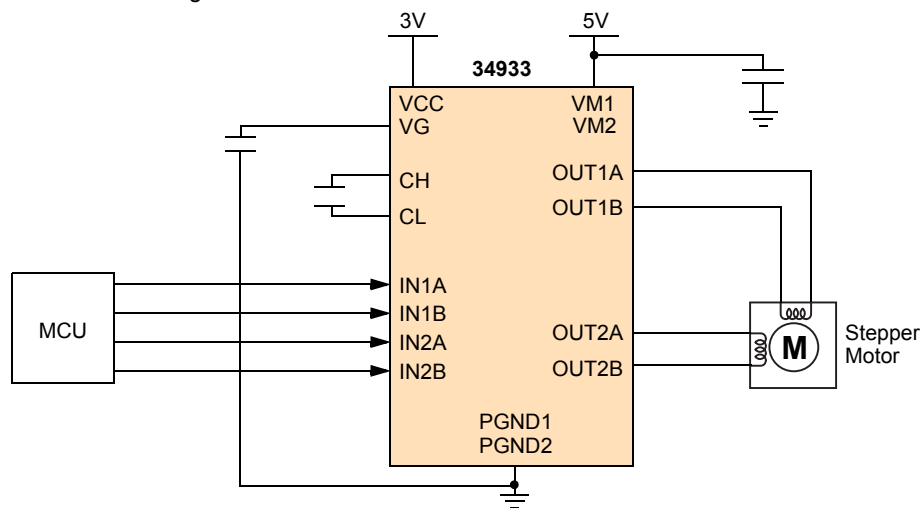
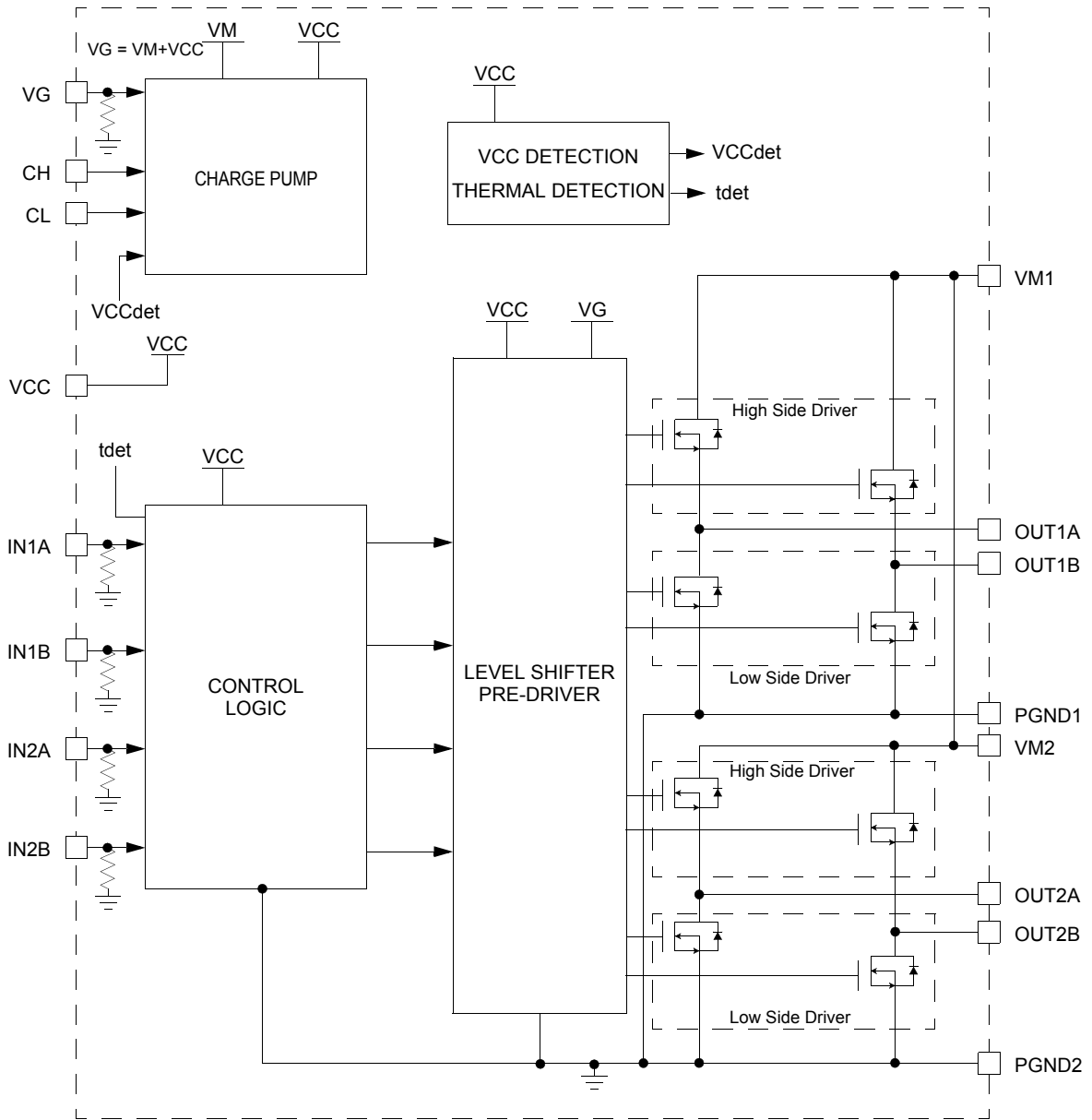

Figure 1. 34933 Simplified Application Diagram

\* This document contains certain information on a new product. Specifications and information herein are subject to change without notice.  
© Freescale Semiconductor, Inc., 2010. All rights reserved.

## INTERNAL BLOCK DIAGRAM



\* VM1 and VM2 are connected internally. Both VM1 and VM2 must be tied together on the PCB.  
 PGND1 and PGND2 are connected internally. Both PGND1 and PGND2 must be tied together on the PCB.

Figure 2. 34933 Simplified Internal Block Diagram

## PIN CONNECTIONS

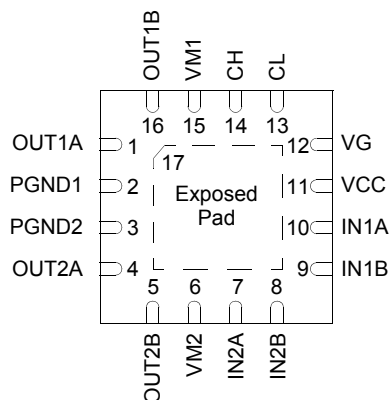

Figure 3. 34933 Pin Connections

Table 1. 34933 Pin Definitions

Pin Number	Pin Name	Pin Function	Formal Name	Definition
1	OUT1A	Output	H-Bridge output 1A	Output A of H-Bridge channel 1.
2	PGND1	Power supply	Power ground 1	Power Supply Grounds for the 34933 device. Please refer to the Application Diagram for recommended layout.
3	PGND2	Power supply	Power ground 2	Power Supply Grounds for the 34933 device. Please refer to the Application Diagram for recommended layout.
4	OUT2A	Output	H-Bridge output 2A	Output A of H-Bridge channel 2
5	OUT2B	Output	H-Bridge output 2B	Output B of H-Bridge channel 2
6	VM2	Power supply	Motor drive power supply 2	Power Supply pins for the 34933 Motor Drive circuitry. Please refer to the Application diagram for recommended layout.
7	IN2A	Input	Logic input control 2A	Logic input control of OUT2A
8	IN2B	Input	Logic input control 2B	Logic input control of OUT2B
9	IN1B	Input	Logic input control 1B	Logic input control of OUT1B
10	IN1A	Input	Logic input control 1A	Logic input control of OUT1A
11	VCC	Power supply	Control logic power supply	Power Supply for the Control Logic circuitry.
12	VG	Output	Charge pump output capacitor	Charge Pump Output pin connected to an external capacitor. Note the VG voltage is the sum of the VCC and VM power supplies.
13	CL	Input/Output	Charge pump capacitor 1	Low side Charge Pump capacitor connection
14	CH	Input/Output	Charge pump capacitor 2	High side Charge Pump capacitor connection
15	VM1	Power supply	Motor drive power supply 1	Power Supply pins for the 34933 Motor Drive circuitry. Please refer to the Application diagram for recommended layout.
16	OUT1B	Output	H-Bridge output 1B	Output B of H-Bridge channel 1
17 <sup>(1)</sup>	Exposed Pad	Power supply	EP	The Exposed Pad is connected to Ground plane via the Exposed Pad solder pad. Note the primary purpose of the Exposed pad for 34933 is thermal heat dissipation. Therefore, adequate thermal vias should be included in the PCB design.

## Notes

- Exposed pad is used as a heat sink. Connect it to the power ground through four thermal vias where the area is wide.

## ELECTRICAL CHARACTERISTICS

### MAXIMUM RATINGS

**Table 2. Maximum Ratings**

All voltages are with respect to ground unless otherwise noted. Exceeding these ratings may cause a malfunction or permanent damage to the device.

Ratings	Symbol	Value	Unit
<b>ELECTRICAL RATINGS</b>			
Control Logic Power Supply Voltage	VCC	-0.5 to +6.0	V
Motor Drive Power Supply	VM	-0.5 to +7.5	V
VCC Level Terminal Voltage - IN1A, IN1B, IN2A, IN2B	Vterminal1	-0.5 to +5.5	V
VM Level Terminal Voltage - OUT1A, OUT1B, OUT2A, OUT2B, CL	Vterminal2	-0.5 to +7.5	V
VM+VCC Level Terminal Voltage - CH, VG	Vterminal3	-0.5 to +13.5	V
Motor Drive Maximum Load Current, T <sub>A</sub> = 85 °C	Iload_dc_MD	0.7	A
Motor Drive Maximum Load Current, T <sub>A</sub> = 25 °C	Iload_dc_MD	1.0	A
Motor Drive Maximum Peak Load Current <sup>(3)</sup>	Iload_peak_MD	1.4	A
Power Dissipation <sup>(4)</sup>	PD	1.0	W
ESD Voltage <sup>(2)</sup>	V <sub>ESD</sub>		V
Human Body Model (HBM)		±4000	
Machine Model (MM)		±350	
Charge Device Model (CDM)		±1000	
<b>THERMAL RATINGS</b>			
Operating Temperature Range	T <sub>A</sub>	-20 to +85	°C
Operating Junction Temperature	T <sub>J</sub>	150	°C
Storage Temperature Range	T <sub>stg</sub>	-65 to +150	°C
<b>THERMAL RESISTANCE</b>			
Thermal Resistance, Junction to Case <sup>(5)</sup>	R <sub>θJC</sub>	23	°C/W
Peak Package Reflow Temperature During Reflow <sup>(6), (7)</sup>	T <sub>PPRT</sub>	Note 7	°C

**Notes**

2. ESD testing is performed in accordance with the Human Body Model (HBM) (CZAP = 100 pF, RZAP = 1500 W), the Machine Model (MM) (CZAP = 200 pF, RZAP = 0 W), and the Charge Device Model (CDM), Robotic (CZAP = 4.0 pF).
3. Peak time is for 10ms pulse width at 200ms intervals. T<sub>A</sub> = 25°C.
4. R<sub>θJA</sub> = 50 °C/W, in case of 2s2p printed-circuit board that defined on SEMI JEDEC JESD51- 3 and JESD51-6.
5. Thermal resistance between the die and the case top surface as measured by the cold plate method (MIL SPEC-883 Method 1012.1).
6. Pin soldering temperature limit is for 10 seconds maximum duration. Not designed for immersion soldering. Exceeding these limits may cause malfunction or permanent damage to the device.
7. Freescale's Package Reflow capability meets Pb-free requirements for JEDEC standard J-STD-020C. For Peak Package Reflow Temperature and Moisture Sensitivity Levels (MSL), go to [www.freescale.com](http://www.freescale.com), search by part number [e.g. remove prefixes/suffixes and enter the core ID to view all orderable parts. (i.e. MC33xxxD enter 33xxx), and review parametrics.

**STATIC AND DYNAMIC ELECTRICAL CHARACTERISTICS**

**Table 3. Static and Dynamic Electrical Characteristics**

Characteristics noted under conditions,  $V_M = 5.0\text{ V}$ ,  $V_{CC} = 3.0\text{ V}$ , unless otherwise noted. Typical values noted reflect the approximate parameter means at  $T_A = 25\text{ }^\circ\text{C}$  under nominal conditions, unless otherwise noted.

Characteristic	Symbol	Min	Typ	Max	Unit
<b>POWER SUPPLY</b>					
Motor Drive Power Supply Voltage	$V_M$	2.0	5.0	7.0	V
Control Logic Power Supply Voltage	$V_{CC}$	2.7	3.0	5.5	V
Driver Quiescent Supply Current (IN1A, IN1B, IN2A, IN2B = L) No Signal Input	$I_{QM}$	-	72	100	$\mu\text{A}$
Logic Quiescent Supply Current (IN1A, IN1B, IN2A, IN2B = L) No Signal Input	$I_{QVCC}$	-	114	400	$\mu\text{A}$
Control Logic Power Supply Operating Current (IN1A, IN2A = L, IN1B, IN2B = 200kHz)	$I_{VCC}$	-	350	800	$\mu\text{A}$
Charge Pump Target Voltage $V_M = 2.0\text{ V}$ , $V_{CC} = 2.7\text{ V}$ , $I_{LOAD} = 0\text{ A}$ $V_M = 5.0\text{ V}$ , $V_{CC} = 3.0\text{ V}$ , $I_{LOAD} = 0\text{ A}$ $V_M = 7.0\text{ V}$ , $V_{CC} = 5.5\text{ V}$ , $I_{LOAD} = 0\text{ A}$	$V_G$	4.2 7.6 12.0	4.45 7.8 12.3	4.7 8.0 12.5	V
Charge Pump Wake Up Time Charge pump is enabled in $V_{CC} > V_{CCDET}$	$T_{VGON}$		130	400	$\mu\text{s}$
Driver Quiescent Supply Current at $V_{CCDET} = L$ $V_M = 5.0\text{ V}$ , $V_{CC} = 0\text{ V}$	$I_{QM\_VCD=L}$	-	-	1.0	$\mu\text{A}$
Charge Pump Switching Frequency	$F_{QP}$	-	150	-	KHz
<b>H-BRIDGE DRIVER</b>					
H-Bridge Driver High/Low Side Driver On-Resistance 1 $V_{CC} = 2.7\text{ V}$ , $I_{sink} = 100\text{ mA}$ , $T_A = 25\text{ }^\circ\text{C}$	$R_{on1}$	-	0.4	0.45	$\Omega$
H-Bridge Driver High/Low Side Driver On-Resistance 2 <sup>(8)</sup> $V_{CC} = 2.7\text{ V}$ , $I_{sink} = 700\text{ mA}$ , $T_A = 25\text{ }^\circ\text{C}$	$R_{on2}$	-	0.43	0.51	$\Omega$
H-Bridge Driver High/Low Side Driver On-Resistance 3 <sup>(8)</sup> $V_{CC} = 2.7\text{ V}$ , $I_{sink} = 700\text{ mA}$ , $T_A = 85\text{ }^\circ\text{C}$	$R_{on3}$	-	0.51	0.62	$\Omega$
H-Bridge Driver High/Low Side Driver On-Resistance 4 $V_{CC} = 3.0\text{ V}$ , $I_{sink} = 100\text{ mA}$ , $T_A = 25\text{ }^\circ\text{C}$	$R_{on4}$	-	0.39	0.43	$\Omega$
H-Bridge Driver High/Low Side Driver On-Resistance 5 <sup>(8)</sup> $V_{CC} = 3.0\text{ V}$ , $I_{sink} = 700\text{ mA}$ , $T_A = 25\text{ }^\circ\text{C}$	$R_{on5}$	-	0.41	0.48	$\Omega$
H-Bridge Driver High/Low Side Driver On-Resistance 6 <sup>(8)</sup> $V_{CC} = 3.0\text{ V}$ , $I_{sink} = 700\text{ mA}$ , $T_A = 85\text{ }^\circ\text{C}$	$R_{on6}$	-	0.49	0.58	$\Omega$
H-Bridge Driver Output Body Diode Forward Voltage $I_f = 100\text{ mA}$	$V_f$	-	0.8	1.2	V
Input Pulse Frequency (INA/B) Duty of input signal = 50 %	$F_{IN}$	-	-	200	KHz

Notes

8. Guaranteed by design

**Table 3. Static and Dynamic Electrical Characteristics**

Characteristics noted under conditions,  $V_M = 5.0\text{ V}$ ,  $V_{CC} = 3.0\text{ V}$ , unless otherwise noted. Typical values noted reflect the approximate parameter means at  $T_A = 25\text{ }^\circ\text{C}$  under nominal conditions, unless otherwise noted.

H-Bridge Output Propagation Delay Time for OUTA/B (H to L) Rload = (1 k $\Omega$ ) between OUTA and OUTB (refer to <a href="#">Figure 4</a> ) (IN1A, IN2A = L, IN1B, IN2B = 200 kHz)	$t_{PDHL}$	-	0.1	0.5	us
---	------------	---	-----	-----	----

**H-BRIDGE DRIVER (CONTINUED)**

H-Bridge Output Propagation Delay Time for OUTA/B (L to H) Rload = (1k $\Omega$ ) between OUTA and OUTB (refer to <a href="#">Figure 4</a> ) (IN1A, IN2A = L, IN1B, IN2B = 200 kHz)	$t_{PDLH}$	-	0.1	0.5	us
H-Bridge Output Pulse Width Rload = 20 $\Omega$ between OUTA and OUTB, Input Pulse Width = 1.0us, 50% to 50%, $t_{PW}$ : 50% to 50% (refer to <a href="#">Figure 5</a> )	$t_{PW}$	0.7	-	-	us
H-Bridge Output Propagation Delay Time (Hi-Z to H) <sup>(8)</sup> Rload = 100 k $\Omega$ to 1/2*VM, Cload = 0 pF, $t_{PDZH}$ 50% to 75%	$t_{PDZH}$	-	-	0.5	us
H-Bridge Output Propagation Delay- Time (H to Hi-Z) <sup>(8)</sup> Rload = 100 k $\Omega$ to 1/2*VM, Cload = 0 pF, $t_{PDHZ}$ 75% to 50%	$t_{PDHZ}$	-	-	2.0	us

**CONTROL LOGIC**

High Level Input Voltage (IN1A, IN1B, IN2A, IN2B) Vcc = 2.7 V ~ 5.5 V	$V_{IH}$	$V_{CC} \times 0.7$	-	-	V
Low Level Input Voltage (IN1A, IN1B, IN2A, IN2B) Vcc = 2.7 V ~ 5.5 V	$V_{IL}$	-	-	$V_{CC} \times 0.3$	V
High Level Input Current (IN1A, IN1B, IN2A, IN2B) Vterminal1 = 3.0 V	$I_{IH}$	9	-	20	uA
Low Level Input Current (IN1A, IN1B, IN2A, IN2B) Vcc = 2.7 V ~ 5.5 V	$I_{IL}$	-1.0	-	-	uA
Input Pulse Rise Time (IN1A, IN1B, IN2A, IN2B) Vcc = 2.7 V ~ 5.5 V	tr	-	-	1.0	us
Input Pulse Fall Time (IN1A, IN1B, IN2A, IN2B) Vcc = 2.7 V ~ 5.5 V	tf	-	-	1.0	us

**DETECTOR**

VCC Detection Voltage (refer to <a href="#">Figure 6</a> )	Vccdet	2.0	2.2	2.4	V
VCC Detection hysteresis Voltage (refer to <a href="#">Figure 6</a> )	Vccdehys	0.05	0.1	0.3	V
Thermal Detection Temperature <sup>(9)</sup>	Tdet	150	170	190	°C
Thermal Detection Hysteresis Temperature <sup>(9)</sup>	Tdehys	10	20	30	°C

Notes

9. Guaranteed by design

**TIMING DIAGRAMS**

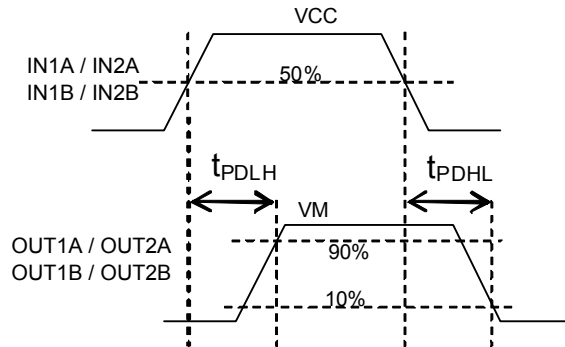

**Figure 4.  $t_{PDLH}$  and  $t_{PDHL}$  Timing**

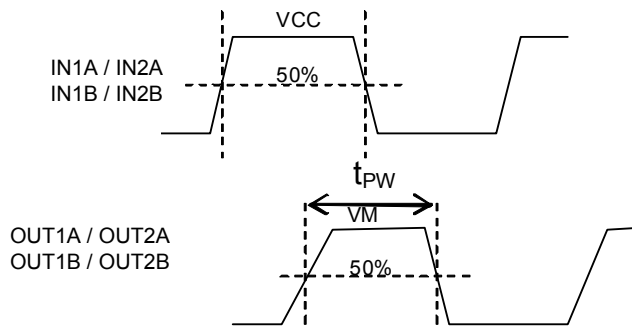

**Figure 5.  $t_{PW}$  Timing**

**Table 4. Truth Table**

Vccdet	Tdet	INPUT		OUTPUT	
		IN1A IN2A	IN1B IN2B	OUT1A OUT2A	OUT1B OUT2B
L	X	X	X	Z	Z
H	L	L	L	L	L
H	L	H	L	H	L
H	L	L	H	L	H
H	L	H	H	Z	Z
H	H	X	X	Z	Z

H - High  
L - Low  
Z - High Impedance  
X - Don't Care

Figure 6 and Figure 7 show the timing charts of input and output signals

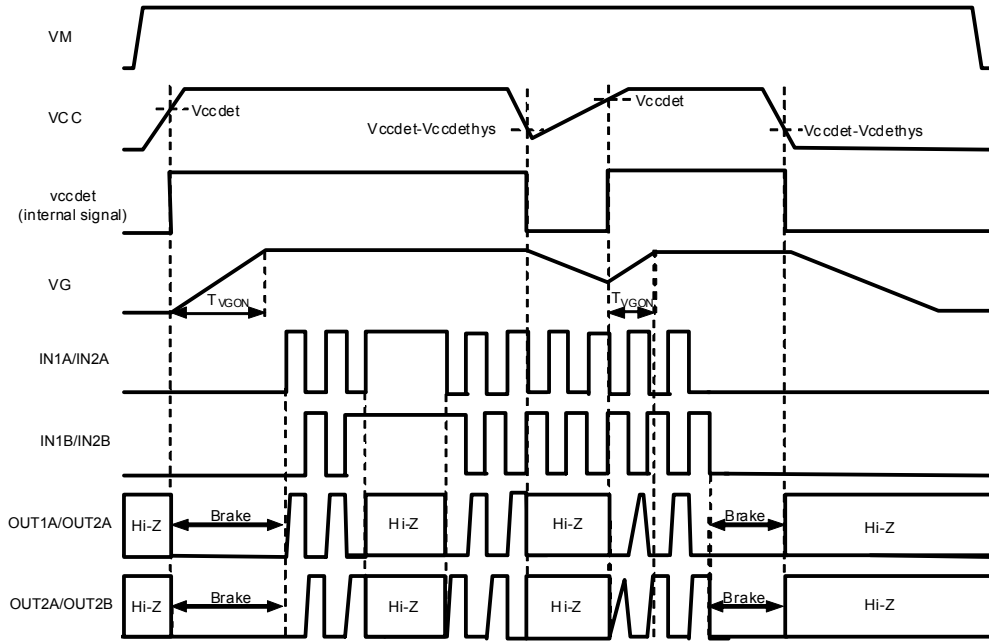

Figure 6. Timing chart of input and output signal (Vccdet case)

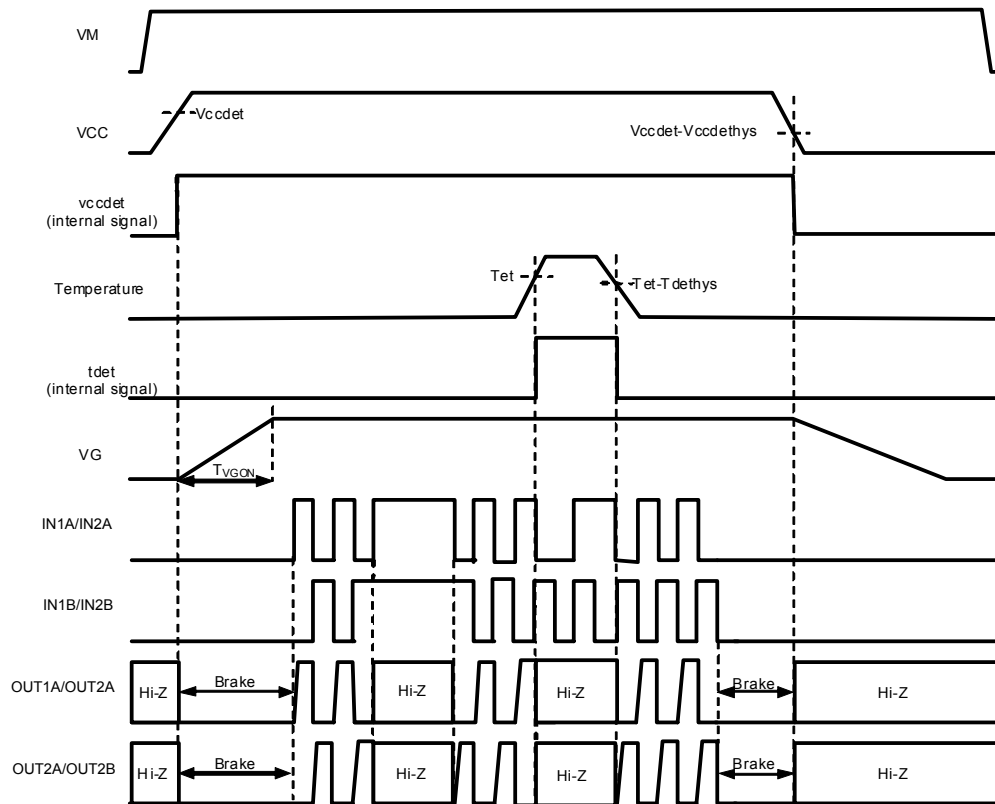

Figure 7. Timing chart of input and output signal (Tdet case)

## FUNCTIONAL DESCRIPTION

### FUNCTIONAL PIN DESCRIPTION

#### LOGIC SUPPLY (VCC)

The VCC terminal carries the logic supply voltage and current into the logic sections of the IC. VCC has an under-voltage threshold. If the supply voltage drops below the under-voltage threshold, the output power stage switches to a tri-state condition. When the supply voltage returns to a level that is above the threshold, the power stage automatically resumes normal operation according to the established condition of the input terminals.

#### LOGIC INPUT CONTROL (IN1A, IN1B, IN2A, AND IN2B)

These logic input terminals control each H-Bridge output. IN1A logic HIGH = OUT1A HIGH. However, if all inputs are HIGH, the output bridges are both tri-stated (refer to [Table 4](#), Truth Table).

#### H-BRIDGE OUTPUT (OUT1A, OUT1B, OUT2A, AND OUT2B)

These terminals provide connection to the outputs of each of the internal H-Bridges (See [Figure 2](#), 34933 Simplified Internal Block Diagram).

#### MOTOR DRIVE POWER SUPPLY (VM1 AND VM2)

The VM terminals carry the main supply voltage and current into the power sections of the IC. This supply then becomes controlled and/or modulated by the IC as it delivers the power to the loads attached between the output terminals. All VM terminals must be connected together on the Printed Circuit Board (PCB).

#### CHARGE PUMP (CL AND CH)

These two terminals, the CL and CH, connect to the external bucket capacitors required by the internal charge pump. The typical value for the bucket capacitors is 0.1  $\mu$ F.

#### POWER GROUND (PGND)

Power ground terminals must be tied together on the PCB and connected to the common ground plane.

#### LOGIC GROUND (EXPOSED PAD)

The Exposed Pad is connected to the PCB Ground plane through vias by soldering. Note the primary purpose of the Exposed pad for 34933 is thermal heat dissipation. Therefore, adequate thermal vias should be included in the PCB design. The exposed pad should be connected to the common ground plane.

### VOLTAGE DETECTION AND THERMAL LIMIT DETECTION

The 34933 has the VCC Low Voltage Detection (Vccdet) and the Thermal Detection (Tdet). VCC Low Voltage Detection is designed to shutdown of IC functions when VCC becomes lower than specified voltage. Thermal Detection operates when the IC temperature exceeds specified value

and stop H-Bridge operation. [Table 5](#) shows block status of 34933 by each condition. VCC is the control logic power supply for 34933. The system begins to operate when  $VCC > Vccdet$  (Typ. 2.2 V).

**Table 5. Block Status**

Operation mode	Vccdet	Tdet	Charge Pump	H-Bridge Driver
1	L	X	Disable	Disable
2	H	L	Enable	Enable
3	H	H	Enable	Disable

H - High  
 L - Low  
 X - Don't Care

## TYPICAL APPLICATION

Figure 8 shows a typical application using the 34933. The internal charge pump of this device is powered from the VCC supply. Therefore, care must be taken to ensure VCC is a high enough value to provide sufficient gate-source voltage for the high-side MOSFETs when  $V_M > V_{CC}$  (e.g.,  $V_M = 5.0\text{ V}$ ,  $V_{CC} = 3.0\text{ V}$ ), in order to ensure full enhancement of the high-side MOSFET channels.

The 34933 can be configured in several applications. The figure below shows the 34933 in a typical Slave Node Application.

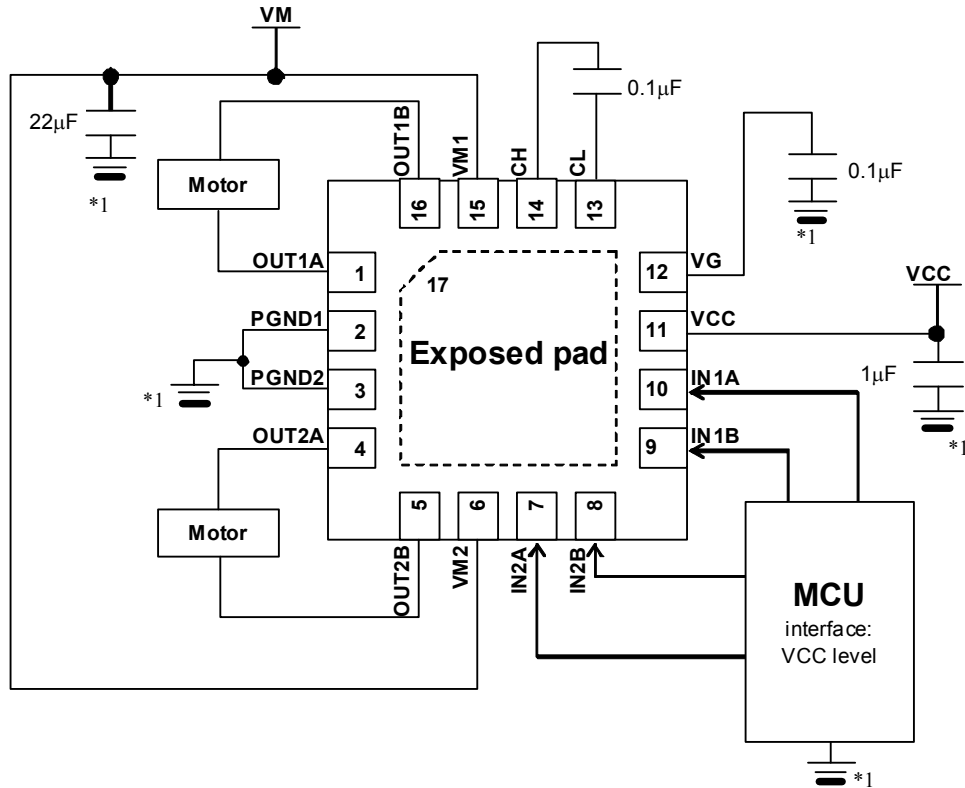

\*1 - It is recommended to use low resistance copper PCB traces between VM & VCC ground and the PGND1/PGND2 pins.

Figure 8. Typical Application

## PCB LAYOUT

When designing a printed circuit board (PCB), connect sufficient capacitance between power supplies (VM & VCC) and ground terminals to ensure proper filtering from transients. For all high-current paths, use wide copper traces and the shortest possible distances. Note, capacitors should be placed as close to the 34933 as possible to maximize the filtering capability of each capacitor.

Additionally, care must be taken to avoid CEMF spikes induced when inductive currents accumulate at the VM supply. The typical method of snubbing inductive spikes includes connecting a Zener diode or capacitor at the supply terminal (VM).

# PACKAGING

## PACKAGE DIMENSIONS

**Important:** The package information is shown below. For the latest revision, please visit [www.Freescale.com](http://www.Freescale.com).

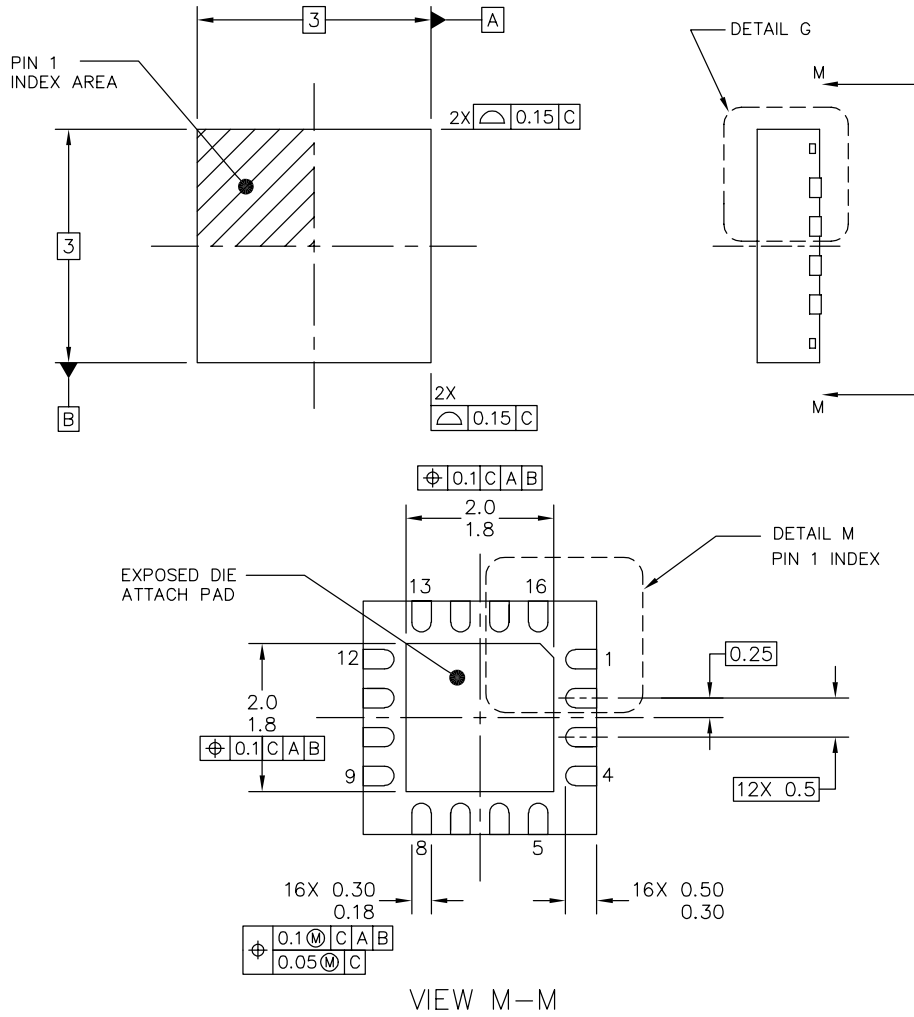

© FREESCALE SEMICONDUCTOR, INC. ALL RIGHTS RESERVED.	<b>MECHANICAL OUTLINE</b>	PRINT VERSION NOT TO SCALE
TITLE: THERMALLY ENHANCED ULTRA THIN QUAD FLAT NON-LEADED PACKAGE (UQFN), 16 TERMINAL, 0.5 PITCH, 3 X 3 X 0.65 PKG, TYPE-E LEAD	DOCUMENT NO: 98ASA00110D	REV: 0
	CASE NUMBER: 2096-01	31 JUL 2009
STANDARD: NON-JEDEC		

**EP SUFFIX (PB-FREE)**  
16-PIN UQFN  
98ASA00110D  
REVISION O

**PACKAGE DIMENSIONS (Continued)**

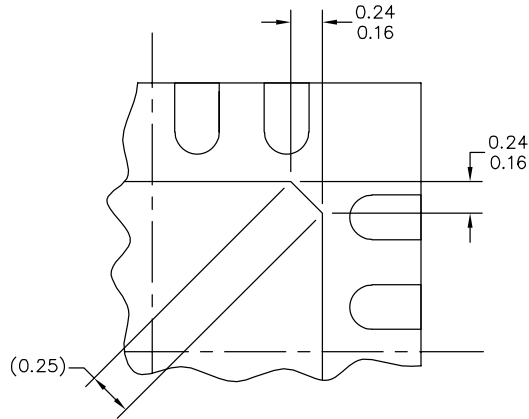

DETAIL M  
PIN 1 BACKSIDE IDENTIFIER

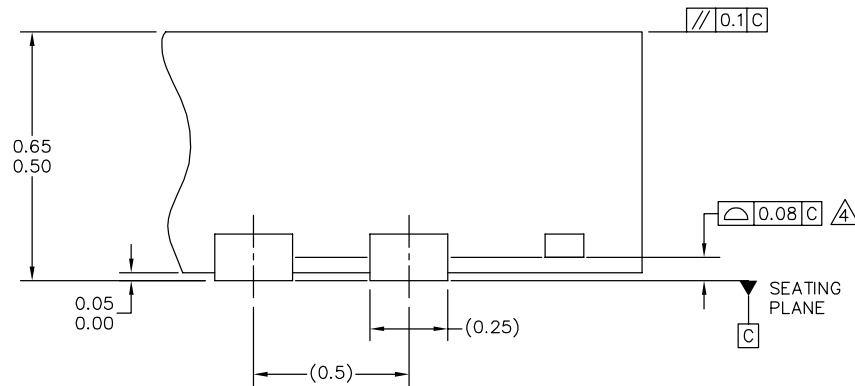

DETAIL G  
VIEW ROTATED 90° CW

© FREESCALE SEMICONDUCTOR, INC. ALL RIGHTS RESERVED.	<b>MECHANICAL OUTLINE</b>	PRINT VERSION NOT TO SCALE	
TITLE: THERMALLY ENHANCED ULTRA THIN QUAD FLAT NON-LEADED PACKAGE (UQFN), 16 TERMINAL, 0.5 PITCH, 3 X 3 X 0.65 PKG, TYPE-E LEAD	DOCUMENT NO: 98ASA00110D	REV: 0	
	CASE NUMBER: 2096-01	31 JUL 2009	
	STANDARD: NON-JEDEC		

**EP SUFFIX (PB-FREE)**  
16-PIN UQFN  
98ASA00110D  
REVISION 0

**PACKAGE DIMENSIONS (Continued)**

NOTES:

1. ALL DIMENSIONS ARE IN MILLIMETERS.
2. DIMENSIONING AND TOLERANCING PER ASME Y14.5M-1994.
3. THE COMPLETE JEDEC DESIGNATOR FOR THIS PACKAGE IS: HF-PQFN.
4.  COPLANARITY APPLIES TO LEADS AND DIE ATTACH PAD.

© FREESCALE SEMICONDUCTOR, INC. ALL RIGHTS RESERVED.	<b>MECHANICAL OUTLINE</b>	PRINT VERSION NOT TO SCALE	
TITLE: THERMALLY ENHANCED ULTRA THIN QUAD FLAT NON-LEADED PACKAGE (UQFN), 16 TERMINAL, 0.5 PITCH, 3 X 3 X 0.65 PKG, TYPE-E LEAD	DOCUMENT NO: 98ASA00110D	REV: 0	
	CASE NUMBER: 2096-01	31 JUL 2009	
	STANDARD: NON-JEDEC		

**EP SUFFIX (PB-FREE)**  
 16-PIN UQFN  
 98ASA00110D  
 REVISION 0

## REVISION HISTORY

REVISION	DATE	DESCRIPTION OF CHANGES
2.0	7/2010	<ul style="list-style-type: none"><li>Initial Release.</li></ul>

## **How to Reach Us:**

### **Home Page:**

[www.freescale.com](http://www.freescale.com)

### **Web Support:**

<http://www.freescale.com/support>

### **USA/Europe or Locations Not Listed:**

Freescale Semiconductor, Inc.  
Technical Information Center, EL516  
2100 East Elliot Road  
Tempe, Arizona 85284  
1-800-521-6274 or +1-480-768-2130  
[www.freescale.com/support](http://www.freescale.com/support)

### **Europe, Middle East, and Africa:**

Freescale Halbleiter Deutschland GmbH  
Technical Information Center  
Schatzbogen 7  
81829 Muenchen, Germany  
+44 1296 380 456 (English)  
+46 8 52200080 (English)  
+49 89 92103 559 (German)  
+33 1 69 35 48 48 (French)  
[www.freescale.com/support](http://www.freescale.com/support)

### **Japan:**

Freescale Semiconductor Japan Ltd.  
Headquarters  
ARCO Tower 15F  
1-8-1, Shimo-Meguro, Meguro-ku,  
Tokyo 153-0064  
Japan  
0120 191014 or +81 3 5437 9125  
[support.japan@freescale.com](mailto:support.japan@freescale.com)

### **Asia/Pacific:**

Freescale Semiconductor China Ltd.  
Exchange Building 23F  
No. 118 Jianguo Road  
Chaoyang District  
Beijing 100022  
China  
+86 10 5879 8000  
[support.asia@freescale.com](mailto:support.asia@freescale.com)

### **For Literature Requests Only:**

Freescale Semiconductor Literature Distribution Center  
P.O. Box 5405  
Denver, Colorado 80217  
1-800-441-2447 or +1-303-675-2140  
Fax: +1-303-675-2150  
[LDCForFreescaleSemiconductor@hibbertgroup.com](mailto:LDCForFreescaleSemiconductor@hibbertgroup.com)

Information in this document is provided solely to enable system and software implementers to use Freescale Semiconductor products. There are no express or implied copyright licenses granted hereunder to design or fabricate any integrated circuits or integrated circuits based on the information in this document.

Freescale Semiconductor reserves the right to make changes without further notice to any products herein. Freescale Semiconductor makes no warranty, representation or guarantee regarding the suitability of its products for any particular purpose, nor does Freescale Semiconductor assume any liability arising out of the application or use of any product or circuit, and specifically disclaims any and all liability, including without limitation consequential or incidental damages. "Typical" parameters that may be provided in Freescale Semiconductor data sheets and/or specifications can and do vary in different applications and actual performance may vary over time. All operating parameters, including "Typicals", must be validated for each customer application by customer's technical experts. Freescale Semiconductor does not convey any license under its patent rights nor the rights of others. Freescale Semiconductor products are not designed, intended, or authorized for use as components in systems intended for surgical implant into the body, or other applications intended to support or sustain life, or for any other application in which the failure of the Freescale Semiconductor product could create a situation where personal injury or death may occur. Should Buyer purchase or use Freescale Semiconductor products for any such unintended or unauthorized application, Buyer shall indemnify and hold Freescale Semiconductor and its officers, employees, subsidiaries, affiliates, and distributors harmless against all claims, costs, damages, and expenses, and reasonable attorney fees arising out of, directly or indirectly, any claim of personal injury or death associated with such unintended or unauthorized use, even if such claim alleges that Freescale Semiconductor was negligent regarding the design or manufacture of the part.



Freescale™ and the Freescale logo are trademarks of Freescale Semiconductor, Inc. All other product or service names are the property of their respective owners.

© Freescale Semiconductor, Inc., 2010. All rights reserved.