



# Electric Field Imaging Device

The MC33941 is intended for cost-sensitive applications where non-contact sensing of objects is desired. When connected to external electrodes, an electric field is created. The MC33941 detects objects in this electric field. The IC generates a low-frequency sine wave, which is adjustable by using an external resistor and is optimized for 120 kHz. The sine wave has very low harmonic content to reduce harmonic interference. The MC33941 also contains support circuits for a microcontroller unit (MCU) to allow the construction of a two-chip E-field system.

## Features

- Supports up to 7 Electrodes
- Shield Driver for Driving Remote Electrodes Through Coaxial
- High-Purity Sine Wave Generator Tunable with External Resistor
- Response Time Tunable with External Capacitor
- +5V Regulator to Power External Circuit
- Can support up to 28 touch pad sensors (2 way multiplexing)
- Extended Temperature Range -40° to 110°C
- Pb-Free and RoHS compliant

## Typical Applications

- Appliance Control Panels and Touch Sensors
- Linear and Rotational Sliders
- Spill Over Flow Sensing Measurement
- Refrigeration Frost Sensing
- Industrial Control and Safety Systems Security
- Proximity Detection for Wake-Up Features
- Touch Screens
- Garage Door Safety Sensing
- PC Peripherals
- Patient Monitoring
- Point of Sale Terminals
- Size Detection
- Liquid Level Sensing

**MC33941**

**ELECTRONIC FIELD  
 IMAGING DEVICE**

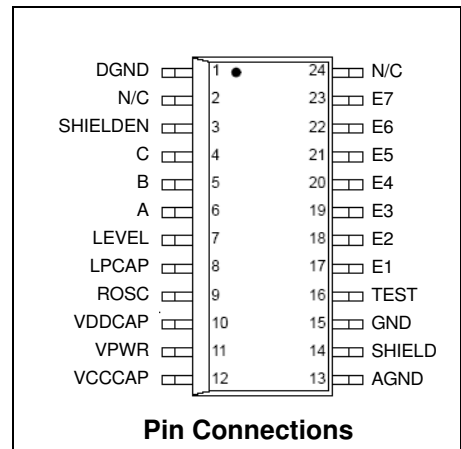

| ORDERING INFORMATION |                   |             |          |
|----------------------|-------------------|-------------|----------|
| Device Name          | Temperature Range | Drawing     | Package  |
| MC33941EG/R2         | -40° to 110°C     | 98ASB42564B | SOICW-24 |

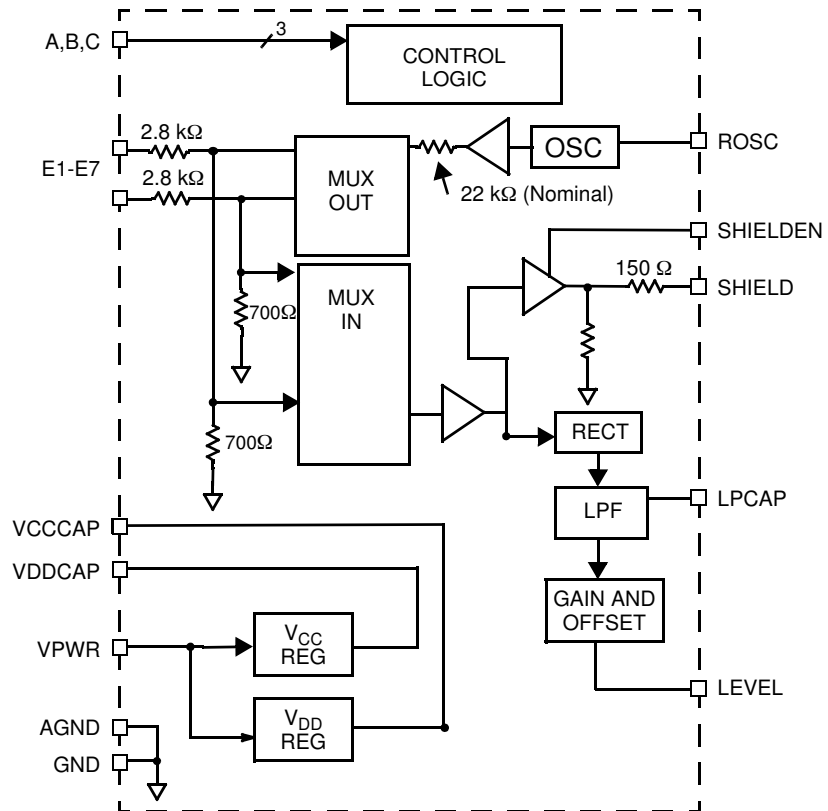

Figure 1 Simplified Functional Block Diagram

**Table 1. Maximum Ratings**

All voltages are with respect to ground unless otherwise noted. Exceeding these ratings may cause a malfunction or permanent damage to the device.

| Rating                                                                                                                                                                                                                               | Symbol                                                | Value                                 | Unit               |
|--------------------------------------------------------------------------------------------------------------------------------------------------------------------------------------------------------------------------------------|-------------------------------------------------------|---------------------------------------|--------------------|
| <b>ELECTRICAL RATINGS</b>                                                                                                                                                                                                            |                                                       |                                       |                    |
| Peak $V_{PWR}$ Voltage                                                                                                                                                                                                               | $V_{PWRPK}$                                           | 40                                    | V                  |
| Double Battery<br>1 Minute Maximum $T_A = 30^\circ\text{C}$                                                                                                                                                                          | $V_{DBLBAT}$                                          | 26.5                                  | V                  |
| ESD Voltage<br>Human Body Model ( $C_{ZAP} = 100\text{ pF}$ , $R_{ZAP} = 1500\text{ W}$ )<br>Machine Model ( $C_{ZAP} = 200\text{ pF}$ , $R_{ZAP} = 0\text{ W}$ )<br>Charge Device Model (CDM), Robotic ( $C_{ZAP} = 4.0\text{pF}$ ) | $V_{ESD}$                                             | $\pm 2000$<br>$\pm 200$<br>$\pm 1200$ | V                  |
| <b>THERMAL RATINGS</b>                                                                                                                                                                                                               |                                                       |                                       |                    |
| Storage Temperature                                                                                                                                                                                                                  | $T_{STG}$                                             | -55 to 150                            | $^\circ\text{C}$   |
| Operating Ambient Temperature                                                                                                                                                                                                        | $T_A$                                                 | -40 to 110                            | $^\circ\text{C}$   |
| Operating Junction Temperature                                                                                                                                                                                                       | $T_J$                                                 | -40 to 150                            | $^\circ\text{C}$   |
| Thermal Resistance<br>Junction-to-Ambient <sup>(1)</sup><br>Junction-to-Case <sup>(2)</sup><br>Junction-to-Board <sup>(3)</sup>                                                                                                      | $R_{\theta JA}$<br>$R_{\theta JC}$<br>$R_{\theta JB}$ | 41<br>0.2<br>3.0                      | $^\circ\text{C/W}$ |
| Soldering Temperature <sup>(4)</sup>                                                                                                                                                                                                 |                                                       |                                       |                    |

**Notes**

- Junction temperature is a function of on-chip power dissipation, package thermal resistance, mounting site (board) temperature, ambient temperature, air flow, power dissipation of other components on the board, and board thermal resistance. In accordance with SEMI G38-87 and JEDEC JESD51-2 with the single layer board horizontal.
- Indicates the average thermal resistance between the die and the case top surface as measured by the cold plate method (MILSPEC 883 Method 1012.1) with the cold plate temperature used for the case temperature.
- Thermal resistance between the die and the printed circuit board per JEDEC JESD51-8. Board temperature is measured on the top surface of the board near the package.
- Terminal soldering temperature limit is for 10 seconds maximum duration. The device is not designed for immersion soldering. Exceeding these limits may cause malfunction or permanent damage to the device.

**Table 2. Static Electrical Characteristics**

Characteristics noted under conditions  $5.5\text{ V} \leq V_{\text{SUP}} \leq 18\text{ V}$ ,  $-40^\circ\text{C} \leq T_A \leq 110^\circ\text{C}$ ,  $\text{GND} = 0\text{ V}$  unless otherwise noted. Typical values noted reflect the approximate parameter means at  $T_A = 25^\circ\text{C}$  under nominal conditions unless otherwise noted.

| Characteristic | Symbol | Min | Typ | Max | Unit |
|----------------|--------|-----|-----|-----|------|
|----------------|--------|-----|-----|-----|------|

**SUPPLY ( $V_{\text{PWR}}$ )**

|                                                                                                                                                                                      |                  |     |     |     |    |
|--------------------------------------------------------------------------------------------------------------------------------------------------------------------------------------|------------------|-----|-----|-----|----|
| Supply Voltage                                                                                                                                                                       | $V_{\text{PWR}}$ | 9.0 | 12  | 18  | V  |
| $I_{\text{DD}}$ ( $V_{\text{PWR}} = 14\text{V}$ )<br>(Quiescent supply current measured over temperature. Assumes that no external devices connected to internal voltage regulators) | $I_{\text{DD}}$  | 6.0 | 7.0 | 8.0 | mA |

**VOLTAGE REGULATOR**

|                                                                                                                                                                   |        |      |   |      |   |
|-------------------------------------------------------------------------------------------------------------------------------------------------------------------|--------|------|---|------|---|
| 5V Regulator Voltage<br>$7.0\text{ V} \leq V_{\text{PWR}} \leq 18\text{ V}$ , $1.0\text{ mA} \leq I_L \leq 75\text{ mA}$ , $\text{CFILT} = 47\text{ }\mu\text{F}$ | VCCCAP | 4.75 | 5 | 5.25 | V |
|-------------------------------------------------------------------------------------------------------------------------------------------------------------------|--------|------|---|------|---|

**ELECTRODE SIGNALS (E1–E7)**

|                                                                                                                              |                    |     |     |     |    |
|------------------------------------------------------------------------------------------------------------------------------|--------------------|-----|-----|-----|----|
| Total Variance Between Electrode Measurements <sup>(5)</sup><br>All $C_{\text{LOAD}} = 15\text{ pF}$                         | ELV <sub>VAR</sub> | –   | –   | 3.0 | %  |
| Electrode Maximum Harmonic Level Below Fundamental <sup>(5)</sup><br>$5.0\text{ pF} \leq C_{\text{LOAD}} \leq 150\text{ pF}$ | EL <sub>HARM</sub> | –   | -20 | –   | dB |
| Electrode Transmit Output Range<br>$5.0\text{ pF} \leq C_{\text{LOAD}} \leq 150\text{ pF}$                                   | EL <sub>TXV</sub>  | 1.0 | –   | 8.0 | V  |
| Receive Input Voltage Range                                                                                                  | RX <sub>V</sub>    | 0   | –   | 9.0 | V  |
| Grounding Switch on Voltage <sup>(6)</sup><br>$I_{\text{SW}} = 1.0\text{ mA}$                                                | SW <sub>VON</sub>  | –   | –   | 5.0 | V  |

**LOGIC I/O (C, B, A)**

|                                                                                  |                  |            |        |           |                 |
|----------------------------------------------------------------------------------|------------------|------------|--------|-----------|-----------------|
| CMOS Logic Input Low Threshold                                                   | $V_{\text{THL}}$ | 0.3        | –      | –         | $V_{\text{CC}}$ |
| Logic Input High Threshold                                                       | $V_{\text{THH}}$ | –          | –      | 0.7       | $V_{\text{CC}}$ |
| Voltage Hysteresis                                                               | $V_{\text{HYS}}$ | –          | 0.06   | –         | $V_{\text{CC}}$ |
| Input Current<br>$V_{\text{IN}} = V_{\text{CC}}$<br>$V_{\text{IN}} = 0\text{ V}$ | $I_{\text{IN}}$  | 10<br>-5.0 | –<br>– | 50<br>5.0 | $\mu\text{A}$   |

**SIGNAL DETECTOR (LPCAP)**

|                            |                     |      |      |      |                  |
|----------------------------|---------------------|------|------|------|------------------|
| Detector Output Resistance | DET <sub>RO</sub>   | –    | 50   | –    | $\text{k}\Omega$ |
| LPCAP to LEVEL Gain        | A <sub>REC</sub>    | 3.6  | 4.0  | 4.4  | $A_V$            |
| LPCAP to LEVEL Offset      | V <sub>RECOFF</sub> | -3.3 | -3.0 | -2.7 | V                |

## Notes

5. Verified by design and characterization. Not tested in production.
6. Current into grounded terminal under test = 1.0 mA.

**Table 3. Dynamic Electrical Characteristics <sup>(7)</sup>**

Characteristics noted under conditions  $5.5\text{ V} \leq V_{\text{SUP}} \leq 18\text{ V}$ ,  $-40^\circ\text{C} \leq T_A \leq 110^\circ\text{C}$ ,  $\text{GND} = 0\text{ V}$  unless otherwise noted.  
 Typical values noted reflect the approximate parameter means at  $T_A = 25^\circ\text{C}$  under nominal conditions unless otherwise noted.

| Characteristic                                                                                     | Symbol                     | Min         | Typ              | Max         | Unit |
|----------------------------------------------------------------------------------------------------|----------------------------|-------------|------------------|-------------|------|
| <b>OSC (ROSC)</b>                                                                                  |                            |             |                  |             |      |
| OSC Frequency Stability                                                                            | $f_{\text{STAB}}$          | –           | –                | 10          | %    |
| OSC Center Frequency<br>ROSC = 39 k $\Omega$<br>ROSC = 20 k $\Omega$<br>ROSC = 82 k $\Omega$       | $f_{\text{OSC}}$           | –<br>–<br>– | 120<br>240<br>60 | –<br>–<br>– | kHz  |
| Harmonic Content<br>2nd through 4th Harmonic Level<br>5th and Higher                               | $\text{OSCH}_{\text{ARM}}$ | –<br>–      | –<br>–           | -20<br>-60  | dB   |
| <b>SHIELD DRIVER (SHIELD)</b>                                                                      |                            |             |                  |             |      |
| Shield Driver Maximum Harmonic level below Fundamental<br>10 pF $\leq C_{\text{LOAD}} \leq$ 500 pF | $\text{SD}_{\text{HARM}}$  | –           | -20              | –           | dB   |
| Shield Driver Gain Bandwidth Product<br>Measured at 120 kHz                                        | $\text{SD}_{\text{GBW}}$   | –           | 4.5              | –           | MHz  |

## Notes

7. All parameters are guaranteed by design.

## PRINCIPLE OF OPERATION

The 33941 generates a low radio frequency sine wave with nominal 5.0 V peak-to-peak amplitude. The frequency is set by an external resistor and is optimized for 120 kHz. An internal multiplexer routes the signal to one of the 7 terminals under control of the ABC input terminals. A receiver multiplexer simultaneously connected to the selected electrode and routes its signal to a detector, which converts the sine wave to a DC level. The DC level is filtered by an external capacitor, is multiplied and offset to increase sensitivity. All electrode outputs are grounded internally by the device when not selected.

The amplitude and phase of the sinusoidal wave at the electrode are affected by objects in proximity. A “capacitor” is

formed between the driving electrode and the object, each forming a “plate” that holds the electric charge. The voltage measured is an inverse function of the capacitance between the electrode being measured, the surrounding electrodes, and other objects in the electric field surrounding the electrode. Increasing capacitance results in decreasing voltage. The value of the series resistor (22kohm) was chosen to provide a near linear relationship at 120 kHz over a range of 10pF to 70pF.

While exploring applications using the E-Field chip, it is always useful to approach the problem using the capacitor model.

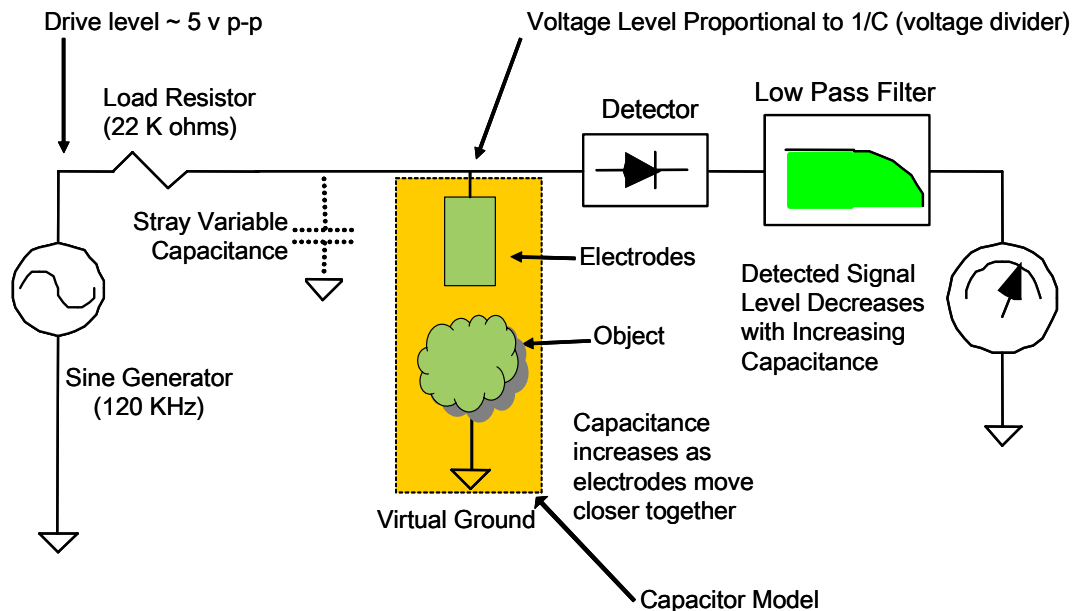
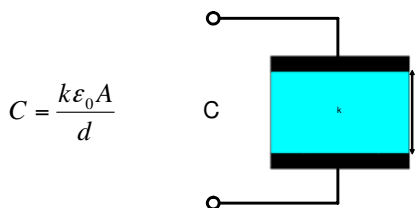

Figure 2 . Conceptual Block Diagram

### CAPACITOR MODEL

The capacitance measured by the E-Field IC is:

- Proportional to the area of the electrode
- Proportional to the dielectric constant of the material between the electrodes
- Inversely proportional to the distance between the objects



C=The Capacitance in Farads (F)  
 A=The area of the plates in square meters (m<sup>2</sup>)  
 d=The distance between the plates in meters (m)  
 k=The dielectric constant of the material separating the plates  
 0=Is the permittivity of free space (8.85 x 10<sup>-12</sup> F/m)

Figure 3. Capacitor Model

Table 4 Dielectric Constants of Various Materials

| Dielectric Material | Thickness (mil) | k       |
|---------------------|-----------------|---------|
| Acrylic             | 84.5            | 2.4-4.5 |
| Glass               | 74.5            | 7.5     |
| Nylon Plastic       | 68              | 3.0-5.0 |
| Polyester Film      | 10              | 3.2     |
| Flexible Vinyl Film | 9               | 2.8-4.5 |
| Air                 | -               | 1       |
| Water               | -               | 80      |
| Ice                 | -               | 3.2     |
| Automotive Oil      | -               | 2.1     |

## FEATURES

### SHIELD DRIVER

A shield driver is included to minimize the electrode signal along wires. This circuit provides a buffered version of the returned AC signal from the electrode. Since it has nearly the same amplitude and phase as the electrode signal, there is little or no potential difference between the two signals, thereby canceling out any electric field. In effect, the shield drive isolates the electrode signal from external virtual grounds. A common application is to connect the Shield Driver to the shield of a coax cable used to connect an electrode to the corresponding electrode terminal. Another typical use is to drive a ground plane that is used behind an array of touch sensor electrodes in order to cancel out any virtual grounds that could attenuate the AC signal.

### TUNABLE FREQUENCY

The 33941 offers 3 operating frequencies. In addition to the default frequency of 120 kHz, the 33941 has also been characterized to work in two other frequencies (240 kHz and 60 kHz) for applications with specific needs. These frequencies are tunable by attaching a 20k and 82k resistor

at ROSC respectively. If a wider capacitance range is needed, simply change the ROSC resistor value to 82k to have the signal generator operate at 60 kHz which will extend the capacitance range to 150pF as seen on [Figure 4](#). The figure also shows that one can achieve higher sensitivity at lower capacitances by setting the ROSC resistor value to 20k. All resistor values listed above are for 5% tolerance resistors.

### ADJUSTABLE RESPONSE TIME

The rectified sine wave is filtered by a Low Pass Filter formed by an internal resistor and an external capacitor attached to LP\_CAP. The value of the external capacitor is selected to allow the designer to optimize the balance between noise and settling time. A typical value for the external capacitor is 10nF and in practice it will have a response time of **1.5ms**. If faster response time is required a 1nF capacitor can be used and it will have response times **< 200μs**. Please note that reducing the LP\_CAP capacitor value increases noise accordingly.

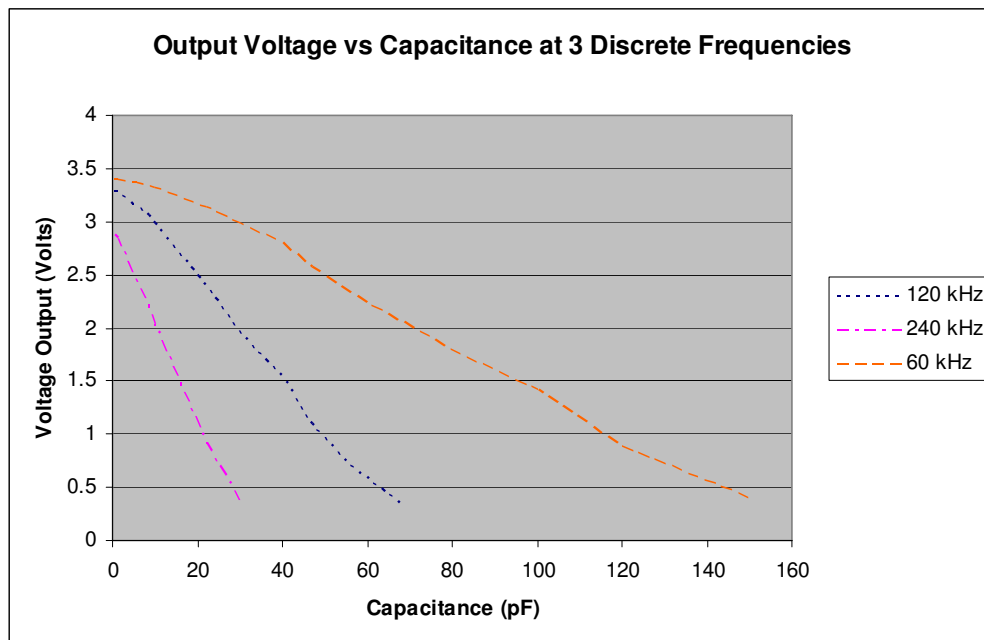
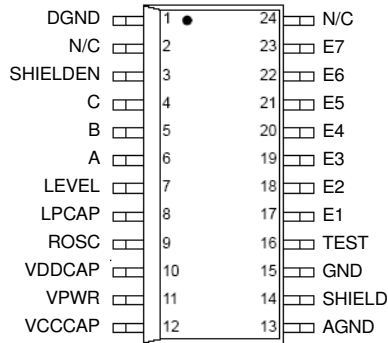

Figure 4 . Output Voltage vs. Capacitance at 3 Discrete Frequencies

## BASIC CONNECTIONS

### PIN DESCRIPTIONS



**Figure 5. Pin Descriptions**

**Table 5. Electrode Selection**

| Terminal/SIGNAL        | C | B | A |
|------------------------|---|---|---|
| No electrodes selected | 0 | 0 | 0 |
| E1                     | 0 | 0 | 1 |
| E2                     | 0 | 1 | 0 |
| E3                     | 0 | 1 | 1 |
| E4                     | 1 | 0 | 0 |
| E5                     | 1 | 0 | 1 |
| E6                     | 1 | 1 | 0 |
| E7                     | 1 | 1 | 1 |

**Table 6. Pin Description**

| Pin Number | Pin Name | Definition                                                                                                                 |
|------------|----------|----------------------------------------------------------------------------------------------------------------------------|
| 1          | DGND     | Connected to the ground return                                                                                             |
| 2, 24      | N/C      | These pins should be left open.                                                                                            |
| 3          | SHIELDEN | Used to enable the shield signal                                                                                           |
| 4,5,6      | C, B, A  | Controls electrode or reference activity                                                                                   |
| 7          | LEVEL    | This is the detected, amplified, and offset representation of the signal voltage on the selected electrode                 |
| 8          | LPCAP    | A capacitor on this pin forms a low pass filter with the internal series resistance from the detector to this pin          |
| 9          | ROSC     | A resistor from this pin to circuit ground determines the operating frequency of the oscillator                            |
| 10         | VDDCAP   | A 47 $\mu$ F capacitor is connected to this pin to filter the internal analog regulated supply                             |
| 11         | VPWR     | 12 V power applied to this pin will be converted to the internal regulated voltages needed to operate the part             |
| 12         | VCCCAP   | A 47 $\mu$ F capacitor is connected to this pin and VCCCAP provides a regulated 5.0 V to power external circuits 75 mA Max |
| 13         | AGND     | Connected to the ground return of the analog circuitry                                                                     |
| 14         | SHIELD   | Connects to cable shields to cancel cable capacitance.                                                                     |
| 15         | GND      | Main IC ground                                                                                                             |
| 16         | TEST     | Connect to circuit ground                                                                                                  |
| 17-23      | E1–E7    | Electrode pins                                                                                                             |

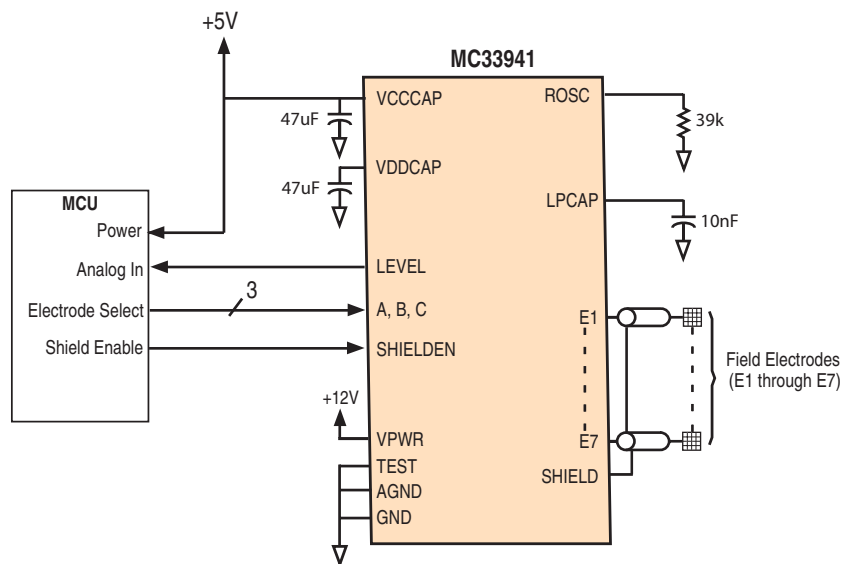

**Figure 6 . Simplified Application Diagram**

# PACKAGE DIMENSIONS

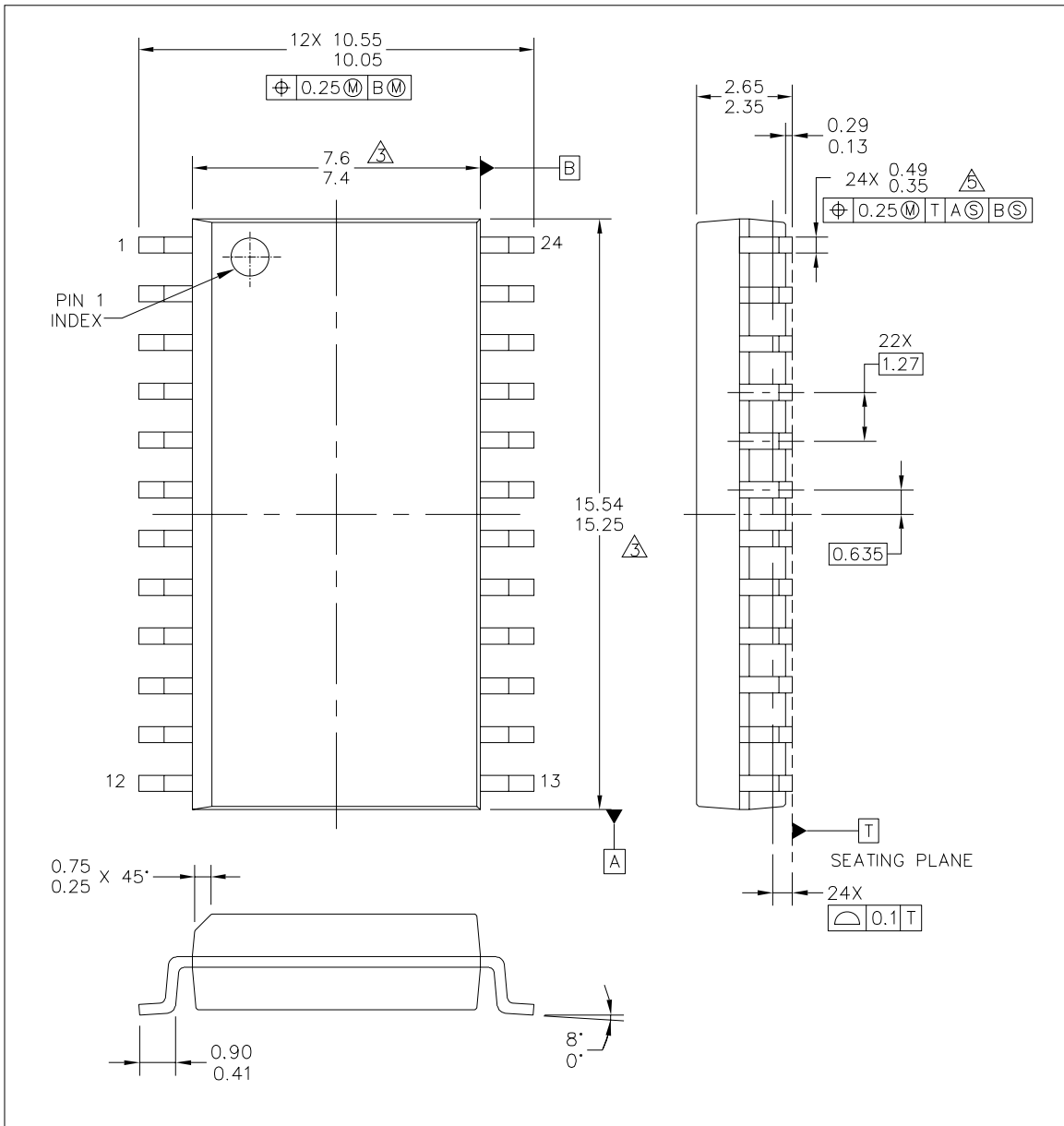

|                                                                   |                           |                            |  |
|-------------------------------------------------------------------|---------------------------|----------------------------|--|
| © FREESCALE SEMICONDUCTOR, INC.<br>ALL RIGHTS RESERVED.           | <b>MECHANICAL OUTLINE</b> | PRINT VERSION NOT TO SCALE |  |
| TITLE:<br>24LD SOIC W/B, 1.27 PITCH<br>7.5 X 15.4<br>CASE-OUTLINE | DOCUMENT NO: 98ASB42344B  | REV: G                     |  |
|                                                                   | CASE NUMBER: 751E-05      | 05 DEC 2007                |  |
|                                                                   | STANDARD: JEDEC MS-013 AD |                            |  |

**CASE 751E-05  
ISSUE G  
24-LEAD SOIC**

## PACKAGE DIMENSIONS

NOTES:

1. DIMENSIONING AND TOLERANCING PER ASME Y14.5M-1994.
2. DIMENSIONS ARE IN MILLIMETERS.
3. THIS DIMENSION DO NOT INCLUDE MOLD PROTRUSION.
4. MAXIMUM MOLD PROTRUSION 0.15(0.006) PER SIDE.
5. THIS DIMENSION DOES NOT INCLUDE DAM BAR PROTRUSION. ALLOWABLE DAM BAR PROTRUSION SHALL BE 0.13(0.005) TOTAL IN EXCESS OF THIS DIMENSION AT MAXIMUM MATERIAL CONDITION.

|                                                                |                           |                            |  |
|----------------------------------------------------------------|---------------------------|----------------------------|--|
| © FREESCALE SEMICONDUCTOR, INC.<br>ALL RIGHTS RESERVED.        | <b>MECHANICAL OUTLINE</b> | PRINT VERSION NOT TO SCALE |  |
| TITLE: 24LD SOIC W/B, 1.27 PITCH<br>7.5 X 15.4<br>CASE-OUTLINE | DOCUMENT NO: 98ASB42344B  | REV: G                     |  |
|                                                                | CASE NUMBER: 751E-05      | 05 DEC 2007                |  |
|                                                                | STANDARD: JEDEC MS-013 AD |                            |  |

PAGE 2 OF 2

**CASE 751E-05**  
**ISSUE G**  
**24-LEAD SOIC**

## **How to Reach Us:**

### **Home Page:**

[www.freescale.com](http://www.freescale.com)

### **Web Support:**

<http://www.freescale.com/support>

### **USA/Europe or Locations Not Listed:**

Freescale Semiconductor, Inc.  
Technical Information Center, EL516  
2100 East Elliot Road  
Tempe, Arizona 85284  
1-800-521-6274 or +1-480-768-2130  
[www.freescale.com/support](http://www.freescale.com/support)

### **Europe, Middle East, and Africa:**

Freescale Halbleiter Deutschland GmbH  
Technical Information Center  
Schatzbogen 7  
81829 Muenchen, Germany  
+44 1296 380 456 (English)  
+46 8 52200080 (English)  
+49 89 92103 559 (German)  
+33 1 69 35 48 48 (French)  
[www.freescale.com/support](http://www.freescale.com/support)

### **Japan:**

Freescale Semiconductor Japan Ltd.  
Headquarters  
ARCO Tower 15F  
1-8-1, Shimo-Meguro, Meguro-ku,  
Tokyo 153-0064  
Japan  
0120 191014 or +81 3 5437 9125  
[support.japan@freescale.com](mailto:support.japan@freescale.com)

### **Asia/Pacific:**

Freescale Semiconductor China Ltd.  
Exchange Building 23F  
No. 118 Jianguo Road  
Chaoyang District  
Beijing 100022  
China  
+86 010 5879 8000  
[support.asia@freescale.com](mailto:support.asia@freescale.com)

### **For Literature Requests Only:**

Freescale Semiconductor Literature Distribution Center  
P.O. Box 5405  
Denver, Colorado 80217  
1-800-441-2447 or +1-303-675-2140

Information in this document is provided solely to enable system and software implementers to use Freescale Semiconductor products. There are no express or implied copyright licenses granted hereunder to design or fabricate any integrated circuits or integrated circuits based on the information in this document.

Freescale Semiconductor reserves the right to make changes without further notice to any products herein. Freescale Semiconductor makes no warranty, representation or guarantee regarding the suitability of its products for any particular purpose, nor does Freescale Semiconductor assume any liability arising out of the application or use of any product or circuit, and specifically disclaims any and all liability, including without limitation consequential or incidental damages. "Typical" parameters that may be provided in Freescale Semiconductor data sheets and/or specifications can and do vary in different applications and actual performance may vary over time. All operating parameters, including "Typicals", must be validated for each customer application by customer's technical experts. Freescale Semiconductor does not convey any license under its patent rights nor the rights of others. Freescale Semiconductor products are not designed, intended, or authorized for use as components in systems intended for surgical implant into the body, or other applications intended to support or sustain life, or for any other application in which the failure of the Freescale Semiconductor product could create a situation where personal injury or death may occur. Should Buyer purchase or use Freescale Semiconductor products for any such unintended or unauthorized application, Buyer shall indemnify and hold Freescale Semiconductor and its officers, employees, subsidiaries, affiliates, and distributors harmless against all claims, costs, damages, and expenses, and reasonable attorney fees arising out of, directly or indirectly, any claim of personal injury or death associated with such unintended or unauthorized use, even if such claim alleges that Freescale Semiconductor was negligent regarding the design or manufacture of the part.

Freescale™ and the Freescale logo are trademarks of Freescale Semiconductor, Inc. All other product or service names are the property of their respective owners.

© Freescale Semiconductor, Inc. 2008. All rights reserved.