

Low-Power CMOS Ionization Smoke Detector IC with Interconnect and Temporal Horn Driver

The MC145018, when used with an ionization chamber and a small number of external components, will detect smoke. When smoke is sensed, an alarm is sounded via an external piezoelectric transducer and internal drivers. This circuit is designed to operate in smoke detector systems that comply with UL217 and UL268 specifications.

Features

- Ionization Type with On-Chip FET Input Comparator
- Piezoelectric Horn Driver
- Guard Outputs on Both Sides of Detect Input
- Input-Protection Diodes on the Detect Input
- Low-Battery Trip Point, Internally Set, can be Altered Via External Resistor
- Detect Threshold, Internally Set, can be Altered Via External Resistor
- Pulse Testing for Low Battery Uses LED for Battery Loading
- Comparator Output for Detect
- Internal Reverse Battery Protection
- Strobe Output for External Trim Resistors
- I/O Pin Allows Up to 40 Units to be Connected for Common Signaling
- Supports NFPA 72, ANSi 53.41, and ISO 8201 Audible Emergency Evacuation Signals
- Power-On Reset Places IC in Standby Mode
- Pb-Free Packaging Designated by Suffix Code ED

ORDERING INFORMATION		
Device	Case No.	Package
MC145018P	648-08	Plastic Dip
MC145018ED		

MC145018

**IONIZATION SMOKE DETECTOR
 IC WITH INTERCONNECT AND
 TEMPORAL HORN DRIVER**

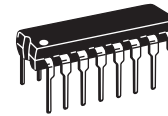

**P SUFFIX
 ED SUFFIX (PB-FREE)
 PLASTIC DIP
 CASE 648-08**

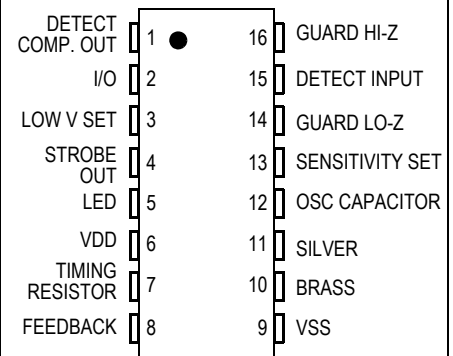

Figure 1. Pin Assignment

Archive Information

Archive Information

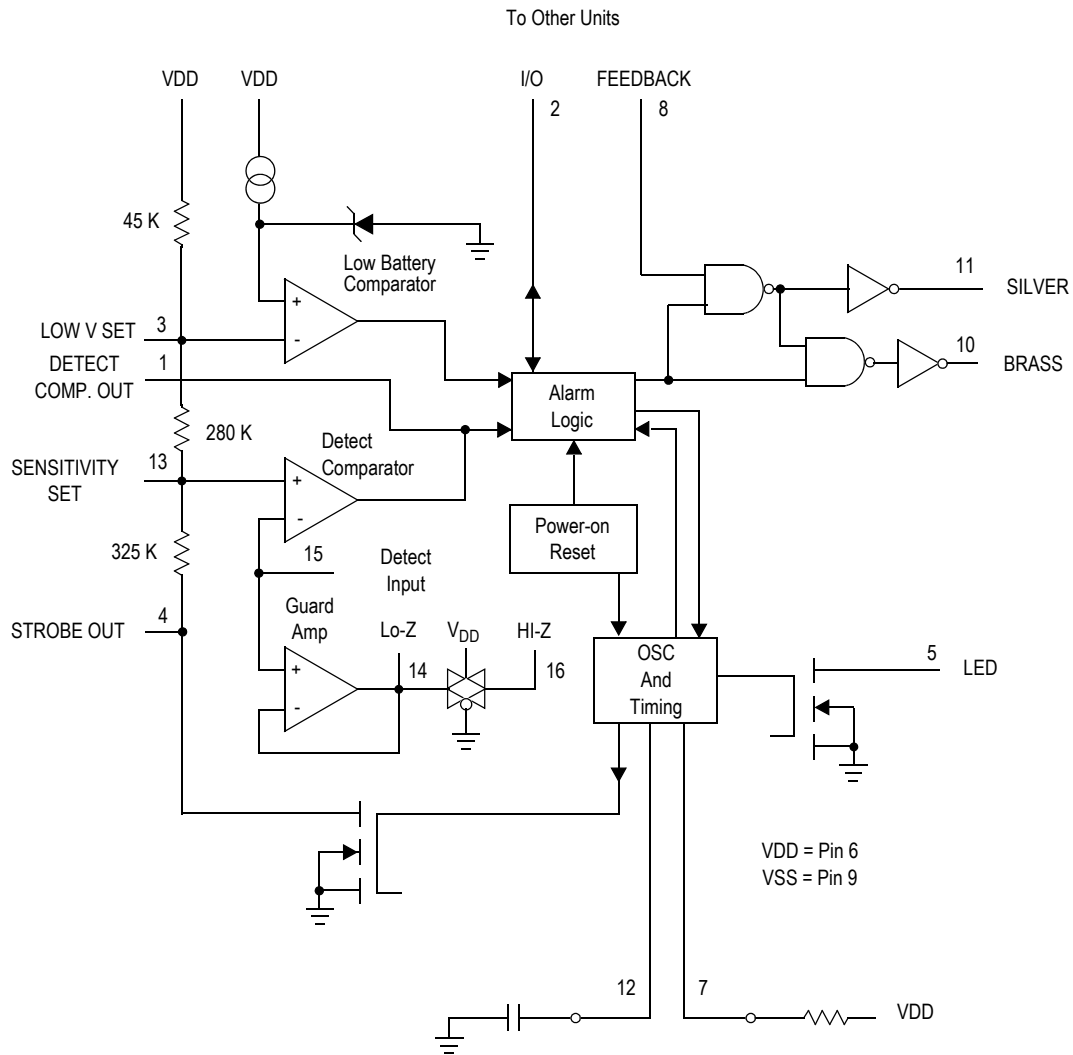

Figure 2. Block Diagram

Table 1. Maximum Ratings⁽¹⁾
(Voltages referenced to V_{SS})

Rating	Symbol	Value	Unit
DC Supply Voltage	V _{DD}	-0.5 to + 15	V
Input Voltage, All Inputs Except Pin 8	V _{IN}	-0.25 to V _{DD} + 0.25	V
DC Current Drain per Input Pin, Except Pin 15 = 1 mA	I	10	mA
DC Current Drain per Output Pin	I	30	mA
Operating Temperature Range	T _A	-10 to + 60	°C
Storage Temperature Range	T _{STG}	-55 to + 125	°C
Reverse Battery Time	t _{RB}	5.0	s

1. Maximum Ratings are those values beyond which damage to the device may occur.

This device contains circuitry to protect the inputs against damage due to high static voltages or electric fields; however, it is advised that normal precautions be taken to avoid application of any voltage higher than maximum rated voltages to this high impedance circuit. For proper operation it is recommended that V_{in} and V_{out} be constrained to the range V_{SS} ≤ (V_{in} or V_{out}) ≤ V_{DD}.

Table 2. Recommended Operating Conditions

 (Voltages referenced to V_{SS})

Parameter	Symbol	Value	Unit
Supply Voltage	V_{DD}	9.0	V
Timing Capacitor	—	0.1	μF
Timing Resistor	—	8.2	$\text{M}\Omega$
Battery Load (Resistor or LED)	—	10	mA

Table 3. Electrical Characteristics

 (Voltages referenced to V_{SS} , $T_A = 25^\circ\text{C}$)

Characteristic	Symbol	V_{DD} V_{DC}	Min	Typ ⁽¹⁾	Max	Unit
Operating Voltage	V_{DD}	—	6.0	—	12	V
Output Voltage	V_{OH}	7.2	6.3	—	—	V
Piezoelectric Horn Drivers ($I_{OH} = -16 \text{ mA}$)		9.0	8.5	8.8	—	
Comparators ($I_{OH} = -30 \mu\text{A}$)		7.2	—	—	0.9	V
Piezoelectric Horn Drivers ($I_{OL} = +16 \text{ mA}$)	V_{OL}	9.0	—	0.1	0.5	
Comparators ($I_{OL} = +30 \mu\text{A}$)						
Output Voltage - LED Driver, $I_{OL} = 10 \text{ mA}$	V_{OL}	7.2	—	—	3.0	V
Output Impedance, Active Guard						
Pin 14	LO-Z	9.0	—	—	10	$\text{k}\Omega$
Pin 16	HI-Z	9.0	—	—	1000	
Operating Current ($R_{bias} = 8.2 \text{ M}\Omega$)	I_{DD}	9.0 12.0	— —	5.0 —	9.0 12.0	μA
Input Current - Detect (40% R.H.)	I_{IN}	9.0	—	—	± 1.0	μA
Input Current, Pin 8	I_{IN}	9.0	—	—	± 0.1	μA
Input Current @ 50°C , Pin 15	I_{IN}	—	—	—	± 6.0	μA
Internal Set Voltage						
Low Battery	V_{LOW}	9.0	7.2	—	7.8	V
Sensitivity	V_{SET}	—	47	50	53	$\%V_{DD}$
Hysteresis	V_{HYS}	9.0	75	100	150	mV
Offset Voltage (measured at $V_{IN} = V_{DD}/2$)	V_{OS}					
Active Guard		9.0	—	—	± 100	mV
Detect Comparator		9.0	—	—	± 50	
Input Voltage Range, Pin 8	V_{IN}	—	$V_{SS} - 10$	—	$V_{DD} + 10$	V
Input Capacitance	C_{IN}	—	—	5.0	—	pF
Common Mode Voltage Range, Pin 15	V_{CM}	—	0.6	—	$V_{DD} - 2$	V
I/O Current, Pin 2						
Input, $V_{IH} = V_{DD} - 2$	I_{IH}	—	25	—	100	μA
Output, $V_{OH} = V_{DD} - 2$	I_{OH}	—	-4.0	—	-16	mA

1. Data labelled "Typ" is not to be used for design purposes but is intended as an indication of the IC's potential performance.

Table 4. Timing Parameters

(C = 0.1 μ F, R_{bias} = 8.2 M Ω , V_{DD} = 9.0 V, T_A = 25°C, See Figure 7)

Characteristics		Symbol	Min	Max	Units
Oscillator Period	No Smoke	t _{Cl}	1.46	1.85	s
	Smoke		37.5	45.8	ms
Oscillator Rise Time		t _R	10.1	12.3	ms
Horn Output (During Smoke)	On Time	PW _{ON}	450	550	ms
	Off Time	PW _{OFF}	450	550	ms
LED Output	Between Pulses	t _{LED}	35.0	44.5	s
	On Time	PW _{ON}	10.1	12.3	ms
Horn Output (During Low Battery)	On Time	t _{ON}	10.1	12.3	ms
	Between Pulses	t _{OFF}	35.0	44.5	s

Archive Information

Archive Information

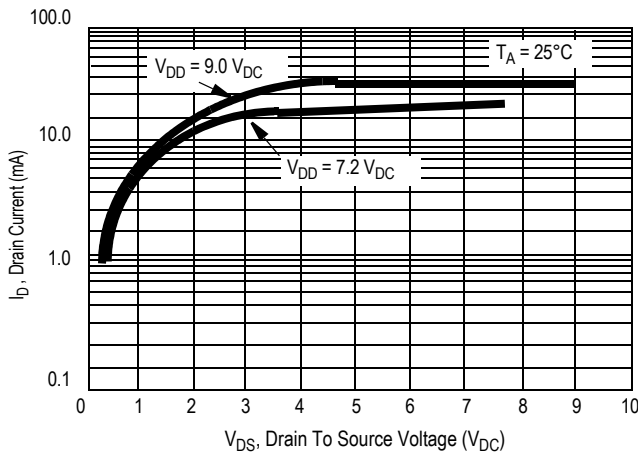

Figure 3. Typical LED Output I-V Characteristic

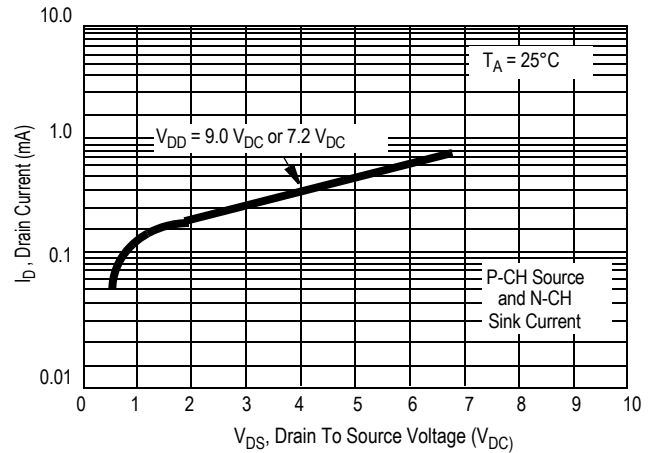

Figure 4. Typical Comparator Output I-V Characteristic

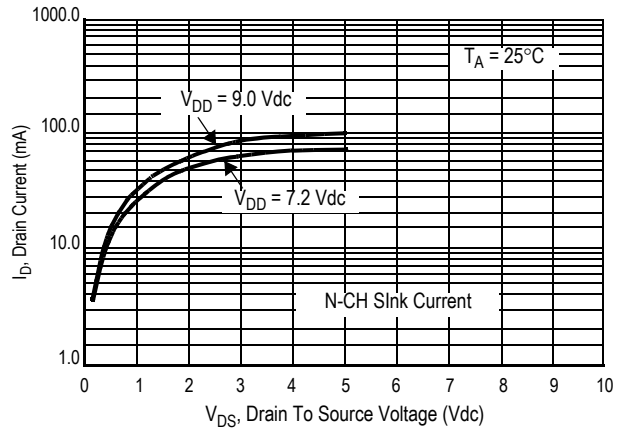
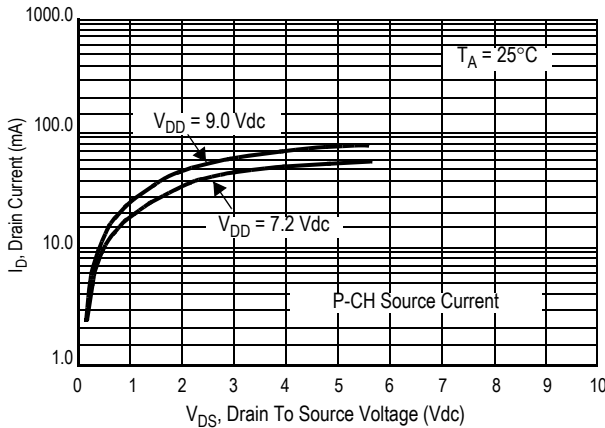

Figure 5. Typical P Horn Driver Output I-V Characteristic

DEVICE OPERATION

Timing

The internal oscillator of the MC145018 operates with a period of 1.65 seconds during no-smoke conditions. Each 1.65 seconds, internal power is applied to the entire IC and a check is made for smoke, except during LED pulse, Low Battery Alarm Chirp, or Horn Modulation (in smoke). Every 24 clock cycles a check is made for low battery by comparing

V_{DD} to an internal zener voltage. Since very small currents are used in the oscillator, the oscillator capacitor should be of a low leakage type.

Detect Circuitry

If smoke is detected, the oscillator period becomes 41.67 ms and the piezoelectric horn oscillator circuit is

enabled. The horn output is modulated 500 ms on, 500 ms off. During the off time, smoke is again checked and will inhibit further horn output if no smoke is sensed. During local smoke conditions the low battery alarm is inhibited, but the LED pulses at a 1.0 Hz rate. In remote smoke, the LED is inhibited as well.

An active guard is provided on both pins adjacent to the detect input. The voltage at these pins will be within 100 mV of the input signal. This will keep surface leakage currents to a minimum and provide a method of measuring the input voltage without loading the ionization chamber. The active guard op amp is not power strobed and thus gives constant protection from surface leakage currents. Pin 15 (the Detect input) has internal diode protection against static damage.

Interconnect

The I/O (Pin 2), in combination with V_{SS}, is used to interconnect up to 40 remote units for common signaling. A Local Smoke condition activates a current limited output driver, thereby signaling Remote Smoke to interconnected units. A small current sink improves noise immunity during non-smoke conditions. Remote units at lower voltages do not draw excessive current from a sending unit at a higher voltage. The I/O is disabled for three oscillator cycles after power up, to eliminate false alarming of remote units when the battery is changed.

Sensitivity/Low Battery Thresholds

Both the sensitivity threshold and the low battery voltage levels are set internally by a common voltage divider (see

Figure 2) connected between VDD and VSS. These voltages can be altered by external resistors connected from pins 3 or 13 to either VDD or VSS. There will be a slight interaction here due to the common voltage divider network. The sensitivity threshold can also be be set by adjusting the smoke chamber ionization source.

Test Mode

Since the internal op amps and comparators are power strobed, adjustments for sensitivity or low battery level could be difficult and/or time-consuming. By forcing Pin 12 to V_{SS}, the power strobing is bypassed and the output, Pin 1, constantly shows smoke/no smoke. Pin 1 = VDD for smoke. In this mode and during the 10 ms power strobe, chip current rises to approximately 50 μA.

LED Pulse

The 9-volt battery level is checked every 40 seconds during the LED pulse. The battery is loaded via a 10 mA pulse for 11.6 ms. If the LED is not used, it should be replaced with an equivalent resistor such that the battery loading remains at 10 mA.

Hysteresis

When smoke is detected, the resistor/divider network that sets sensitivity is altered to increase sensitivity. This yields approximately 100 mV of hysteresis and reduces false triggering.

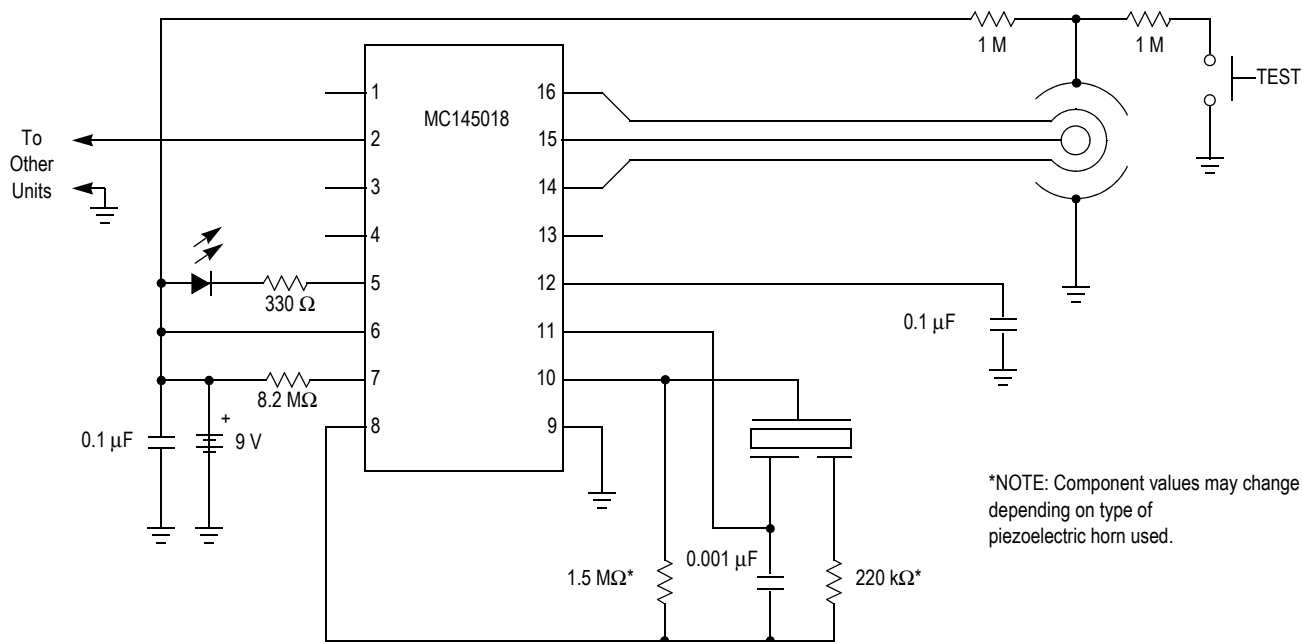

Figure 6. Typical Application as Ionization Smoke Detector

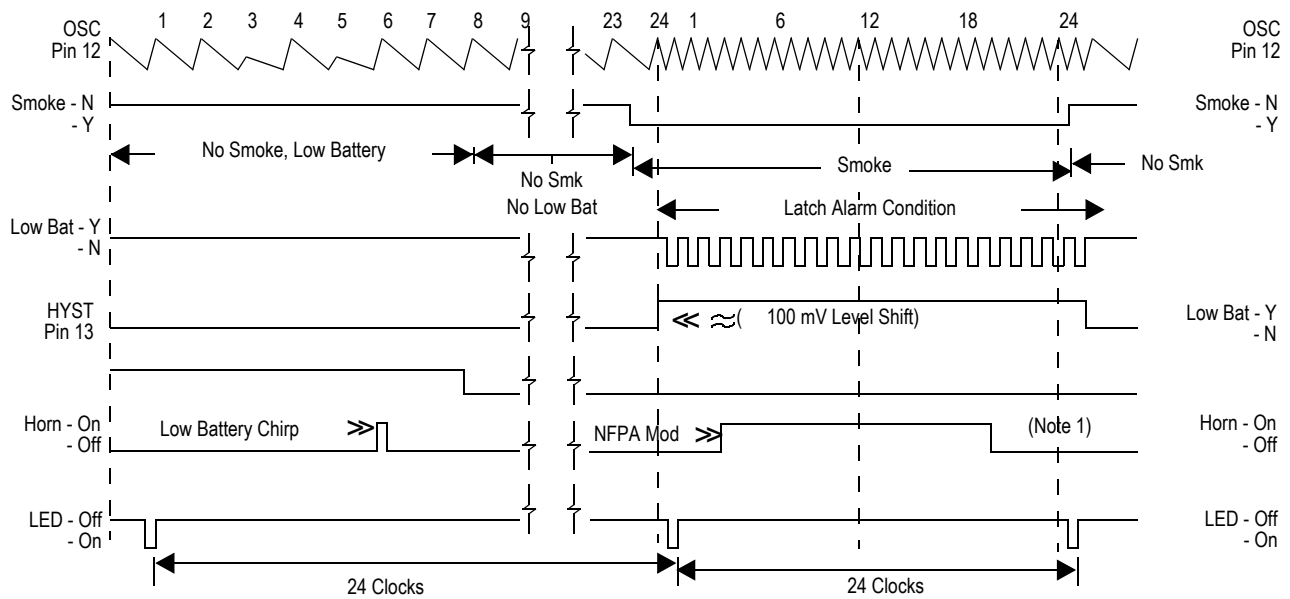

Figure 7. MC145017 Timing Diagram

NOTE:

1. Horn modulation is self-completing. When going from smoke to no smoke, the alarm condition will terminate only when horn is off.
Comparators are strobed once per cycle (1.65 sec for no smoke, 40 msec for smoke).
For timing under remote conditions, refer to MC14468 data sheet.

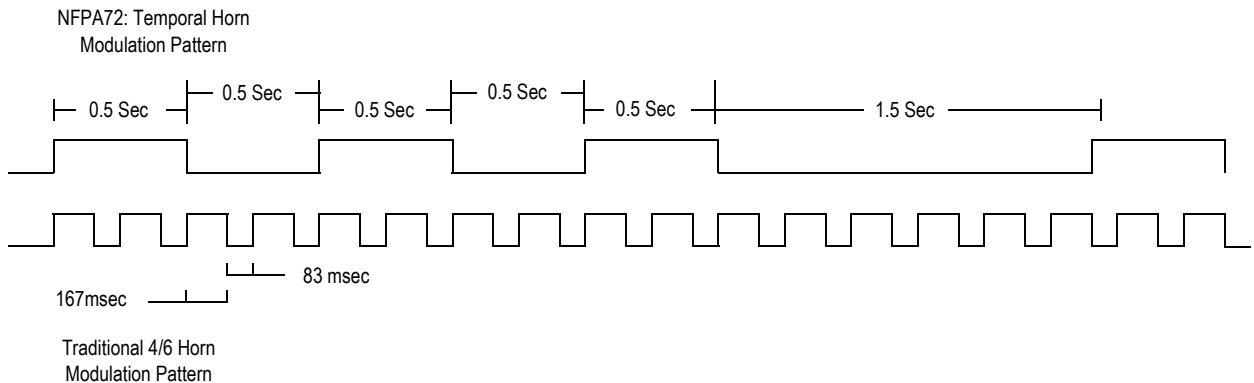
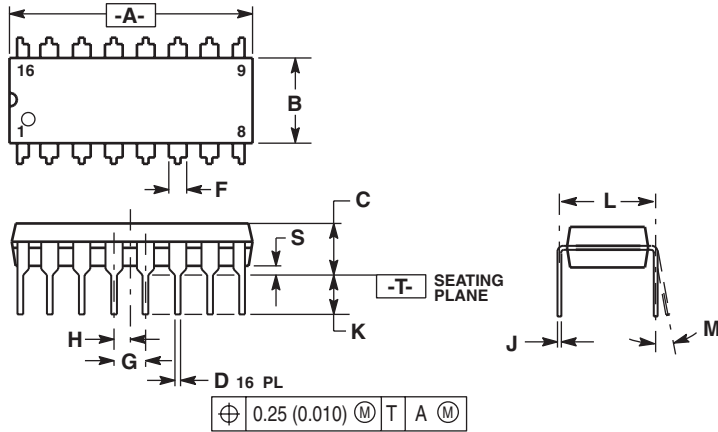

Figure 8. Horn Modulation

PACKAGE DIMENSIONS



- NOTES:
1. DIMENSIONING AND TOLERANCING PER ANSI Y14.5M, 1982.
 2. CONTROLLING DIMENSION: INCH.
 3. DIMENSION L TO CENTER OF LEADS WHEN FORMED PARALLEL.
 4. DIMENSION B DOES NOT INCLUDE MOLD FLASH.
 5. ROUNDED CORNERS OPTIONAL.

DIM	INCHES		MILLIMETERS	
	MIN	MAX	MIN	MAX
A	0.740	0.770	18.80	19.55
B	0.250	0.270	6.35	6.85
C	0.145	0.175	3.69	4.44
D	0.015	0.021	0.39	0.53
F	0.040	0.70	1.02	1.77
G	0.100 BSC		2.54 BSC	
H	0.050 BSC		1.27 BSC	
J	0.008	0.015	0.21	0.38
K	0.110	0.130	2.80	3.30
L	0.295	0.305	7.50	7.74
M	0	10	0	10
S	0.020	0.040	0.51	1.01

- STYLE 1:
- PIN 1. CATHODE
 - 2. CATHODE
 - 3. CATHODE
 - 4. CATHODE
 - 5. CATHODE
 - 6. CATHODE
 - 7. CATHODE
 - 8. CATHODE
 - 9. ANODE
 - 10. ANODE
 - 11. ANODE
 - 12. ANODE
 - 13. ANODE
 - 14. ANODE
 - 15. ANODE
 - 16. ANODE
- STYLE 2:
- PIN 1. COMMON DRAIN
 - 2. COMMON DRAIN
 - 3. COMMON DRAIN
 - 4. COMMON DRAIN
 - 5. COMMON DRAIN
 - 6. COMMON DRAIN
 - 7. COMMON DRAIN
 - 8. COMMON DRAIN
 - 9. GATE
 - 10. SOURCE
 - 11. GATE
 - 12. SOURCE
 - 13. GATE
 - 14. SOURCE
 - 15. GATE
 - 16. SOURCE

**CASE 648-08
ISSUE R
16-LEAD PLASTIC DIP**

Archive Information

Archive Information

How to Reach Us:

Home Page:
www.freescale.com

E-mail:
support@freescale.com

USA/Europe or Locations Not Listed:
Freescale Semiconductor
Technical Information Center, CH370
1300 N. Alma School Road
Chandler, Arizona 85224
+1-800-521-6274 or +1-480-768-2130
support@freescale.com

Europe, Middle East, and Africa:
Freescale Halbleiter Deutschland GmbH
Technical Information Center
Schatzbogen 7
81829 Muenchen, Germany
+44 1296 380 456 (English)
+46 8 52200080 (English)
+49 89 92103 559 (German)
+33 1 69 35 48 48 (French)
support@freescale.com

Japan:
Freescale Semiconductor Japan Ltd.
Headquarters
ARCO Tower 15F
1-8-1, Shimo-Meguro, Meguro-ku,
Tokyo 153-0064
Japan
0120 191014 or +81 3 5437 9125
support.japan@freescale.com

Asia/Pacific:
Freescale Semiconductor Hong Kong Ltd.
Technical Information Center
2 Dai King Street
Tai Po Industrial Estate
Tai Po, N.T., Hong Kong
+800 2666 8080
support.asia@freescale.com

For Literature Requests Only:
Freescale Semiconductor Literature Distribution Center
P.O. Box 5405
Denver, Colorado 80217
1-800-441-2447 or 303-675-2140
Fax: 303-675-2150
LDCForFreescaleSemiconductor@hibbertgroup.com

RoHS-compliant and/or Pb-free versions of Freescale products have the functionality and electrical characteristics of their non-RoHS-compliant and/or non-Pb-free counterparts. For further information, see <http://www.freescale.com> or contact your Freescale sales representative.

For information on Freescale's Environmental Products program, go to <http://www.freescale.com/epp>.

Information in this document is provided solely to enable system and software implementers to use Freescale Semiconductor products. There are no express or implied copyright licenses granted hereunder to design or fabricate any integrated circuits or integrated circuits based on the information in this document.

Freescale Semiconductor reserves the right to make changes without further notice to any products herein. Freescale Semiconductor makes no warranty, representation or guarantee regarding the suitability of its products for any particular purpose, nor does Freescale Semiconductor assume any liability arising out of the application or use of any product or circuit, and specifically disclaims any and all liability, including without limitation consequential or incidental damages. "Typical" parameters that may be provided in Freescale Semiconductor data sheets and/or specifications can and do vary in different applications and actual performance may vary over time. All operating parameters, including "Typicals", must be validated for each customer application by customer's technical experts. Freescale Semiconductor does not convey any license under its patent rights nor the rights of others. Freescale Semiconductor products are not designed, intended, or authorized for use as components in systems intended for surgical implant into the body, or other applications intended to support or sustain life, or for any other application in which the failure of the Freescale Semiconductor product could create a situation where personal injury or death may occur. Should Buyer purchase or use Freescale Semiconductor products for any such unintended or unauthorized application, Buyer shall indemnify and hold Freescale Semiconductor and its officers, employees, subsidiaries, affiliates, and distributors harmless against all claims, costs, damages, and expenses, and reasonable attorney fees arising out of, directly or indirectly, any claim of personal injury or death associated with such unintended or unauthorized use, even if such claim alleges that Freescale Semiconductor was negligent regarding the design or manufacture of the part.

Freescale™ and the Freescale logo are trademarks of Freescale Semiconductor, Inc. All other product or service names are the property of their respective owners.

© Freescale Semiconductor, Inc. 2006. All rights reserved.

