

# Low-Power CMOS Ionization Smoke Detector IC

The MC14467-1, when used with an ionization chamber and a small number of external components, will detect smoke. When smoke is sensed, an alarm is sounded via an external piezoelectric transducer and internal drivers. This circuit is designed to operate in smoke detector systems that comply with UL217 and UL268 specifications.

### Features

- Ionization Type with On-Chip FET Input Comparator
- Piezoelectric Horn Driver
- Guard Outputs on Both Sides of Detect Input
- Input-Production Diodes on the Detect Input
- Low-Battery Trip Point, Internally Set, can be Altered Via External Resistor
- Detect Threshold, Internally Set, can be Altered Via External Resistor
- Pulse Testing for Low Battery Uses LED for Battery Loading
- Comparator Outputs for Detect and Low Battery
- Internal Reverse Battery Protection

ORDERING INFORMATION		
Device	Case No.	Package
MC14467P1	648-08	Plastic Dip

**MC14467-1**

**LOW-POWER CMOS  
 IONIZATION  
 SMOKE DETECTOR IC**

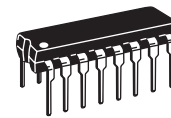

**P SUFFIX  
 16-LEAD PLASTIC DIP  
 CASE 648-08**

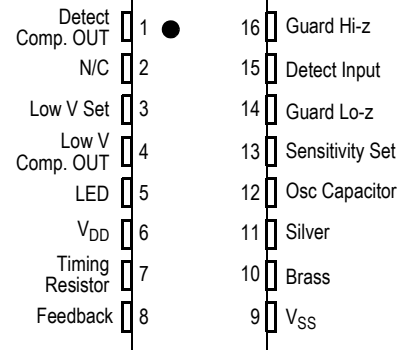

**Figure 1. Pin Connections**

Archive Information

Archive Information

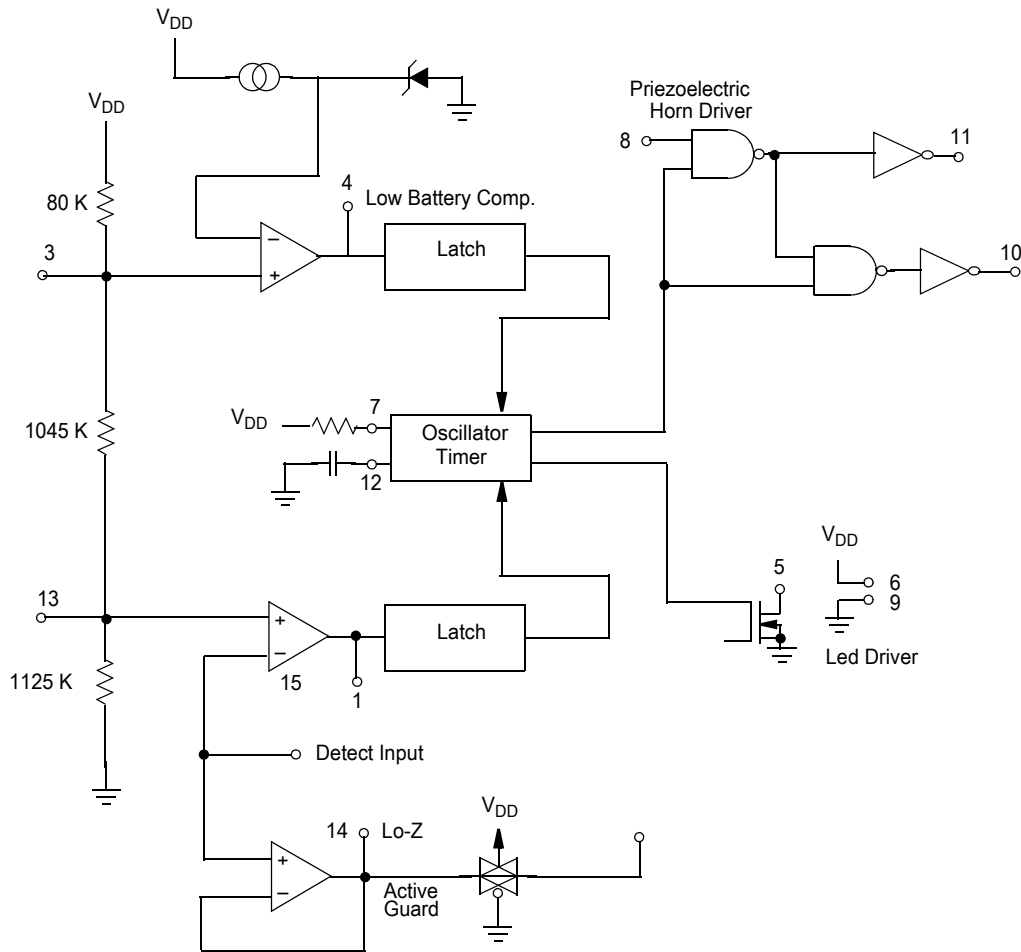

**Figure 2. Block Diagram**

**Table 1. Maximum Ratings<sup>(1)</sup>**  
(Voltages referenced to  $V_{SS}$ )

Rating	Symbol	Value	Unit
DC Supply Voltage	$V_{DD}$	-0.5 to + 15	V
Input Voltage, All Inputs Except Pin 8	$V_{in}$	-0.25 to $V_{DD} + 0.25$	V
DC Current Drain per Input Pin, Except Pin 15 = 1 mA	I	10	mA
DC Current Drain per Output Pin	I	30	mA
Operating Temperature Range	$T_A$	-10 to +60	°C
Storage Temperature Range	$T_{stg}$	-55 to + 125	°C
Reverse Battery Time	$t_{RB}$	5.0	s

1. Maximum Ratings are those values beyond which damage to the device may occur. This device contains circuitry to protect the inputs against damage due to high static voltages or electric fields; however, it is advised that normal precautions be taken to avoid application of any voltage higher than maximum rated voltages to this high impedance circuit. For proper operation it is recommended that except for pin 8,  $V_{in}$  and  $V_{out}$  be constrained to the range  $V_{SS} \leq (V_{in} \text{ or } V_{out}) \leq V_{DD}$ . For pin 8, refer to the Electrical Characteristics.

**Table 2. Recommended Operating Conditions**

(Voltages referenced to  $V_{SS}$ )

Parameter	Symbol	Value	Unit
Supply Voltage	$V_{DD}$	9.0	V
Timing Capacitor	—	0.1	$\mu\text{F}$
Timing Resistor	—	8.2	$\text{M}\Omega$
Battery Load (Resistor or LED)	—	10	mA

**Table 3. Electrical Characteristics**

(Voltages referenced to  $V_{SS}$ ,  $T_A = 25^\circ\text{C}$ )

Characteristic	Symbol	$V_{DD}$ $V_{DC}$	Min	Typ <sup>(1)</sup>	Max	Unit
Operating Voltage	$V_{DD}$	—	6.0	—	12	V
Output Voltage	$V_{OH}$					V
Piezoelectric Horn Drivers ( $I_{OH} = -16 \text{ mA}$ )		7.2	6.3	—	—	
Comparators ( $I_{OH} = -30 \mu\text{A}$ )		9.0	8.5	8.8	—	
Piezoelectric Horn Drivers ( $I_{OL} = +16 \text{ mA}$ )	$V_{OL}$	7.2	—	—	0.9	V
Comparators ( $I_{OL} = +30 \mu\text{A}$ )		9.0	—	0.1	0.5	
Output Voltage - LED Driver, $I_{OL} = 10 \text{ mA}$	$V_{OL}$	7.2	—	—	3.0	V
Output Impedance, Active Guard						$\text{k}\Omega$
Pin 14	Lo-Z	9.0	—	—	10	
Pin 16	Hi-Z	9.0	—	—	1000	
Operating Current ( $R_{bias} = 8.2 \text{ M}\Omega$ )	$I_{DD}$	9.0 12.0	— —	5.0 —	9.0 12.0	$\mu\text{A}$
Input Current - Detect (40% R.H.)	$I_{in}$	9.0	—	—	$\pm 1.0$	$\mu\text{A}$
Internal Set Voltage						
Low Battery	$V_{low}$	9.0	7.2	—	7.8	V
Sensitivity	$V_{set}$	—	47	50	53	$\%V_{DD}$
Hysteresis	$V_{hys}$	9.0	75	100	150	mV
Offset Voltage (measured at $V_{in} = V_{DD}/2$ )	$V_{OS}$					mV
Active Guard		9.0	—	—	$\pm 100$	
Detect Comparator		9.0	—	—	$\pm 50$	
Input Voltage Range, Pin 8	$V_{in}$	—	$V_{SS} - 10$	—	$V_{DD} + 10$	V
Input Capacitance	$C_{in}$	—	—	5.0	—	pF
Common Mode Voltage Range, Pin 15	$V_{cm}$	—	0.6	—	$V_{DD} - 2$	V

1. Data labelled "Typ" is not to be used for design purposes but is intended as an indication of the IC's potential performance.

Archive Information

Archive Information

**Table 4. Timing Parameters**

(C = 0.1  $\mu$ F, R<sub>bias</sub> = 8.2 M $\Omega$ , V<sub>DD</sub> = 9.0 V, T<sub>A</sub> = 25°C, See Figure 7)

Characteristics		Symbol	Min	Typ <sup>(1)</sup>	Max	Units
Oscillator Period	No Smoke	t <sub>Cl</sub>	1.34	1.67	2.0	s
	Smoke		32	40	48	ms
Oscillator Rise Time		t <sub>r</sub>	8.0	10	12	ms
Horn Output (During Smoke)	On Time	PW <sub>on</sub>	120	160	208	ms
	Off Time	PW <sub>off</sub>	60	80	104	ms
LED Output	Between Pulses	t <sub>LED</sub>	32	40	48	s
	On Time		PW <sub>on</sub>	8.0	10	12
Horn Output (During Low Battery)	On Time	t <sub>on</sub>	8.0	10	12	ms
	Between Pulses		t <sub>off</sub>	32	40	48

1. Data labelled "Typ" is not to be used for design purposes but is intended as an indication of the IC's potential performance.

Archive Information

Archive Information

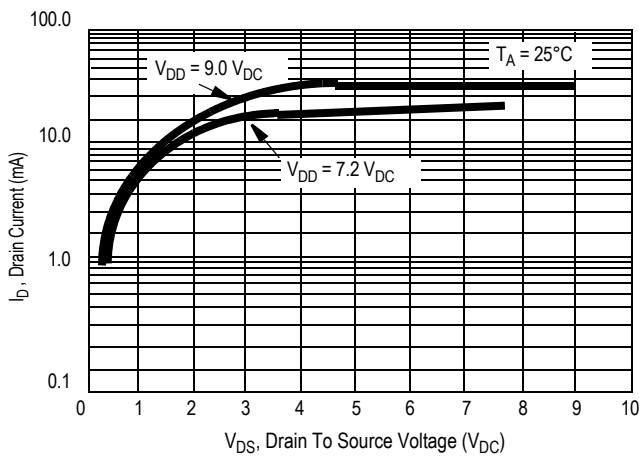

**Figure 3. Typical LED Output I-V Characteristic**

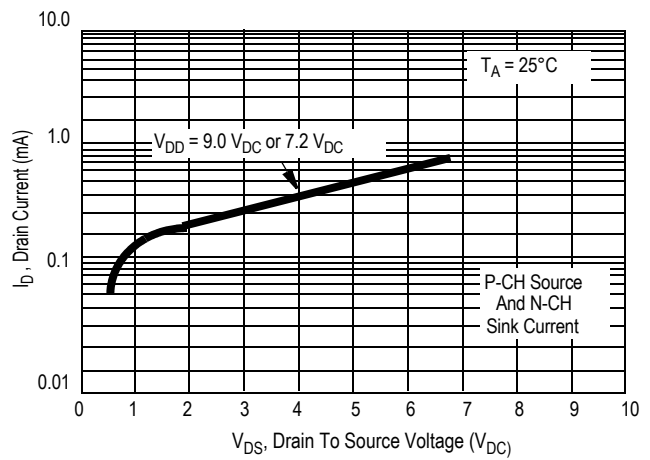

**Figure 4. Typical Comparator Output I-V Characteristic**

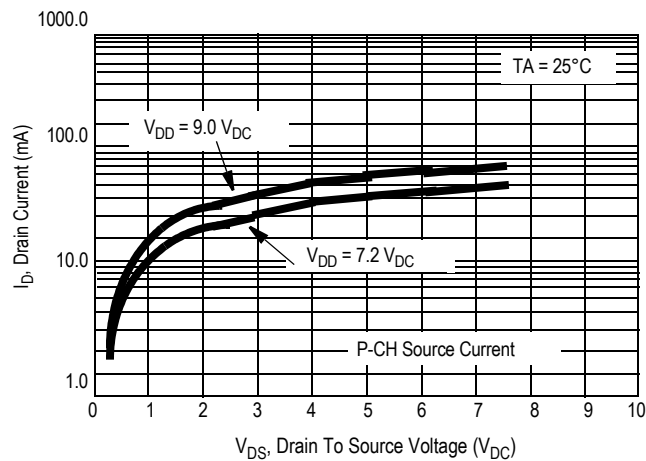

**Figure 5. Typical P Horn Driver Output I-V Characteristic**

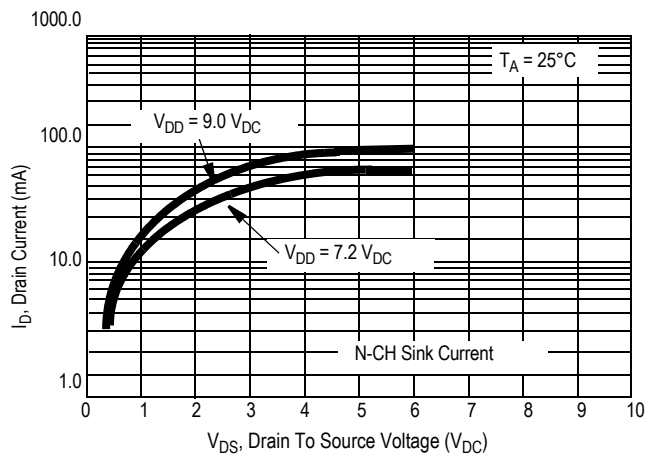

## DEVICE OPERATION

### Timing

The internal oscillator of the MC14467-1 operates with a period of 1.67 seconds during no-smoke conditions. Each 1.67 seconds, internal power is applied to the entire IC and a check is made for smoke, except during LED pulse, Low Battery Alarm Chirp, or Horn Modulation (in smoke). Every 24 clock cycles a check is made for low battery by comparing  $V_{DD}$  to an internal zener voltage. Since very small currents are used in the oscillator, the oscillator capacitor should be of a low leakage type.

### Detect Circuitry

If smoke is detected, the oscillator period becomes 40 ms and the piezoelectric horn oscillator circuit is enabled. The horn output is modulated 160 ms on, 80 ms off. During the off time, smoke is again checked and will inhibit further horn output if no smoke is sensed. During smoke conditions the low battery alarm is inhibited, but the LED pulses at a 1.0 Hz rate.

An active guard is provided on both pins adjacent to the detect input. The voltage at these pins will be within 100 mV of the input signal. This will keep surface leakage currents to a minimum and provide a method of measuring the input voltage without loading the ionization chamber. The active guard op amp is not power strobed and thus gives constant protection from surface leakage currents. Pin 15 (the Detect input) has internal diode protection against static damage.

### Sensitivity/Low Battery Thresholds

Both the sensitivity threshold and the low battery voltage levels are set internally by a common voltage divider (please

see Figure 2) connected between  $V_{DD}$  and  $V_{SS}$ . These voltages can be altered by external resistors connected from pins 3 or 13 to either  $V_{DD}$  or  $V_{SS}$ . There will be a slight interaction here due to the common voltage divider network. The sensitivity threshold can also be be set by adjusting the smoke chamber ionization source.

### Test Mode

Since the internal op amps and comparators are power strobed, adjustments for sensitivity or low battery level could be difficult and/or time-consuming. By forcing Pin 12 to  $V_{SS}$ , the power strobing is bypassed and the outputs, Pins 1 and 4, constantly show smoke/no smoke and good battery/low battery, respectively. Pin 1 =  $V_{DD}$  for smoke and Pin 4 =  $V_{DD}$  for low battery. In this mode and during the 10 ms power strobe, chip current rises to approximately 50  $\mu$ A.

### LED Pulse

The 9-volt battery level is checked every 40 seconds during the LED pulse. The battery is loaded via a 10 mA pulse for 10 ms. If the LED is not used, it should be replaced with an equivalent resistor such that the battery loading remains at 10 mA.

### Hysteresis

When smoke is detected, the resistor/divider network that sets sensitivity is altered to increase sensitivity. This yields approximately 100 mV of hysteresis and reduces false triggering.

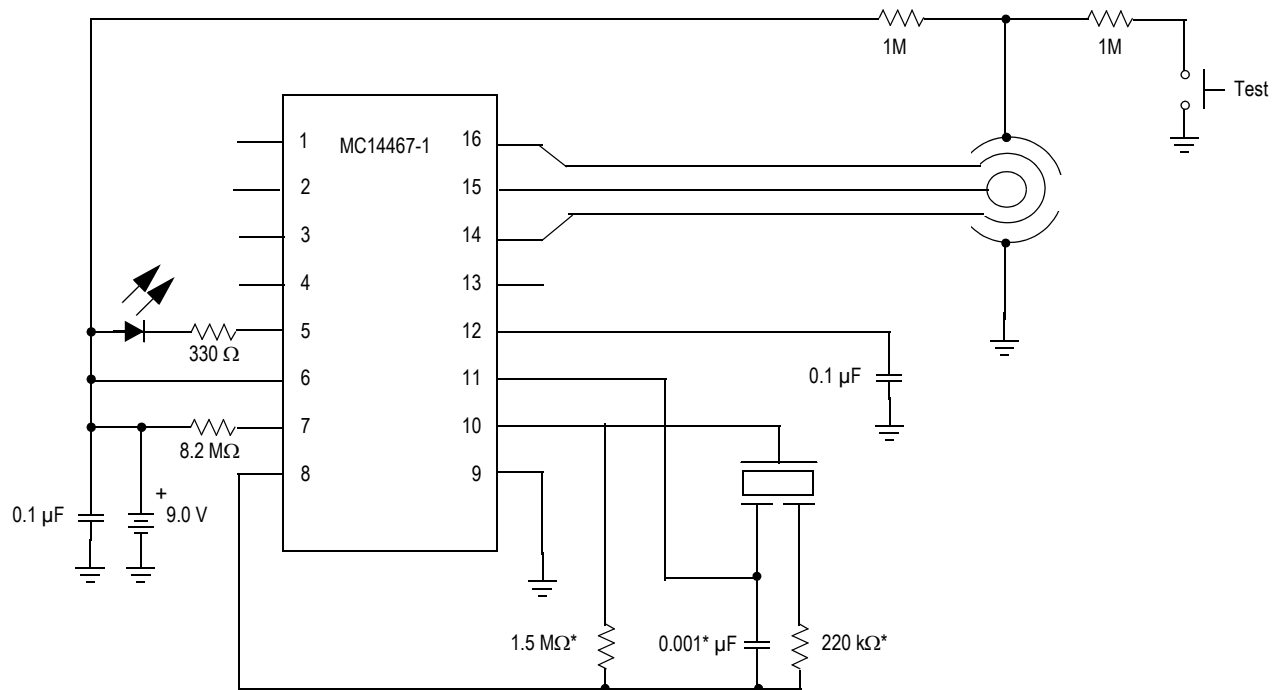

\*NOTE: Component values may change depending on type of piezoelectric horn used.

Figure 6. Typical Application as Ionization Smoke Detector

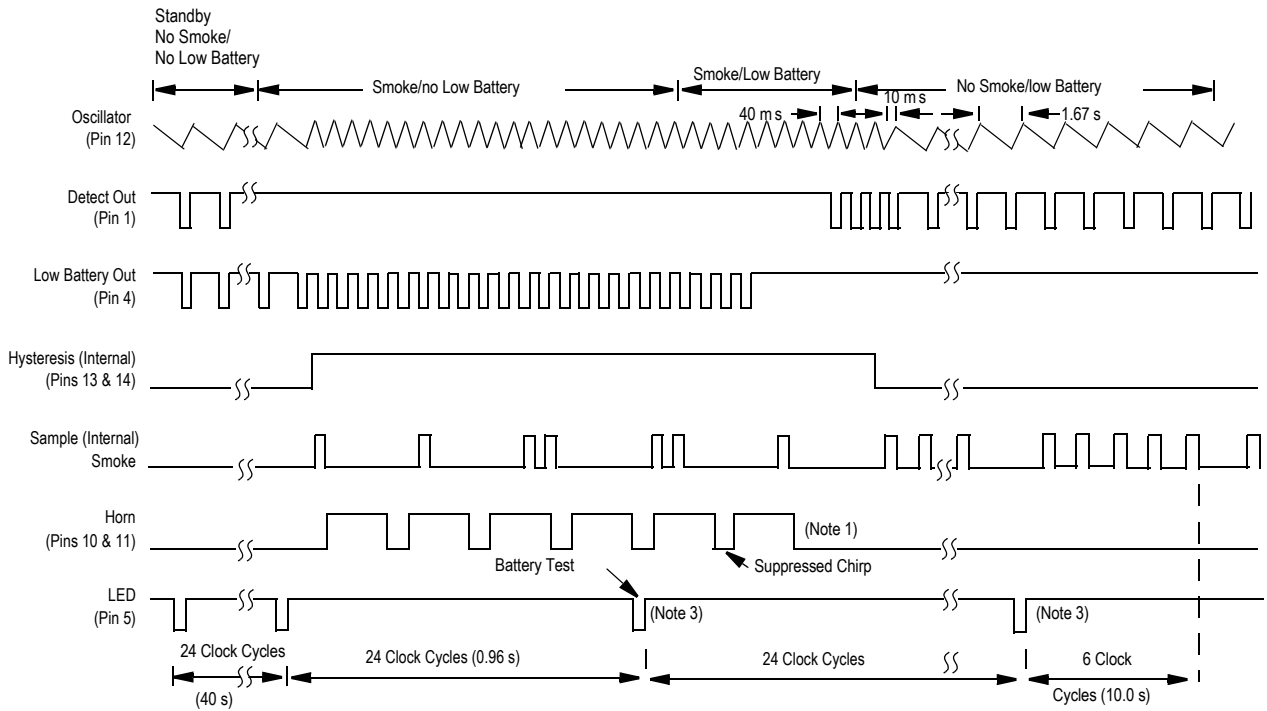

Notes:

1. Horn modulation is self-completing. When going from smoke to no smoke, the alarm condition will terminate only when horn is off.
2. Comparators are strobed on once per clock cycle (1.67 s for no smoke, 40 ms for smoke).
3. Low battery comparator information is latched only during LED pulse.
4. ~ 100 mVp-p swing.

Figure 7. Timing Diagram

**PACKAGE DIMENSIONS**

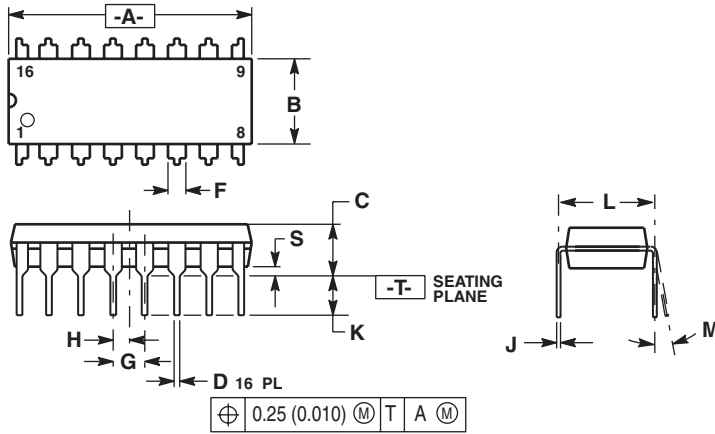

$\varnothing$	0.25 (0.010)	M	T	A	M
---------------	--------------	---	---	---	---

- |                |                     |
|----------------|---------------------|
| STYLE 1:       | STYLE 2:            |
| PIN 1. CATHODE | PIN 1. COMMON DRAIN |
| 2. CATHODE     | 2. COMMON DRAIN     |
| 3. CATHODE     | 3. COMMON DRAIN     |
| 4. CATHODE     | 4. COMMON DRAIN     |
| 5. CATHODE     | 5. COMMON DRAIN     |
| 6. CATHODE     | 6. COMMON DRAIN     |
| 7. CATHODE     | 7. COMMON DRAIN     |
| 8. CATHODE     | 8. COMMON DRAIN     |
| 9. ANODE       | 9. GATE             |
| 10. ANODE      | 10. SOURCE          |
| 11. ANODE      | 11. GATE            |
| 12. ANODE      | 12. SOURCE          |
| 13. ANODE      | 13. GATE            |
| 14. ANODE      | 14. SOURCE          |
| 15. ANODE      | 15. GATE            |
| 16. ANODE      | 16. SOURCE          |

NOTES:

1. DIMENSIONING AND TOLERANCING PER ANSI Y14.5M, 1982.
2. CONTROLLING DIMENSION: INCH.
3. DIMENSION L TO CENTER OF LEADS WHEN FORMED PARALLEL.
4. DIMENSION B DOES NOT INCLUDE MOLD FLASH.
5. ROUNDED CORNERS OPTIONAL.

DIM	INCHES		MILLIMETERS	
	MIN	MAX	MIN	MAX
A	0.740	0.770	18.80	19.55
B	0.250	0.270	6.35	6.85
C	0.145	0.175	3.69	4.44
D	0.015	0.021	0.39	0.53
F	0.040	0.70	1.02	1.77
G	0.100 BSC		2.54 BSC	
H	0.050 BSC		1.27 BSC	
J	0.008	0.015	0.21	0.38
K	0.110	0.130	2.80	3.30
L	0.295	0.305	7.50	7.74
M	0	10	0	10
S	0.020	0.040	0.51	1.01

**CASE 648-08  
ISSUE R  
16-LEAD PLASTIC DIP**

Archive Information

Archive Information

**How to Reach Us:**

**Home Page:**  
www.freescale.com

**E-mail:**  
support@freescale.com

**USA/Europe or Locations Not Listed:**  
Freescale Semiconductor  
Technical Information Center, CH370  
1300 N. Alma School Road  
Chandler, Arizona 85224  
+1-800-521-6274 or +1-480-768-2130  
support@freescale.com

**Europe, Middle East, and Africa:**  
Freescale Halbleiter Deutschland GmbH  
Technical Information Center  
Schatzbogen 7  
81829 Muenchen, Germany  
+44 1296 380 456 (English)  
+46 8 52200080 (English)  
+49 89 92103 559 (German)  
+33 1 69 35 48 48 (French)  
support@freescale.com

**Japan:**  
Freescale Semiconductor Japan Ltd.  
Headquarters  
ARCO Tower 15F  
1-8-1, Shimo-Meguro, Meguro-ku,  
Tokyo 153-0064  
Japan  
0120 191014 or +81 3 5437 9125  
support.japan@freescale.com

**Asia/Pacific:**  
Freescale Semiconductor Hong Kong Ltd.  
Technical Information Center  
2 Dai King Street  
Tai Po Industrial Estate  
Tai Po, N.T., Hong Kong  
+800 2666 8080  
support.asia@freescale.com

**For Literature Requests Only:**  
Freescale Semiconductor Literature Distribution Center  
P.O. Box 5405  
Denver, Colorado 80217  
1-800-441-2447 or 303-675-2140  
Fax: 303-675-2150  
LDCForFreescaleSemiconductor@hibbertgroup.com

Information in this document is provided solely to enable system and software implementers to use Freescale Semiconductor products. There are no express or implied copyright licenses granted hereunder to design or fabricate any integrated circuits or integrated circuits based on the information in this document.

Freescale Semiconductor reserves the right to make changes without further notice to any products herein. Freescale Semiconductor makes no warranty, representation or guarantee regarding the suitability of its products for any particular purpose, nor does Freescale Semiconductor assume any liability arising out of the application or use of any product or circuit, and specifically disclaims any and all liability, including without limitation consequential or incidental damages. "Typical" parameters that may be provided in Freescale Semiconductor data sheets and/or specifications can and do vary in different applications and actual performance may vary over time. All operating parameters, including "Typicals", must be validated for each customer application by customer's technical experts. Freescale Semiconductor does not convey any license under its patent rights nor the rights of others. Freescale Semiconductor products are not designed, intended, or authorized for use as components in systems intended for surgical implant into the body, or other applications intended to support or sustain life, or for any other application in which the failure of the Freescale Semiconductor product could create a situation where personal injury or death may occur. Should Buyer purchase or use Freescale Semiconductor products for any such unintended or unauthorized application, Buyer shall indemnify and hold Freescale Semiconductor and its officers, employees, subsidiaries, affiliates, and distributors harmless against all claims, costs, damages, and expenses, and reasonable attorney fees arising out of, directly or indirectly, any claim of personal injury or death associated with such unintended or unauthorized use, even if such claim alleges that Freescale Semiconductor was negligent regarding the design or manufacture of the part.

Freescale™ and the Freescale logo are trademarks of Freescale Semiconductor, Inc. All other product or service names are the property of their respective owners.

© Freescale Semiconductor, Inc. 2005. All rights reserved.

