

Product Preview

USB Hub Controller
CMOS

MC141555

This device is a self-contained USB Hub which complies with USB Hub Specification Rev 1.0. This device is used to expand the USB ports of your PC system while needed. Because of its self-contained and bus-powered/self-powered capability, it can hide the complexity from the user and be flexibly placed anywhere, such as monitor, keyboard, motherboard, Hub-box, etc. The MC141555 consists of Serial Interface Engine (SIE), Hub Repeater, and Hub Controller, supporting one upstream port and up to five downstream ports.

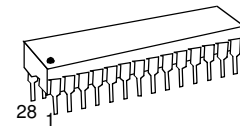

P SUFFIX
PLASTIC PACKAGE
CASE 655

ORDERING INFORMATION
MC141555P1 Plastic Dip

Both Low Speed Mode (1.5Mbps) and Full Speed Mode (12Mbps) are supported by automatically detecting which data line (D+ or D-) is pulled high whenever downstream devices are connected to the bus or at power-up.

MC141555 Hub can be Self Powered or Bus Powered. When self-powered, MC141555 is powered by an external 5 volt supply and capable of deliver 500mA current to each downstream port. Power management for all downstream ports supports power-switching and overcurrent detection with Individual or Ganged control; a self-powered MC141555 supports Individual control only, but bus-powered MC141555 supports either Individual or Ganged control. When Ganged control, PWRSW1 and OVR1 are dedicated for power management.

PIN ASSIGNMENT

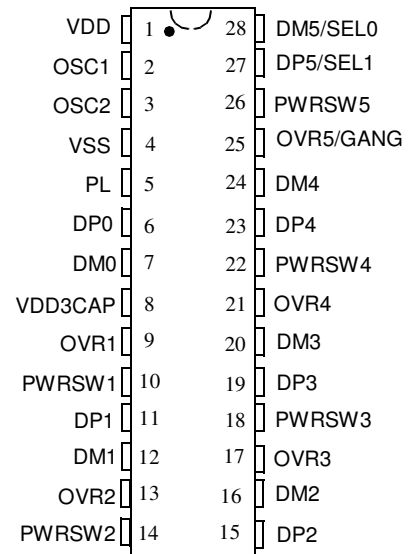

Features Highlight

Hub

- Self-contained Hub Includes Serial Interface Engine (SIE), Hub Repeater and Hub Controller
- Universal Serial Bus (USB) Version 1.0 Compliant
- Self-powered or Bus-powered
- Individual/Ganged Downstream Port Power Switching
- Individual/Ganged Downstream Port Overcurrent Detection
- All Downstream Ports Support Full Speed and Low Speed Operation
- Suspend and Resume Operations
- Host Reset Operation

General Characteristics

- 28 DIP Package
- Crystal Input 24MHz
- Internal 3.3Volt Regulator
- Single 5Volt Power Supply
- Low-power CMOS Technology

RoHS-compliant and/or Pb-free versions of Freescale products have the functionality and electrical characteristics of their non-RoHS-compliant and/or non-Pb-free counterparts. For further information, see <http://www.freescale.com> or contact your Freescale sales representative.

For information on Freescale's Environmental Products program, go to <http://www.freescale.com/epp>.



Figure 1. BLOCK DIAGRAM

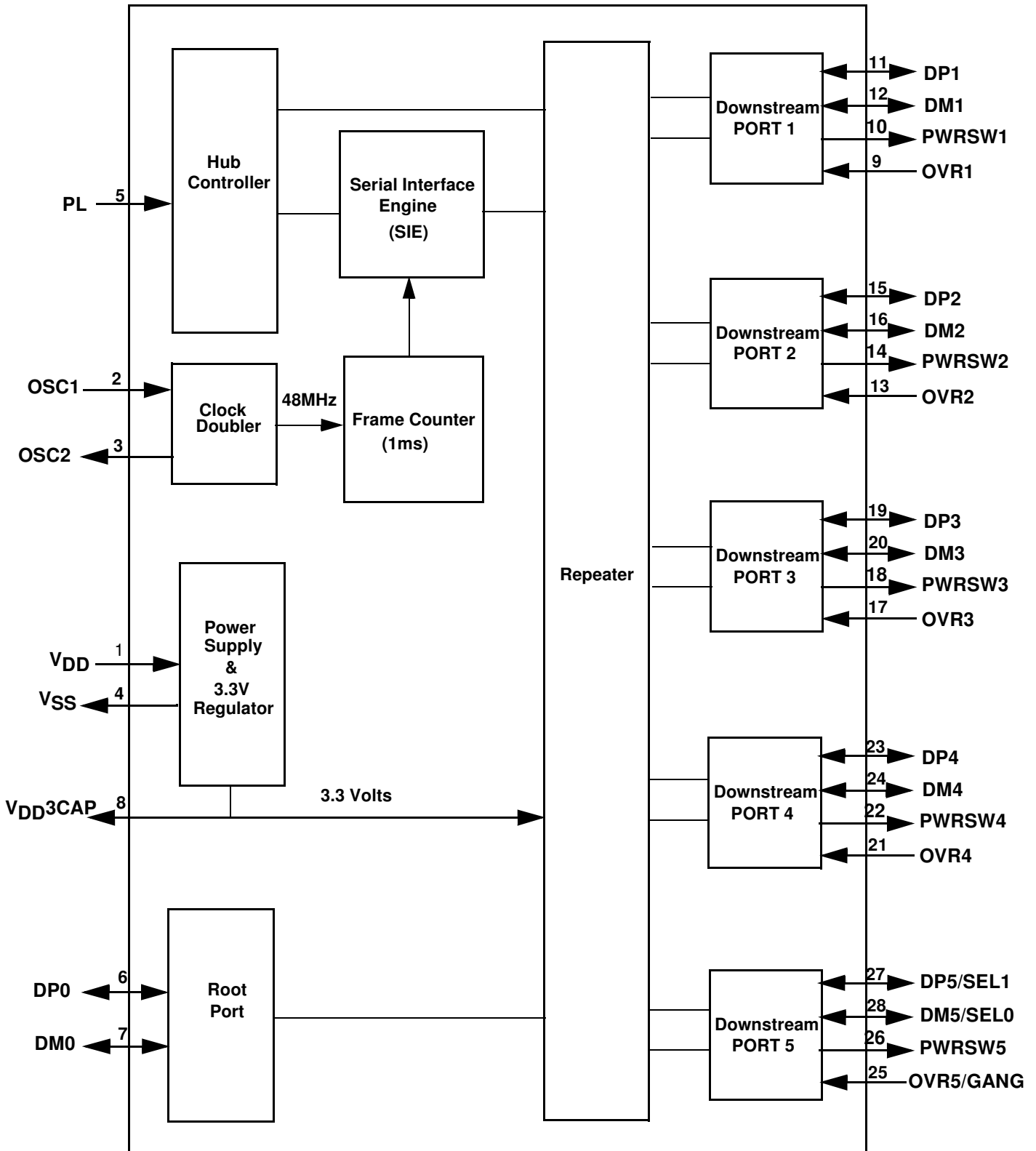

Freescale Semiconductor, Inc.

ABSOLUTE MAXIMUM RATINGS Voltage Referenced to V_{SS}

Symbol	Characteristic	Value	Unit
V _{DD}	Supply Voltage	- 0.3 to + 7.0	V
V _{in}	Input Voltage	V _{SS} - 0.3 to V _{DD} + 0.3	V
I _d	Current Drain per Pin Excluding V _{DD} and V _{SS}	25	mA
T _a	Operating Temperature Range	0 to 85	°C
T _{stg}	Storage Temperature Range	- 65 to + 150	°C

NOTE: Maximum Ratings are those values beyond which damage to the device may occur. Functional operation should be restricted to the limits in the Electrical Characteristics tables or Pin Description section.

This device contains protection circuitry to guard against damage due to high static voltages or electric fields. However, precautions must be taken to avoid applications of any voltage higher than maximum rated voltages to this high-impedance circuit. For proper operation, V_{in} and V_{out} should be constrained to the range V_{SS} ≤ (V_{in} or V_{out}) ≤ V_{DD}.

Unused inputs must always be tied to an appropriate logic voltage level (e.g., either V_{SS} or V_{DD}). Unused outputs must be left open.

AC ELECTRICAL CHARACTERISTICS (V_{DD}/V_{DD(A)} = 5.0 V, V_{SS}/V_{SS(A)} = 0 V, T_A = 25°C,

Voltage Referenced to V_{SS})

FULL SPEED MODE CHARACTERISTICS

Symbol	Parameter	Conditions	Min	Max	Unit
t _r	Rise Time for DP/DM	C _{load} = 50 pF	4	20	ns
t _f	Fall Time for DP/DM	C _{load} = 50 pF	4	20	ns
t _{RFM}	Rise/Fall Time Matching	(t _r /t _f) × 100	90	110	%
V _{CRS}	Output Signal Crossover Voltage	—	1.3	2.0	V

LOW SPEED MODE CHARACTERISTICS

Symbol	Parameter	Conditions	Min	Max	Unit
t _r	Rise Time for DP/DM	C _{load} = 50 pF to 350 pF	75	300	ns
t _f	Fall Time for DP/DM	C _{load} = 50 pF to 350 pF	75	300	ns
t _{RFM}	Rise/Fall Time Matching	(t _r /t _f) × 100	80	120	%
V _{CRS}	Output Signal Crossover Voltage	—	1.3	2.0	V

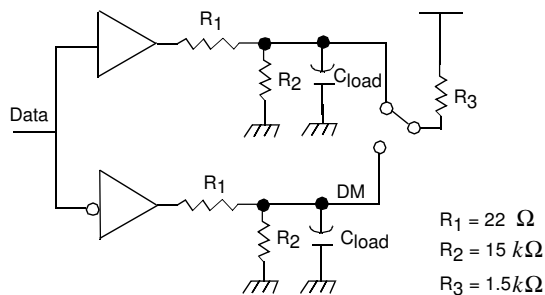

Figure 2. Differential Driver Switching Load

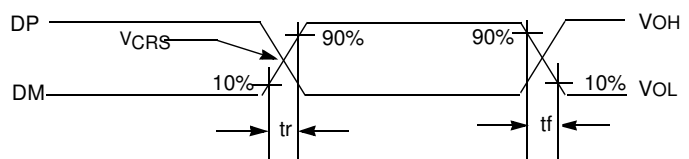

Figure 3. Differential Driver Switching Characteristics

DC CHARACTERISTICS $V_{DD}/V_{DD(A)} = 5.0\text{ V} \pm 10\%$, $V_{SS}/V_{SS(A)} = 0\text{ V}$, $T_A = 25^\circ\text{C}$, Voltage Referenced to V_{SS}

Symbol	Parameter	Conditions	Min	Max	Unit
V_{BUS}	Powered (Host or Hub) Port	—	4.65	5.25	V
V_{BUS}	Bus-powered Hub Port	—	4.40	5.25	V
V_{OH}	High Level Output Voltage	—	2.8	3.6	V
V_{OL}	Low Level Output Voltage	—	—	0.3	V
V_{IL} V_{IH}	Digital Input Voltage Logic Low Logic High	—	— $0.7 V_{DD}$	$0.3 V_{DD}$ —	V V
I_{II}	High-Z Leakage Current (output pins)	—	-10	+10	μA
I_{II}	Input Current	—	-10	+10	μA
I_{DD}	Supply Current (No Load on Any Output)	—	—	+25	mA
I_{CCINIT}	Unconfig. Function/Hub (in)	—	—	100	mA
V_{DI}	Differential Input Sensitivity	$ (D+) - (D-) $ Refer to Figure 4	0.2	—	V
V_{CM}	Differential Common Mode Range	Includes V_{DI} range	0.8	2.5	V
V_{SE}	Single Ended Receiver Threshold	—	0.8	2.0	V
C_{HPB}	Downstream Hub Port Bypass Capacitance	V_{bus} to GND	120	—	μF

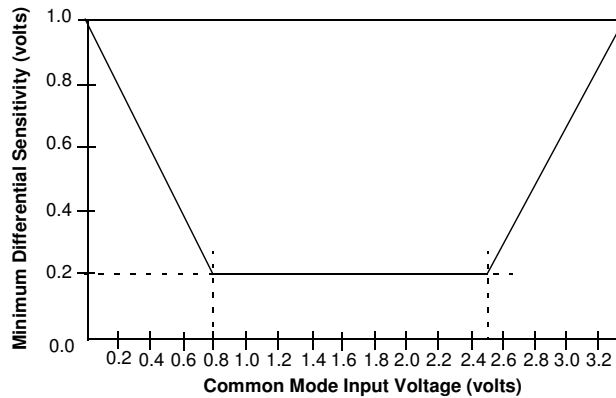

Figure 4. Differential Input Sensitivity Over Entire Common Mode Range

FULL SPEED OPERATING HUB ELECTRICAL CHARACTERISTICS

Symbol	Parameter	Conditions	Min	Max	Unit
t_{HDD1} t_{HDD2}	Hub Differential Data Delay (with cable) (without cable)	Figure 5, Figure 6	— —	70 40	ns ns
t_{HDJ1} t_{HDJ2}	Hub Differential Driver Jitter (including cable) To Next Transition For Paired Transitions	—	-3 -1	3 1	ns ns
t_{SOP}	Data Bit Width Distortion After SOP	—	-5	3	ns
t_{HESK}	Hub EOP Output Width Skew	—	-15	15	ns

LOW SPEED OPERATING HUB ELECTRICAL CHARACTERISTICS

Symbol	Parameter	Conditions	Min	Max	Unit
t_{LHDD}	Hub Differential Data Delay	Figure 5, Figure 6	—	300	ns
t_{LDHJ1} t_{LDHJ2}	Hub Differential Driver Jitter (including cable) Downstream: To Next Transition For Paired Transitions	—	-45 -15	45 15	ns ns
t_{LDHJ2} t_{LDHJ2}	Upstream: To Next Transition For Paired Transitions	—	-45 -45	45 45	ns ns
t_{SOP}	Data Bit Width Distortion After SOP	—	-60	45	ns
t_{LHESK}	Hub EOP Output Width Skew	—	-300	300	ns

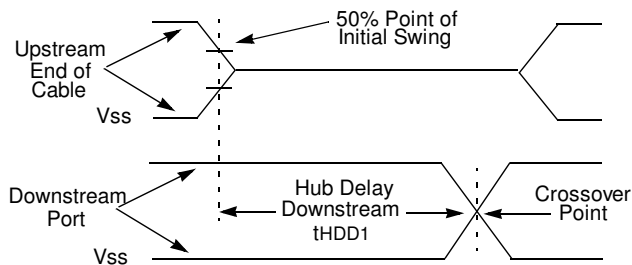

Figure 5. Downstream Hub Delay

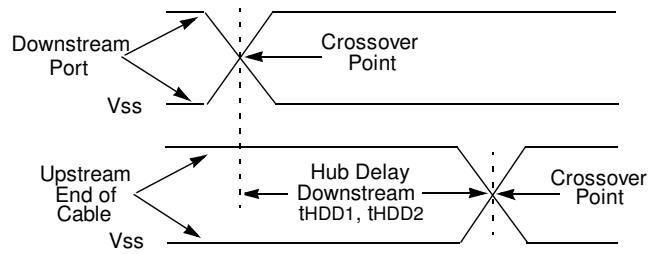

Figure 6. Upstream Hub Delay

PIN DESCRIPTION

V_{DD} (Pin 1)

This is the +5V power pin of the chip.

OSC1 (Pin 2), OSC2 (Pin 3)

The OSC1 and OSC2 pins are the connections for the on-chip oscillator. The crystal frequency is 24MHz. OSC1 may be driven by an external oscillator if an external crystal circuit is not used.

V_{SS} (Pin 4)

This is the ground pin of the chip.

PL (Pin 5)

This pin requires to be pulled low to GND.

DP0 (Pin 6)

This is the upstream differential data plus I/O pin of the Hub.

DM0 (Pin 7)

This is the upstream differential data minus I/O pin of the Hub.

V_{DD3CAP} (Pin 8)

This pin must connect an external capacitor for the internal 3.3V regulator which supply transceivers of all USB ports.

OVR1 (Pin 9)

This is the over-current detection pin of the downstream port 1. Active low is to indicate overcurrent condition occurs. In GANG mode, OVR1 is the common detection pin for all the four downstream ports.

PWRSW1 (Pin 10)

This is an output pin which can be used to switch on/off the external power regulator for the downstream port 1. Active high is to switch on the power. In GANG mode, PWRSW1 is the common output pin for all the four downstream ports.

DP1 (Pin 11)

This is the differential data plus I/O pin of the downstream port 1.

DM1 (Pin 12)

This is the differential data minus I/O pin of the downstream port 1.

OVR2 (Pin 13)

This is the over-current detection pin of the downstream port 2. Active low is to indicate overcurrent condition occurs.

PWRSW2 (Pin 14)

This is an output pin which can be used to switch on/off the external power regulator for the downstream port 2. Active high is to switch on the power.

DP2 (Pin 15)

This is the differential data plus I/O pin of the downstream port 2.

DM2 (Pin 16)

This is the differential data minus I/O pin of the downstream port 2.

OVR3 (Pin 17)

This is the over-current detection pin of the downstream port 3. Active low is to indicate overcurrent condition occurs.

PWRSW3 (Pin 18)

This is an output pin which can be used to switch on/off the external power regulator for the downstream port 3. Active high is to switch on the power.

DP3 (Pin 19)

This is the differential data plus I/O pin of the downstream port 3.

DM3 (Pin 20)

This is the differential data minus I/O pin of the downstream port 3.

OVR4 (Pin 21)

This is the over-current detection pin of the downstream port 4. Active low is to indicate overcurrent condition occurs.

PWRSW4 (Pin 22)

This is an output pin which can be used to switch on/off the external power regulator for the downstream port 4. Active high is to switch on the power.

DP4 (Pin 23)

This is the differential data plus I/O pin of the downstream port 4.

DM4 (Pin 24)

This is the differential data minus I/O pin of the downstream port 4.

OVR5/GANG (Pin 25)

In self-powered mode, this input pin acts as OVR5, which is overcurrent detection of downstream port 5; active low is to indicate overcurrent occurs.

In bus-powered mode, this input pin acts as GANG to determine Power Control Mode; pulling this pin low configures the Hub as Ganged control, and pulling it high as Individual control.

PWRSW5 (Pin 26)

In self-powered mode, this output pin is to switch on/off the external power regulator for downstream port 5; active high is to switch on the power.

DP5/SEL1 (Pin 27)

In initialization, this pin, along with SEL0 and OVR5, determines Power Mode and Power Control Mode. (refer to Table1 for detail) After initialization, if self-powered, this pin is differential data plus I/O pin of downstream port 5.

DM5/SEL0 (Pin 28)

In initialization, this pin, along with SEL1 and OVR5, determines Power Mode and Power Control Mode. (refer to Table1 for detail) After initialization, if self-powered, this pin is differential data minus I/O pin of downstream port 5; if bus-powered, pull this pin high.

SYSTEM DESCRIPTION

MC141555 is booted up from the Power-On Reset which will initialize all the internal hardware circuitry and reset the program counter of the internal processor. During Power-On Reset, MC141555 must be set to the desired configuration by the input states of the pins, OVR5/GANG, PWRSW5, DP5/SEL1 and DM5/SEL0. See **Table 1 Configuration Selection** for detail.

After Power-On, the Hub Repeater will handle the connectivity in per packet basis, and all downstream ports transition to the powered off state. After all initialization, the Hub Controller takes over the responsibility for receiving Host's commands, Downstream Power Management and to report status in per port basis while Repeater is detecting the connectivity of each downstream port.

MC141555 accepts the Host Reset request to generate a per port reset and receives reset signalling from root port to complete its own reset sequence.

HUB CONFIGURATION

MC141555 can be configured as one of the three operating modes: Self Power Mode with Individual Control, Bus Power Mode with Individual Control and Bus Power Mode with Ganged Control.

(a) Self-powered Mode with Individual Control (Monitor Application)

During Power-On Reset, pull DP5/SEL1 and DM5/SEL0 low to select this mode. Meanwhile, MC141555 is configured to be self powered with 5 downstream ports whose power management is in Individual Control; that is, after Power-On Reset, DP5/SEL1 acts as DP5, DM5/SEL0 acts as DM 5 and OVR5/GANG acts as OVR5 .

(b) Bus-powered Mode with Individual Control

During Power-On Reset, pull DP5/SEL1 low, pull OVR5/GANG and DM5/SEL0 high to select this mode. Meanwhile, MC141555 is configured to be bus powered with 4 downstream ports whose power management is in Individual Control; that is, after Power-On Reset, DP5/SEL1, DM5/SEL0, OVR5/GANG and PWRSW5 have no further usage.

(c) Bus-powered Mode with Ganged Control

During Power-On Reset, pull DP5/SEL1 and OVR5/GANG low and pull DM5/SEL0 high to select this mode. Meanwhile, MC141555 is configured to be bus-powered with 4 downstream ports whose power management is in Ganged Control. In this mode, only PWRSW1 and OVR1 are dedicated to power management for all 4 downstream ports.

All three operating modes with pin input states during Power-On Reset are summarized in Table 1.

Table 1. Configuration Selection

DP5/SEL1	DM5/SEL0	PWRSW5	OVR5/GANG	Configuration
0	0	PWRSW5	OVR5	Self Power & Individual Control
0	1	X	1	Bus Power & Individual Control
0	1	X	0	Bus Power & Ganged Control

X: don't care

DESCRIPTOR

The Hub Controller supports the following standard USB descriptors and one Hub specific descriptor.

Table2. Device Descriptor

Offset	Field	Size	Value	Description
0	bLength	1	12h	No. of bytes in this descriptor = 18
1	bDescriptorType	1	01h	Device descriptor type
2	bcdUSB	2	0100h	USB Spec. Release Number = Rev 1.00
4	bDeviceClass	1	09h	Class code
5	bDeviceSubClass	1	00h	Subclass code
6	bDeviceProtocol	1	00h	Protocol code
7	wMaxPacketSize0	1	08h	Max. packet size for Endpoint 0 = 8
8	idVendor	2	1063h	Vendor ID = Motorola Corporation (assigned by USB)
10	idProduct	2	1555h	Product ID = MC141555
12	bcdDevice	2	0100h	Device Release No. = 1.00
14	iManufacturer	1	00h	Manufacturer string descriptor = Open
15	iProduct	1	00h	Product string descriptor = Open
16	iSerialNumber	1	00h	Serial Number string = Open
17	bNumConfigurations	1	01h	No. of possible configurations = 1

Table 3. Configuration Descriptor

Offset	Field	Size	Value	Description
0	bLength	1	09h	No. of bytes in this descriptor = 9
1	bDescriptorType	1	02h	Configuration descriptor type
2	wTotalLength	2	0019h	Total length of data returned for this configuration. Includes configuration, interface, endpoint, and class specific descriptors
4	bNumInterfaces	1	01h	No. of interfaces supported in this configuration = 1
5	bConfigurationValue	1	01h	Value to use as an argument to select this configuration =1
6	iConfiguration	1	00h	Index of string descriptor describing this configuration
7	bmAttributes	1	60h/A0h	Configuration characteristics 60h: SelfPowered, RemoteWakeup A0h: BusPowered, RemoteWakeup
8	MaxPower	1	01/FAh	Maximum power consumption of USB device from the bus: 01h: 2mA when self-powered FAh: 500mA when bus-powered

Table 4. Interface Descriptor

Offset	Field	Size	Value	Description
0	bLength	1	09h	No. of bytes in this descriptor = 9
1	bDescriptorType	1	04h	Interface descriptor type
2	bInterfaceNumber	1	00h	No. of Interface = 0
3	bAlternateSetting	1	00h	Alternate setting value for the interface identified in the prior field = 0
4	bNumEndpoints	1	01h	No. of endpoints used by this interface = 1
5	bInterfaceClass	1	09h	Class code = 09 (assigned by USB)
6	bInterfaceSubClass	1	00h	SubClass code = 01 (assigned by USB)
7	bInterfaceProtocol	1	00h	Protocol code = 00 (assigned by USB)
8	iInterface	1	00h	Index of string descriptor describing this interface = 0

Table 5. Endpoint Descriptor

Offset	Field	Size	Value	Description
0	bLength	1	07h	No. of bytes in this descriptor = 7
1	bDescriptorType	1	05h	Endpoint descriptor type
2	bEndpointAddress	1	81h	Endpoint No. = 1, IN endpoint
3	bmAttributes	1	03h	Endpoint attributes = b00000011, Transfer type = Interrupt
4	wMaxPacketSize	2	0001h	Max. packet size this endpoint is capable of sending = 1 byte
6	bInterval	1	FFh	Interval for polling endpoint for data transfer = 255 ms

Table 6. Hub Descriptor

Offset	Field	Size	Value	Description
0	bLength	1	09h	No. of bytes in this descriptor = 9
1	bDescriptorType	1	29h	Hub descriptor type
2	bNbrPorts	1	04h/05h	No. of downstream ports
3	wHubCharacteristics	2	0000h / 0004h/ 0009h/ 000Dh	Hub's characteristics Power Switching Mode: BIT1..BIT0 = 00: Ganged Power Switching BIT1..BIT0 = 01: Individual Port Power Switching Compound Device: BIT2=0: Not Compound Device BIT2=1: Compound Device Overcurrent Protection Mode: BIT4..BIT3=00: Global Overcurrent Protection BIT4..BIT3=01: Individual Port Overcurrent Protection
5	bPwrOn2PwrGood	1	32h	Time from the power on to power good = 100 ms
6	bHubContrCurrent	1	64h	Maximum current requirements of the Hub controller electronics 64h: 100 mA

Offset	Field	Size	Value	Description
7	DeviceRemovable	1	00h/20h	00h: Indicate all the ports connected to this Hub are removable. 02h: Indicate Port5 is dedicated to internal use and permanent attached.
8	PortPwrCtrlMask	1	3Eh/ 1Eh/ 00h	Indicates all the ports connected to this Hub are not affected by a Ganged-mode power request, Ports always require SetPortFeature (PORT_POWER) to control the port's power state. 3Eh: 5 downstream ports are individual-controlled 1Eh: 4 downstream ports are individual-controlled 00h: all downstream ports are ganged-controlled

STATUS CHANGE REGISTER

The additional endpoint 1 of the Hub Controller supports interrupt transfer which reports the Hub and Port Status Change Register, as shown in following table. This register contains only one byte.

Table 7. Status Change Register

Bit	Function	Value	Description
0	Hub status change	0	No status change in Hub
		1	Hub status change detected
1	Port 1 status change	0	No status change in Port 1
		1	Port 1 status change detected
2	Port 2 status change	0	No status change in Port 2
		1	Port 2 status change detected
3	Port 3 status change	0	No status change in Port 3
		1	Port 3 status change detected
4	Port 4 status change	0	No status change in Port 4
		1	Port 4 status change detected
5	Port 5 status change	0	No status change in Port 5
		1	Port 5 status change detected
6-7	Reserved	00	Default values

REQUEST

The Hub Controller will respond to the HOST Request through the endpoint 0 pipe in the way as illustrated in following tables. If the Hub responses with STALL packet, it means the request is not supported.

Freescale Semiconductor, Inc.

Table 8. Standard Requests

bmRequestType	bRequest	wValue	wIndex	wLength	Data/Handshake
0000000b (device)	01h Clear_Feature	0001h	0000h	0000h	None/Ack Disable remote wakeup feature
0000001b (interface)		xxxxh	xxxxh	xxxxh	STALL
0000010b (endpoint)		0000h	0000h (e.p. 0) 0081h (e.p. 1)	0000h	None/Ack Clear Endpoint Stall condition
1000000b	08h Get_Configuration	0000h	0000h	0001h	ConfigurationValue
1000000b	06h Get_Descriptor	0100h 0200h 0400h 0500h	0000h	0012h 0019h xxxx xxxx	Device Descriptor Configuration Descriptor STALL STALL
1000001b	0Ah Get_Interface	0000h	0001h	0001h	00h
1000000b (device)	00h Get_Status	0000h	0000h	0002h	current Remote Wakeup/ Powered status
1000001b (interface)			xxxxh		0000h
1000010b (endpoint)			0000h 0081h		0001h = STALLED 0000h = not STALLED
0000000b	05h Set_Address	Device address	0000h	0000h	None/Ack
0000000b	09h Set_Configuration	0000h/ 0001h	0000h	0000h	None/Ack
0000000b	07h Set_Descriptor	xxxxh	xxxxh	xxxxh	xxxx/STALL
0000000b (device)	03h Set_Feature	0001h	0000h	0000h	None/Ack Enable remote wakeup feature
0000001b (interface)		xxxxh	xxxxh	xxxxh	None/STALL
0000010b (endpoint)		0000h	0000h (e.p. 0) 0081h (e.p. 1)	0000h	None/ACK Set Endpoint STALL condition
0000001b	0Bh Set_Interface	0000h	0000h	0000h	None/Ack
1000010b	0Ch Synch_Frame	xxxxh	xxxxh	xxxxh	STALL

Freescale Semiconductor, Inc.

Table 9. Hub Class-specific Request

bmRequestType	bRequest	wValue	wIndex	wLength	Data/Handshake
00100000b ClearHubFeature C_HubLocalPower C_HubOverCurrent	01h Clear_Feature	Feature Selector 0000h 0001h	0000h	0000h	None/Ack
00100011b ClearPortFeature Port_Connection Port_Enable Port_Suspend Port_Over_Current Port_Reset Port_Power Port_Low_Speed C_Port_Connection C_Port_Enable C_Port_Suspend C_PortOverCurrent C_Port_Reset	01h Clear_Feature	Feature Selector 0000h 0001h 0002h 0003h 0004h 0008h 0009h 0010h 0011h 0012h 0013h 0014h	0001h ~ 0005h	0000h	None/Ack STALL STALL STALL STALL
10100011b GetBusState	02h Get_State	0000h	0001h ~ 0005h	0001h	Bus State per Port
10100000b GetHubDescriptor	06h Get_Descriptor	0000h	0000h	0009h	Hub Descriptor
10100000b GetHubStatus	00h Get_Status	0000h	0000h	0004h	00000000000000OPb, 00000000000000opb O: Over Current indicator P: Local Power status o: C_Hub_Over_Current p: C_Hub_Local_Power
10100011b GetPortStatus	00h Get_Status	0000h	0001h ~ 0005h	0004h	000000LP000ROSECb, 000000000000rosecb L: Port_Low_Speed P: Port_Power R: Port_Reset O: Port_Over_Current S: Port_Suspend E: Port_Enable C: Port_Connection r: C_Port_Reset o: C_Port_Over_Current s: C_Port_Suspend e: C_Port_Enable c: C_Port_Connection

Freescale Semiconductor, Inc.

Freescale Semiconductor, Inc.

bmRequestType	bRequest	wValue	wIndex	wLength	Data/Handshake
00100000b SetHubDescriptor	07h Set_Descriptor	xxxxh	xxxxh	xxxxh	STALL
00100000b SetHubFeature C_HubLocalPower C_HubOverCurrent	03h Set_Feature	Feature Selector 0000h 0001h	0000h	0000h	STALL STALL STALL
00100011b SetPortFeature Port_Connection Port_Enable Port_Suspend Port_Over_Current Port_Reset Port_Power Port_Low_Speed C_Port_Connection C_Port_Enable C_Port_Suspend C_PortOverCurrent C_Port_Reset	03h Set_Feature	Feature Selector 0000h 0001h 0002h 0003h 0004h 0008h 0009h 0010h 0011h 0012h 0013h 0014h	0001h ~ 0005h	0000h	None/Ack STALL STALL STALL STALL STALL STALL STALL STALL STALL STALL

Freescale Semiconductor, Inc.

APPLICATION DIAGRAM (Mode Selection)

Table 10. MODE SELECTION

Application	Mode	DP5/SEL1	DM5/SEL0	PWRSW5	OVR5/GANG
Monitor	Self-Powered & Individual Control	0	0	PWRSW5	OVR5
Hub Box	Self-Powered & Individual Control	0	0	PWRSW5	OVR5
	Bus-Powered & Individual Control	0	1	X	1
	Bus-Powered & Ganged Control	0	1	X	0

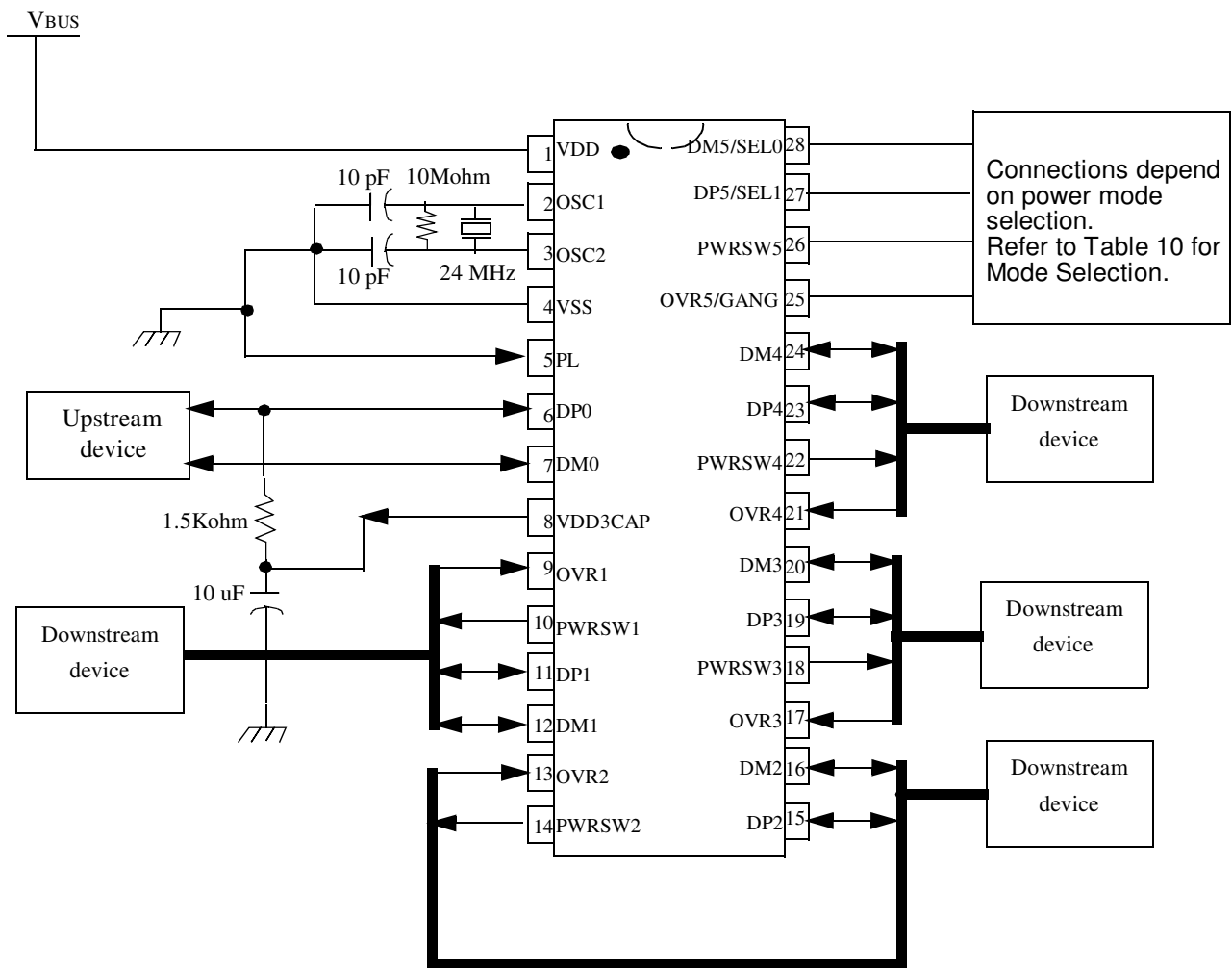

Freescale Semiconductor, Inc.

Freescale Semiconductor, Inc.
APPLICATION DIAGRAM (downstream port)

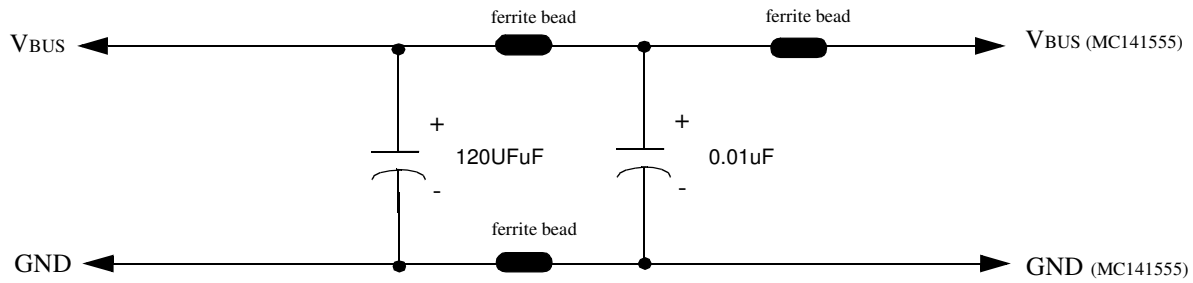
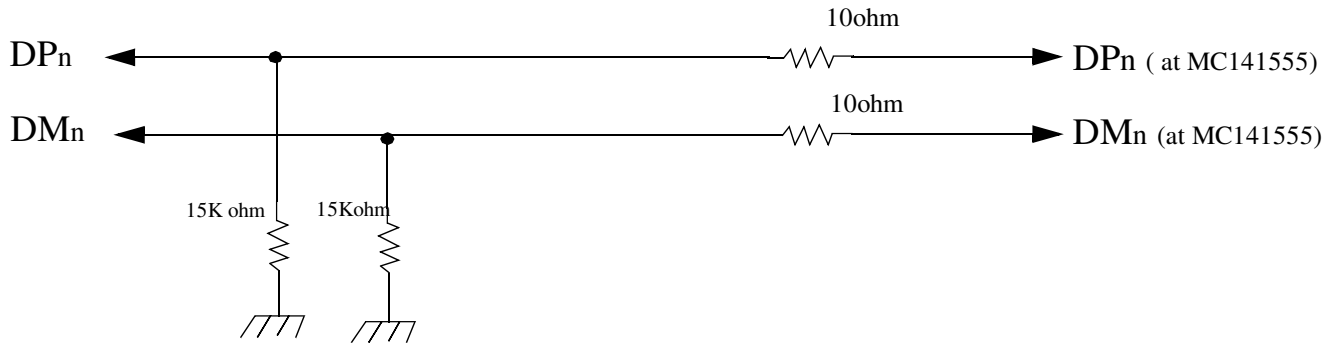

Freescale Semiconductor, Inc.

APPLICATION DIAGRAM (Pull-high circuit of upstream port)

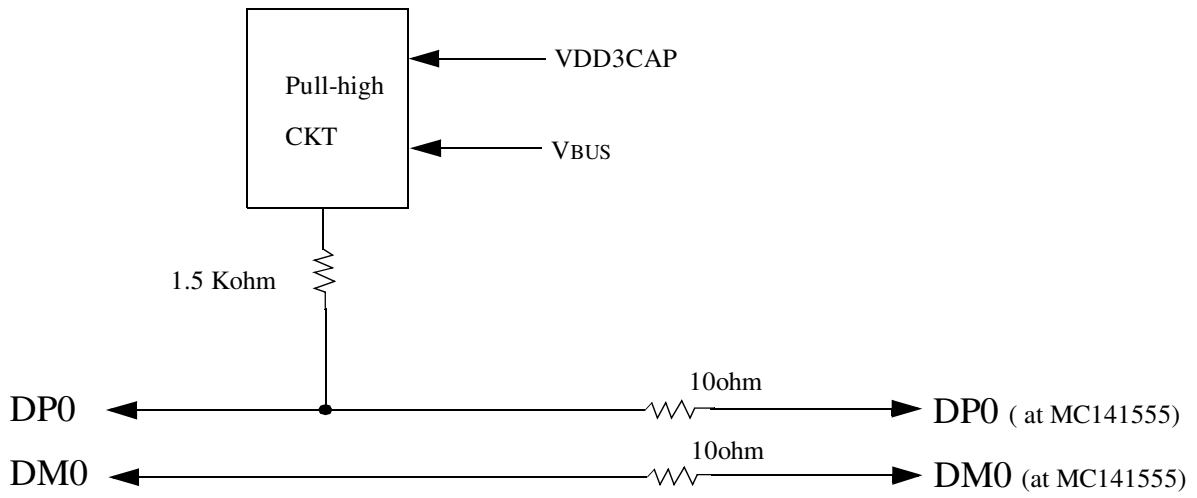

DP0 (upstream device)

