

# MC13770



(Scale 2:1)

## Package Information

Plastic Package

Case 1345

(QFN-12)

# MC13770

## Single Band LNA and Mixer FEIC

### Ordering Information

Device	Device Marking	Package
MC13770FC	770	QFN-12

## 1 Introduction

The MC13770 is a single band front-end IC designed for wireless receiver applications. It contains a low noise LNA and a high linearity mixer. The LNA is integrated with a bypass switch to preserve input intercept performance. The device is fabricated using Freescale's Advanced RF BiCMOS process using the SiGe:C option and is packaged in a 12 pin Quad Flat Non-leaded package.

### Contents

1	Introduction .....	1
2	Electrical Specifications .....	2
3	Contact Description .....	4
4	Applications Information .....	4
5	Packaging Information .....	7

### 1.1 Features

- RF Input Frequency: 2100 to 2400 MHz
- LNA Gain = 15 dB (Typ)
- LNA Input 3rd Order Intercept Point (IIP3) = 0 dBm (Typ)
- LNA Noise Figure (NF) = 1.5 dB (Typ)
- Bypass Mode Included for Improved Intercept Point Performance
- Double Balanced Mixer
- Mixer Conversion Gain = 10 dB (Typ)
- Mixer Noise Figure (NF) = 8.0 dB (Typ)

Freescale reserves the right to change the detail specifications as may be required to permit improvements in the design of its products.

© Freescale Semiconductor, Inc., 2003, 2005. All rights reserved.

## Electrical Specifications

- Mixer Input 3rd Order Intercept Point (IIP3) = -3.0 dBm (Typ)
- Total Supply Current = 8.0 mA  
 LNA = 3.0 mA  
 Mixer = 5.0 mA

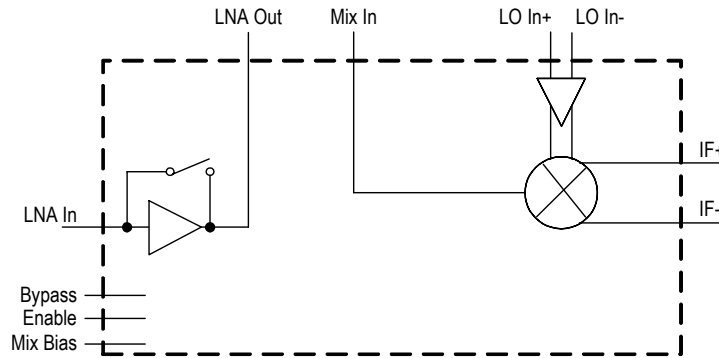

Figure 1. Simplified Block Diagram

## 2 Electrical Specifications

Table 1. Maximum Ratings

Rating	Symbol	Value	Unit
Supply Voltage	$V_{CC}$	3.6	V
Storage Temperature Range	$T_{stg}$	-65 to 150	°C
Operating Temperature Range	$T_A$	-40 to 85	°C

**Note:** Maximum Ratings and ESD

1. Maximum Ratings are those values beyond which damage to the device may occur. Functional operation should be restricted to the limits in the Electrical Characteristics tables or Pin Descriptions section.
2. ESD (electrostatic discharge) immunity meets Human Body Model (HBM)  $\leq 100$  V and Machine Model (MM)  $\leq 30$  V. Additional ESD data available upon request.

Table 2. Recommended Operating Conditions

Characteristic	Symbol	Min	Typ	Max	Unit
Supply Voltage		2.7	2.75	3.0	Vdc
Logic Voltage (Enable and Bypass Pins)					V
Input High Voltage		$0.85 V_{CC}$	-	$V_{CC}$	
Input Low Voltage		0	-	$0.15 V_{CC}$	

Table 3. Electrical Characteristics

Characteristic	Symbol	Min	Typ	Max	Unit
Turn-on Time		-	100	-	ns

**LNA High Gain Mode** (Frequency = 2140 MHz,  $V_{CC} = 2.75$  V, Bypass = 2.75 V, Enable = 2.75 V)

LNA Gain		-	15	-	dB
LNA Noise Figure		-	1.5	-	dB
LNA Input IP3		-	0	-	dBm
LNA Supply Current	$I_{DD}$	-	3.0	-	mA

**LNA Low Gain Mode** (RF = 2140 MHz,  $V_{CC} = 2.75$  V, Bypass = 0 V, Enable = 2.75 V)

LNA Gain		-	-5.0	-	dB
LNA Noise Figure		-	5.0	-	dB
LNA Input IP3		-	20	-	dBm
LNA Supply Current	$I_{DD}$	-	10	-	$\mu$ A

**Mixer Mode** (RF = 2140 MHz, LO = 2520 MHz,  $V_{CC} = 2.75$  Vdc, Enable = 2.75 V)

Conversion Gain		-	10	-	dB
SSB Noise Figure		-	8.0	-	dB
Input IP3		-	-3.0	-	dBm
Supply Current		-	5.0	-	mA
LO Drive Level		-	-10	-	dBm

**Note:** Tone spacing for IIP3 measurement is 5.0 MHz.

Table 4. Truth Table

(1 = 2.75 V, 0 = 0 V)

Enable	Bypass	Mode
0	0	Sleep
0	1	Undefined - do not use
1	0	Low Gain
1	1	High Gain

### 3 Contact Description

Table 5. Contact Function Description

Pin	Symbol	Description
1	LNA Out	LNA Output
2	Bypass	LNA Bypass Control
3	Mix In	Mixer Input
4	Enable	Chip Enable
5	LO+	Local Oscillator Input +
6	LO-	Local Oscillator Input -
7	IF+	Differential IF Output +
8	IF-	Differential IF Output -
9	V <sub>CC</sub>	Supply
10	LNA In	LNA Input
11	Gnd	Ground
12	Mix Bias	Mixer Bias Adjustment

### 4 Applications Information

Figure 2 shows the typical application circuit for 2110 to 2140 MHz band. The Mixer input is internally broadband matched. Two typical IF output match circuits are provided in Table 6 on page 5.

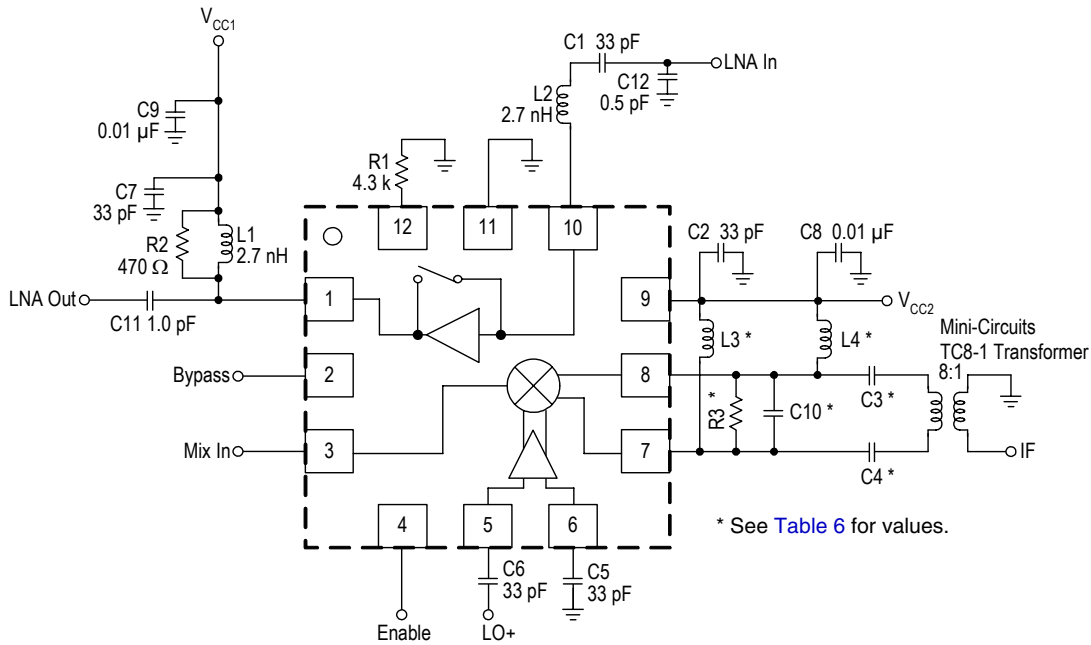

Figure 2. Application Schematic

Table 6. Bill of Material for Application Schematic

Component	190 MHz IF	380 MHz IF
C3	1.2 pF	2.2 pF
C4	1.2 pF	2.2 pF
C10	1.2 pF	1.2 pF
L3	150 nH	39 nH
L4	150 nH	39 nH
R3	5.0 kΩ	20 kΩ

Note: All other components are the same for both configurations.

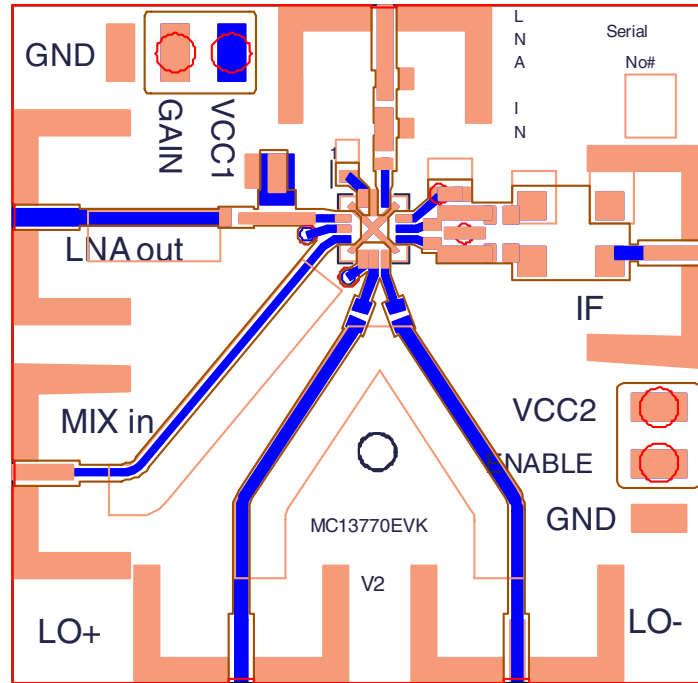
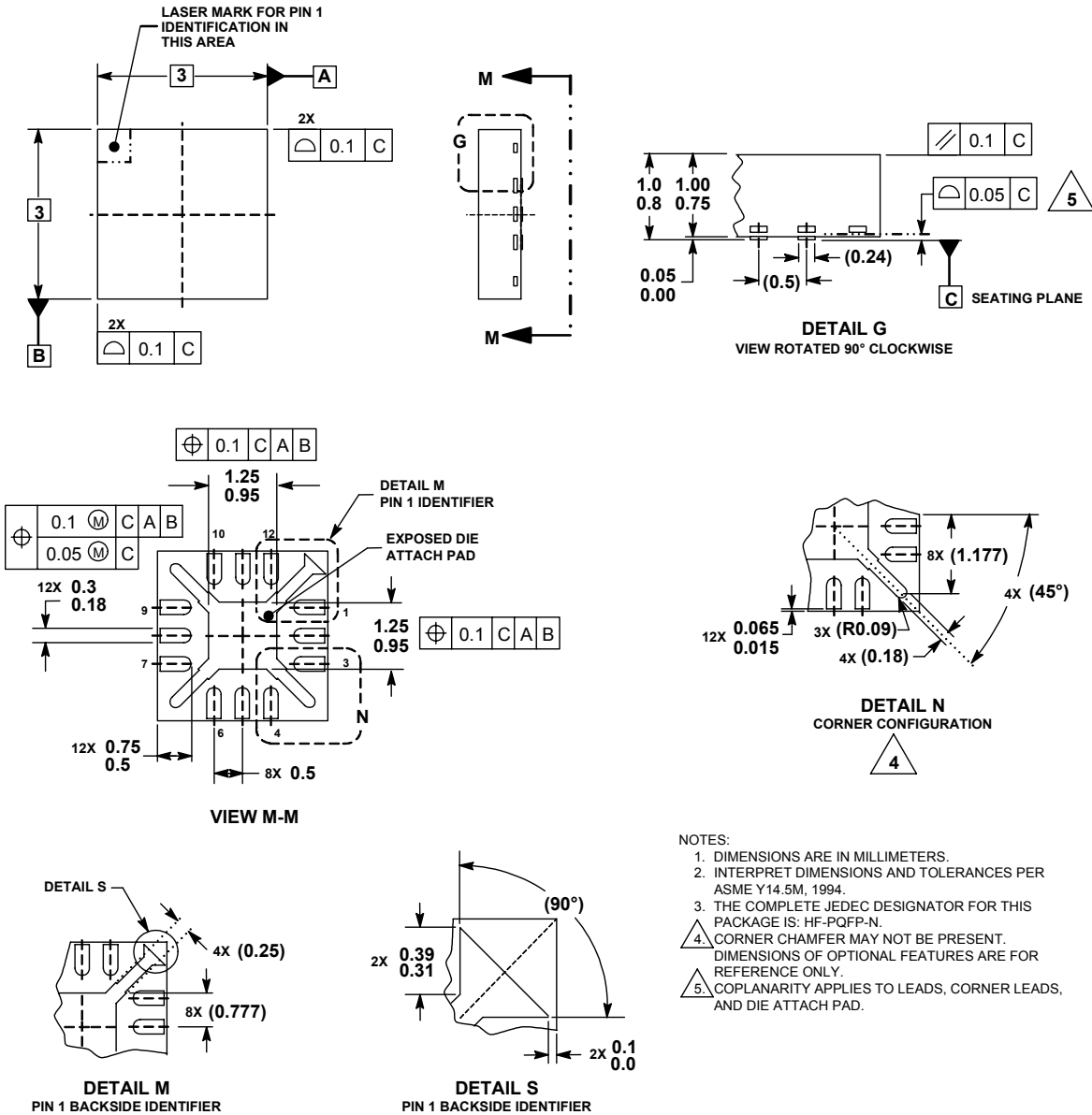

Figure 3. Application PCB (Not to Scale)

# 5 Packaging Information



**Figure 4. Outline Dimensions for QFN-12**  
(Case 1345-01, Issue A)

## **How to Reach Us:**

### **Home Page:**

[www.freescale.com](http://www.freescale.com)

### **E-mail:**

[support@freescale.com](mailto:support@freescale.com)

### **USA/Europe or Locations Not Listed:**

Freescale Semiconductor  
Technical Information Center, CH370  
1300 N. Alma School Road  
Chandler, Arizona 85224  
+1-800-521-6274 or +1-480-768-2130  
[support@freescale.com](mailto:support@freescale.com)

### **Europe, Middle East, and Africa:**

Freescale Halbleiter Deutschland GmbH  
Technical Information Center  
Schatzbogen 7  
81829 Muenchen, Germany  
+44 1296 380 456 (English)  
+46 8 52200080 (English)  
+49 89 92103 559 (German)  
+33 1 69 35 48 48 (French)  
[support@freescale.com](mailto:support@freescale.com)

### **Japan:**

Freescale Semiconductor Japan Ltd.  
Headquarters  
ARCO Tower 15F  
1-8-1, Shimo-Meguro, Meguro-ku,  
Tokyo 153-0064  
Japan  
0120 191014 or +81 3 5437 9125  
[support.japan@freescale.com](mailto:support.japan@freescale.com)

### **Asia/Pacific:**

Freescale Semiconductor Hong Kong Ltd.  
Technical Information Center  
2 Dai King Street  
Tai Po Industrial Estate  
Tai Po, N.T., Hong Kong  
+800 2666 8080  
[support.asia@freescale.com](mailto:support.asia@freescale.com)

### **For Literature Requests Only:**

Freescale Semiconductor Literature Distribution Center  
P.O. Box 5405  
Denver, Colorado 80217  
1-800-441-2447 or 303-675-2140  
Fax: 303-675-2150  
[LDCForFreescaleSemiconductor@hibbertgroup.com](mailto:LDCForFreescaleSemiconductor@hibbertgroup.com)

RoHS-compliant and/or Pb- free versions of Freescale products have the functionality and electrical characteristics of their non-RoHS-compliant and/or non-Pb- free counterparts. For further information, see <http://www.freescale.com> or contact your Freescale sales representative.

For information on Freescale's Environmental Products program, go to <http://www.freescale.com/epp>.

Information in this document is provided solely to enable system and software implementers to use Freescale Semiconductor products. There are no express or implied copyright licenses granted hereunder to design or fabricate any integrated circuits or integrated circuits based on the information in this document.

Freescale Semiconductor reserves the right to make changes without further notice to any products herein. Freescale Semiconductor makes no warranty, representation or guarantee regarding the suitability of its products for any particular purpose, nor does Freescale Semiconductor assume any liability arising out of the application or use of any product or circuit, and specifically disclaims any and all liability, including without limitation consequential or incidental damages. "Typical" parameters that may be provided in Freescale Semiconductor data sheets and/or specifications can and do vary in different applications and actual performance may vary over time. All operating parameters, including "Typicals", must be validated for each customer application by customer's technical experts. Freescale Semiconductor does not convey any license under its patent rights nor the rights of others. Freescale Semiconductor products are not designed, intended, or authorized for use as components in systems intended for surgical implant into the body, or other applications intended to support or sustain life, or for any other application in which the failure of the Freescale Semiconductor product could create a situation where personal injury or death may occur. Should Buyer purchase or use Freescale Semiconductor products for any such unintended or unauthorized application, Buyer shall indemnify and hold Freescale Semiconductor and its officers, employees, subsidiaries, affiliates, and distributors harmless against all claims, costs, damages, and expenses, and reasonable attorney fees arising out of, directly or indirectly, any claim of personal injury or death associated with such unintended or unauthorized use, even if such claim alleges that Freescale Semiconductor was negligent regarding the design or manufacture of the part.

Freescale™ and the Freescale logo are trademarks of Freescale Semiconductor, Inc. All other product or service names are the property of their respective owners.

© Freescale Semiconductor, Inc., 2003, 2005. All rights reserved.