



ARCHIVED BY FREESCALE SEMICONDUCTOR, INC. 2005

# Wideband FM IF

The MC13155 is a complete wideband FM detector designed for satellite TV and other wideband data and analog FM applications. This device may be cascaded for higher IF gain and extended Receive Signal Strength Indicator (RSSI) range.

- 12 MHz Video/Baseband Demodulator
- Ideal for Wideband Data and Analog FM Systems
- Limiter Output for Cascade Operation
- Low Drain Current: 7.0 mA
- Low Supply Voltage: 3.0 to 6.0 V
- Operates to 300 MHz

## MC13155

### WIDEBAND FM IF

#### SEMICONDUCTOR TECHNICAL DATA

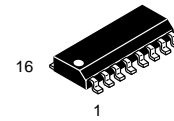

**D SUFFIX**  
PLASTIC PACKAGE  
CASE 751B  
(SO-16)

#### MAXIMUM RATINGS

Rating	Pin	Symbol	Value	Unit
Power Supply Voltage	11, 14	$V_{EE}$ (max)	6.5	Vdc
Input Voltage	1, 16	$V_{in}$	1.0	Vrms
Junction Temperature	—	$T_J$	+150	°C
Storage Temperature Range	—	$T_{stg}$	-65 to +150	°C

**NOTE:** Devices should not be operated at or outside these values. The "Recommended Operating Conditions" provide for actual device operation.

**Figure 1. Representative Block Diagram**

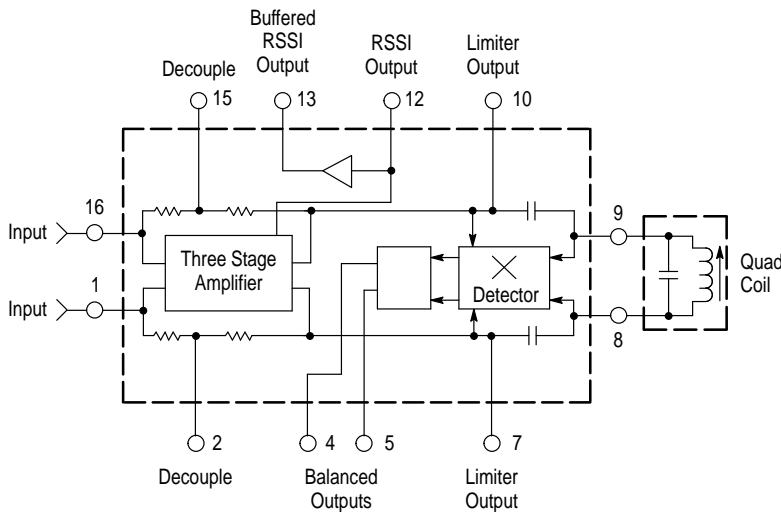

**NOTE:** This device requires careful layout and decoupling to ensure stable operation.

#### PIN CONNECTIONS

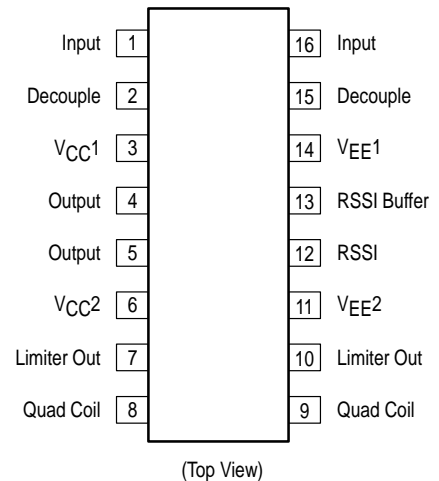

#### ORDERING INFORMATION

Device	Operating Temperature Range	Package
MC13155D	$T_A = -40$ to $+85^\circ\text{C}$	SO-16

Freescale Semiconductor, Inc. ARCHIVED BY FREESCALE SEMICONDUCTOR, INC. 2005

ARCHIVE INFORMATION

# Freescale Semiconductor, Inc.

## RECOMMENDED OPERATING CONDITIONS

Rating	Pin	Symbol	Value	Unit
Power Supply Voltage ( $T_A = 25^\circ\text{C}$ ) $-40^\circ\text{C} \leq T_A \leq 85^\circ\text{C}$	11, 14 3, 6	$V_{EE}$ $V_{CC}$	$-3.0$ to $-6.0$ Grounded	Vdc
Maximum Input Frequency	1, 16	$f_{in}$	300	MHz
Ambient Temperature Range	–	$T_J$	$-40$ to $+85$	$^\circ\text{C}$

## DC ELECTRICAL CHARACTERISTICS ( $T_A = 25^\circ\text{C}$ , no input signal.)

Characteristic	Pin	Symbol	Min	Typ	Max	Unit
Drain Current ( $V_{EE} = -5.0$ Vdc)	11	$I_{11}$	2.0	2.8	4.0	mA
( $V_{EE} = -5.0$ Vdc)	14	$I_{14}$	3.0	4.3	6.0	
( $V_{EE} = -5.0$ Vdc)	14	$I_{14}$	3.0	4.3	6.0	
Drain Current Total (see Figure 3) ( $V_{EE} = -5.0$ Vdc)	11, 14	$I_{Total}$	5.0	7.1	10	mA
( $V_{EE} = -6.0$ Vdc)			5.0	7.5	10.5	
( $V_{EE} = -3.0$ Vdc)			5.0	7.5	10.5	
			4.7	6.6	9.5	

## AC ELECTRICAL CHARACTERISTICS ( $T_A = 25^\circ\text{C}$ , $f_{IF} = 70$ MHz, $V_{EE} = -5.0$ Vdc Figure 2, unless otherwise noted.)

Characteristic	Pin	Min	Typ	Max	Unit
Input for $-3$ dB Limiting Sensitivity	1, 16	–	1.0	2.0	mVrms
Differential Detector Output Voltage ( $V_{in} = 10$ mVrms) ( $f_{dev} = \pm 3.0$ MHz) ( $V_{EE} = -6.0$ Vdc)	4, 5	470	590	700	mV <sub>p-p</sub>
( $V_{EE} = -5.0$ Vdc)		450	570	680	
( $V_{EE} = -3.0$ Vdc)		380	500	620	
Detector DC Offset Voltage	4, 5	$-250$	–	250	mVdc
RSSI Slope	13	1.4	2.1	2.8	$\mu\text{A}/\text{dB}$
RSSI Dynamic Range	13	31	35	39	dB
RSSI Output ( $V_{in} = 100$ $\mu\text{Vrms}$ )	12	–	2.1	–	$\mu\text{A}$
( $V_{in} = 1.0$ mVrms)		–	2.4	–	
( $V_{in} = 10$ mVrms)		16	24	36	
( $V_{in} = 100$ mVrms)		–	65	–	
( $V_{in} = 500$ mVrms)		–	75	–	
RSSI Buffer Maximum Output Current ( $V_{in} = 10$ mVrms)	13	–	2.3	–	mAdc
Differential Limiter Output ( $V_{in} = 1.0$ mVrms)	7, 10	100	140	–	mVrms
( $V_{in} = 10$ mVrms)		–	180	–	
Demodulator Video 3.0 dB Bandwidth	4, 5	–	12	–	MHz
Input Impedance (Figure 14) @ 70 MHz $R_p$ ( $V_{EE} = -5.0$ Vdc)	1, 16	–	450	–	$\Omega$
$C_p$ ( $C_2=C_{15} = 100$ p)		–	4.8	–	pF
Differential IF Power Gain	1, 7, 10, 16	–	46	–	dB

**NOTE:** Positive currents are out of the pins of the device.

# Freescale Semiconductor, Inc.

## CIRCUIT DESCRIPTION

The MC13155 consists of a wideband three-stage limiting amplifier, a wideband quadrature detector which may be operated up to 200 MHz, and a received signal strength indicator (RSSI) circuit which provides a current output linearly proportional to the IF input signal level for approximately 35 dB range of input level.

Figure 2. Test Circuit

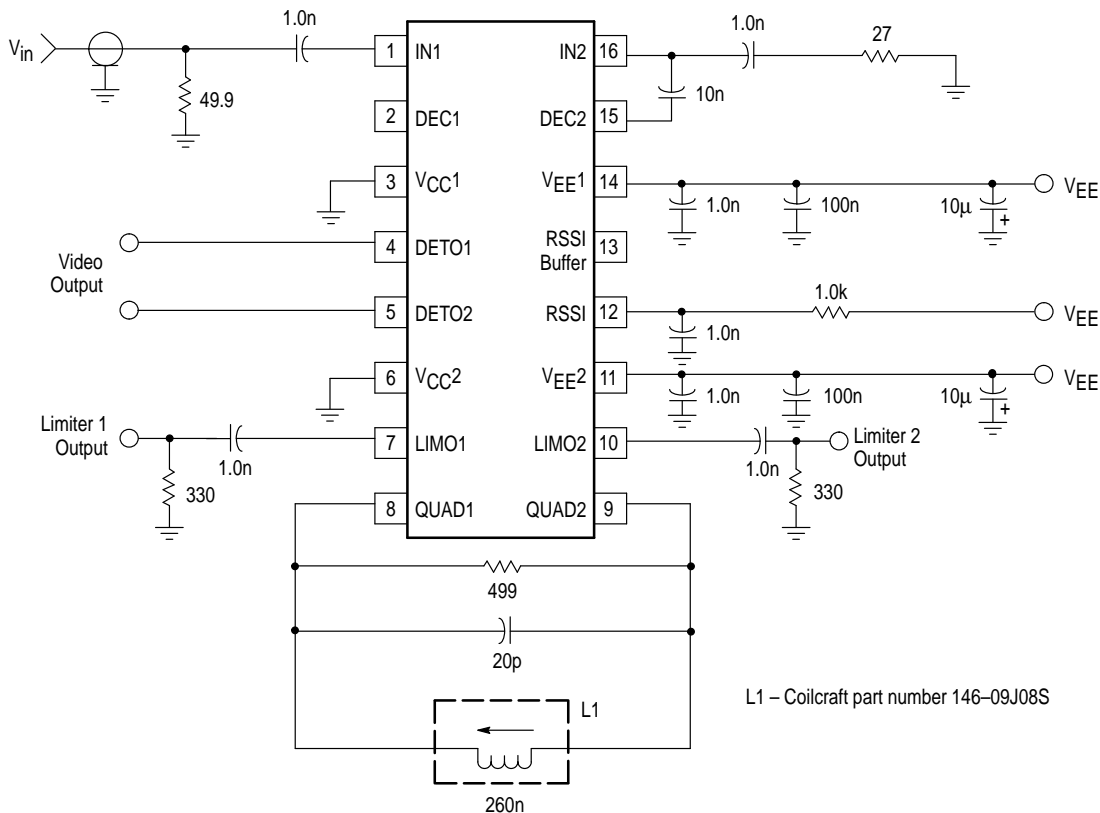

## APPLICATIONS INFORMATION

### Evaluation PC Board

The evaluation PCB shown in Figures 19 and 20 is very versatile and is designed to cascade two ICs. The center section of the board provides an area for attaching all surface mount components to the circuit side and radial leaded components to the component ground side of the PCB (see Figures 17 and 18). Additionally, the peripheral area surrounding the RF core provides pads to add supporting and interface circuitry as a particular application dictates. This evaluation board will be discussed and referenced in this section.

### Limiting Amplifier

Differential input and output ports interfacing the three stage limiting amplifier provide a differential power gain of typically 46 dB and useable frequency range of 300 MHz. The IF gain flatness may be controlled by decoupling of the internal feedback network at Pins 2 and 15.

Scattering parameter (S-parameter) characterization of the IF as a two port linear amplifier is useful to implement maximum stable power gain, input matching, and stability over a desired bandpass response and to ensure stable operation outside the bandpass as well. The MC13155 is unconditionally stable over most of its useful operating frequency range; however, it can be made unconditionally stable over its entire operating range with the proper decoupling of Pins 2 and 15. Relatively small decoupling capacitors of about 100 pF have a significant effect on the wideband response and stability. This is shown in the scattering parameter tables where S-parameters are shown for various values of C2 and C15 and at  $V_{EE}$  of  $-3.0$  and  $-5.0$  Vdc.

## TYPICAL PERFORMANCE AT TEMPERATURE

(See Figure 2, Test Circuit)

ARCHIVED BY FREESCALE SEMICONDUCTOR, INC. 2005

Figure 3. Drain Current versus Supply Voltage

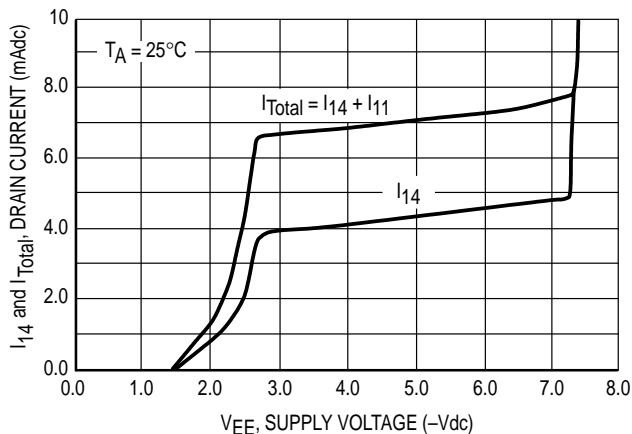

Figure 4. RSSI Output versus Frequency and Input Signal Level

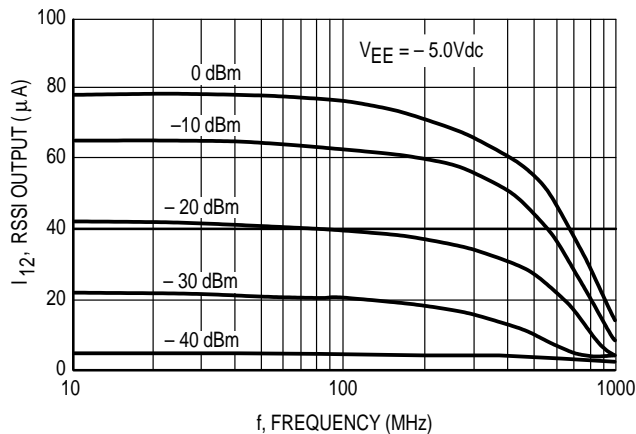

Figure 5. Total Drain Current versus Ambient Temperature and Supply Voltage

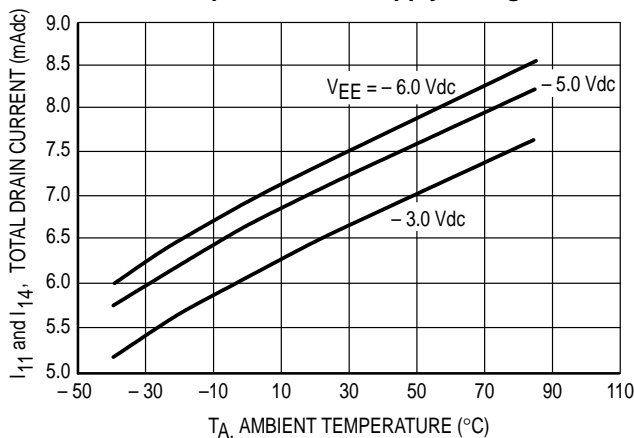

Figure 6. Detector Drain Current and Limiter Drain Current versus Ambient Temperature

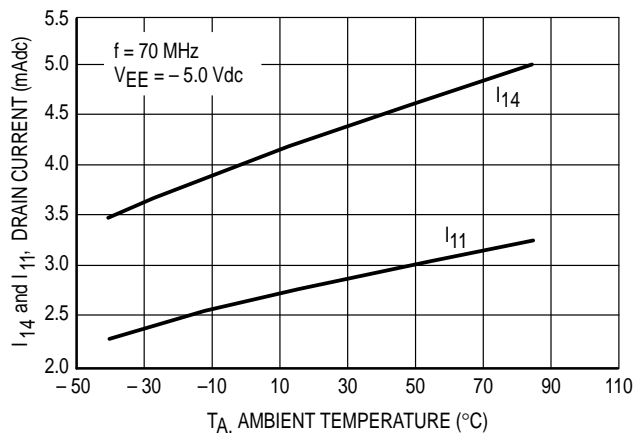

Figure 7. RSSI Output versus Ambient Temperature and Supply Voltage

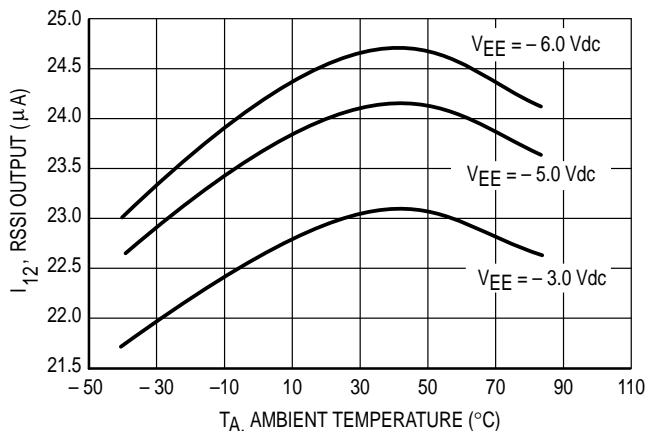

Figure 8. RSSI Output versus Input Signal Voltage (Vin at Temperature)

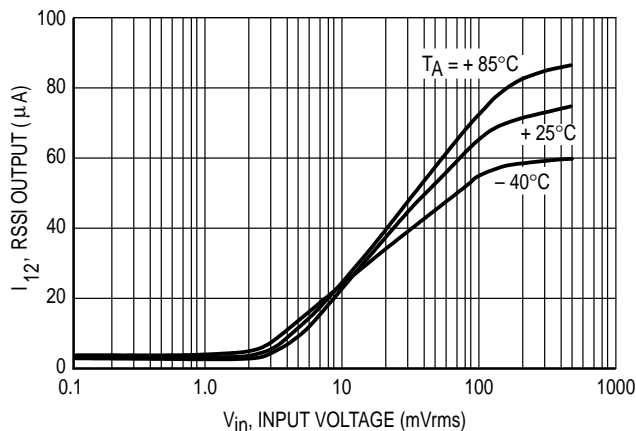

Figure 9. Differential Detector Output Voltage versus Ambient Temperature and Supply Voltage

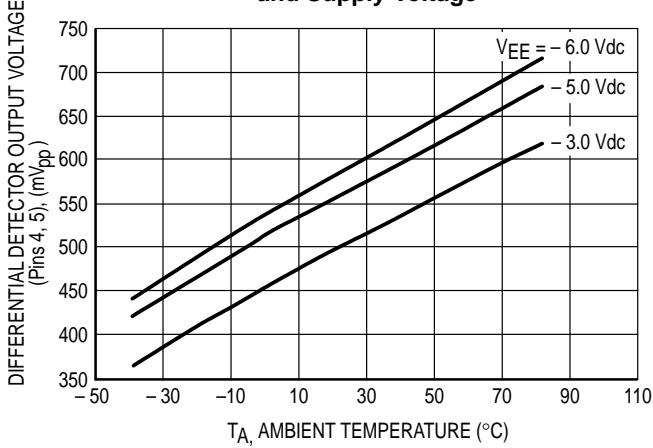

Figure 10. Differential Limiter Output Voltage versus Ambient Temperature ( $V_{in} = 1$  and 10 mVrms)

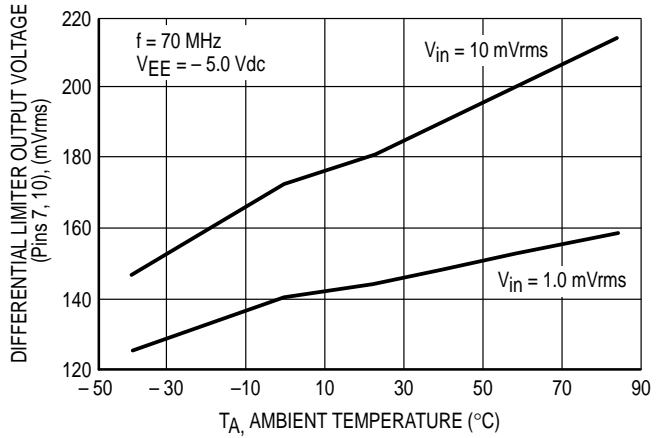

Figure 11A. Differential Detector Output Voltage versus Q of Quadrature LC Tank

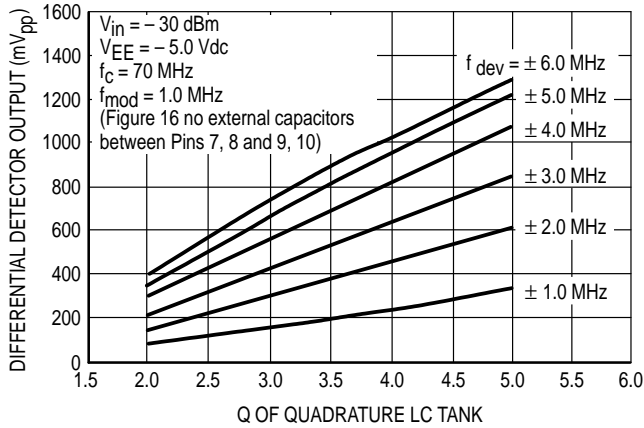

Figure 11B. Differential Detector Output Voltage versus Q of Quadrature LC Tank

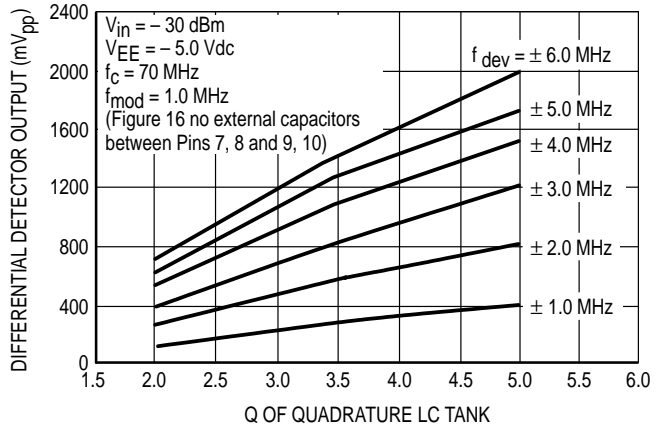

Figure 12. RSSI Output Voltage versus IF Input

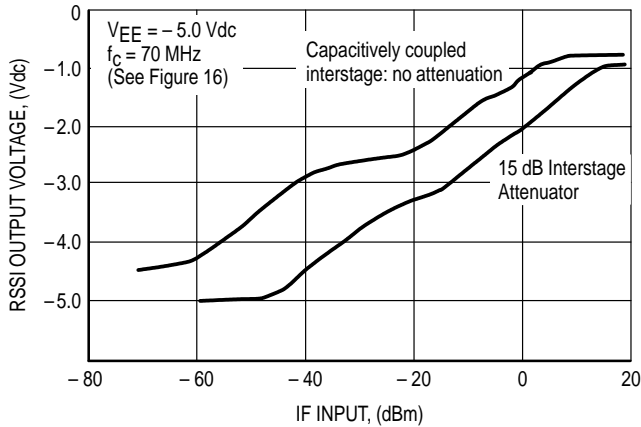
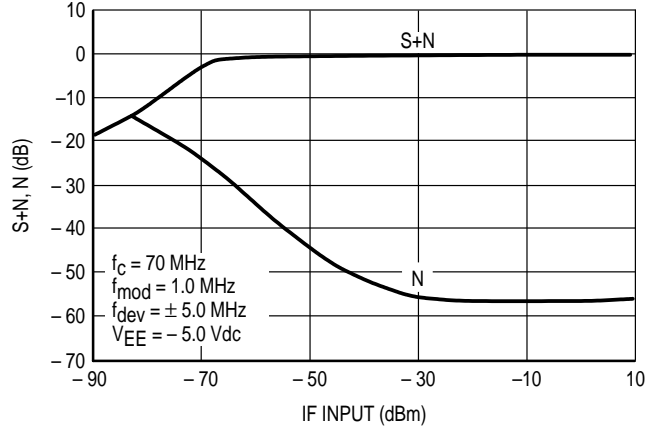

Figure 13. - S+N, N versus IF Input



# Freescale Semiconductor, Inc.

In the S-parameters measurements, the IF is treated as a two-port linear class A amplifier. The IF amplifier is measured with a single-ended input and output configuration in which the Pins 16 and 7 are terminated in the series combination of a 47 Ω resistor and a 10 nF capacitor to V<sub>CC</sub> ground (see Figure 14. S-Parameter Test Circuit).

The S-parameters are in polar form as the magnitude (MAG) and angle (ANG). Also listed in the tables are the calculated values for the stability factor (K) and the Maximum

Available Gain (MAG). These terms are related in the following equations:

$$K = (1 - |S_{11}|^2 - |S_{22}|^2 + |\Delta|^2) / (2 |S_{12} S_{21}|)$$

where:  $|\Delta| = |S_{11} S_{22} - S_{12} S_{21}|$ .

$$MAG = 10 \log |S_{21}| / |S_{12}| + 10 \log |K - (K^2 - 1)^{1/2}|$$

where:  $K > 1$ . The necessary and sufficient conditions for unconditional stability are given as  $K > 1$ :

$$B1 = 1 + |S_{11}|^2 - |S_{22}|^2 - |\Delta|^2 > 0$$

Figure 14. S-Parameter Test Circuit

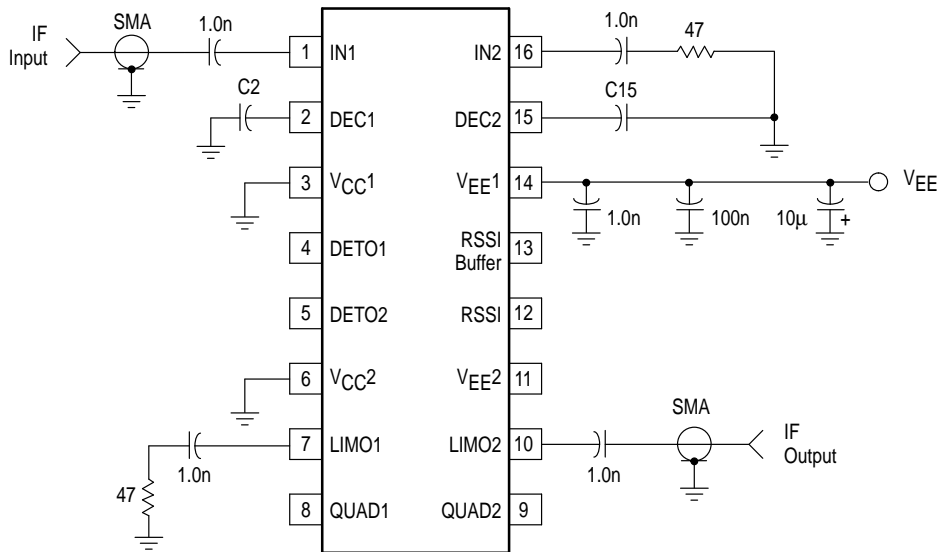

# Freescale Semiconductor, Inc.

**S-Parameters** ( $V_{EE} = -5.0$  Vdc,  $T_A = 25^\circ\text{C}$ ,  $C_2$  and  $C_{15} = 0$  pF)

Frequency MHz	Input S11		Forward S21		Rev S12		Output S22		K	MAG
	MAG	ANG	MAG	ANG	MAG	ANG	MAG	ANG	MAG	dB
1.0	0.94	-13	8.2	143	0.001	7.0	0.87	-22	2.2	32
2.0	0.78	-23	23.5	109	0.001	-40	0.64	-31	4.2	33.5
5.0	0.48	1.0	39.2	51	0.001	-97	0.34	-17	8.7	33.7
7.0	0.59	15	40.3	34	0.001	-41	0.33	-13	10.6	34.6
10	0.75	17	40.9	19	0.001	-82	0.41	-1.0	5.7	36.7
20	0.95	7.0	42.9	-6.0	0.001	-42	0.45	0	1.05	46.4
50	0.98	-10	42.2	-48	0.001	-9.0	0.52	-3.0	0.29	-
70	0.95	-16	39.8	-68	0.001	112	0.54	-16	1.05	46.4
100	0.93	-23	44.2	-93	0.001	80	0.53	-22	0.76	-
150	0.91	-34	39.5	-139	0.001	106	0.50	-34	0.94	-
200	0.87	-47	34.9	-179	0.002	77	0.42	-44	0.97	-
500	0.89	-103	11.1	-58	0.022	57	0.40	-117	0.75	-
700	0.61	-156	3.5	-164	0.03	0	0.52	179	2.6	13.7
900	0.56	162	1.2	92	0.048	-44	0.47	112	4.7	4.5
1000	0.54	131	0.8	42	0.072	-48	0.44	76	5.1	0.4

**S-Parameters** ( $V_{EE} = -5.0$  Vdc,  $T_A = 25^\circ\text{C}$ ,  $C_2$  and  $C_{15} = 100$  pF)

Frequency MHz	Input S11		Forward S21		Rev S12		Output S22		K	MAG
	MAG	ANG	MAG	ANG	MAG	ANG	MAG	ANG	MAG	dB
1.0	0.98	-15	11.7	174	0.001	-14	0.84	-27	1.2	37.4
2.0	0.50	-2.0	39.2	85.5	0.001	-108	0.62	-35	6.0	35.5
5.0	0.87	8.0	39.9	19	0.001	100	0.47	-9.0	4.2	39.2
7.0	0.90	5.0	40.4	9.0	0.001	-40	0.45	-8.0	3.1	40.3
10	0.92	3.0	41	1.0	0.001	-40	0.44	-5.0	2.4	41.8
20	0.92	-2.0	42.4	-14	0.001	-87	0.49	-6.0	2.4	41.9
50	0.91	-8.0	41.2	-45	0.001	85	0.50	-5.0	2.3	42
70	0.91	-11	39.1	-63	0.001	76	0.52	-4.0	2.2	41.6
100	0.91	-15	43.4	-84	0.001	85	0.50	-11	1.3	43.6
150	0.90	-22	38.2	-126	0.001	96	0.43	-22	1.4	41.8
200	0.86	-33	35.5	-160	0.002	78	0.43	-21	1.3	39.4
500	0.80	-66	8.3	-9.0	0.012	75	0.57	-63	1.7	23.5
700	0.62	-96	2.9	-95	0.013	50	0.49	-111	6.3	12.5
900	0.56	-120	1.0	-171	0.020	53	0.44	-150	13.3	2.8
1000	0.54	-136	0.69	154	0.034	65	0.44	-179	12.5	-0.8

Freescale Semiconductor, Inc. ARCHIVED BY FREESCALE SEMICONDUCTOR, INC. 2005

ARCHIVE INFORMATION

# Freescale Semiconductor, Inc.

**S-Parameters** ( $V_{EE} = -5.0$  Vdc,  $T_A = 25^\circ\text{C}$ ,  $C_2$  and  $C_{15} = 680$  pF)

Frequency MHz	Input S11		Forward S21		Rev S12		Output S22		K	MAG
	MAG	ANG	MAG	ANG	MAG	ANG	MAG	ANG	MAG	dB
1.0	0.74	4.0	53.6	110	0.001	101	0.97	-35	0.58	-
2.0	0.90	3.0	70.8	55	0.001	60	0.68	-34	1.4	45.6
5.0	0.91	0	87.1	21	0.001	-121	0.33	-60	1.1	49
7.0	0.91	0	90.3	11	0.001	-18	0.25	-67	1.2	48.4
10	0.91	-2.0	92.4	2.0	0.001	33	0.14	-67	1.5	47.5
20	0.91	-4.0	95.5	-16	0.001	63	0.12	-15	1.3	48.2
50	0.90	-8.0	89.7	-50	0.001	-43	0.24	26	1.8	46.5
70	0.90	-10	82.6	-70	0.001	92	0.33	21	1.4	47.4
100	0.91	-14	77.12	-93	0.001	23	0.42	-1.0	1.05	49
150	0.94	-20	62.0	-122	0.001	96	0.42	-22	0.54	-
200	0.95	-33	56.9	-148	0.003	146	0.33	-62	0.75	-
500	0.82	-63	12.3	-12	0.007	79	0.44	-67	1.8	26.9
700	0.66	-98	3.8	-107	0.014	84	0.40	-115	4.8	14.6
900	0.56	-122	1.3	177	0.028	78	0.39	-166	8.0	4.7
1000	0.54	-139	0.87	141	0.048	76	0.41	165	7.4	0.96

**S-Parameters** ( $V_{EE} = -3.0$  Vdc,  $T_A = 25^\circ\text{C}$ ,  $C_2$  and  $C_{15} = 0$  pF)

Frequency MHz	Input S11		Forward S21		Rev S12		Output S22		K	MAG
	MAG	ANG	MAG	ANG	MAG	ANG	MAG	ANG	MAG	dB
1.0	0.89	-14	9.3	136	0.001	2.0	0.84	-27	3.2	30.7
2.0	0.76	-22	24.2	105	0.001	-90	0.67	-37	3.5	34.3
5.0	0.52	5.0	35.7	46	0.001	-32	0.40	-13	10.6	33.3
7.0	0.59	12	38.1	34	0.001	-41	0.40	-10	9.1	34.6
10	0.78	15	37.2	16	0.001	-92	0.40	-1.0	5.7	36.3
20	0.95	5.0	38.2	-9.0	0.001	47	0.51	-4.0	0.94	-
50	0.96	-11	39.1	-50	0.001	-103	0.48	-6.0	1.4	43.7
70	0.93	-17	36.8	-71	0.001	-76	0.52	-13	2.2	41.4
100	0.91	-25	34.7	-99	0.001	-152	0.51	-19	3.0	39.0
150	0.86	-37	33.8	-143	0.001	53	0.49	-34	1.7	39.1
200	0.81	-49	27.8	86	0.003	76	0.55	-56	2.4	35.1
500	0.70	-93	6.2	-41	0.015	93	0.40	-110	2.4	19.5
700	0.62	-144	1.9	-133	0.049	56	0.40	-150	3.0	8.25
900	0.39	-176	0.72	125	0.11	-18	0.25	163	5.1	-1.9
1000	0.44	166	0.49	80	0.10	-52	0.33	127	7.5	-4.8

Freescale Semiconductor, Inc.  
ARCHIVED BY FREESCALE SEMICONDUCTOR, INC. 2005

ARCHIVE INFORMATION

# Freescale Semiconductor, Inc.

**S-Parameters** ( $V_{EE} = -3.0$  Vdc,  $T_A = 25^\circ\text{C}$ ,  $C_2$  and  $C_{15} = 100$  pF)

Frequency MHz	Input S11		Forward S21		Rev S12		Output S22		K	MAG
	MAG	ANG	MAG	ANG	MAG	ANG	MAG	ANG	MAG	dB
1.0	0.97	-15	11.7	171	0.001	-4.0	0.84	-27	1.4	36.8
2.0	0.53	2.0	37.1	80	0.001	-91	0.57	-31	6.0	34.8
5.0	0.88	7.0	37.7	18	0.001	-9.0	0.48	-7.0	3.4	39.7
7.0	0.90	5.0	37.7	8.0	0.001	-11	0.49	-7.0	2.3	41
10	0.92	2.0	38.3	1.0	0.001	-59	0.51	-9.0	2.0	41.8
20	0.92	-2.0	39.6	-15	0.001	29	0.48	-3.0	1.9	42.5
50	0.91	-8.0	38.5	-46	0.001	-21	0.51	-7.0	2.3	41.4
70	0.91	-11	36.1	-64	0.001	49	0.50	-8.0	2.3	40.8
100	0.91	-15	39.6	-85	0.001	114	0.52	-13	1.7	37.8
150	0.89	-22	34.4	-128	0.001	120	0.48	-23	1.6	40.1
200	0.86	-33	32	-163	0.002	86	0.40	-26	1.7	37.8
500	0.78	-64	7.6	-12	0.013	94	0.46	-71	1.9	22.1
700	0.64	-98	2.3	-102	0.027	58	0.42	-109	4.1	10.1
900	0.54	-122	0.78	179	0.040	38.6	0.35	-147	10.0	-0.14
1000	0.53	-136	0.47	144	0.043	23	0.38	-171	15.4	-4.52

**S-Parameters** ( $V_{EE} = -3.0$  Vdc,  $T_A = 25^\circ\text{C}$ ,  $C_2$  and  $C_{15} = 680$  pF)

Frequency MHz	Input S11		Forward S21		Rev S12		Output S22		K	MAG
	MAG	ANG	MAG	ANG	MAG	ANG	MAG	ANG	MAG	dB
1.0	0.81	3.0	37	101	0.001	-19	0.90	-32	1.1	43.5
2.0	0.90	2.0	47.8	52.7	0.001	-82	0.66	-39	0.72	-
5.0	0.91	0	58.9	20	0.001	104	0.37	-56	2.3	44
7.0	0.90	-1	60.3	11	0.001	-76	0.26	-55	2.04	44
10	0.91	-2.0	61.8	3.0	0.001	105	0.18	-52	2.2	43.9
20	0.91	-4.0	63.8	-15	0.001	59	0.11	-13	2.0	44.1
50	0.90	-8.0	60.0	-48	0.001	96	0.22	33	2.3	43.7
70	0.90	-11	56.5	-67	0.001	113	0.29	15	2.3	43.2
100	0.91	-14	52.7	-91	0.001	177	0.36	5.0	2.0	43
150	0.93	-21	44.5	-126	0.001	155	0.35	-17	1.8	42.7
200	0.90	-43	41.2	-162	0.003	144	0.17	-31	1.6	34.1
500	0.79	-65	7.3	-13	0.008	80	0.44	-75	3.0	22
700	0.65	-97	2.3	-107	0.016	86	0.38	-124	7.1	10.2
900	0.56	-122	0.80	174	0.031	73	0.38	-174	12	0.37
1000	0.55	-139	0.52	137	0.50	71	0.41	157	11.3	-3.4

Freescale Semiconductor, Inc. ARCHIVED BY FREESCALE SEMICONDUCTOR, INC. 2005

ARCHIVE INFORMATION

## DC Biasing Considerations

The DC biasing scheme utilizes two  $V_{CC}$  connections (Pins 3 and 6) and two  $V_{EE}$  connections (Pins 14 and 10).  $V_{EE1}$  (Pin 14) is connected internally to the IF and RSSI circuits' negative supply bus while  $V_{EE2}$  (Pin 11) is connected internally to the quadrature detector's negative bus. Under positive ground operation, this unique configuration offers the ability to bias the RSSI and IF separately from the quadrature detector. When two ICs are cascaded as shown in the 70 MHz application circuit and provided by the PCB (see Figures 17 and 18), the first MC13155 is used without biasing its quadrature detector, thereby saving approximately 3.0 mA. A total current of 7.0 mA is used to fully bias each IC, thus the total current in the application circuit is approximately 11 mA. Both  $V_{CC}$  pins are biased by the same supply.  $V_{CC1}$  (Pin 3) is connected internally to the positive bus of the first half of the IF limiting amplifier, while  $V_{CC2}$  is internally connected to the positive bus of the RSSI, the quadrature detector circuit, and the second half of the IF limiting amplifier (see Figure 15). This distribution of the  $V_{CC}$  enhances the stability of the IC.

## RSSI Circuitry

The RSSI circuitry provides typically 35 dB of linear dynamic range and its output voltage swing is adjusted by

selection of the resistor from Pin 12 to  $V_{EE}$ . The RSSI slope is typically  $2.1 \mu\text{A}/\text{dB}$ ; thus, for a dynamic range of 35 dB, the current output is approximately  $74 \mu\text{A}$ . A 47 k resistor will yield an RSSI output voltage swing of 3.5 Vdc. The RSSI buffer output at Pin 13 is an emitter-follower and needs an external emitter resistor of 10 k to  $V_{EE}$ .

In a cascaded configuration (see circuit application in Figure 16), only one of the RSSI Buffer outputs (Pin 13) is used; the RSSI outputs (Pin 12 of each IC) are tied together and the one closest to the  $V_{EE}$  supply trace is decoupled to  $V_{CC}$  ground. The two pins are connected to  $V_{EE}$  through a 47 k resistor. This resistor sources a RSSI current which is proportional to the signal level at the IF input; typically,  $1.0 \text{ mVrms}$  ( $-47 \text{ dBm}$ ) is required to place the MC13155 into limiting. The measured RSSI output voltage response of the application circuit is shown in Figure 12. Since the RSSI current output is dependent upon the input signal level at the IF input, a careful accounting of filter losses, matching and other losses and gains must be made in the entire receiver system. In the block diagram of the application circuit shown below, an accounting of the signal levels at points throughout the system shows how the RSSI response in Figure 12 is justified.

Block Diagram of 70 MHz Video Receiver Application Circuit

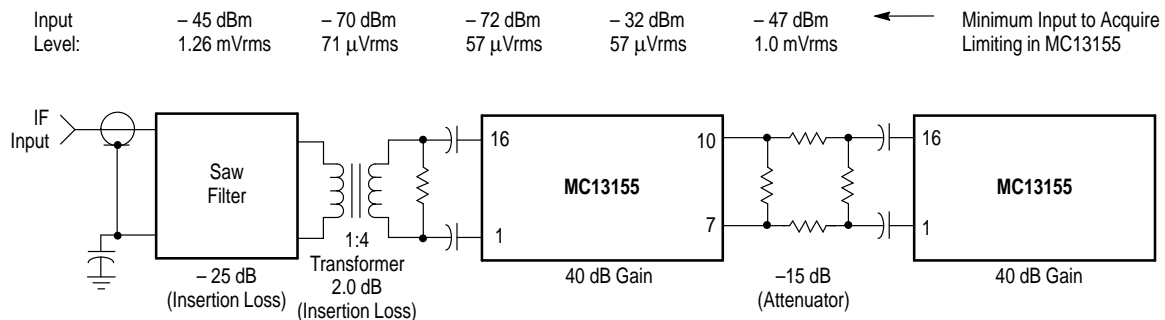

## Cascading Stages

The limiting IF output is pinned-out differentially, cascading is easily achieved by AC coupling stage to stage. In the evaluation PCB, AC coupling is shown, however, interstage filtering may be desirable in some applications. In which case, the S-parameters provide a means to implement a low loss interstage match and better receiver sensitivity.

Where a linear response of the RSSI output is desired when cascading the ICs, it is necessary to provide at least 10 dB of interstage loss. Figure 12 shows the RSSI response with and without interstage loss. A 15 dB resistive attenuator is an inexpensive way to linearize the RSSI response. This has its drawbacks since it is a wideband noise source that is dependent upon the source and load impedance and the amount of attenuation that it provides. A better, although more costly, solution would be a bandpass filter designed to the desired center frequency and bandpass response while carefully selecting the insertion loss. A network topology

shown below may be used to provide a bandpass response with the desired insertion loss.

Network Topology

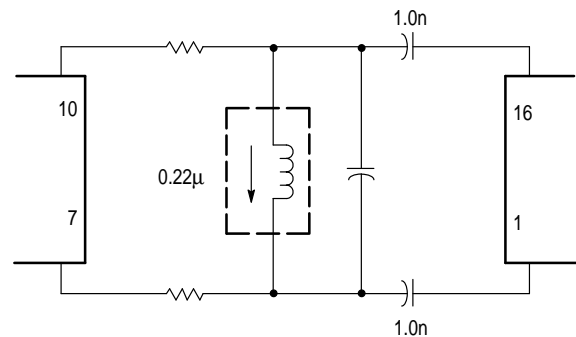

## Quadrature Detector

The quadrature detector is coupled to the IF with internal 2.0 pF capacitors between Pins 7 and 8 and Pins 9 and 10. For wideband data applications, such as FM video and satellite receivers, the drive to the detector can be increased with additional external capacitors between these pins, thus, the recovered video signal level output is increased for a given bandwidth (see Figure 11A and Figure 11B).

The wideband performance of the detector is controlled by the loaded Q of the LC tank circuit. The following equation defines the components which set the detector circuit's bandwidth:

$$Q = R_T / X_L \quad (1)$$

where:  $R_T$  is the equivalent shunt resistance across the LC Tank and  $X_L$  is the reactance of the quadrature inductor at the IF frequency ( $X_L = 2\pi fL$ ).

The inductor and capacitor are chosen to form a resonant LC Tank with the PCB and parasitic device capacitance at the desired IF center frequency as predicted by:

$$f_c = (2\pi \sqrt{LC_p})^{-1} \quad (2)$$

where: L is the parallel tank inductor and  $C_p$  is the equivalent parallel capacitance of the parallel resonant tank circuit.

The following is a design example for a wideband detector at 70 MHz and a loaded Q of 5. The loaded Q of the quadrature detector is chosen somewhat less than the Q of the IF bandpass. For an IF frequency of 70 MHz and an IF bandpass of 10.9 MHz, the IF bandpass Q is approximately 6.4.

Example:

Let the external  $C_{ext} = 20$  pF. (The minimum value here should be greater than 15 pF making it greater than the internal device and PCB parasitic capacitance,  $C_{int} \approx 3.0$  pF).

$$C_p = C_{int} + C_{ext} = 23 \text{ pF}$$

Rewrite Equation 2 and solve for L:

$$L = (0.159)^2 / (C_p f_c^2)$$

$L = 198$  nH, thus, a standard value is chosen.

$L = 0.22$   $\mu$ H (tunable shielded inductor).

The value of the total damping resistor to obtain the required loaded Q of 5 can be calculated by rearranging Equation 1:

$$R_T = Q(2\pi fL)$$

$$R_T = 5 (2\pi)(70)(0.22) = 483.8 \Omega.$$

The internal resistance,  $R_{int}$  between the quadrature tank Pins 8 and 9 is approximately 3200  $\Omega$  and is considered in determining the external resistance,  $R_{ext}$  which is calculated from:

$$R_{ext} = ((R_T)(R_{int})) / (R_{int} - R_T)$$

$R_{ext} = 570$ , thus, choose the standard value.

$R_{ext} = 560 \Omega$ .

## SAW Filter

In wideband video data applications, the IF occupied bandwidth may be several MHz wide. A good rule of thumb is to choose the IF frequency about 10 or more times greater than the IF occupied bandwidth. The IF bandpass filter is a SAW filter in video data applications where a very selective response is needed (i.e., very sharp bandpass response). The evaluation PCB is laid out to accommodate two SAW filter package types: 1) A five-leaded plastic SIP package. Recommended part numbers are Siemens X6950M which operates at 70 MHz; 10.4 MHz 3 dB passband, X6951M (X252.8) which operates at 70 MHz; 9.2 MHz 3 dB passband; and X6958M which operates at 70 MHz, 6.3 MHz 3 dB passband, and 2) A four-leaded TO-39 metal can package. Typical insertion loss in a wide bandpass SAW filter is 25 dB.

The above SAW filters require source and load impedances of 50  $\Omega$  to assure stable operation. On the PC board layout, space is provided to add a matching network, such as a 1:4 surface mount transformer between the SAW filter output and the input to the MC13155. A 1:4 transformer, made by Coilcraft and Mini Circuits, provides a suitable interface (see Figures 16, 17 and 18). In the circuit and layout, the SAW filter and the MC13155 are differentially configured with interconnect traces which are equal in length and symmetrical. This balanced feed enhances RF stability, phase linearity, and noise performance.

Freescale Semiconductor, Inc. ARCHIVED BY FREESCALE SEMICONDUCTOR, INC. 2005

ARCHIVE INFORMATION

Figure 15. Simplified Internal Circuit Schematic

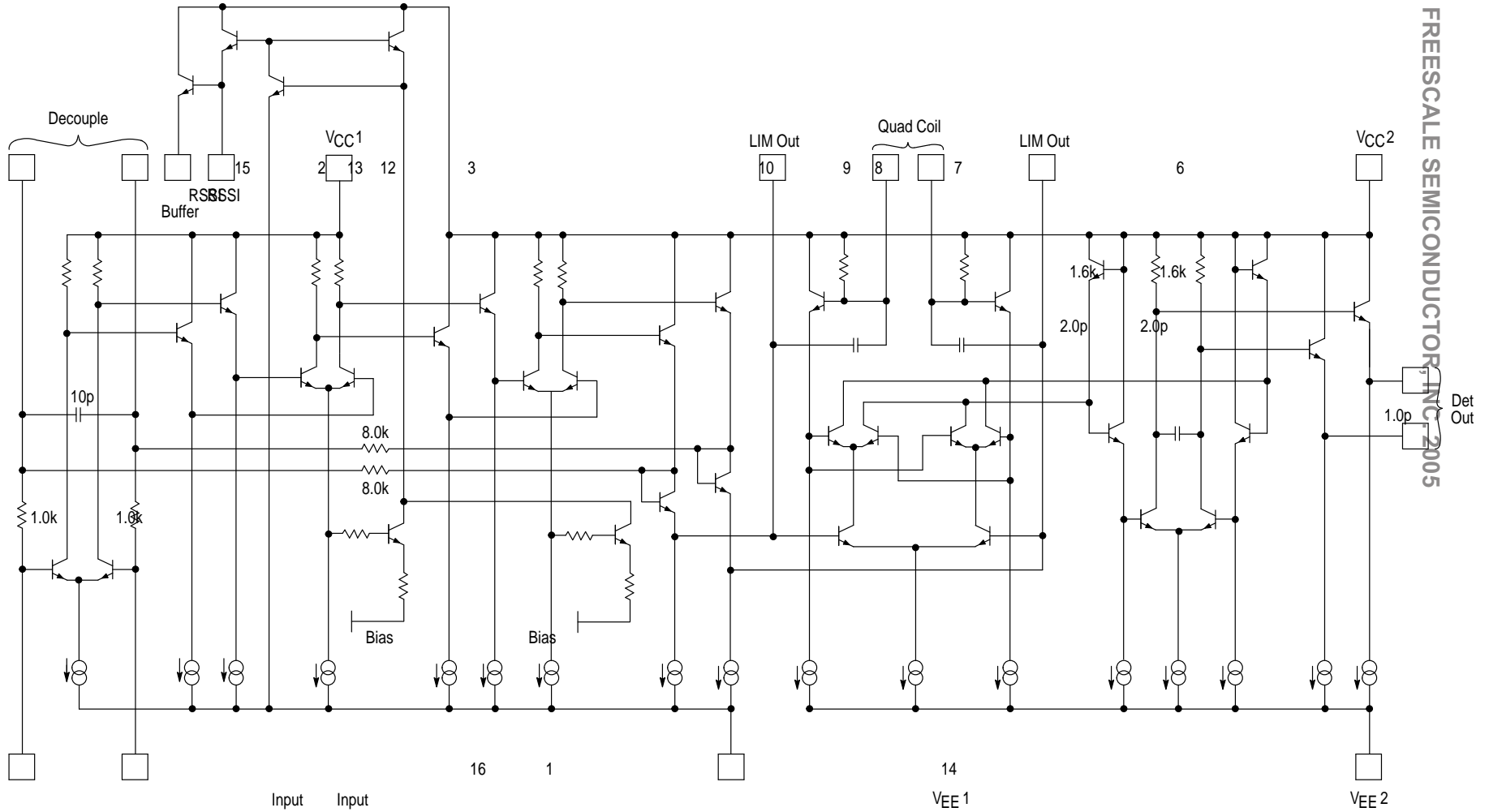

ARCHIVED BY FREESCALE SEMICONDUCTOR, INC. 2005

Freescale Semiconductor, Inc.

# Freescale Semiconductor, Inc.

Figure 16. 70 MHz Video Receiver Application Circuit

ARCHIVED BY FREESCALE SEMICONDUCTOR, INC. 2005

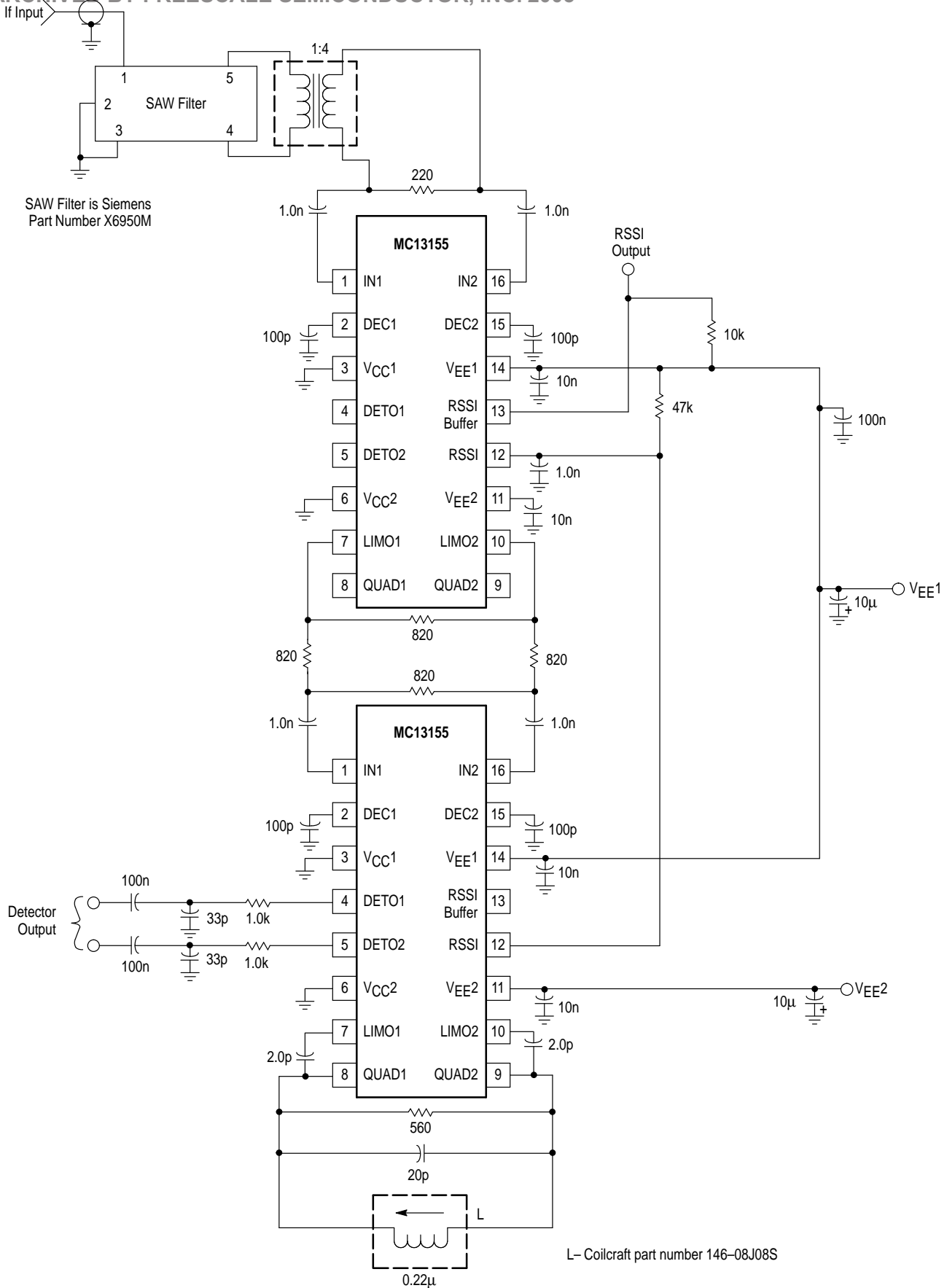

Freescale Semiconductor, Inc. ARCHIVED BY FREESCALE SEMICONDUCTOR, INC. 2005

ARCHIVE INFORMATION



Figure 19. Circuit Side View

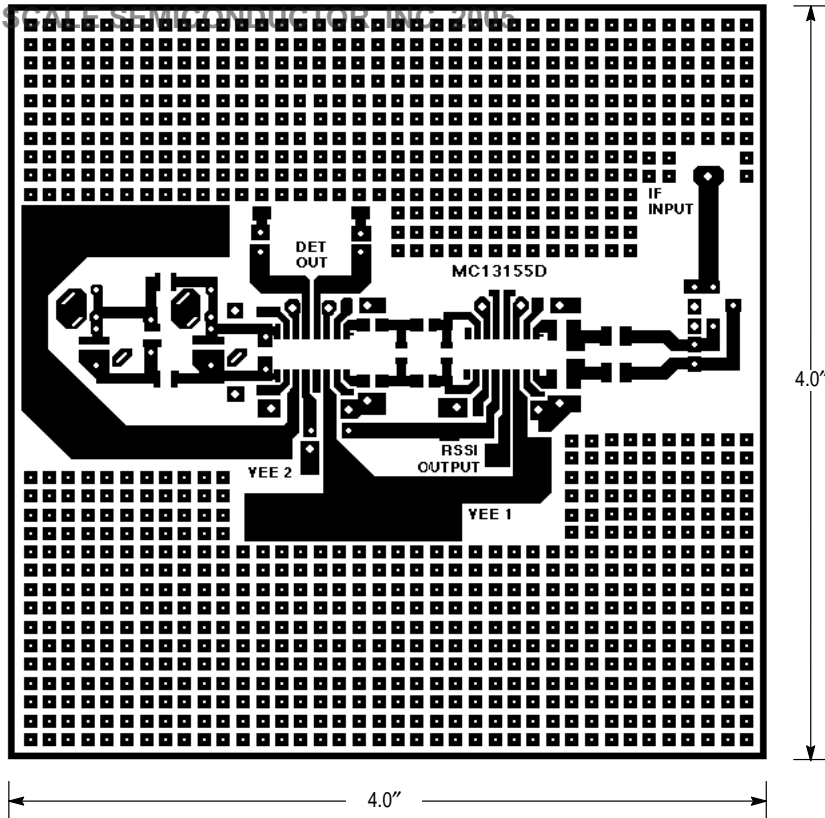
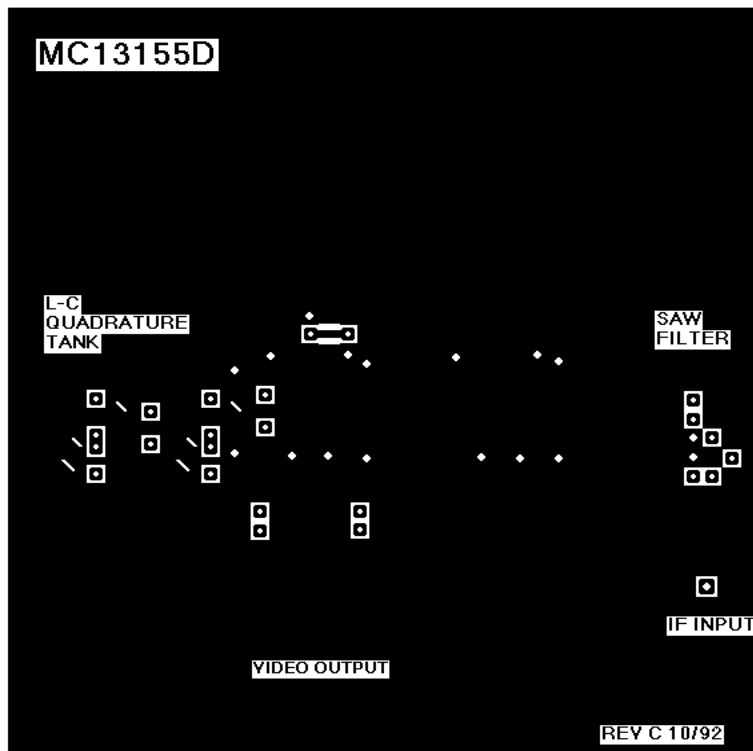

Figure 20. Ground Side View



# Freescale Semiconductor, Inc.

## OUTLINE DIMENSIONS

ARCHIVED BY FREESCALE SEMICONDUCTOR, INC. 2005

D SUFFIX  
PLASTIC PACKAGE  
CASE 751B  
(SO-16)

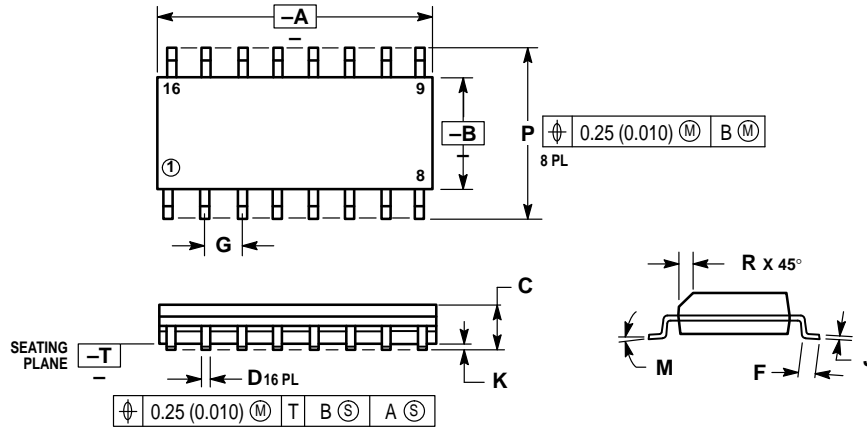

### NOTES:

1. DIMENSIONING AND TOLERANCING PER ANSI Y14.5M, 1982.
2. CONTROLLING DIMENSION: MILLIMETER.
3. DIMENSION A AND B DO NOT INCLUDE MOLD PROTRUSION.
4. MAXIMUM MOLD PROTRUSION 0.15 (0.006) PER SIDE.
5. 751B-03 IS OBSOLETE, NEW STANDARD 751B-04.

DIM	MILLIMETERS		INCHES	
	MIN	MAX	MIN	MAX
A	9.80	10.00	0.386	0.393
B	3.80	4.00	0.150	0.157
C	1.35	1.75	0.054	0.068
D	0.35	0.49	0.014	0.019
F	0.40	1.25	0.016	0.049
G	1.27 BSC		0.050 BSC	
J	0.19	0.25	0.008	0.009
K	0.10	0.25	0.004	0.009
M	0°	7°	0°	7°
P	5.80	6.20	0.229	0.244
R	0.25	0.50	0.010	0.019

Motorola reserves the right to make changes without further notice to any products herein. Motorola makes no warranty, representation or guarantee regarding the suitability of its products for any particular purpose, nor does Motorola assume any liability arising out of the application or use of any product or circuit, and specifically disclaims any and all liability, including without limitation consequential or incidental damages. "Typical" parameters which may be provided in Motorola data sheets and/or specifications can and do vary in different applications and actual performance may vary over time. All operating parameters, including "Typicals" must be validated for each customer application by customer's technical experts. Motorola does not convey any license under its patent rights nor the rights of others. Motorola products are not designed, intended, or authorized for use as components in systems intended for surgical implant into the body, or other applications intended to support or sustain life, or for any other application in which the failure of the Motorola product could create a situation where personal injury or death may occur. Should Buyer purchase or use Motorola products for any such unintended or unauthorized application, Buyer shall indemnify and hold Motorola and its officers, employees, subsidiaries, affiliates, and distributors harmless against all claims, costs, damages, and expenses, and reasonable attorney fees arising out of, directly or indirectly, any claim of personal injury or death associated with such unintended or unauthorized use, even if such claim alleges that Motorola was negligent regarding the design or manufacture of the part. Motorola and are registered trademarks of Motorola, Inc. Motorola, Inc. is an Equal Opportunity/Affirmative Action Employer.

Mfax is a trademark of Motorola, Inc.

### How to reach us:

**USA/EUROPE/Locations Not Listed:** Motorola Literature Distribution;  
P.O. Box 5405, Denver, Colorado 80217. 303-675-2140 or 1-800-441-2447

**JAPAN:** Nippon Motorola Ltd.: SPD, Strategic Planning Office, 4-32-1,  
Nishi-Gotanda, Shinagawa-ku, Tokyo 141, Japan. 81-3-5487-8488

**Mfax™:** RMFAX0@email.sps.mot.com – TOUCHTONE 602-244-6609  
– US & Canada ONLY 1-800-774-1848

**ASIA/PACIFIC:** Motorola Semiconductors H.K. Ltd.; 8B Tai Ping Industrial Park,  
51 Ting Kok Road, Tai Po, N.T., Hong Kong. 852-26629298

**INTERNET:** <http://motorola.com/sps>



For More Information On This Product,  
Go to: [www.freescale.com](http://www.freescale.com)

MC13155/D

Freescale Semiconductor, Inc. ARCHIVED BY FREESCALE SEMICONDUCTOR, INC. 2005

ARCHIVE INFORMATION