

To our customers,

Old Company Name in Catalogs and Other Documents

On April 1st, 2010, NEC Electronics Corporation merged with Renesas Technology Corporation, and Renesas Electronics Corporation took over all the business of both companies. Therefore, although the old company name remains in this document, it is a valid Renesas Electronics document. We appreciate your understanding.

Renesas Electronics website: <http://www.renesas.com>

April 1st, 2010
Renesas Electronics Corporation

Issued by: Renesas Electronics Corporation (<http://www.renesas.com>)

Send any inquiries to <http://www.renesas.com/inquiry>.

Notice

1. All information included in this document is current as of the date this document is issued. Such information, however, is subject to change without any prior notice. Before purchasing or using any Renesas Electronics products listed herein, please confirm the latest product information with a Renesas Electronics sales office. Also, please pay regular and careful attention to additional and different information to be disclosed by Renesas Electronics such as that disclosed through our website.
2. Renesas Electronics does not assume any liability for infringement of patents, copyrights, or other intellectual property rights of third parties by or arising from the use of Renesas Electronics products or technical information described in this document. No license, express, implied or otherwise, is granted hereby under any patents, copyrights or other intellectual property rights of Renesas Electronics or others.
3. You should not alter, modify, copy, or otherwise misappropriate any Renesas Electronics product, whether in whole or in part.
4. Descriptions of circuits, software and other related information in this document are provided only to illustrate the operation of semiconductor products and application examples. You are fully responsible for the incorporation of these circuits, software, and information in the design of your equipment. Renesas Electronics assumes no responsibility for any losses incurred by you or third parties arising from the use of these circuits, software, or information.
5. When exporting the products or technology described in this document, you should comply with the applicable export control laws and regulations and follow the procedures required by such laws and regulations. You should not use Renesas Electronics products or the technology described in this document for any purpose relating to military applications or use by the military, including but not limited to the development of weapons of mass destruction. Renesas Electronics products and technology may not be used for or incorporated into any products or systems whose manufacture, use, or sale is prohibited under any applicable domestic or foreign laws or regulations.
6. Renesas Electronics has used reasonable care in preparing the information included in this document, but Renesas Electronics does not warrant that such information is error free. Renesas Electronics assumes no liability whatsoever for any damages incurred by you resulting from errors in or omissions from the information included herein.
7. Renesas Electronics products are classified according to the following three quality grades: “Standard”, “High Quality”, and “Specific”. The recommended applications for each Renesas Electronics product depends on the product’s quality grade, as indicated below. You must check the quality grade of each Renesas Electronics product before using it in a particular application. You may not use any Renesas Electronics product for any application categorized as “Specific” without the prior written consent of Renesas Electronics. Further, you may not use any Renesas Electronics product for any application for which it is not intended without the prior written consent of Renesas Electronics. Renesas Electronics shall not be in any way liable for any damages or losses incurred by you or third parties arising from the use of any Renesas Electronics product for an application categorized as “Specific” or for which the product is not intended where you have failed to obtain the prior written consent of Renesas Electronics. The quality grade of each Renesas Electronics product is “Standard” unless otherwise expressly specified in a Renesas Electronics data sheets or data books, etc.
 - “Standard”: Computers; office equipment; communications equipment; test and measurement equipment; audio and visual equipment; home electronic appliances; machine tools; personal electronic equipment; and industrial robots.
 - “High Quality”: Transportation equipment (automobiles, trains, ships, etc.); traffic control systems; anti-disaster systems; anti-crime systems; safety equipment; and medical equipment not specifically designed for life support.
 - “Specific”: Aircraft; aerospace equipment; submersible repeaters; nuclear reactor control systems; medical equipment or systems for life support (e.g. artificial life support devices or systems), surgical implantations, or healthcare intervention (e.g. excision, etc.), and any other applications or purposes that pose a direct threat to human life.
8. You should use the Renesas Electronics products described in this document within the range specified by Renesas Electronics, especially with respect to the maximum rating, operating supply voltage range, movement power voltage range, heat radiation characteristics, installation and other product characteristics. Renesas Electronics shall have no liability for malfunctions or damages arising out of the use of Renesas Electronics products beyond such specified ranges.
9. Although Renesas Electronics endeavors to improve the quality and reliability of its products, semiconductor products have specific characteristics such as the occurrence of failure at a certain rate and malfunctions under certain use conditions. Further, Renesas Electronics products are not subject to radiation resistance design. Please be sure to implement safety measures to guard them against the possibility of physical injury, and injury or damage caused by fire in the event of the failure of a Renesas Electronics product, such as safety design for hardware and software including but not limited to redundancy, fire control and malfunction prevention, appropriate treatment for aging degradation or any other appropriate measures. Because the evaluation of microcomputer software alone is very difficult, please evaluate the safety of the final products or system manufactured by you.
10. Please contact a Renesas Electronics sales office for details as to environmental matters such as the environmental compatibility of each Renesas Electronics product. Please use Renesas Electronics products in compliance with all applicable laws and regulations that regulate the inclusion or use of controlled substances, including without limitation, the EU RoHS Directive. Renesas Electronics assumes no liability for damages or losses occurring as a result of your noncompliance with applicable laws and regulations.
11. This document may not be reproduced or duplicated, in any form, in whole or in part, without prior written consent of Renesas Electronics.
12. Please contact a Renesas Electronics sales office if you have any questions regarding the information contained in this document or Renesas Electronics products, or if you have any other inquiries.

(Note 1) “Renesas Electronics” as used in this document means Renesas Electronics Corporation and also includes its majority-owned subsidiaries.

(Note 2) “Renesas Electronics product(s)” means any product developed or manufactured by or for Renesas Electronics.

1/4- to 1/11-DUTY FIP™ (VFD) CONTROLLER/DRIVER

DESCRIPTION

The μ PD16312 is a FIP (Fluorescent Indicator Panel, or Vacuum Fluorescent Display) controller/driver that is driven on a 1/4- to 1/11- duty factor. It consists of 11 segment output lines, 6 grid output lines, 5 segment/grid output drive lines, a display memory, a control circuit, and a key scan circuit. Serial data is input to the μ PD16312 through a three-line serial interface. This FIP controller/driver is ideal as a peripheral device for a single-chip microcomputer.

FEATURES

- Multiple display modes: 11-segment & 11-digit to 16-segment & 4-digit
- Key scanning: 6 x 4 matrix
- Dimming circuit: 8 steps
- High-withstanding-voltage output: $V_{DD} - 35$ V MAX.
- LED ports: 4 ch, 20 mA MAX.
- General input port: On-chip 4 bit
- No external resistors necessary for driver outputs: P-ch open-drain + pull-down resistor output
- Serial interface: CLK, STB, DIN, DOUT

ORDERING INFORMATION

Part Number	Package
μ PD16312GB-3B4, μ PD16312GB-3BS	44-pin Plastic QFP (10 x 10)

The information in this document is subject to change without notice. Before using this document, please confirm that this is the latest version.

Not all products and/or types are available in every country. Please check with an NEC Electronics sales representative for availability and additional information.

1. BLOCK DIAGRAM

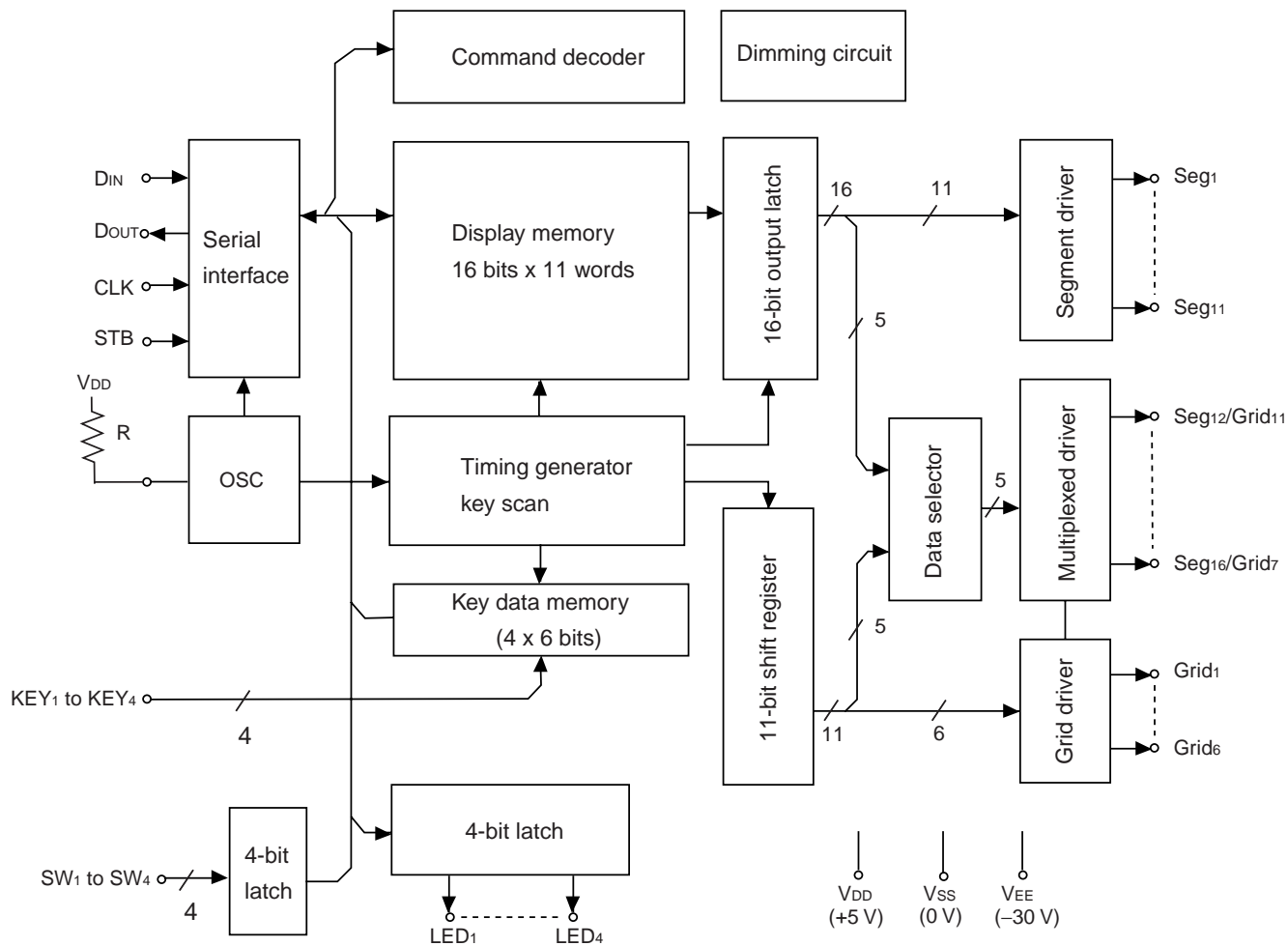

2. PIN CONFIGURATION (Top View)

44-pin Plastic QFP (10 x 10)

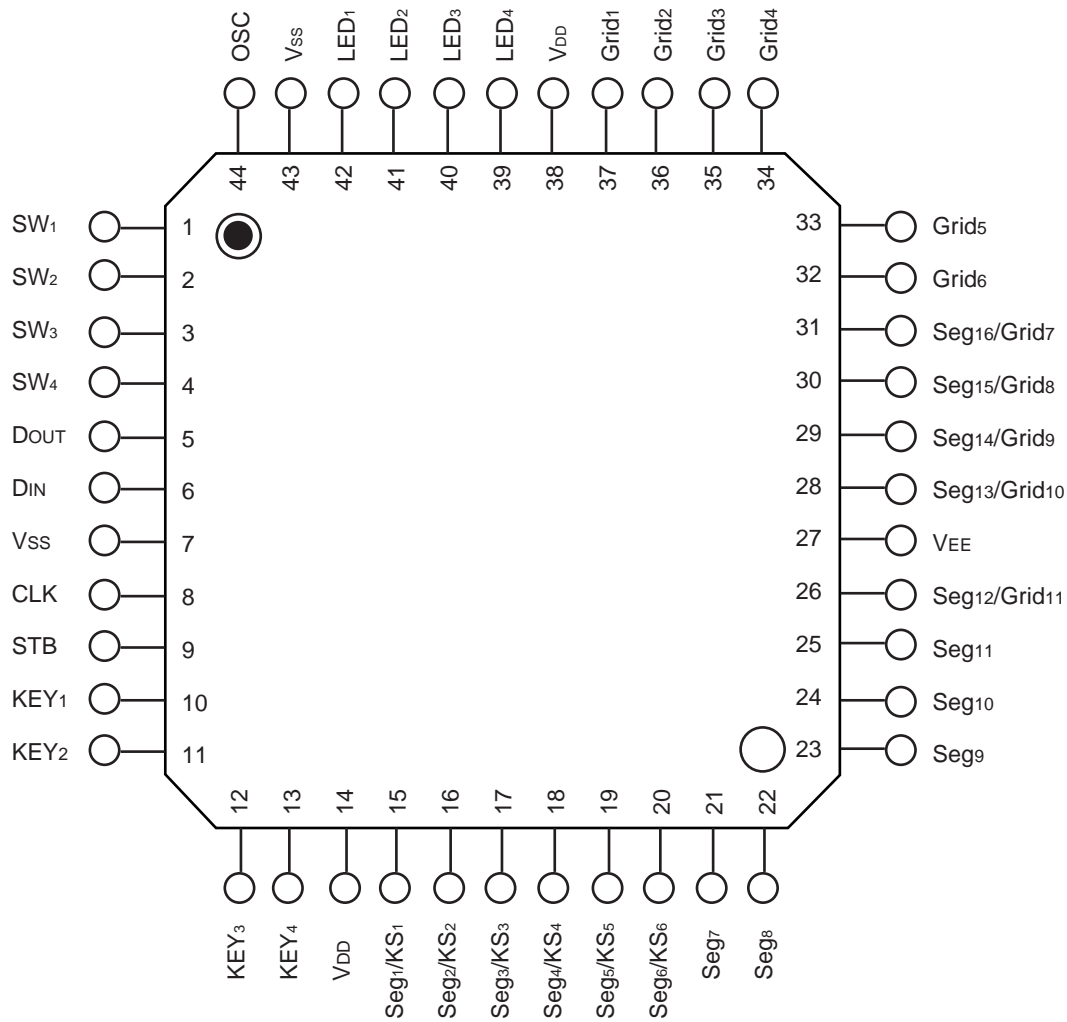

Caution Use all of the power supply pins.

3. PIN FUNCTION

Symbol	Pin Name	Pin No.	I/O	Description
D _{IN}	Data input	6	Input	Input serial data at rising edge of shift clock, starting from the low order bit.
D _{OUT}	Data output	5	Output	Output serial data at the falling edge of the shift clock, starting from low order bit. This is N-ch open-drain output pin.
STB	Strobe	9	Input	Initializes serial interface at the rising or falling edge of the μPD16312. It then waits for reception of a command. Data input after STB has fallen is processed as a command. While command data is processed, current processing is stopped, and the serial interface is initialized. While STB is high, CLK is ignored.
CLK	Clock input	8	Input	Reads serial data at the rising edge, and outputs data at the falling edge.
OSC	Oscillator	44	–	Connect external resistor to this pin to determine the oscillation frequency to this pin.
Seg ₁ /KS ₁ to Seg ₆ /KS ₆	High-withstanding-voltage output (Segment)	15 to 20	Output	Segment output pins (Dual function as key source)
Seg ₇ to Seg ₁₁	High-withstanding-voltage output (Segment)	21 to 25	Output	Segment output pins
Grid ₁ to Grid ₆	High-withstanding-voltage output (grid)	37 to 32	Output	Grid output pins
Seg ₁₂ /Grid ₁₁ to Seg ₁₆ /Grid ₇	High-withstanding-voltage output (segment/grid)	26, 28 to 31	Output	These pins are selectable for segment or grid driving.
LED ₁ to LED ₄	LED output	42 to 39	Output	CMOS output, +20 mA MAX.
KEY ₁ to KEY ₄	Key data input	10 to 13	Input	Data input to these pins is latched at the end of the display cycle.
SW ₁ to SW ₄	Switch input	1 to 4	Input	General input port for 4 bit.
V _{DD}	Logic power	14, 28	–	5 V ± 10%
V _{SS}	Logic ground	7, 43	–	Connect this pin to system GND.
V _{EE}	Pull-down level	27	–	V _{DD} – 35 V MAX.

4. DISPLAY RAM ADDRESS AND DISPLAY MODE

The display RAM stores the data transmitted to the μPD16312 through the serial communication. The addresses are allocated in 8-bit units.

Seg ₁	Seg ₄	Seg ₈	Seg ₁₂	Seg ₁₆	
00H _L	00H _U	01H _L	01H _U		DIG ₁
02H _L	02H _U	03H _L	03H _U		DIG ₂
04H _L	04H _U	05H _L	05H _U		DIG ₃
06H _L	06H _U	07H _L	07H _U		DIG ₄
08H _L	08H _U	09H _L	09H _U		DIG ₅
0AH _L	0AH _U	0BH _L	0BH _U		DIG ₆
0CH _L	0CH _U	0DH _L	0DH _U		DIG ₇
0EH _L	0EH _U	0FH _L	0FH _U		DIG ₈
10H _L	10H _U	11H _L	11H _U		DIG ₉
12H _L	12H _U	13H _L	13H _U		DIG ₁₀
14H _L	14H _U	15H _L	15H _U		DIG ₁₁

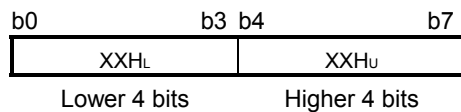

5. KEY MATRIX AND KEY-INPUT DATA STORAGE RAM

The key matrix is made up of a 6 x 4 matrix, as shown below.

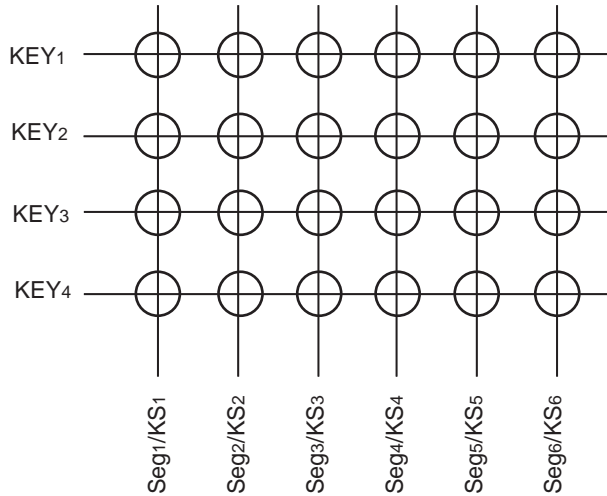

The data of each key is stored as follows, and is read with the read command starting from the least significant bit.

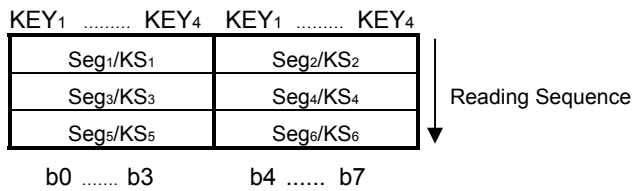

5.1 LED Port

Data is written to the LED port with the write command, starting from the least significant bit. “L” output when the bit of this port is 0, and “H” output when the bit is 1. The data of bits after the 5th bit are ignored.

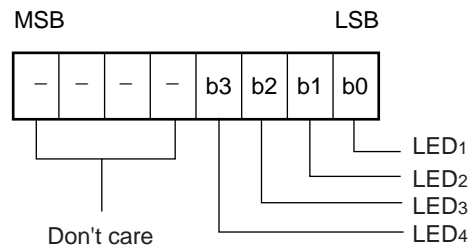

Remark Power ON application, all the LED ports are “L” output.

5.2 SW Data

SW data is read the read command, starting from the least significant bit. The data of bits after the 5th bit are inputted to 0.

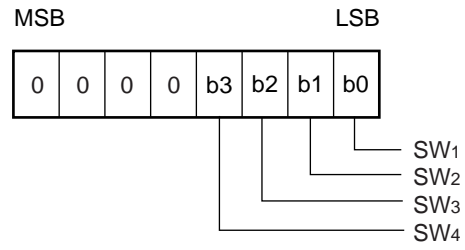

6. COMMANDS

Commands set the display mode and status of the FIP™ (VFD) driver.

The first 1 byte input to the μPD16312 through the D_{IN} pin after the STB pin has fallen is regarded as a command. If STB is set high while commands/data are transmitted, serial communication is initialized, and the commands/data being transmitted are invalid (however, the commands/data previously transmitted remain valid).

(1) Display mode setting commands

These commands initialize the μPD16312 and select the number of segments and the number of grids (1/4- to 1/11- duty, 11 segments to 16 segments).

When these commands are executed, the display is forcibly turned OFF, and key scanning is also stopped. To resume display, the display command “ON” must be executed. If the same mode is selected, however, nothing happens.

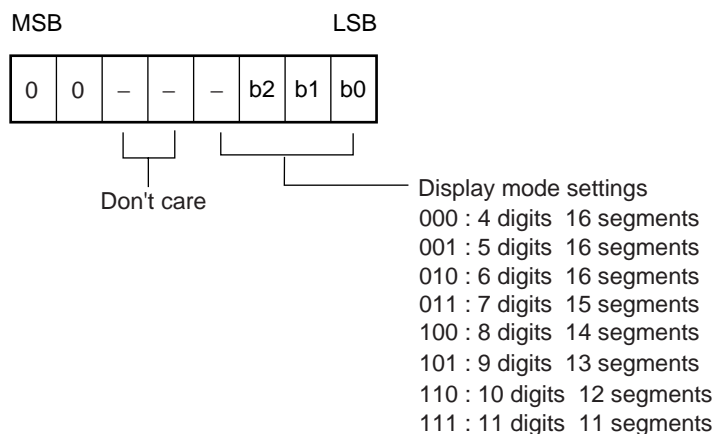

Remark Power ON application, the 11-digit, 11-segment mode is selected.

(2) Data setting commands

These commands set data write and data read modes.

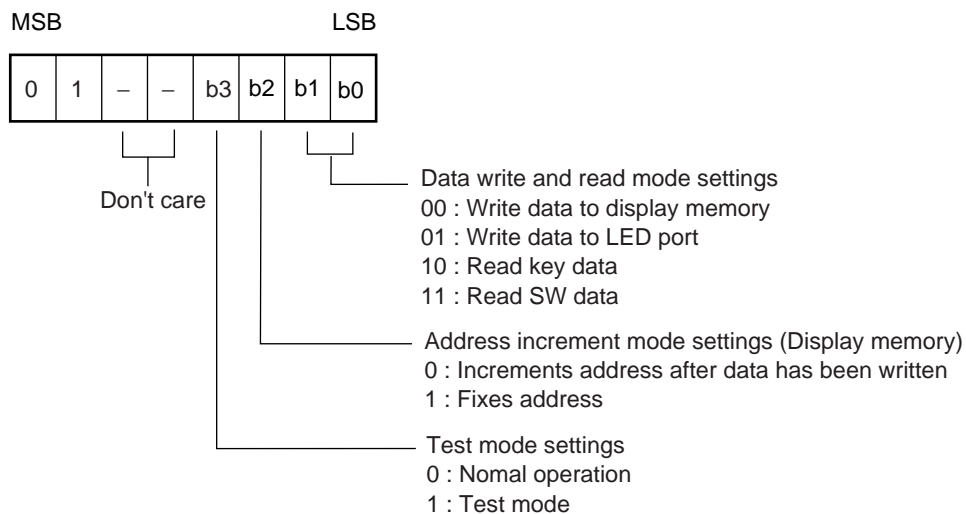

Remark Power ON application, the normal operation and address increment modes are set.

(3) Address setting commands

These commands set an address of the display memory.

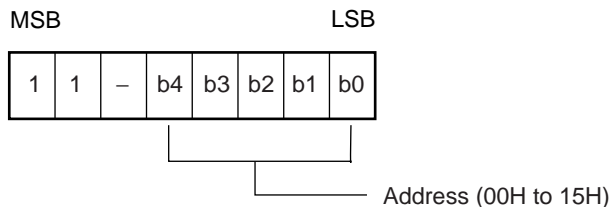

- Remarks**
1. If address 16H or higher is set, data is ignored, until a valid address is set.
 2. Power ON application, the address is set to 00H.

(4) Display control commands

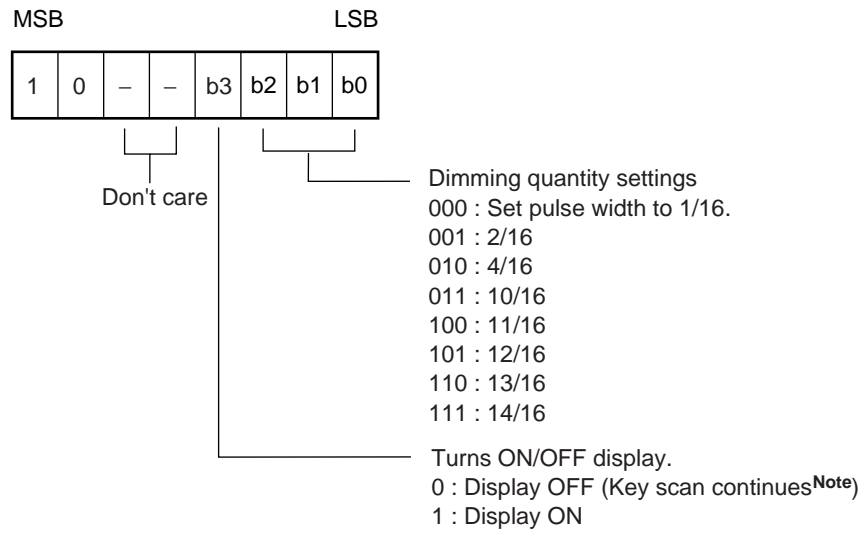

Note Power ON application, key scanning is stopped.

Remark Power ON application, the 1/16 pulse width is set and the display is turned OFF.

7. KEY SCANNING AND DISPLAY TIMING

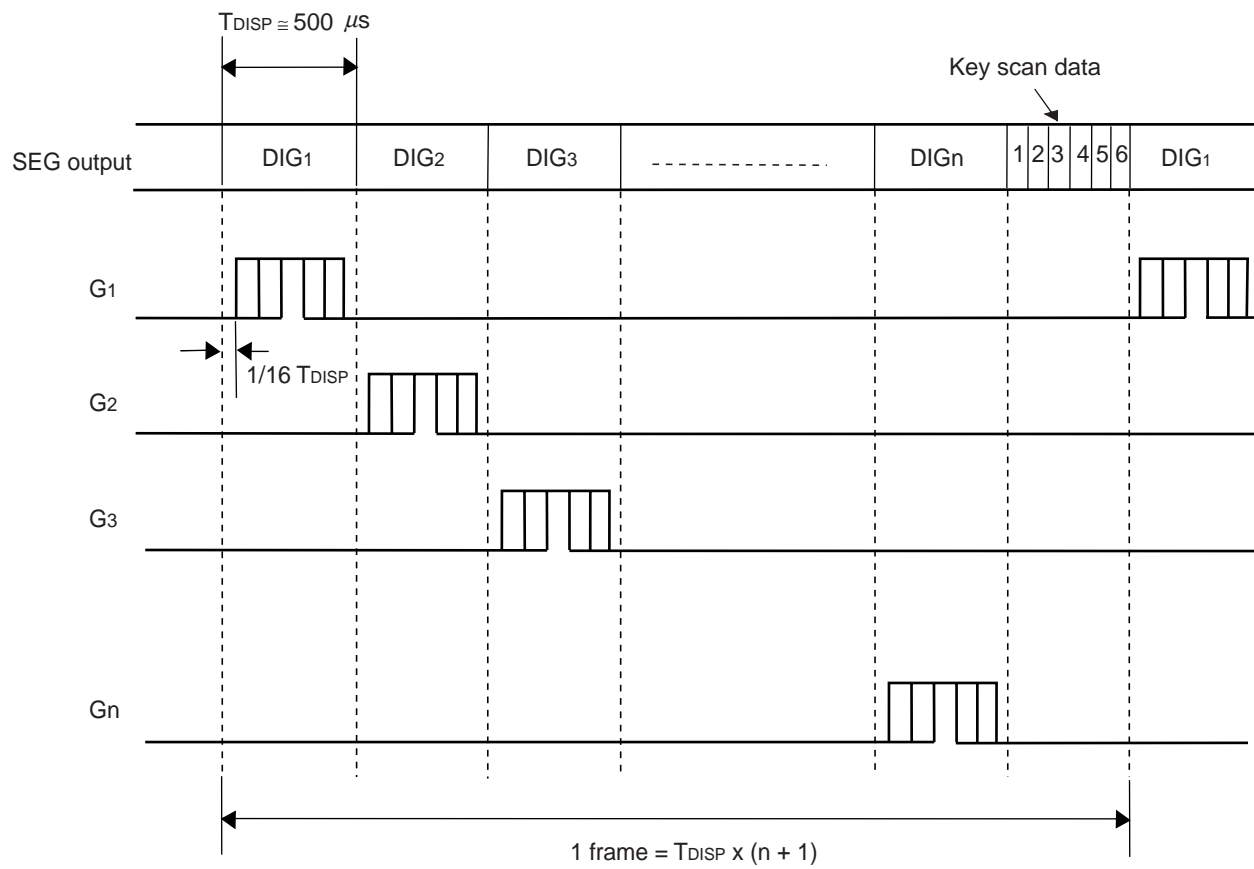

Remark One cycle of key scanning consists of one frame, and data in a 6 x 4 matrix is stored in RAM.

8. SERIAL COMMUNICATION FORMAT

Reception (command/data write)

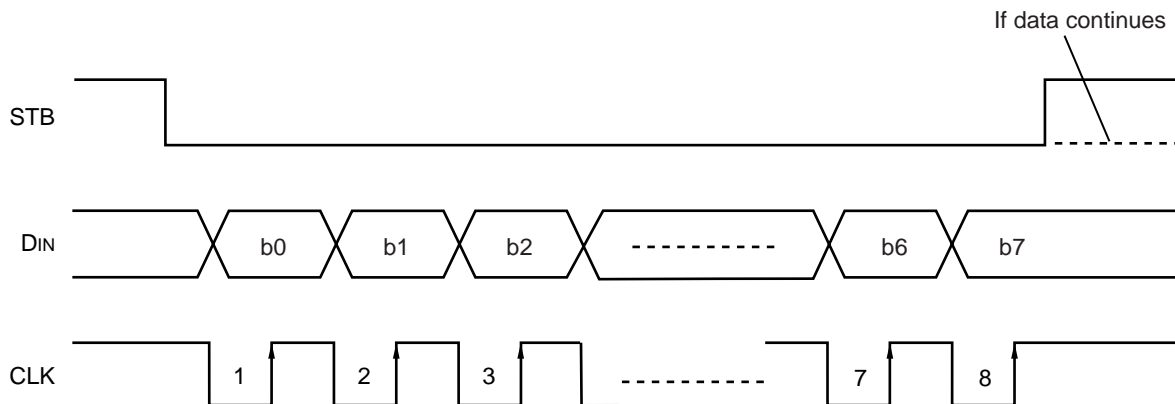

Transmission (data read)

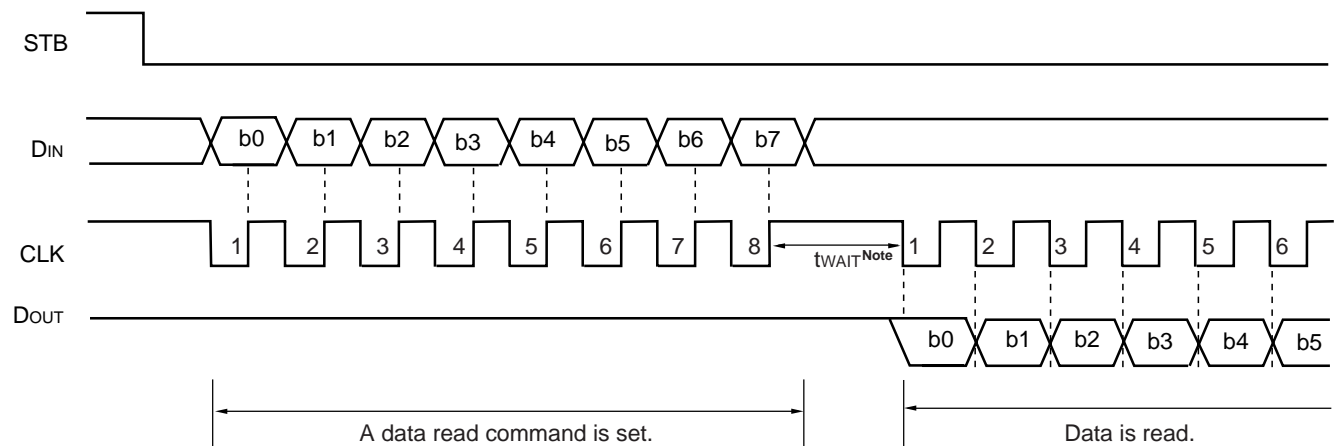

Note When data is read, a wait time t_{WAIT} of 1 μs is necessary since the rising of the eighth clock that has set the command, until the falling of the first clock that has read the data.

Remark Because the DOUT pin is an N-ch, open-drain output pin, be sure to connect an external pull-up resistor (1 to 10 k Ω) to this pin.

9. ELECTRICAL SPECIFICATIONS

Absolute Maximum Ratings (T_A = 25°C, V_{SS} = 0 V)

Parameter	Symbol	Ratings	Unit
Logic Supply Voltage	V _{DD}	-0.5 to +7.0	V
Driver Supply Voltage	V _{EE}	V _{DD} + 0.5 to V _{DD} - 40	V
Logic Input Voltage	V _{I1}	-0.5 to V _{DD} + 0.5	V
FIP Driver Output Voltage	V _{O2}	V _{EE} - 0.5 to V _{DD} + 0.5	V
LED Driver Output Current	I _{O1}	+25	mA
FIP Driver Output Current	I _{O2}	-40 (grid) -15 (segment)	mA
Power Dissipation	P _D	800 ^{Note}	mW
Operating Ambient Temperature	T _A	-40 to +85	°C
Storage Temperature	T _{stg}	-65 to +150	°C

Note Derate at -6.4 mW/°C at T_A = 25°C or higher.

Caution Product quality may suffer if the absolute maximum rating is exceeded even momentarily for any parameter. That is, the absolute maximum ratings are rated values at which the product is on the verge of suffering physical damage, and therefore the product must be used under conditions that ensure that the absolute maximum ratings are not exceeded.

Recommended Operating Range (T_A = -20 to +70°C, V_{SS} = 0 V)

Parameter	Symbol	Conditions	MIN.	TYP.	MAX.	Unit
Logic Supply Voltage	V _{DD}		4.5	5	5.5	V
High-Level Input Voltage	V _{IH}		0.7 V _{DD}		V _{DD}	V
Low-Level Input Voltage	V _{IL}		0		0.3 V _{DD}	V
Driver Supply Voltage	V _{EE}		0		V _{DD} - 35	V

Remark Maximum power consumption P_{MAX.} = FIP driver dissipation + R_L dissipation + LED driver dissipation + dynamic power consumption

Where segment current = 3 mA, grid current = 15 mA, and LED current = 20 mA,

FIP driver dissipation = number of segments x 6 + number of grids/(number of grids + 1) x 30 (mW)

R_L dissipation = (V_{DD} - V_{EE})²/50 x (number of segments + 1) (mW)

LED driver dissipation = number of LEDs x 20 (mW)

Dynamic power consumption = V_{DD} x 5 (mW)

Sample

V_{EE} = -25 V, V_{DD} = 5 V, 16 segment, 6-digits mode

FIP driver dissipation = 16 x 6 + 6/7 x 30 = 122

R_L dissipation = 30²/50 x 17 = 306

LED driver dissipation = 4 x 20 = 80

Dynamic power consumption = 5 x 5 = 25

Total 533 mW

Electrical Characteristics (T_A = -20 to +70°C, V_{DD} = 4.5 to 5.5 V, V_{SS} = 0 V, V_{EE} = V_{DD} - 35 V)

Parameter	Symbol	Conditions	MIN.	TYP.	MAX.	Unit
High-Level Output Voltage	V _{OH1}	LED ₁ to LED ₄ , I _{OH1} = -1 mA	0.9 V _{DD}			V
Low-Level Output Voltage	V _{OL1}	LED ₁ to LED ₄ , I _{OL1} = +20 mA			1	V
Low-Level Output Voltage	V _{OL2}	D _{OUT} , I _{OL2} = 4 mA			0.4	V
High-Level Output Current	I _{OH21}	V _O = V _{DD} - 2 V, Seg ₁ to Seg ₁₁	-3			mA
High-Level Output Current	I _{OH22}	V _O = V _{DD} - 2 V, Grid ₁ to Grid ₆ , Seg ₁₂ /Grid ₁₁ to Seg ₁₆ /Grid ₇	-15			mA
Driver Leakage Current	I _{OLEAK}	V _O = V _{DD} - 35 V, driver OFF			-10	μA
Output Pull-Down Resistor	R _L	Driver output	50	100	150	kΩ
Input Current	I _I	V _I = V _{DD} or V _{SS}			±1	μA
High-Level Input Voltage	V _{IH}		0.7 V _{DD}			V
Low-Level Input Voltage	V _{IL}				0.3 V _{DD}	V
Hysteresis Voltage	V _H	CLK, D _{IN} , STB		0.35		V
Dynamic Current Consumption	I _{DDdyn}	No load, display OFF			5	mA

Switching Characteristics (T_A = -20 to +70°C, V_{DD} = 4.5 to 5.5 V, V_{EE} = -30 V)

Parameter	Symbol	Conditions	MIN.	TYP.	MAX.	Unit
Oscillation Frequency	f _{OSC}	R = 51 kΩ	350	500	650	kHz
Propagation Delay Time	t _{PLZ}	CLK → D _{OUT}			300	ns
	t _{PZL}	C _L = 15 pF, R _L = 10 kΩ			100	ns
Rise Time	t _{TZH1}	C _L = 300 pF Seg ₁ to Seg ₁₁ Grid ₁ to Grid ₆ , Seg ₁₂ /Grid ₁₁ to Seg ₁₆ /Grid ₇			2	μs
	t _{TZH2}				0.5	μs
Fall Time	t _{THZ}	C _L = 300 pF, Seg _n , Grid _n			120	μs
Maximum Clock Frequency	f _{MAX}	Duty = 50%	1			MHz
Input Capacitance	C _I				15	pF

Timing Conditions (T_A = -20 to +70°C, V_{DD} = 4.5 to 5.5 V)

Parameter	Symbol	Conditions	MIN.	TYP.	MAX.	Unit
Clock Pulse Width	PW _{CLK}		400			ns
Strobe Pulse Width	PW _{STB}		1			μs
Data Setup Time	t _{SETUP}		100			ns
Data Hold Time	t _{HOLD}		100			ns
Clock-Strobe Time	t _{CLK-STB}	CLK ↑ → STB ↑	1			μs
Wait Time	t _{WAIT}	CLK ↑ → CLK ↓ ^{Note}	1			μs

Note Refer to the 8. SERIAL COMMUNICATION FORMAT.

Switching Characteristic Waveforms

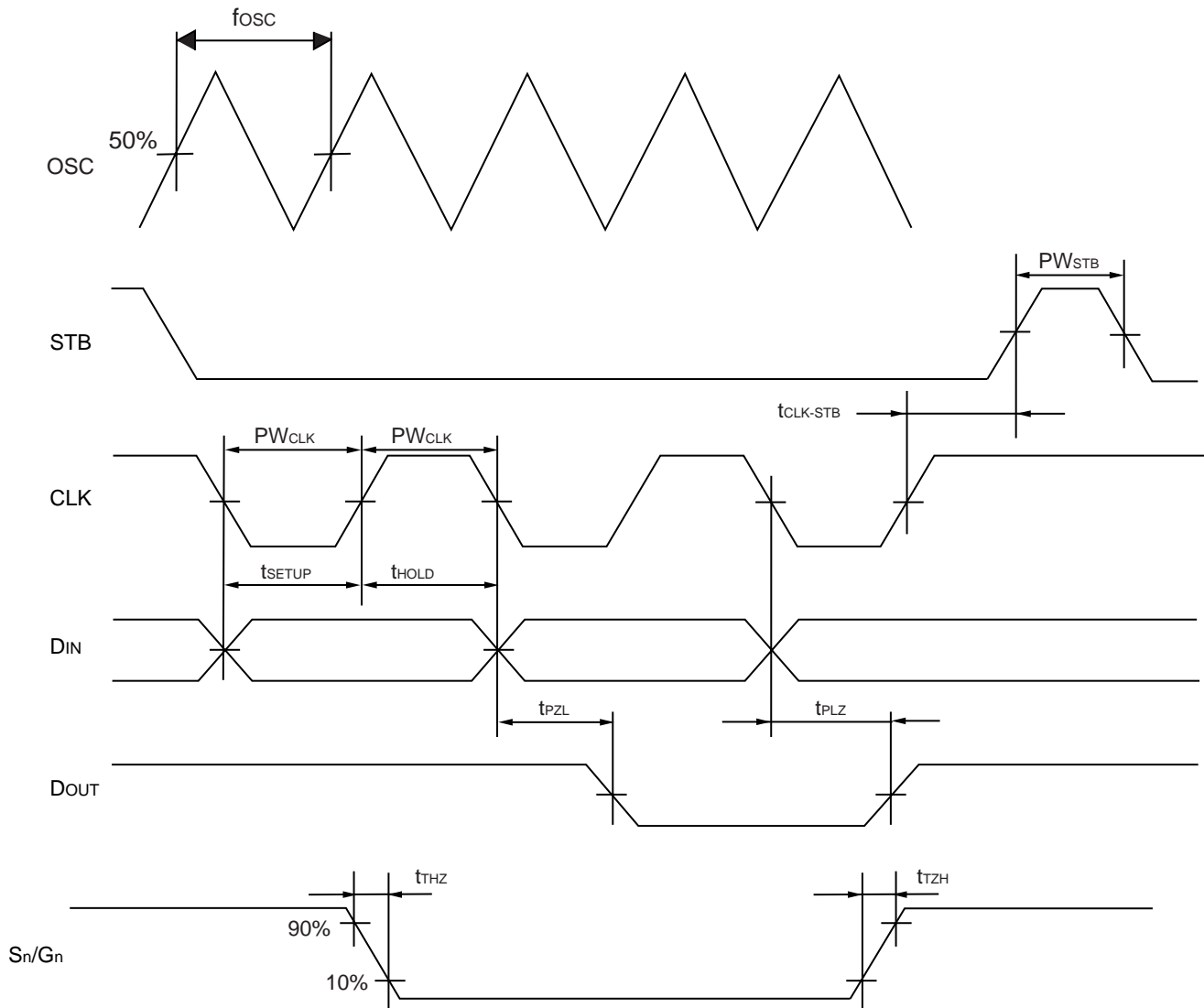

Electrical Curve Line (Unless otherwise specified, $T_A = +25^\circ\text{C}$, $V_{DD} = +5.0\text{ V}$, $V_{EE} = V_{DD} - 35\text{ V}$)

Output voltage-Current specification
(Seg₁ to Seg₁₁)

Drop voltage $\Delta V_{O}^{\text{Note}}$ (V)

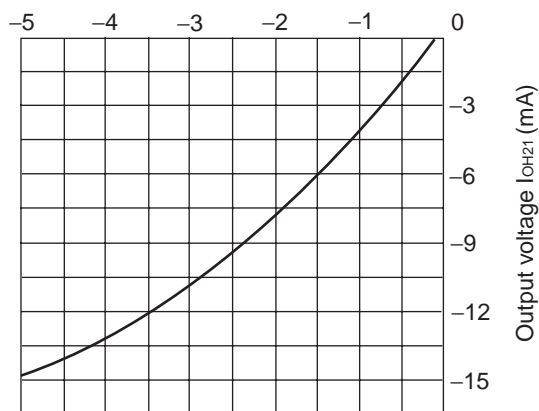

Note $\Delta V_{O} = V_{DD} - V_{O}$

Oscillator frequency-External resistance specification

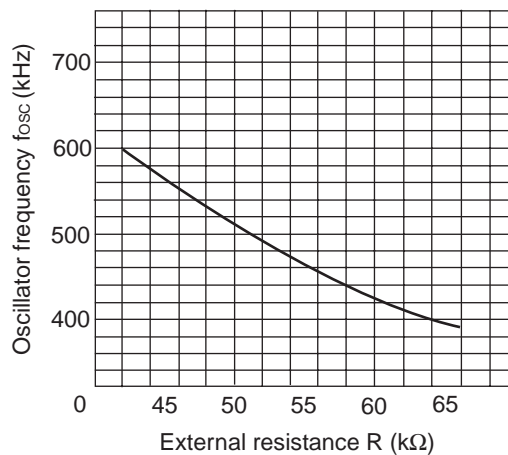

Output voltage-Current specification
(Grid₁ to Grid₆, Seg₁₂/Grid₁₁ to Seg₁₆/Grid₇)

Drop voltage $\Delta V_{O}^{\text{Note}}$ (V)

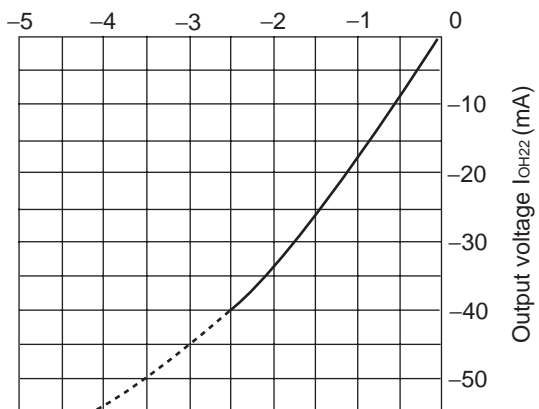

Note $\Delta V_{O} = V_{DD} - V_{O}$

10. APPLICATIONS

Updating display memory by incrementing address

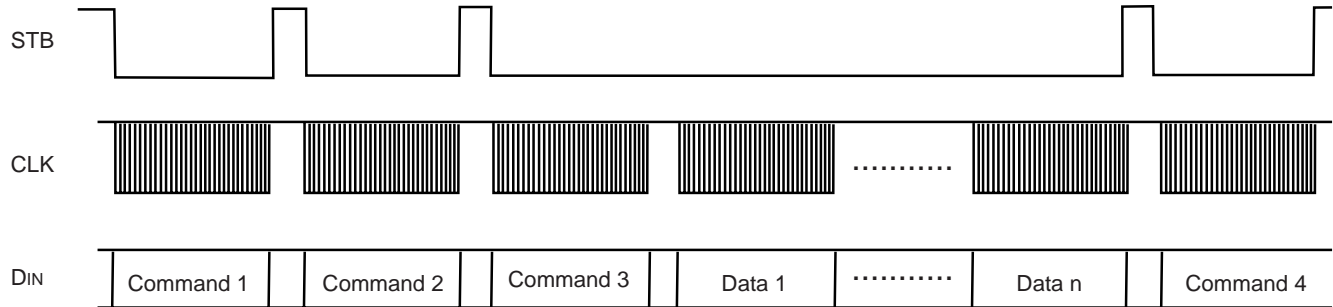

- Command 1 : Sets display mode
- Command 2 : Sets data
- Command 3 : Sets address
- Data 1 to n : Transfers display data (22 bytes MAX.)
- Command 4 : Controls display

Updating specific address

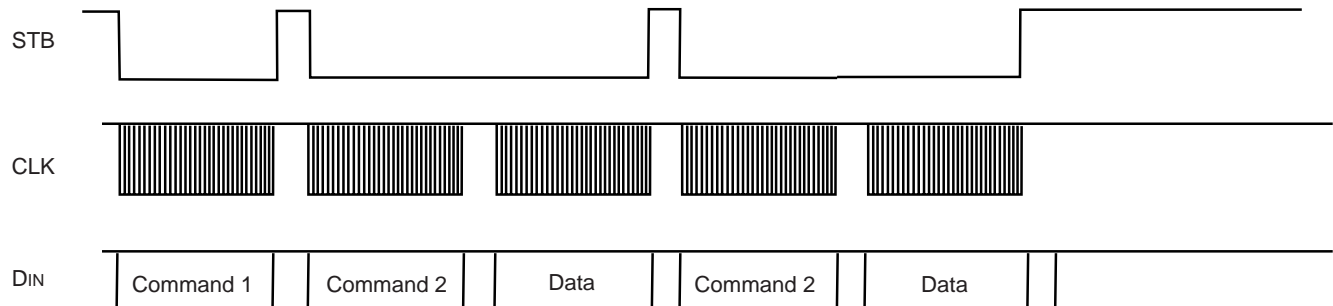

- Command 1 : Sets data
- Command 2 : Sets address
- Data : Display data

11. CIRCUIT EXAMPLE FOR APPLICATION (6 digit, 16 segment)

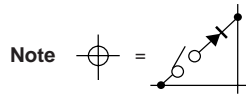
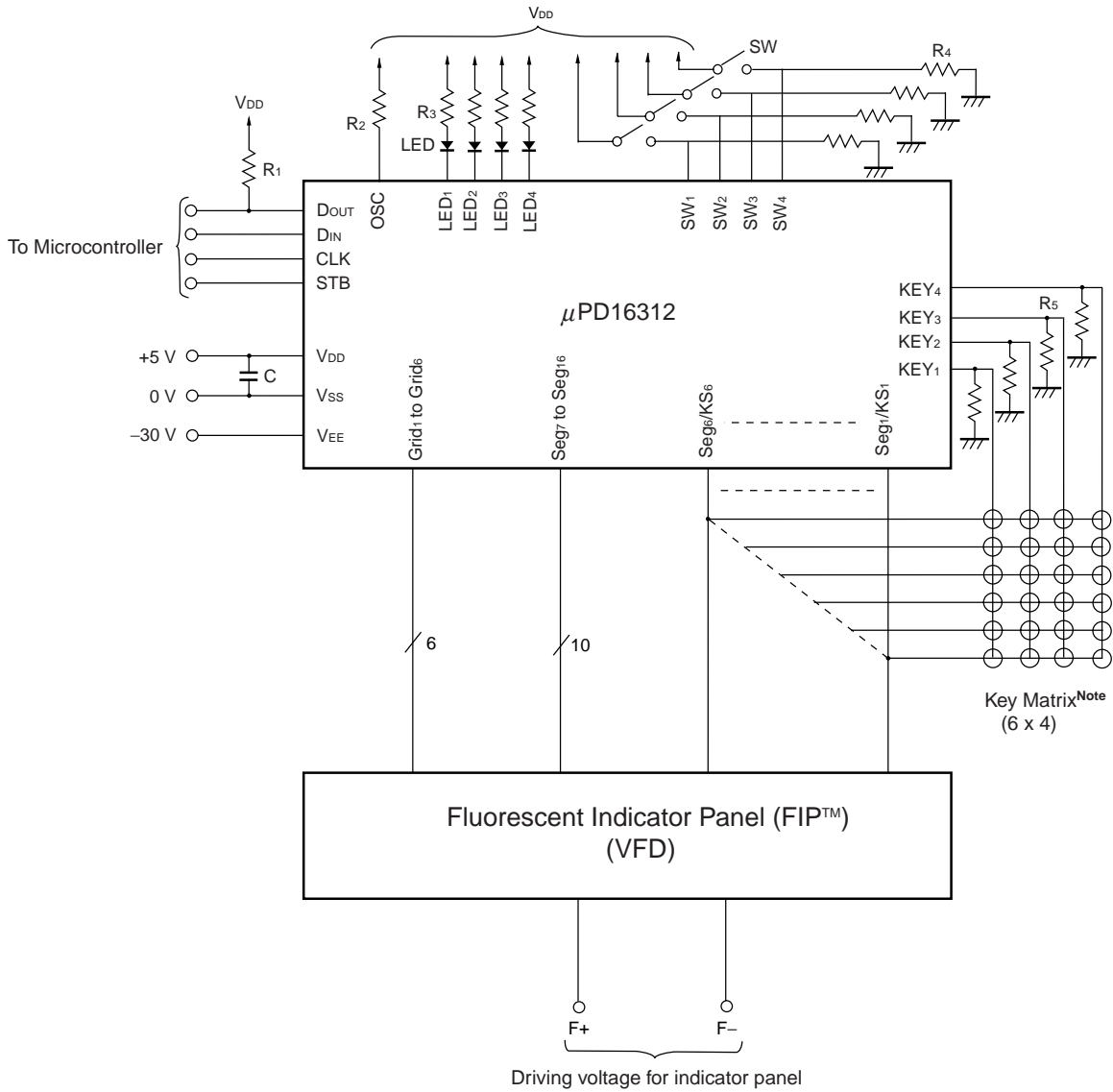

Remark R1, R4, R5 = 1 k to 10 kΩ
 R2 = 51 kΩ
 R3 = 330 to 1 kΩ
 C = 0.1 μ to 1.0 μF

Caution The application circuit and circuit constant of printing are shown in illustration, and are not aimed at a mass-production design.

12. PACKAGE DRAWING

• μPD16312GB-3B4

44-PIN PLASTIC QFP (10x10)

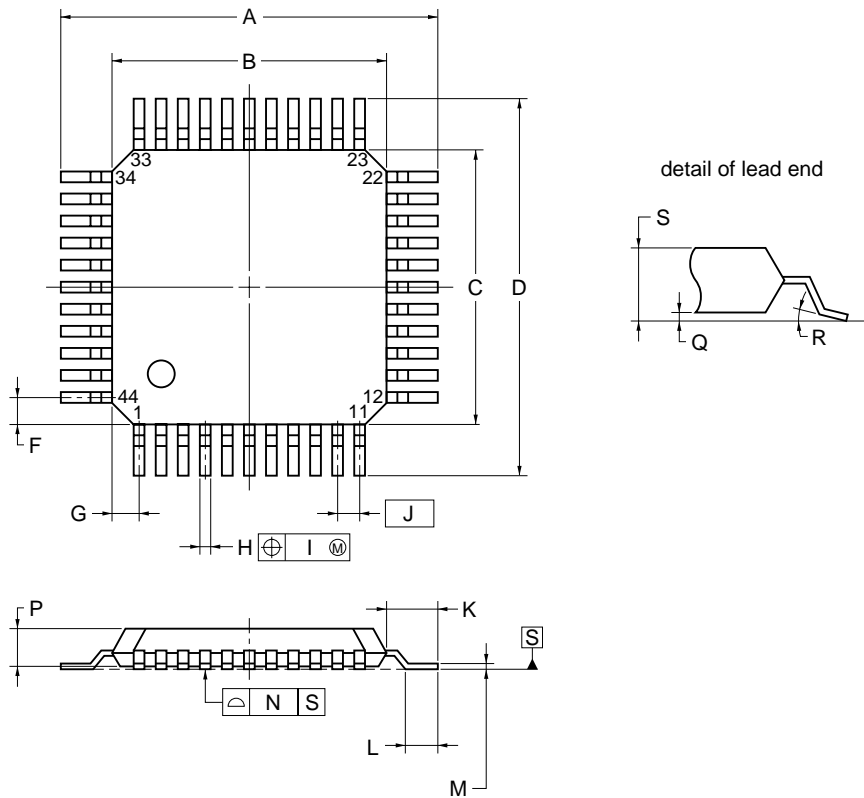

NOTE

Each lead centerline is located within 0.15 mm of its true position (T.P.) at maximum material condition.

ITEM	MILLIMETERS
A	13.2±0.4
B	10.0±0.2
C	10.0±0.2
D	13.2±0.4
F	1.0
G	1.0
H	0.35±0.10
I	0.15
J	0.8 (T.P.)
K	1.6±0.2
L	0.8±0.2
M	0.15 ^{+0.10} _{-0.05}
N	0.10
P	2.7
Q	0.1±0.1
R	5°±5°
S	3.0 MAX.

S44GB-80-3B4-3

• μPD16312GB-3BS

44-PIN PLASTIC QFP (10x10)

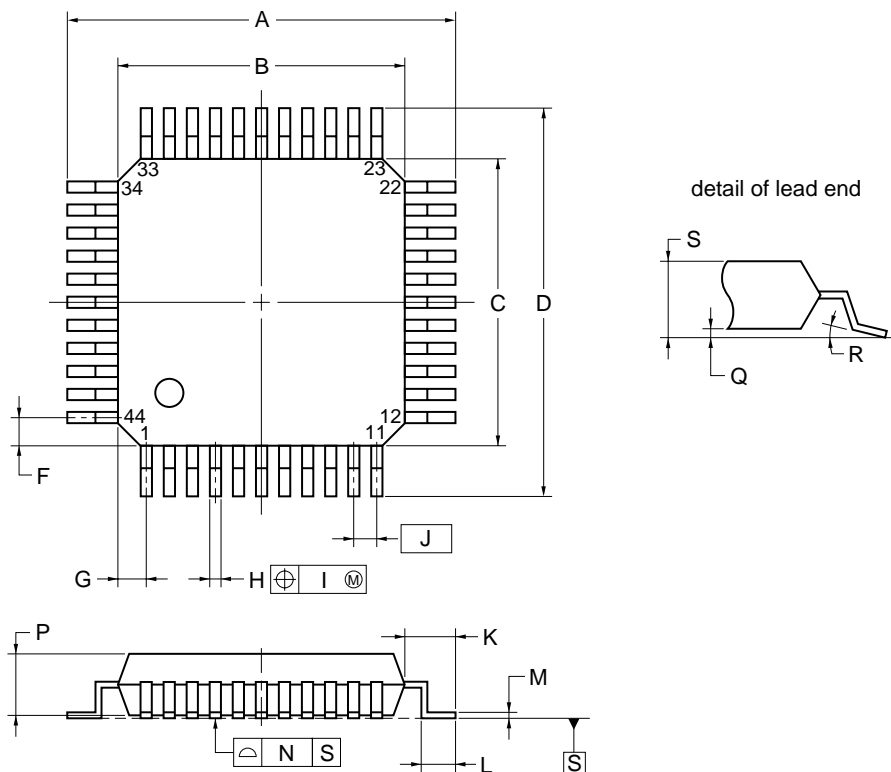

NOTE

Each lead centerline is located within 0.16 mm of its true position (T.P.) at maximum material condition.

ITEM	MILLIMETERS
A	13.2±0.2
B	10.0±0.2
C	10.0±0.2
D	13.2±0.2
F	1.0
G	1.0
H	0.37 ^{+0.08} _{-0.07}
I	0.16
J	0.8 (T.P.)
K	1.6±0.2
L	0.8±0.2
M	0.17 ^{+0.06} _{-0.05}
N	0.10
P	2.7±0.1
Q	0.125±0.075
R	3 ^{+7°} _{-3°}
S	3.0 MAX.

S44GB-80-3BS-2

13. RECOMMENDED SOLDERING CONDITIONS

The following conditions must be met for mounting conditions of the μPD16312.

For more details, refer to the

Semiconductor Device Mount Manual (<http://www.necel.com/pkg/en/mount/index.html>)

Please consult with our sales offices in case other mounting process is used, or in case the mounting is done under different conditions.

Type of Surface Mount Device

μPD16312GB-3B4, μPD16312GB-3BS: 44-pin plastic QFP (10 x 10)

Soldering process	Soldering conditions	Symbol
Infrared ray reflow	Peak package's surface temperature: 235°C or below, Reflow time: 30 seconds or below (210°C or higher), Number of reflow process: MAX.3	IR35-00-2
VPS	Peak package's temperature: 215°C or below, Reflow time: 25 to 40 seconds (200°C or higher), Number of reflow process: MAX.3	VP15-00-2
Wave Soldering	Solder temperature: 260°C or below, Flow time: 10 seconds or below Temperature of pre-heat: 120°C or below (Plastic surface temperature) Number of flow process: 1	WS60-00-1
Partial heating method	Terminal temperature: 300°C or below, Time 3 seconds or below (per side of pin position)	-

Caution Do not apply more than a single process at once, except for partial heating method.

NOTES FOR CMOS DEVICES

① VOLTAGE APPLICATION WAVEFORM AT INPUT PIN

Waveform distortion due to input noise or a reflected wave may cause malfunction. If the input of the CMOS device stays in the area between V_{IL} (MAX) and V_{IH} (MIN) due to noise, etc., the device may malfunction. Take care to prevent chattering noise from entering the device when the input level is fixed, and also in the transition period when the input level passes through the area between V_{IL} (MAX) and V_{IH} (MIN).

② HANDLING OF UNUSED INPUT PINS

Unconnected CMOS device inputs can be cause of malfunction. If an input pin is unconnected, it is possible that an internal input level may be generated due to noise, etc., causing malfunction. CMOS devices behave differently than Bipolar or NMOS devices. Input levels of CMOS devices must be fixed high or low by using pull-up or pull-down circuitry. Each unused pin should be connected to V_{DD} or GND via a resistor if there is a possibility that it will be an output pin. All handling related to unused pins must be judged separately for each device and according to related specifications governing the device.

③ PRECAUTION AGAINST ESD

A strong electric field, when exposed to a MOS device, can cause destruction of the gate oxide and ultimately degrade the device operation. Steps must be taken to stop generation of static electricity as much as possible, and quickly dissipate it when it has occurred. Environmental control must be adequate. When it is dry, a humidifier should be used. It is recommended to avoid using insulators that easily build up static electricity. Semiconductor devices must be stored and transported in an anti-static container, static shielding bag or conductive material. All test and measurement tools including work benches and floors should be grounded. The operator should be grounded using a wrist strap. Semiconductor devices must not be touched with bare hands. Similar precautions need to be taken for PW boards with mounted semiconductor devices.

④ STATUS BEFORE INITIALIZATION

Power-on does not necessarily define the initial status of a MOS device. Immediately after the power source is turned ON, devices with reset functions have not yet been initialized. Hence, power-on does not guarantee output pin levels, I/O settings or contents of registers. A device is not initialized until the reset signal is received. A reset operation must be executed immediately after power-on for devices with reset functions.

⑤ POWER ON/OFF SEQUENCE

In the case of a device that uses different power supplies for the internal operation and external interface, as a rule, switch on the external power supply after switching on the internal power supply. When switching the power supply off, as a rule, switch off the external power supply and then the internal power supply. Use of the reverse power on/off sequences may result in the application of an overvoltage to the internal elements of the device, causing malfunction and degradation of internal elements due to the passage of an abnormal current.

The correct power on/off sequence must be judged separately for each device and according to related specifications governing the device.

⑥ INPUT OF SIGNAL DURING POWER OFF STATE

Do not input signals or an I/O pull-up power supply while the device is not powered. The current injection that results from input of such a signal or I/O pull-up power supply may cause malfunction and the abnormal current that passes in the device at this time may cause degradation of internal elements. Input of signals during the power off state must be judged separately for each device and according to related specifications governing the device.

Reference Documents**NEC Semiconductor Device Reliability/Quality Control System (C10983E)****Quality Grades On NEC Semiconductor Devices (C11531E)**

FIP™ is a trademark of NEC Corporation

- **The information in this document is current as of December 2004. The information is subject to change without notice. For actual design-in, refer to the latest publications of NEC Electronics data sheets or data books, etc., for the most up-to-date specifications of NEC Electronics products. Not all products and/or types are available in every country. Please check with an NEC Electronics sales representative for availability and additional information.**
- No part of this document may be copied or reproduced in any form or by any means without the prior written consent of NEC Electronics. NEC Electronics assumes no responsibility for any errors that may appear in this document.
- NEC Electronics does not assume any liability for infringement of patents, copyrights or other intellectual property rights of third parties by or arising from the use of NEC Electronics products listed in this document or any other liability arising from the use of such products. No license, express, implied or otherwise, is granted under any patents, copyrights or other intellectual property rights of NEC Electronics or others.
- Descriptions of circuits, software and other related information in this document are provided for illustrative purposes in semiconductor product operation and application examples. The incorporation of these circuits, software and information in the design of a customer's equipment shall be done under the full responsibility of the customer. NEC Electronics assumes no responsibility for any losses incurred by customers or third parties arising from the use of these circuits, software and information.
- While NEC Electronics endeavors to enhance the quality, reliability and safety of NEC Electronics products, customers agree and acknowledge that the possibility of defects thereof cannot be eliminated entirely. To minimize risks of damage to property or injury (including death) to persons arising from defects in NEC Electronics products, customers must incorporate sufficient safety measures in their design, such as redundancy, fire-containment and anti-failure features.
- NEC Electronics products are classified into the following three quality grades: "Standard", "Special" and "Specific".

The "Specific" quality grade applies only to NEC Electronics products developed based on a customer-designated "quality assurance program" for a specific application. The recommended applications of an NEC Electronics product depend on its quality grade, as indicated below. Customers must check the quality grade of each NEC Electronics product before using it in a particular application.

"Standard": Computers, office equipment, communications equipment, test and measurement equipment, audio and visual equipment, home electronic appliances, machine tools, personal electronic equipment and industrial robots.

"Special": Transportation equipment (automobiles, trains, ships, etc.), traffic control systems, anti-disaster systems, anti-crime systems, safety equipment and medical equipment (not specifically designed for life support).

"Specific": Aircraft, aerospace equipment, submersible repeaters, nuclear reactor control systems, life support systems and medical equipment for life support, etc.

The quality grade of NEC Electronics products is "Standard" unless otherwise expressly specified in NEC Electronics data sheets or data books, etc. If customers wish to use NEC Electronics products in applications not intended by NEC Electronics, they must contact an NEC Electronics sales representative in advance to determine NEC Electronics' willingness to support a given application.

(Note)

- (1) "NEC Electronics" as used in this statement means NEC Electronics Corporation and also includes its majority-owned subsidiaries.
- (2) "NEC Electronics products" means any product developed or manufactured by or for NEC Electronics (as defined above).