

2.4-6.0V Input	0.75-3.6V Outputs	10 Amp Current	Non Isolated	SMT Surface Mount
---------------------------	------------------------------	---------------------------	-------------------------	------------------------------

The NiQor® SMT DC/DC converter is a non-isolated buck regulator which employs synchronous rectification to achieve extremely high conversion efficiency. The NiQor family of converters is used predominately in DPA systems using a front end DC/DC high power brick (48Vin to low voltage bus). These non-isolated converters are then used at the point of load to create the low voltage outputs required by the design. The wide trim module can be programmed to a variety of output voltages through the use of a single external resistor. RoHS compliant (see page 12).

NiQor®

Non-Isolated



NQ04W33SKA10 wide trim module



Operational Features

- Ultra high efficiency, up to 95% at full rated load
- Delivers up to 10 Amps of output current with minimal derating - no heatsink required
- Input Voltage Range : 2.4 - 6.0V
- Programmable output voltages from 0.75 - 3.6V
- On-board input and output filter capacitor
- No minimum load requirement means no preload resistors required

Mechanical Features

- DOSA standard SMT pin-out configuration
- Industry standard size: 1.3" x 0.53" x 0.29" (33 x 13.5 x 7.3 mm)
- Available in SIP configuration
- Total weight: 0.18 oz. (5 grams), lower mass greatly reduces vibration and shock problems
- Open frame construction maximizes air flow cooling

Control Features

- On/Off control
- Output voltage trim (industry standard) permits custom voltages and voltage margining
- Remote Sense (standard option)

Protection Features

- Input under-voltage lockout disables converter at low input voltage conditions
- Temperature compensated over-current shutdown protects converter from excessive load current or short circuits
- Output over-voltage protection protects load from damaging voltages
- Thermal shutdown protects converter from abnormal environmental conditions

Safety Features

- UL/cUL 60950-1 recognized (US & Canada)
- TUV certified to EN60950-1
- Meets 72/23/EEC and 93/68/EEC directives which facilitates CE Marking in user's end product
- Board and plastic components meet UL94V-0 flammability requirements

MECHANICAL DIAGRAM

Surface Mount Package

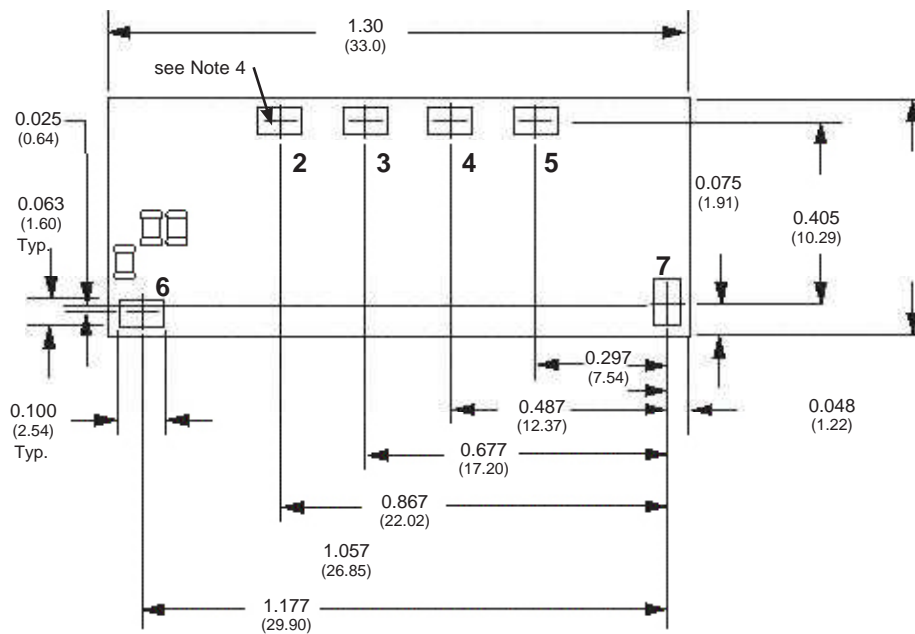

Bottom View

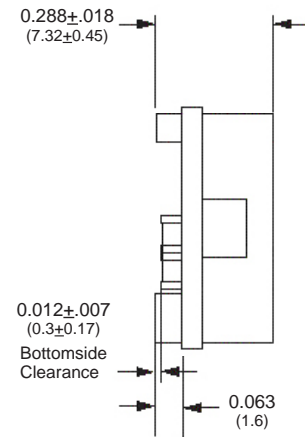

Side View

Recommended SMT Pad Size:

Minimum: 0.074" x 0.122" (1.88mm x 3.1mm)
 Maximum: 0.095" x 0.140" (2.41mm x 3.56mm)

NOTES

- 1) SMT Contacts: Material - Brass
Finish - Gold over Nickel plate
- 2) Undimensioned components are shown for visual reference only.
- 3) All dimensions in inches (mm)
Tolerances: x.xx +/-0.02 in. (x.x +/-0.5mm)
x.xxx +/-0.010 in. (x.xx +/-0.25mm)
- 4) Coplanarity for pins 1-7 is 0.004" max
- 5) Weight: 0.18 oz. (5 g) typical
- 6) Workmanship: Meets or exceeds IPC-A-610C Class II

SMT CONTACT DESIGNATIONS

Pin No.	Name	Function
2	GND	Ground
3	Vout(+)	Positive output voltage
4	TRIM	Output Voltage Trim
5	<i>SENSE(+)</i>	<i>Positive remote sense</i>
6	Vin(+)	Positive input voltage
7	ON/OFF	Input to turn converter on/off

Pins in Italics Shaded text are Optional



Technical Specification

Input: 2.4 - 6.0V
Outputs: 0.75 - 3.6V
Current: 10A
Package: SMT

ELECTRICAL CHARACTERISTICS - NQ04W33SKA10 Series

V_{in} =3.3Vdc and 5.0Vdc except 3.3V_{out} units where V_{in} =5.0V; T_A =25°C, airflow rate=300 LFM unless otherwise noted; full operating temperature range is -40°C to +105°C ambient temp with appropriate power derating. Specifications subject to change without notice.

Parameter	Module	Min.	Typ.	Max.	Units	Notes & Conditions
ABSOLUTE MAXIMUM RATINGS						
Input Voltage						
Non-Operating	All	0		7	V	Continuous
Operating	All			6	V	Continuous
Operating Temperature	All	-40		105	°C	
Storage Temperature	All	-55		125	°C	
Voltage at ON/OFF input pin	All	-3		6	V	
RECOMMENDED OPERATING CONDITIONS						
Input Voltage Range	All	2.4		6	V	
Input Fuse Rating	All			20	A	Fast blow external fuse recommended
External Input Capacitance	All	100			µF	ESR<1.5Ω
Output Voltage	All	0.75		3.6	V	
Output Current	All	0		10	A	
INPUT CHARACTERISTICS						
Input Under-Voltage Lockout						
Turn-On Voltage Threshold	All	2.07	2.21	2.35	V	
Turn-Off Voltage Threshold	All	1.92	2.01	2.10	V	
Lockout Hysteresis	All		0.2		V	
Maximum Input Current	0.75V			4.36	A	2.4V _{in} ; 100% load
"	2.5V			8.15	A	3.6V _{in} ; 100% load
"	3.3V			10.16	A	3.6V _{in} ; 100% load
No-Load Input Current	0.75V		106		mA	5V _{in}
"	2.5V		119		mA	"
"	3.3V		124		mA	"
Disabled Input Current	All		10		mA	
Inrush Current Transient Rating	All			0.1	A ² s	With min. output capacitance
Input Filter Capacitor Value	All		30		µF	
Input Reflected-Ripple Current (pk-pk\RMS)	0.75V		37\11		mA	5V _{in} ; 100% load
"	2.5V		70\21		mA	
"	3.3V		60\18		mA	
OUTPUT CHARACTERISTICS						
Output Voltage Set Point	0.75V	0.745	0.750	0.755	V	5V _{in} 50% load
Output Voltage Range	All	0.75		3.60	V	
Operating Output Current Range	All	0		10	A	
Output Voltage Regulation						
Over Line	All			0.5	%	With sense pin
Over Load	All			0.7	%	"
Over Temperature	All			1	%	"
Total Output Voltage Range	All			3	%	With sense pin, over sample, line, load, temp. & life
Output Voltage Ripple and Noise (pk-pk\RMS)	0.75V		22.4\6.0		mV	Full load; 20MHz bandwidth; Figures 13 & 16
"	2.5V		33.2\10.3		mV	"
"	3.3V		30.8\8.5		mV	"
Output DC Over Current Shutdown	All	12	19	24	A	
External Output Capacitance	All	100		5000	µF	>0.5mohm
DYNAMIC CHARACTERISTICS						
Input Voltage Ripple Rejection	All		45		dB	120Hz; Figure 18
Output Voltage during Current Transient						
For a Step Change in Output Current (0.1A/µs)	All		100		mV	50%-75%-50% lout max; 100µF; Figure 11
For a Step Change in Output Current (3A/µs)	All		100		mV	50%-75%-50% lout max; 470µF; Figure 11
Settling Time	All		100		µs	To within 1.5% V _{out} nom.; Figures 11 & 12
Turn on Transient						Figures 9 & 10
Inhibit Time	All	2		6	ms	Resistive load
Rise Time	All	2		6	ms	"
Output Voltage Overshoot	All			0	V	"
TEMP LIMITS FOR POWER DERATING						
Semiconductor Junction Temperature	All			125	°C	Package rated to 150°C; Figures 3 - 8
Board Temperature	All			125	°C	UL rated max operating temp 130°C



Technical Specification

Input: 2.4 - 6.0V
Outputs: 0.75 - 3.6V
Current: 10A
Package: SMT

ELECTRICAL CHARACTERISTICS (continued) - NQ04W33SKA10 Series

Parameter	Module	Min.	Typ.	Max.	Units	Notes & Conditions
EFFICIENCY						
100% Load	0.75V		83.0		%	Figures 1 & 2
"	1.8V		91.0		%	"
"	3.3V		95.0		%	"
50% Load	0.75V		84.0		%	"
"	1.8V		91.0		%	"
"	3.3V		95.0		%	"
FEATURE CHARACTERISTICS						
Switching Frequency	All	275	300	325	kHz	
Open Logic (O) ON/OFF Control						Figure A
Off-State Voltage	All	1.5		6.5	V	
On-State Voltage	All	-3		0.6	V	
Input Resistance	All		20		kΩ	
Positive Logic (P) ON/OFF Control						Open collector/drain input; Figure A
Logic Low Voltage Range	All	-0.2		1	V	
Logic High Voltage Range (internal pullup)	All	2.2			V	
Logic Low sink current	All		50		μA	
Logic High sink current (leakage)	All			100	μA	
Output Voltage Trim Range	All	0.75		3.6	V	Measured Vout+ to common pins; Table 1
Output Over-Voltage Protection	All	3.9	4.2	4.6	V	Over full temp range
Over-Temperature Shutdown	All		128		°C	Average PCB Temperature
Over-Temperature Shutdown Restart Hysteresis	All		10		°C	
RELIABILITY CHARACTERISTICS						
Calculated MTBF (Telcordia)	All		15.6		10 ⁶ Hrs.	TR-NWT-000332; 100% load, 200LFM, 40°C T _a
Calculated MTBF (MIL-217)	All		15.6		10 ⁶ Hrs.	MIL-HDBK-217F; 100% load, 200LFM, 40°C T _a
Field Demonstrated MTBF	All				10 ⁶ Hrs.	See our website for details

STANDARDS COMPLIANCE

Parameter	Notes
STANDARDS COMPLIANCE	
UL/cUL 60950-1	File # E194341
EN60950-1	Certified by TÜV
72/23/EEC	
93/68/EEC	
Needle Flame Test (IEC 695-2-2)	Test on entire assembly; board & plastic components UL94V-0 compliant
IEC 61000-4-2	ESD test, 8kV - NP, 15kV air - NP (Normal Performance)
GR-1089-CORE	Section 7 - electrical safety, Section 9 - bonding/grounding
Telcordia (Bellcore) GR-513	

- An external input fuse must always be used to meet these safety requirements. Contact SynQor for official safety certificates on new releases or download from the SynQor website.

QUALIFICATION TESTING

Parameter	# Units	Test Conditions
QUALIFICATION TESTING		
Life Test	32	95% rated V _{in} and load, units at derating point, 1000 hours
Vibration	5	10-55Hz sweep, 0.060" total excursion, 1 min./sweep, 120 sweeps for 3 axis
Mechanical Shock	5	100g minimum, 2 drops in x and y axis, 1 drop in z axis
Temperature Cycling	10	-40°C to 100°C, unit temp. ramp 15°C/min., 500 cycles
Power/Thermal Cycling	5	Toperating = min to max, V _{in} = min to max, full load, 100 cycles
Design Marginality	5	T _{min} -10°C to T _{max} +10°C, 5°C steps, V _{in} = min to max, 0-105% load
Humidity	5	85°C, 85% RH, 1000 hours, continuous V _{in} applied except 5min./day
Solderability	15 pins	MIL-STD-883, method 2003

- Extensive characterization testing of all SynQor products and manufacturing processes is performed to ensure that we supply robust, reliable product. Contact the factory for official product family qualification documents.

OPTIONS

SynQor provides various options for Packaging, Enable Logic, and Feature Set for this family of DC/DC converters. Please consult the last page for information on available options.

PATENTS

SynQor is protected under various patents. Please consult the last page for further details.

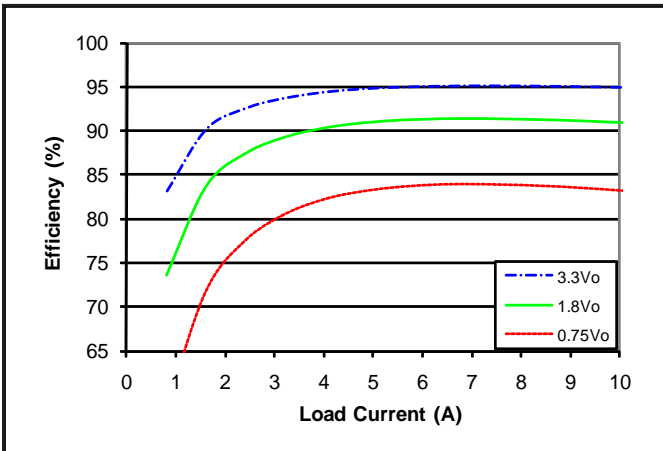

Figure 1: Efficiency at nominal output voltage vs. load current for nominal input voltage at 25°C.

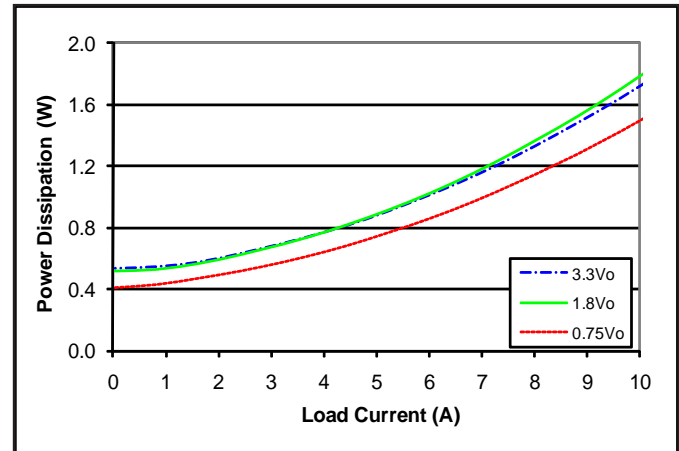

Figure 2: Power dissipation at nominal output voltage vs. load current for nominal input voltage at 25°C.

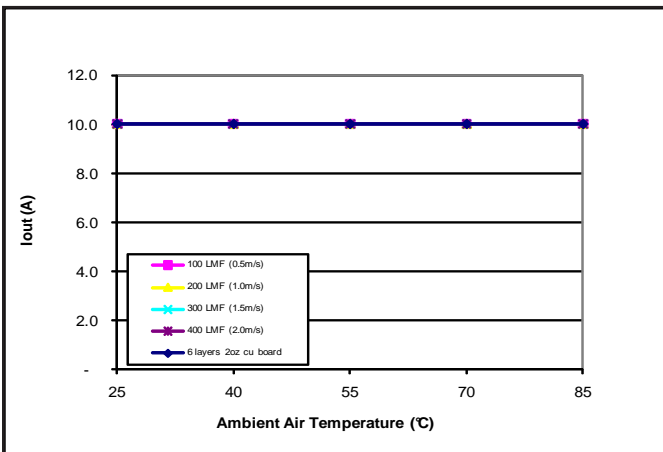

Figure 3: Maximum output power derating curves for 0.75Vo, 1.2Vo units under various thermal conditions and nominal input voltage. See Thermal Considerations section for more details.

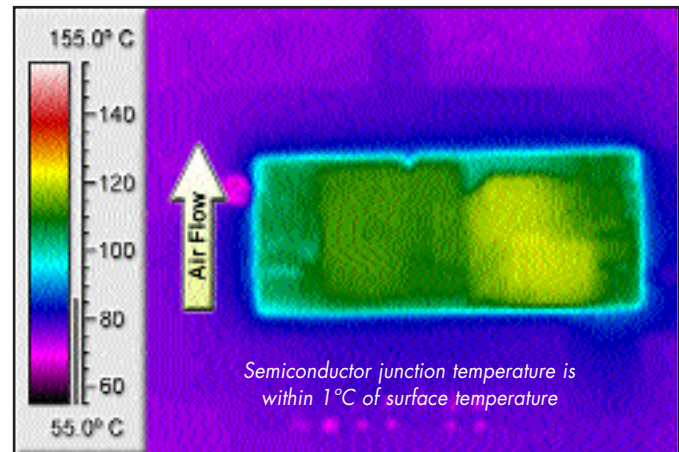

Figure 4: Thermal plot of 0.75Vo, 1.2Vo converters at nominal Vin and 10 amp load current mounted on a 85°C, 6-Layer, 2 oz. copper board (typical installation).

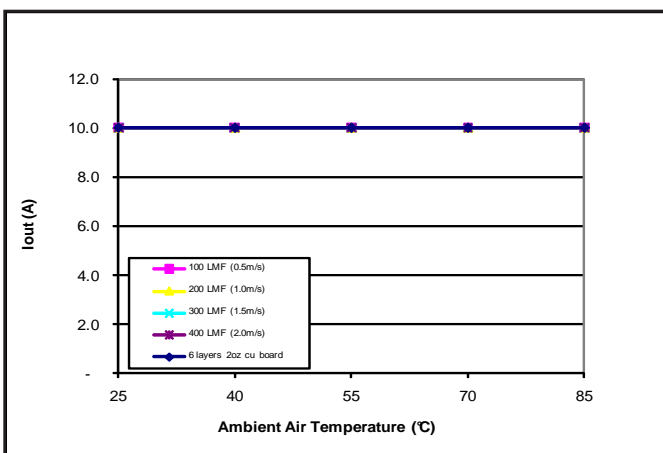

Figure 5: Maximum output power derating curves for 1.5Vo, 1.8Vo units under various thermal conditions and nominal input voltage. See Thermal Considerations section for more details.

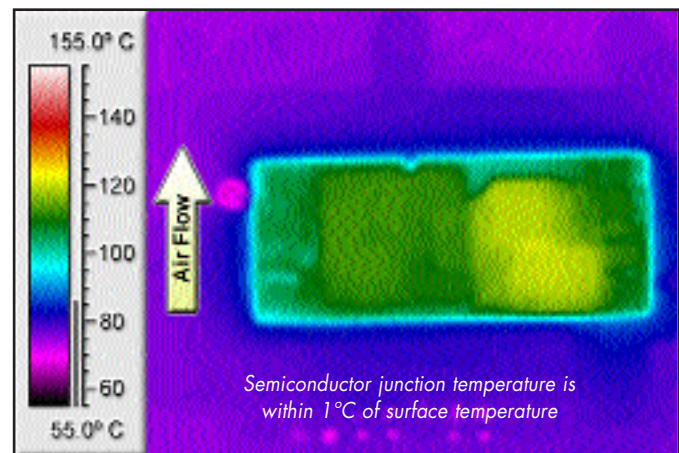

Figure 6: Thermal plot of 1.5Vo, 1.8Vo converters at nominal Vin and 10 amp load current mounted on a 85°C, 6-Layer, 2 oz. copper board (typical installation).

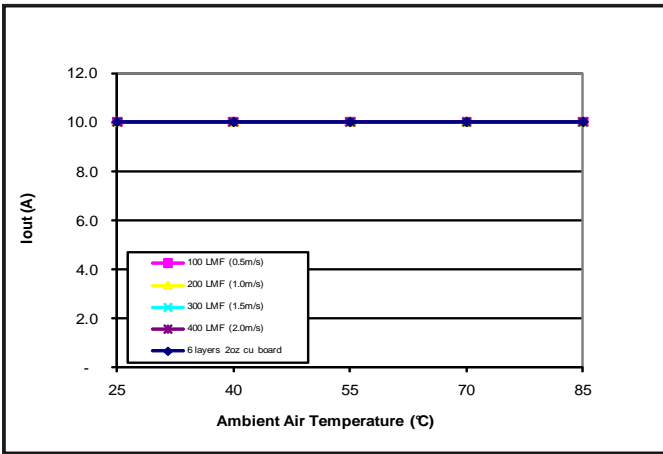

Figure 7: Maximum output power derating curves for 2.5Vo, 3.3Vo units under various thermal conditions and nominal input voltage. See Thermal Considerations section for more details.

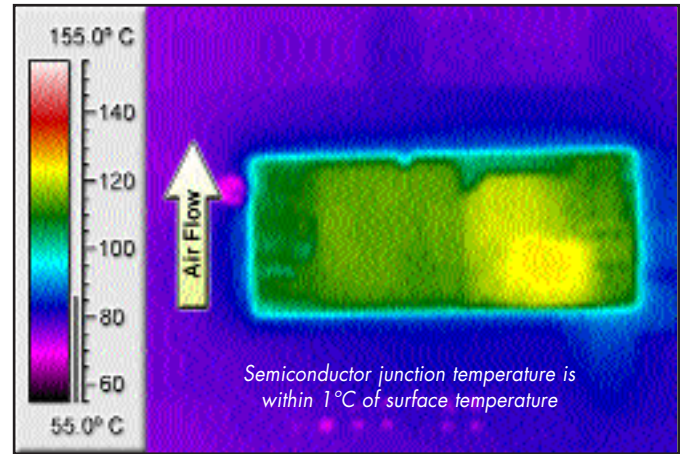

Figure 8: Thermal plot of 2.5Vo, 3.3Vo converters at nominal Vin and 10 amp load current mounted on a 85°C, 6-Layer, 2 oz. copper board (typical installation).

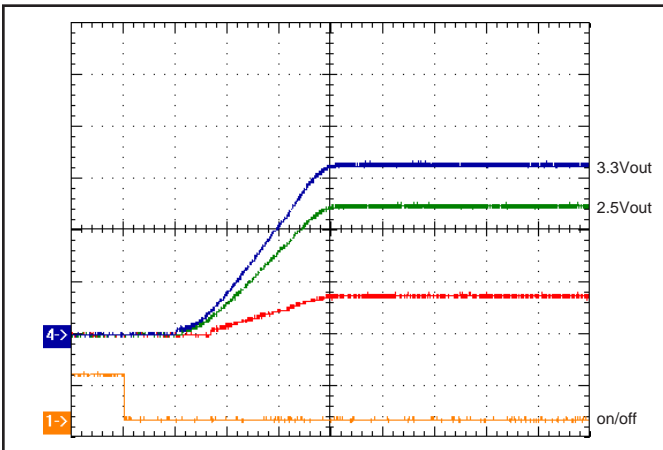

Figure 9: Turn-on transient at full load (resistive load) (2 ms/div).
 Ch 1: ON/OFF input (5V/div)
 Ch 2-4: Vout (1V/div)

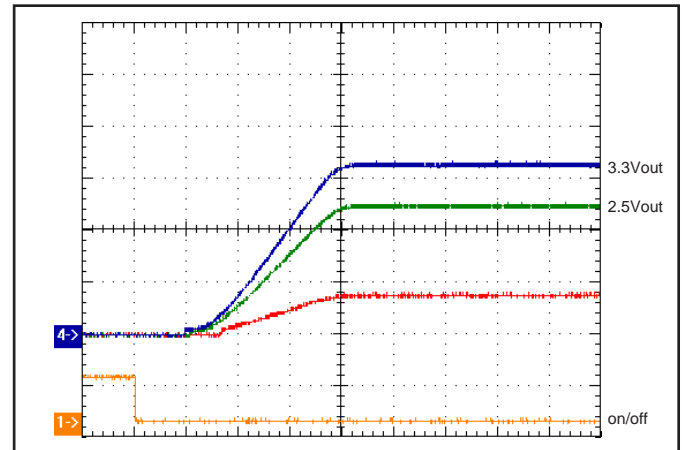

Figure 10: Turn-on transient at zero load (2 ms/div).
 Ch 1: ON/OFF input (5V/div)
 Ch 2-4: Vout (1V/div)

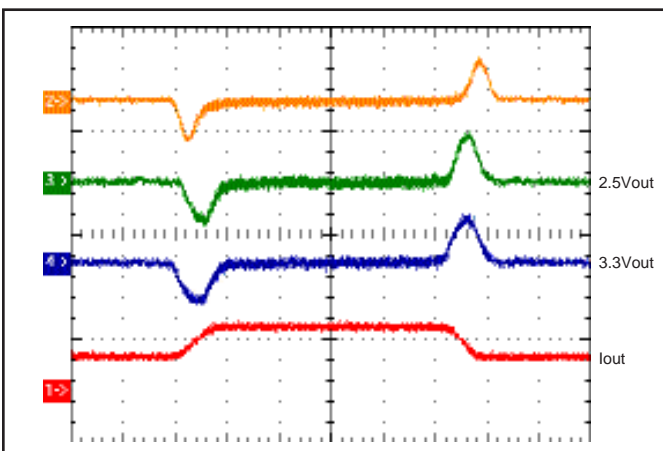

Figure 11: Output voltage response for 0.75V, 2.5V, 3.3V units to step-change in load current (50-75-50% of Iout max; di/dt=0.1A/μs). Load cap: 100μF, 100mΩ ESR tant, 10μF cer. Ch 1: Iout (10A/div), Ch 2-4: Vout

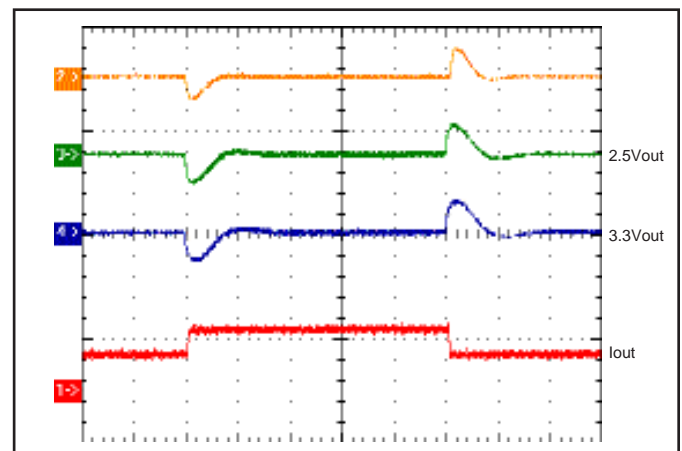

Figure 12: Output voltage response for 0.75V, 2.5V, 3.3V units to step-change in load current (50-75-50% of Iout max; di/dt=3A/μs). Load cap: 470μF, 100mΩ ESR tant, 10μF cer. Ch 1: Iout (10A/div), Ch 2-4: Vout (200mV/div).

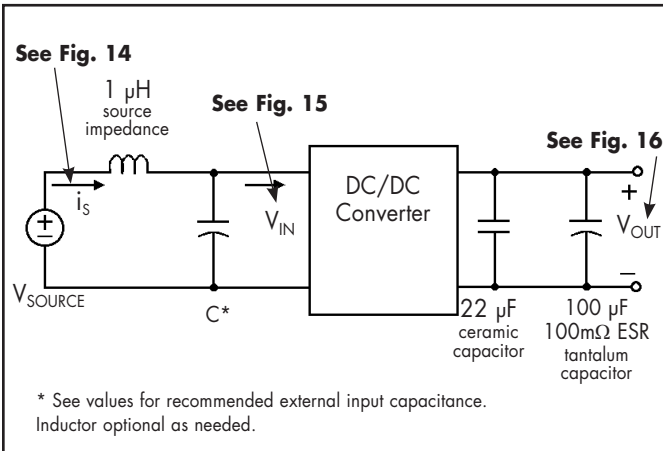

Figure 13: Test set-up diagram showing measurement points for Input Reflected Ripple Current (Figure 14), Input Terminal Ripple Voltage (Figure 15), and Output Voltage Ripple (Figure 16).

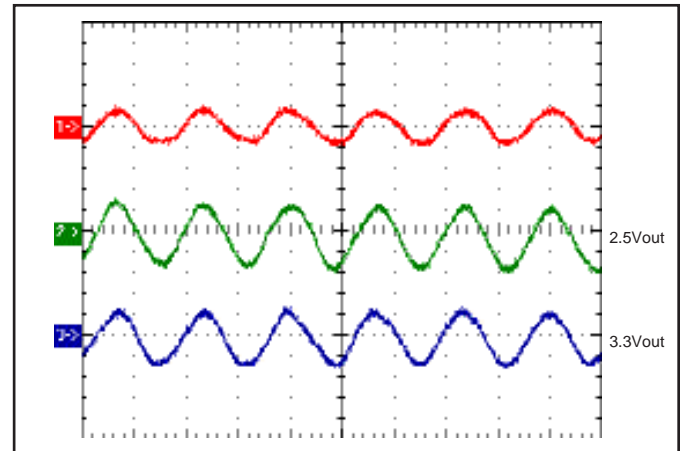

Figure 14: Input Reflected Ripple Current, i_s , through a 1 μ H source inductor at nominal input voltage and rated load current (100 mA/div). See Figure 13.

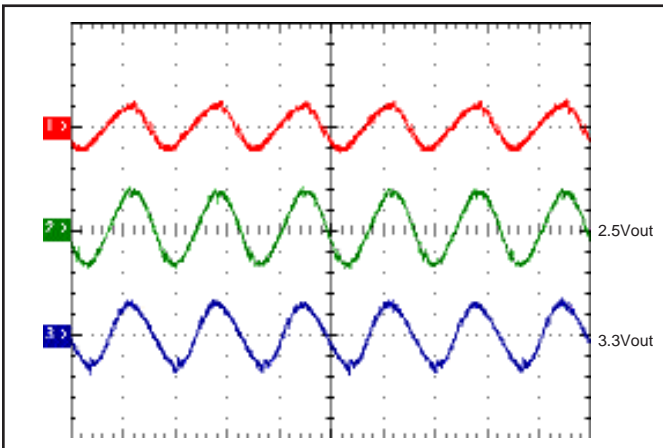

Figure 15: Input Terminal Ripple Voltage at nominal input voltage and rated load current (200 mV/div). Load capacitance: 22 μ F ceramic cap and 100 μ F tantalum cap. Bandwidth: 20 MHz. See Figure 13.

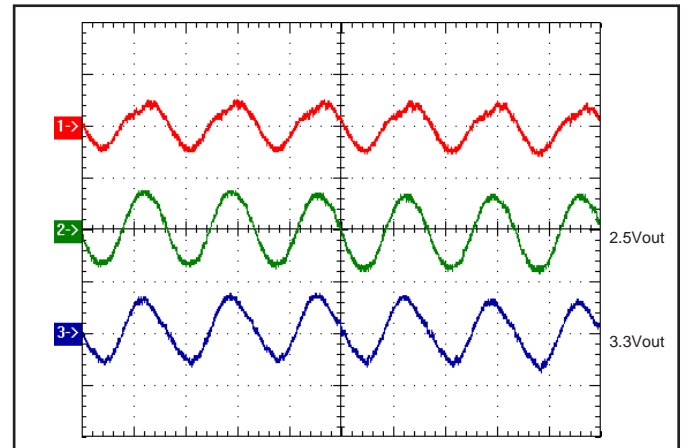

Figure 16: Output Voltage Ripple at nominal input voltage and rated load current (20 mV/div). Load capacitance: 22 μ F ceramic cap and 100 μ F tantalum cap. Bandwidth: 20 MHz. See Figure 13.

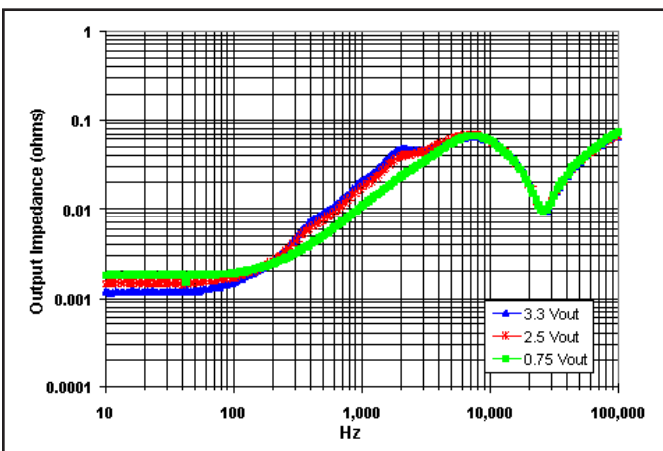

Figure 17: Magnitude of incremental output impedance ($Z_{out} = v_{out} / i_{out}$) for nominal input voltage at full rated power with 100 μ F tantalum output capacitor.

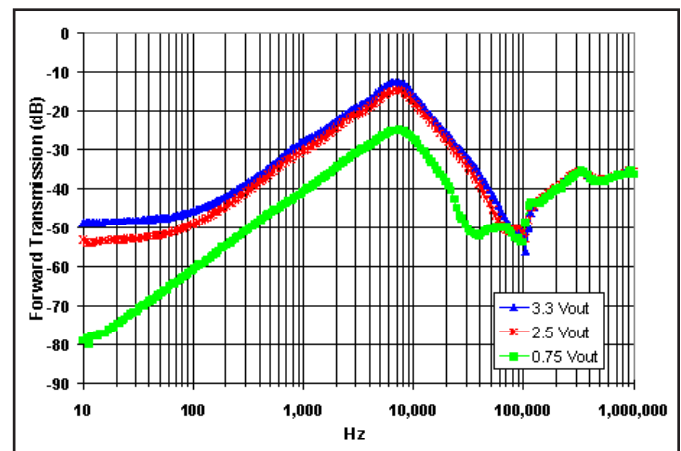

Figure 18: Magnitude of incremental forward transmission ($FT = v_{out} / v_{in}$) for nominal input voltage at full rated power with 100 μ F tantalum output capacitor.

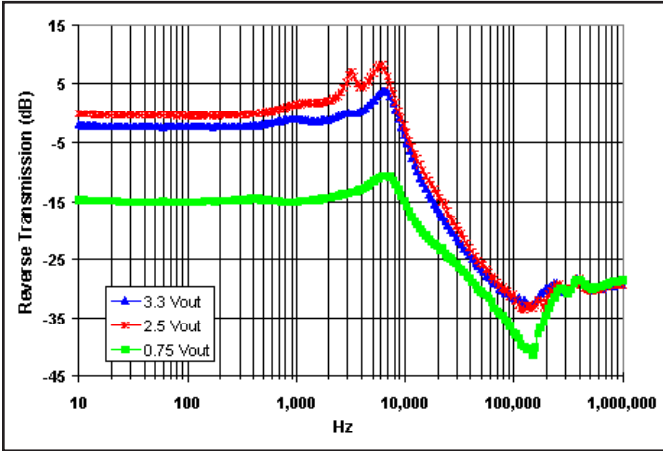

Figure 19: Magnitude of incremental reverse transmission ($RT = i_{in}/i_{out}$) for nominal input voltage at full rated power with $100\mu\text{F}$ tantalum output capacitor.

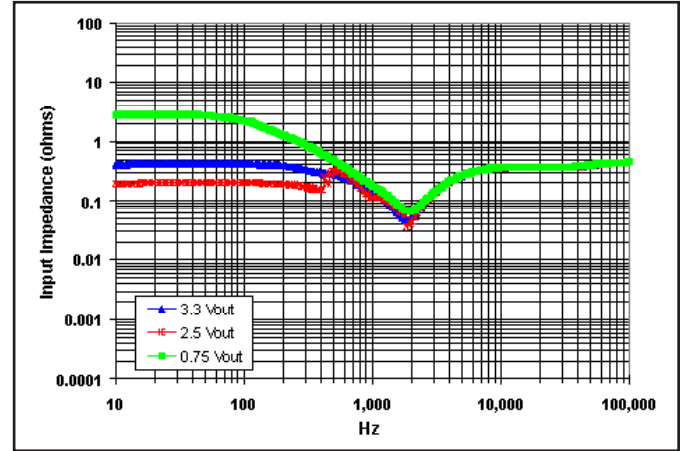

Figure 20: Magnitude of incremental input impedance ($Z_{in} = v_{in}/i_{in}$) for nominal input voltage at full rated power with $100\mu\text{F}$ tantalum output capacitor.

BASIC OPERATION AND FEATURES

The NiQor series non-isolated converter uses a buck-converter that keeps the output voltage constant over variations in line, load, and temperature. The NiQor modules employ synchronous rectification for very high efficiency.

Dissipation throughout the converter is so low that it does not require a heatsink or metal baseplate for operation. The NiQor converter can thus be built more simply and reliably using high yield surface mount techniques on a single PCB substrate.

The NiQor series of SIPs and SMT converters uses the established industry standard footprint and pin-out configurations.

CONTROL FEATURES

REMOTE ON/OFF: The ON/OFF input permits the user to control when the converter is on or off. There are currently two options available for the ON/OFF input described in the table below. Others may become available if demand exists.

Option	Description	Pin-Open Float Voltage	Pin-Open Converter State	Pin Action
P Logic	Positive/Open	5V	On	Pull Low=Off
O Logic	Negative/Open	0V	On	Pull High=Off

OUTPUT VOLTAGE TRIM: The TRIM input permits the user to adjust the output voltage according to the trim range specifications by using an external resistor. If the TRIM feature is not being used, leave the TRIM pin disconnected.

TRIM-UP: To increase the output voltage from the nominal setpoint of 0.7525V using an external resistor, connect the resistor $R_{trim-up}$ between the TRIM and the Ground pin according to the diagram below.

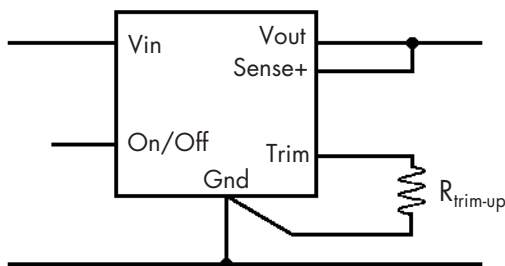

For a desired increase of the nominal output voltage, the value of the resistor should be:

$$R_{trim-up} = \frac{21070}{V_{DES} - 0.7525} - 5110 \ (\Omega)$$

or

$$V_{OUT} = 0.7525 + \frac{21070}{R_{trim-up} + 5110} \ (\Omega)$$

where V_{DES} = Desired Output Voltage

To maintain the accuracy of the output voltage over load current, it is vital that any trim-up resistor be terminated directly to the converter's ground foot, not at the connection to the load. A separate Kelvin connection to the PCB pad for the ground foot is optimal. Trim-down resistors should be terminated at the converter's Sense+ pin.

We do not recommend bypassing the trim pin directly to ground with a capacitor. The voltage gain from the trim pin to output is rather large, 15:1. Ground bounce through a bypass capacitor could introduce significant noise to the converter's control circuit.

PROTECTION FEATURES

Input Under-Voltage Lockout: The converter is designed to turn off when the input voltage is too low, helping avoid an input system instability problem, described in more detail in the application note titled "Input System Instability". The lockout circuitry is a comparator with DC hysteresis. When the input voltage is rising, it must exceed the typical Turn-On Voltage Threshold value (listed on the specification page) before the converter will turn on. Once the converter is on, the input voltage must fall below the typical Turn-Off Voltage Threshold value before the converter will turn off.

Output Current Limiting: To provide protection in an output over load fault condition, the unit is equipped with internal over-current protection. When the over-current protection is triggered, the unit enters hiccup mode. The units operate normally once the fault condition is removed.

Internal Over-Voltage Protection: To fully protect from excessive output voltage, the NQ04 series contains an Output Over-Voltage Shutdown circuitry.

This OVP is independent of the trimmed setpoint. As such, the converter's load is protected from faults in the external trim circuitry (such as a trim pin shorted to ground). Since the setpoint of this OVP does not track trim, it is set at 4.2V, in the wide-trim W33 model.

The shutdown point is fixed on standard option. SKA also offers adjustable OVP set point. For more detailed information contact SynQor technical support.

Over-Temperature Shutdown: A temperature sensor on the converter senses the average temperature of the module. The thermal shutdown circuit is designed to turn the converter off when the temperature at the sensed location reaches the Over-Temperature Shutdown value. It will allow the converter to turn on again when the temperature of the sensed location falls by the amount of the Over-Temperature Shutdown Restart Hysteresis value.

APPLICATION CONSIDERATIONS

Input Filtering/Capacitance/Damping: The filter circuit of Figure E is often added to the converter's input to prevent switching noise from reaching the input voltage bus.

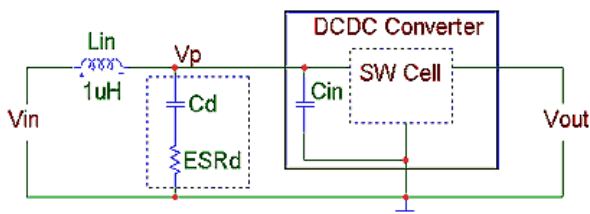

Figure E: NQ04 converter with Input Filter

In the SKA10 (surface mount) converters $C_{in} = 30\mu\text{F}$ of high quality ceramic capacitors. With L_{in} of $1\mu\text{H}$, C_d should be $100\text{-}200\mu\text{F}$ and R_d should be $0.1\text{-}0.2\Omega$, in most applications. For more information on designing the input filter and choosing proper values, contact SynQor technical support.

Adding significant external pure ceramic capacitance directly across the converter's input pins is not recommended. Parasitic inductance associated with the input pin geometry and PCB traces can create a high-Q CLC circuit with any external capacitors. Just a few nano-Henries of parasitic inductance can create a resonance (or an overtone) near the converter's switching frequency. C_{in} has a reactance of $10\text{-}20\text{m}\Omega$ at the 300kHz switching frequency. To avoid this high-frequency resonance, any external input filter should exhibit a net source impedance of at least $20\text{m}\Omega$ resistive through this frequency range. This requirement is easily met with the damping elements discussed above. Adding a small amount (a few μF) of high-frequency external ceramic will not violate it.

If using converters at higher powers, consider the ripple current rating of C_d . Contact SynQor technical support for details.

Output Capacitance: It is recommended to add at least $100\mu\text{F}$ of capacitance, with an ESR in the 0.1Ω range, to the

output of the SKA10 series of converters. The VKA10 series has this capacitance included internally. In many applications, however, additional external output capacitance is required to reduce the response to load transients to an allowable level.

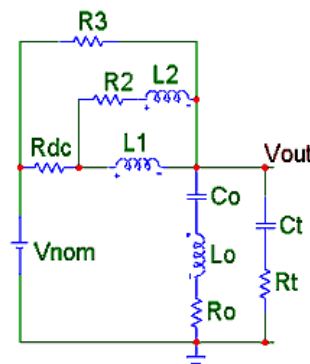

Figure F: NQ04 Passive Output Model

its resistance R_t . In the VMA10 family, that capacitor is again included in the converter.

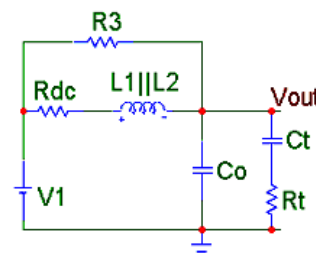

Figure G: Simplified NQ04 Output Model

If the dynamic characteristics of the load are known, any standard simulator can use these models to predict the in-circuit transient response.

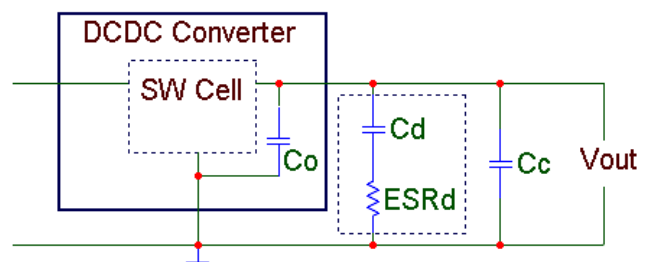

Figure H: Converter with Additional Output Capacitance

For minimal overshoot upon recovery, C_d should be related to the minimum in-circuit net ESR.

$$C_d > \frac{\text{parallel } (L_1, L_2)}{\text{ESR}_{\text{min}}^2}$$

For more detailed derivations of these values contact SynQor technical support.

Thermal Performance (SKA10): While impossible to be exact, a simplified thermal model for the mounted converter is detailed below.

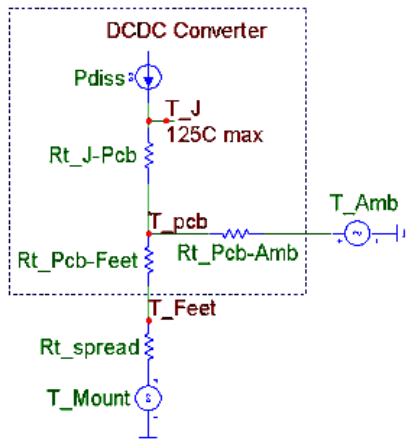

Figure 1: Thermal Model for NQ04 Surface Mount

- R_{t_J-Pcb} models the conduction of heat from the converter's hottest junction to the converter's PCB at large. It is about $3^{\circ}\text{C}/\text{W}$ for converters running at higher output voltage, and about $4^{\circ}\text{C}/\text{W}$ for lower voltage converters.
- $R_{t_Pcb-Amb}$ models the power dissipation from converter PCB to the air stream. It ranges from about $15^{\circ}\text{C}/\text{W}$ at 400LFM to about $25^{\circ}\text{C}/\text{W}$ 100LFM.
- $R_{t_Pcb-Feet}$ expresses the thermal path from the converter's PCB through its mounting feet; it is about $3^{\circ}\text{C}/\text{W}$.
- R_{t_spread} models the heat spreading on the PCB to which the converter is mounted and is largely dependent upon the construction and layout of that PCB.
- T_{mount} is the temperature of that PCB in the greater vicinity of the converter.

As is evident, the values for R_{t_spread} and T_{mount} will have great effect upon the thermal operation of the converter. With $R_{t_Pcb-Amb}$ being 5 to 8 times as large as $R_{t_Pcb-Feet}$, in most applications these converters will be predominantly cooled via thermal conduction through their feet. Airflow and T_{Amb} will have only a minimal cooling effect.

- R_{t_spread} should be minimized. Attach the converter to large copper planes, on multiple layers, with multiple vias near the mounting feet.
- T_{mount} should also be minimized. Place the converter far enough away from other sources of heat on the PCB so that it is as cool as practical.
- If operation near derating limits is even suspected, thermal performance should be verified with the unit mounted in its intended manner and powered in circuit with all neighboring circuitry active. Attach a thermocouple to the converter's hotspot as shown in Figures 4, 6, and 8 in the Performance Curves section.

SURFACE MOUNT INFORMATION

PCB Layout Considerations: SynQor recommends that the customer use a non-solder mask defined pad design. The minimum recommended pad size is $0.074'' \times 0.122''$ ($1.88\text{mm} \times 3.1\text{mm}$) and the maximum pad size is $0.095'' \times 0.140''$ ($2.41\text{mm} \times 3.56\text{mm}$), see the mechanical diagram on page 2. Interconnection to internal power planes is typically required. This can be accomplished by placing a number of vias between the SMT pad and the relevant plane. The number and location of the vias should be determined based on electrical resistance, current and thermal requirements. "Via-in-pad" design should be avoided in the SMT pads. Solder mask should be used to eliminate solder wicking into the vias.

Pick and Place: The NiQor surface mount modules are designed for automated assembly using standard SMT pick and place equipment. The modules have a centrally located inductor component with a flat surface area to be used for component pick-up. The units use open frame construction and have a low mass that is within the capability of standard pick and place equipment. Those modules however have a larger mass than most conventional SMT components and so variables such as nozzle size, tip style, handling speed, and placement pressure should be optimized for best results. A conformal tipped placement nozzle design is recommended. Coplanarity of better than $0.004''$ (0.1mm) is achieved through the SMT NiQor's terminal design.

Reflow Soldering Guidelines: Figure J shows a typical reflow profile for a eutectic solder process. Due to variations in customer applications, materials and processes, it is not feasible for SynQor to recommend a specific reflow profile. The customer should use this profile as a guideline only. Since the NiQor surface mount modules have a larger thermal mass and lower thermal resistance than standard SMT components, it may be necessary to optimize the solder reflow profile based on limitations of the other components on the customer board. Sufficient reflow time must be allowed to fuse the plating on the connection to ensure a reliable solder joint. The solder reflow profile should be confirmed by accurately measuring the SMT interconnect leads. Maximum case temperature of 260°C (exposure for 5 seconds or less) is not exceeded for the NiQor units.

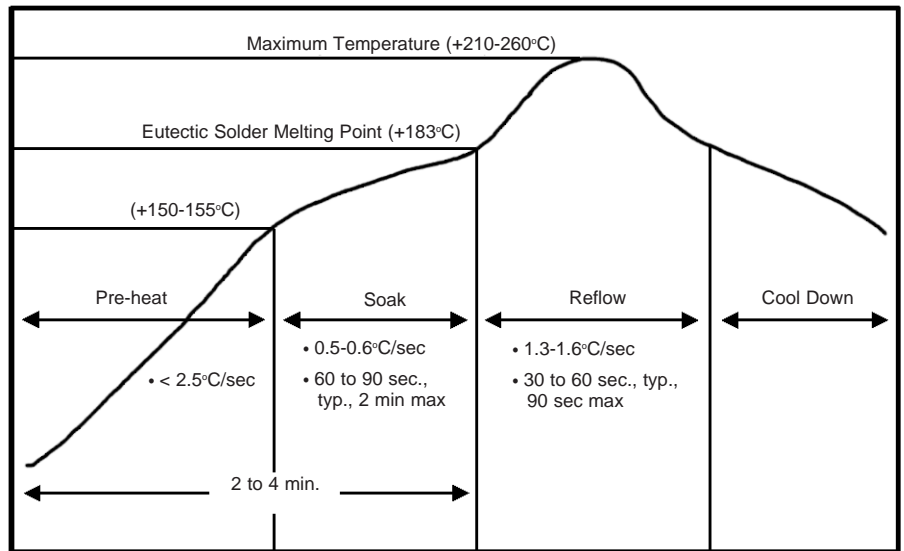

Figure J: Typical Eutectic (96.5Sn/3.0Ag/0.5Cu) Solder Profile

Moisture Sensitivity: The NiQor surface mount modules have an MSL rating 1 per IPC/JEDEC J-STD-033A.

Cleaning and Drying: When possible, a no-clean solder paste system should be used to solder the NiQor SMT units to their application board. The modules are suitable for aqueous washing, however, the user must ensure sufficient drying to remove all water from the converter before powering up. Inadequate cleaning and drying can affect the reliability of the converter and the testing of the final assembly.

RoHS Compliance: The EU led RoHS (Restriction of Hazardous Substances) Directive bans the use of Lead, Cadmium, Hexavalent Chromium, Mercury, Polybrominated Biphenyls (PBB), and Polybrominated Diphenyl Ether (PBDE) in Electrical and Electronic Equipment. This SynQor product is 6/6 RoHS compliant. For more information please refer to SynQor's RoHS addendum available at our [RoHS Compliance / Lead Free Initiative](#) web page or e-mail us at rohs@synqor.com.



Technical Specification

Input: 2.4 - 6.0V
Outputs: 0.75 - 3.6V
Current: 10A
Package: SMT

PART NUMBERING SYSTEM

The part numbering system for SynQor's NiQor DC/DC converters follows the format shown in the example below.

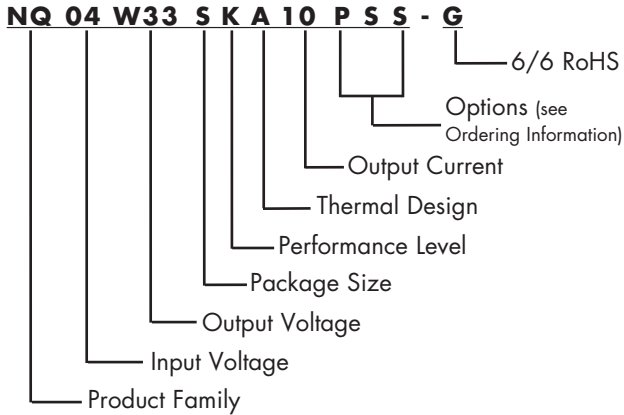

The first 12 characters comprise the base part number and the last 3 characters indicate available options. A "-G" suffix indicates the product is 6/6 RoHS compliant.

Application Notes

A variety of application notes and technical white papers can be downloaded in pdf format from our website.

ORDERING INFORMATION

The tables below show the valid model numbers and ordering options for converters in this product family. When ordering SynQor converters, please ensure that you use the complete 15 character part number consisting of the 12 character base part number and the additional 3 characters for options. A "-G" suffix indicates the product is 6/6 RoHS compliant.

Model Number	Input Voltage	Output Voltage	Max Output Current
NQ04W33SKA10xyz-G	2.4 - 6.0V	0.75-3.6V	10A

The following option choices must be included in place of the x y z spaces in the model numbers listed above.

Options Description: x y z		
Enable Logic	Pin Style	Feature Set
P - Pos/Open O - Neg/Open	S - Standard	S - Sense N - None

PATENTS

SynQor holds the following U.S. patents, one or more of which apply to each product listed in this document. Additional patent applications may be pending or filed in the future.

5,999,417	6,222,742	6,545,890	6,577,109	6,594,159
6,731,520	6,894,468	6,896,526	6,927,987	7,050,309
7,072,190	7,085,146	7,119,524	7,269,034	7,272,021
7,272,023	7,558,083	7,564,702	7,765,687	7,787,261

Contact SynQor for further information:

Phone: 978-849-0600
Toll Free: 888-567-9596
Fax: 978-849-0602
E-mail: power@synqor.com
Web: www.synqor.com
Address: 155 Swanson Road
 Boxborough, MA 01719
 USA

Warranty

SynQor offers a three (3) year limited warranty. Complete warranty information is listed on our website or is available upon request from SynQor.

Information furnished by SynQor is believed to be accurate and reliable. However, no responsibility is assumed by SynQor for its use, nor for any infringements of patents or other rights of third parties which may result from its use. No license is granted by implication or otherwise under any patent or patent rights of SynQor.