



RF Power LDMOS Transistors

High Ruggedness N-Channel Enhancement-Mode Lateral MOSFETs

Designed for mobile two-way radio applications with frequencies from 136 to 520 MHz. The high gain, ruggedness and broadband performance of these devices make them ideal for large-signal, common source amplifier applications in mobile radio equipment.

Typical Performance: (13.6 Vdc, T_A = 25°C, CW)

Frequency (MHz)	G _{ps} (dB)	η _D (%)	P _{1dB} (W)
380-450 (1,3)	18.3	64.1	31
450-520 (2,3)	17.7	62.0	31
520 (4)	17.7	71.4	33

Load Mismatch/Ruggedness

Frequency (MHz)	Signal Type	VSWR	P _{out} (W)	Test Voltage	Result
520 (4)	CW	>65:1 at all Phase Angles	47 (3 dB Overdrive)	17	No Device Degradation

1. Measured in 380-450 MHz UHF wideband reference circuit.
2. Measured in 450-520 MHz UHF wideband reference circuit.
3. The values shown are the minimum measured performance numbers across the indicated frequency range.
4. Measured in 520 MHz narrowband test circuit.

Features

- Characterized for Operation from 136 to 520 MHz
- Unmatched Input and Output Allowing Wide Frequency Range Utilization
- Integrated ESD Protection
- Integrated Stability Enhancements
- Wideband — Full Power Across the Band:
 - 136-174 MHz
 - 380-450 MHz
 - 450-520 MHz
- 225°C Capable Plastic Package
- Exceptional Thermal Performance
- High Linearity for: TETRA, SSB, LTE
- Cost-effective Over-molded Plastic Packaging
- In Tape and Reel. R1 Suffix = 500 Units, 24 mm Tape Width, 13 inch Reel.

Typical Applications

- Output Stage VHF Band Mobile Radio
- Output Stage UHF Band Mobile Radio

AFT05MS031NR1
AFT05MS031GNR1

136-520 MHz, 31 W, 13.6 V
WIDEBAND
RF POWER LDMOS TRANSISTORS

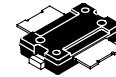

TO-270-2
PLASTIC
AFT05MS031NR1

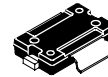

TO-270-2 GULL
PLASTIC
AFT05MS031GNR1

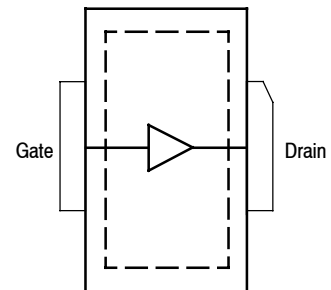

(Top View)

Note: The backside of the package is the source terminal for the transistor.

Figure 1. Pin Connections

Table 1. Maximum Ratings

Rating	Symbol	Value	Unit
Drain-Source Voltage	V_{DSS}	-0.5, +40	Vdc
Gate-Source Voltage	V_{GS}	-6.0, +12	Vdc
Operating Voltage	V_{DD}	17, +0	Vdc
Storage Temperature Range	T_{stg}	-65 to +150	°C
Total Device Dissipation @ $T_C = 25^\circ\text{C}$ Derate above 25°C	P_D	294 1.47	W W/°C
Operating Junction Temperature (1,2)	T_J	225	°C

Table 2. Thermal Characteristics

Characteristic	Symbol	Value (2,3)	Unit
Thermal Resistance, Junction to Case Case Temperature 79°C , 31 W CW, 13.6 Vdc, $I_{DQ} = 10\text{ mA}$, 520 MHz	$R_{\theta JC}$	0.67	°C/W

Table 3. ESD Protection Characteristics

Test Methodology	Class
Human Body Model (per JESD22-A114)	2, passes 2500 V
Machine Model (per EIA/JESD22-A115)	A, passes 100 V
Charge Device Model (per JESD22-C101)	IV, passes 2000 V

Table 4. Moisture Sensitivity Level

Test Methodology	Rating	Package Peak Temperature	Unit
Per JESD22-A113, IPC/JEDEC J-STD-020	3	260	°C

Table 5. Electrical Characteristics ($T_A = 25^\circ\text{C}$ unless otherwise noted)

Characteristic	Symbol	Min	Typ	Max	Unit
----------------	--------	-----	-----	-----	------

Off Characteristics

Zero Gate Voltage Drain Leakage Current ($V_{DS} = 40\text{ Vdc}$, $V_{GS} = 0\text{ Vdc}$)	I_{DSS}	—	—	2	μAdc
Zero Gate Voltage Drain Leakage Current ($V_{DS} = 13.6\text{ Vdc}$, $V_{GS} = 0\text{ Vdc}$)	I_{DSS}	—	—	1	μAdc
Gate-Source Leakage Current ($V_{GS} = 5\text{ Vdc}$, $V_{DS} = 0\text{ Vdc}$)	I_{GSS}	—	—	600	nAdc

On Characteristics

Gate Threshold Voltage ($V_{DS} = 10\text{ Vdc}$, $I_D = 115\ \mu\text{Adc}$)	$V_{GS(th)}$	1.6	2.1	2.6	Vdc
Drain-Source On-Voltage ($V_{GS} = 10\text{ Vdc}$, $I_D = 1.2\text{ Adc}$)	$V_{DS(on)}$	—	0.13	—	Vdc
Forward Transconductance ($V_{GS} = 10\text{ Vdc}$, $I_D = 7.5\text{ Adc}$)	g_{fs}	—	5.8	—	S

1. Continuous use at maximum temperature will affect MTTF.
2. MTTF calculator available at <http://www.freescale.com/rf>. Select Software & Tools/Development Tools/Calculators to access MTTF calculators by product.
3. Refer to AN1955, *Thermal Measurement Methodology of RF Power Amplifiers*. Go to <http://www.freescale.com/rf>. Select Documentation/Application Notes - AN1955.

(continued)

Table 5. Electrical Characteristics ($T_A = 25^\circ\text{C}$ unless otherwise noted) (continued)

Characteristic	Symbol	Min	Typ	Max	Unit
Dynamic Characteristics					
Reverse Transfer Capacitance ($V_{DS} = 13.6\text{ Vdc} \pm 30\text{ mV(rms)ac}$ @ 1 MHz, $V_{GS} = 0\text{ Vdc}$)	C_{rss}	—	1.6	—	pF
Output Capacitance ($V_{DS} = 13.6\text{ Vdc} \pm 30\text{ mV(rms)ac}$ @ 1 MHz, $V_{GS} = 0\text{ Vdc}$)	C_{oss}	—	49.5	—	pF
Input Capacitance ($V_{DS} = 13.6\text{ Vdc}$, $V_{GS} = 0\text{ Vdc} \pm 30\text{ mV(rms)ac}$ @ 1 MHz)	C_{iss}	—	109	—	pF
Functional Tests ⁽¹⁾ (In Freescale Narrowband Test Fixture, 50 ohm system) $V_{DD} = 13.6\text{ Vdc}$, $I_{DQ} = 10\text{ mA}$, $P_{out} = 31\text{ W}$, $f = 520\text{ MHz}$					
Common-Source Amplifier Power Gain	G_{ps}	16.5	17.7	19.0	dB
Drain Efficiency	η_D	70.0	71.4	—	%
Load Mismatch/Ruggedness (In Freescale Test Fixture, 50 ohm system, $I_{DQ} = 10\text{ mA}$)					
Frequency (MHz)	Signal Type	VSWR	P_{out} (W)	Test Voltage, V_{DD}	Result
520	CW	>65:1 at all Phase Angles	47 (3 dB Overdrive)	17	No Device Degradation

1. Measurement made with device in straight lead configuration before any lead forming operation is applied. Lead forming is used for gull wing (GN) parts.

TYPICAL CHARACTERISTICS

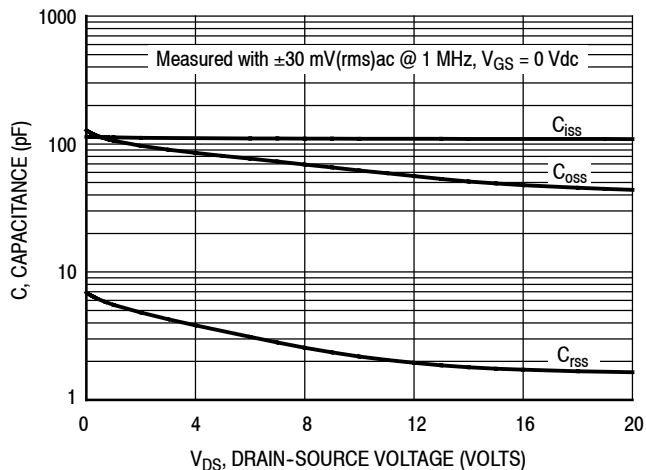

Figure 2. Capacitance versus Drain-Source Voltage

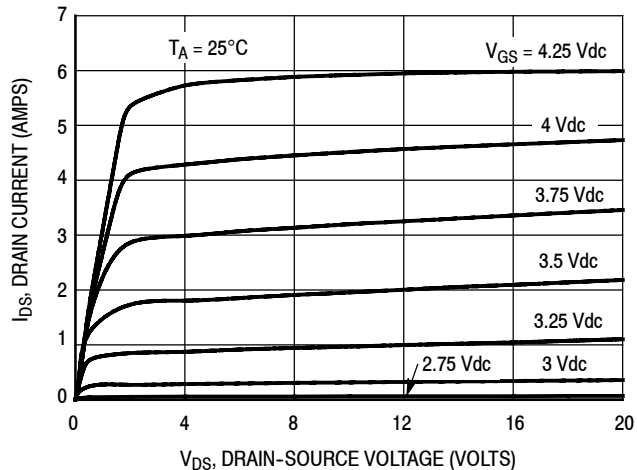
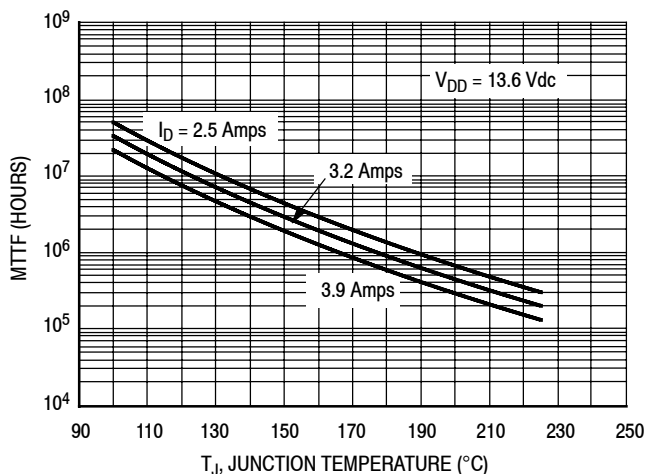

Figure 3. Drain Current versus Drain-Source Voltage
 Note: Measured with both sides of the transistor tied together.



Note: MTTF value represents the total cumulative operating time under indicated test conditions.

Figure 4. MTTF versus Junction Temperature - CW

520 MHz NARROWBAND PRODUCTION TEST FIXTURE

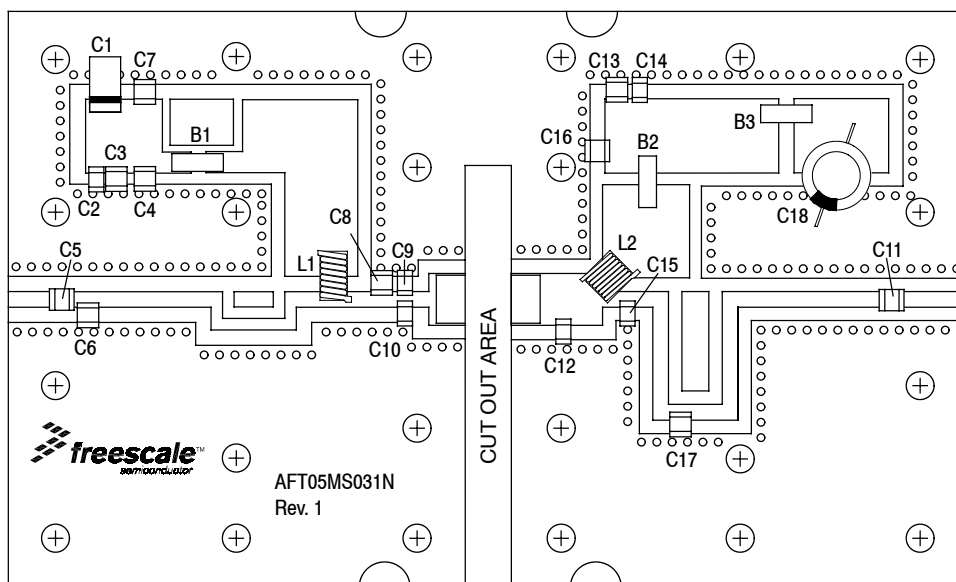

Figure 5. AFT05MS031NR1 Narrowband Test Circuit Component Layout — 520 MHz

Table 6. AFT05MS031NR1 Narrowband Test Circuit Component Designations and Values — 520 MHz

Part	Description	Part Number	Manufacturer
B1, B2, B3	RF Beads, Long	2743021447	Fair-Rite
C1	22 μ F, 35 V Tantalum Capacitor	T491X226K035AT	Kemet
C2, C14	0.01 μ F Chip Capacitors	C0805C103K5RAC	Kemet
C3, C13	0.1 μ F Chip Capacitors	CDR33BX104AKWS	Kemet
C4	200 pF Chip Capacitor	ATC100B201JT300XT	ATC
C5	6.2 pF Chip Capacitor	ATC100B6R2JT500XT	ATC
C6	3.9 pF Chip Capacitor	ATC100B3R9JT500XT	ATC
C7, C16	180 pF Chip Capacitors	ATC100B181JT200XT	ATC
C8	10 pF Chip Capacitor	ATC100B100JT500XT	ATC
C9, C10, C11, C12	36 pF Chip Capacitors	ATC100B360JT500XT	ATC
C15	27 pF Chip Capacitor	ATC100B270JT500XT	ATC
C17	7.5 pF Chip Capacitor	ATC100B7R5JT500XT	ATC
C18	470 μ F, 63 V Electrolytic Capacitor	SME63V471M12X25LL	United Chemi-Con
L1	43 nH, 10 Turn Inductor	B10TJLC	Coilcraft
L2	56 nH Inductor	1812SMS-56NJLC	Coilcraft
PCB	0.030", $\epsilon_r = 2.55$	AD255A	Arlon

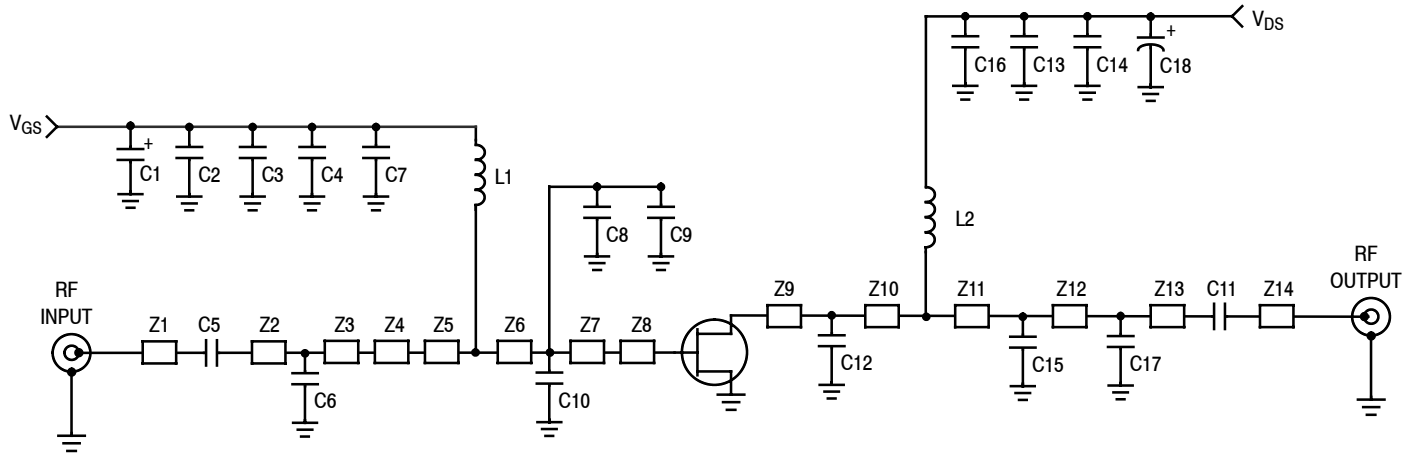

Figure 6. AFT05MS031NR1 Narrowband Test Circuit Schematic — 520 MHz

Table 7. AFT05MS031NR1 Narrowband Test Circuit Microstrips — 520 MHz

Microstrip	Description	Microstrip	Description
Z1	0.199" × 0.082" Microstrip	Z8	0.190" × 0.270" Microstrip
Z2	0.017" × 0.082" Microstrip	Z9	0.257" × 0.275" Microstrip
Z3*	0.670" × 0.082" Microstrip	Z10	0.145" × 0.275" Microstrip
Z4*	0.560" × 0.060" Microstrip	Z11	0.091" × 0.082" Microstrip
Z5*	0.370" × 0.082" Microstrip	Z12*	0.1322" × 0.082" Microstrip
Z6	0.079" × 0.082" Microstrip	Z13*	0.1420" × 0.082" Microstrip
Z7	0.352" × 0.082" Microstrip	Z14	0.315" × 0.082" Microstrip

* Line length includes microstrip bends

TYPICAL CHARACTERISTICS — 520 MHz

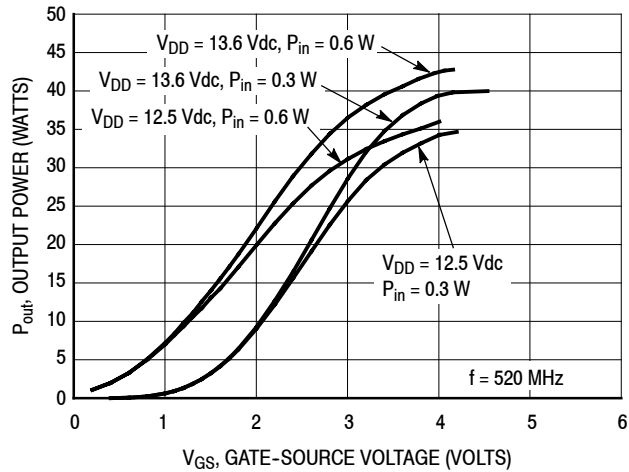

Figure 7. Output Power versus Gate-Source Voltage

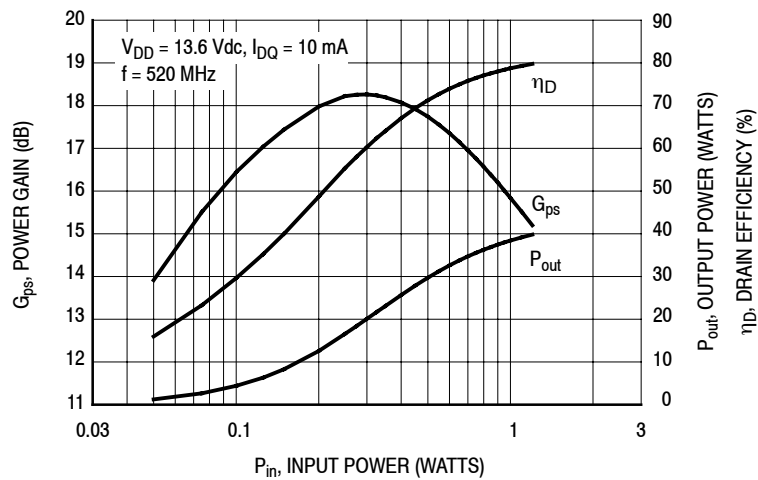

Figure 8. Power Gain, Output Power and Drain Efficiency versus Input Power

$V_{DD} = 13.6 \text{ Vdc}$, $I_{DQ} = 10 \text{ mA}$, $P_{out} = 31 \text{ W Avg.}$

f MHz	Z_{source} Ω	Z_{load} Ω
520	$0.72 + j1.77$	$1.54 + j0.80$

Z_{source} = Test circuit impedance as measured from gate to ground.

Z_{load} = Test circuit impedance as measured from drain to ground.

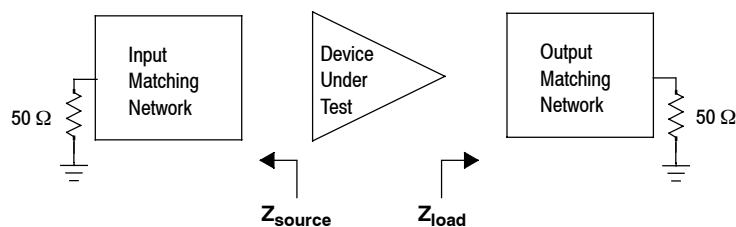

Figure 9. Narrowband Series Equivalent Source and Load Impedance — 520 MHz

380-450 MHz UHF WIDEBAND REFERENCE CIRCUIT, 50 OHM SYSTEM

Table 8. 380-450 MHz UHF Wideband Performance (13.6 Vdc, I_{DQ} = 100 mA, T_A = 25°C, CW)

Frequency (MHz)	G _{ps} (dB)	η _D (%)	P _{1dB} (W)
380	18.7	64.1	31
420	18.6	67.0	31
450	18.3	68.1	31

Table 9. Load Mismatch/Ruggedness (In Freescale Reference Circuit)

Frequency (MHz)	Signal Type	VSWR	P _{out} (W)	Test Voltage, V _{DD}	Result
420	CW	>65:1 at all Phase Angles	62 (3 dB Overdrive)	17	No Device Degradation

380-450 MHz UHF WIDEBAND REFERENCE CIRCUIT

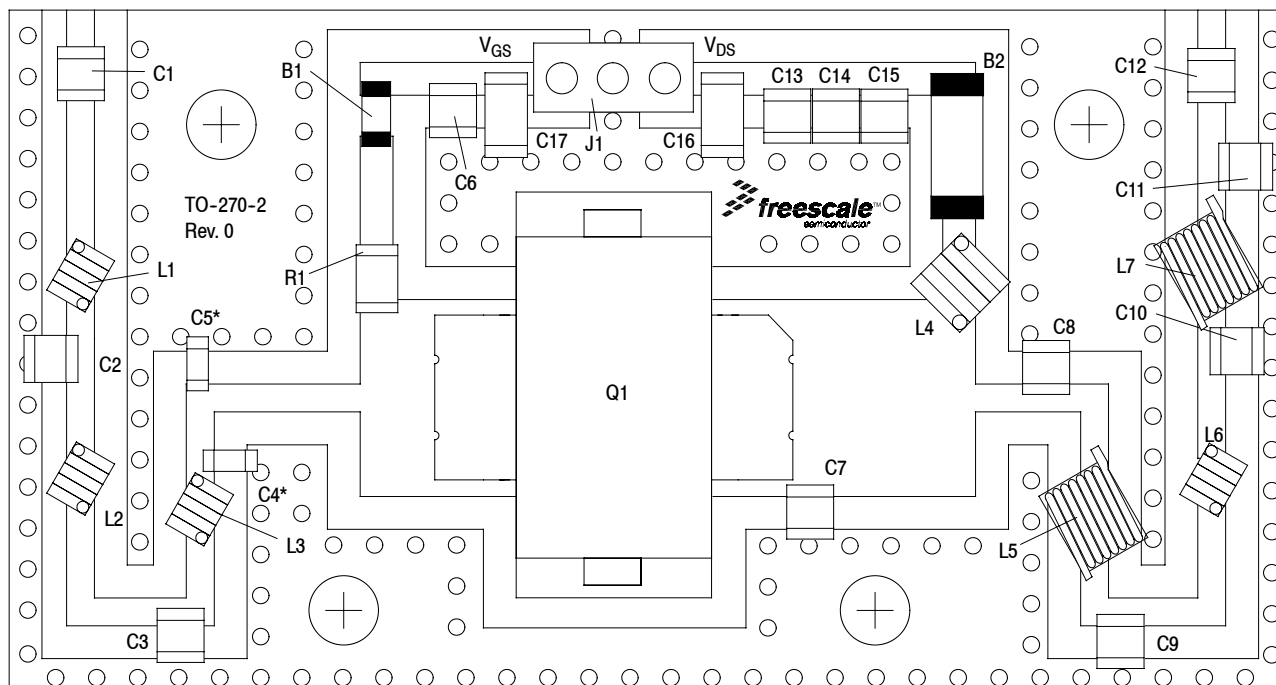

* C4 and C5 are mounted vertically.

Figure 10. AFT05MS031NR1 UHF Wideband Reference Circuit Component Layout — 380-450 MHz

Table 10. AFT05MS031NR1 UHF Wideband Reference Circuit Component Designations and Values — 380-450 MHz

Part	Description	Part Number	Manufacturer
B1	Low Current Ferrite Bead	2508051107Y0	Fair-Rite
B2	High Current Ferrite Bead	2518065007Y6	Fair-Rite
C1, C5	56 pF Chip Capacitors	ATC600F560JT250XT	ATC
C2	3.9 pF Chip Capacitor	ATC600F3R9BT250XT	ATC
C3	18 pF Chip Capacitor	ATC600F180JT250XT	ATC
C4	47 pF Chip Capacitor	ATC600F470JT250XT	ATC
C6, C12, C15	240 pF Chip Capacitors	ATC600F241JT250XT	ATC
C7	24 pF Chip Capacitor	ATC600F240JT250XT	ATC
C8	68 pF Chip Capacitor	ATC600F680JT250XT	ATC
C9	27 pF Chip Capacitor	ATC600F270JT250XT	ATC
C10	8.2 pF Chip Capacitor	ATC600F8R2BT250XT	ATC
C11	3.0 pF Chip Capacitor	ATC600F3R0BT250XT	ATC
C13	0.1 μ F Chip Capacitor	GRM21BR71H104KA01B	Murata
C14	1 μ F Chip Capacitor	GRM21BR71H105KA12L	Murata
C16, C17	10 μ F Chip Capacitors	GRM31CR61H106KA12L	Murata
J1	3 Pin Connector	AMP-9-146305-0	TE Connectivity
L1, L2, L3, L6	5.5 nH Inductors	0806SQ-5N5GLC	Coilcraft
L4	17 nH Inductor	0908SQ-17NGLC	Coilcraft
L5	1.65 nH Inductor	0906-2KLC	Coilcraft
L7	2.55 nH Inductor	0906-3JLC	Coilcraft
Q1	RF Power LDMOS Transistor	AFT05MS031NR1	Freescale
R1	62 Ω , 1/4 W Chip Resistor	RG2012N-620-BT1	Susumu
PCB	0.020", $\epsilon_r = 4.9$	S1000-2, FR4	Shengyi

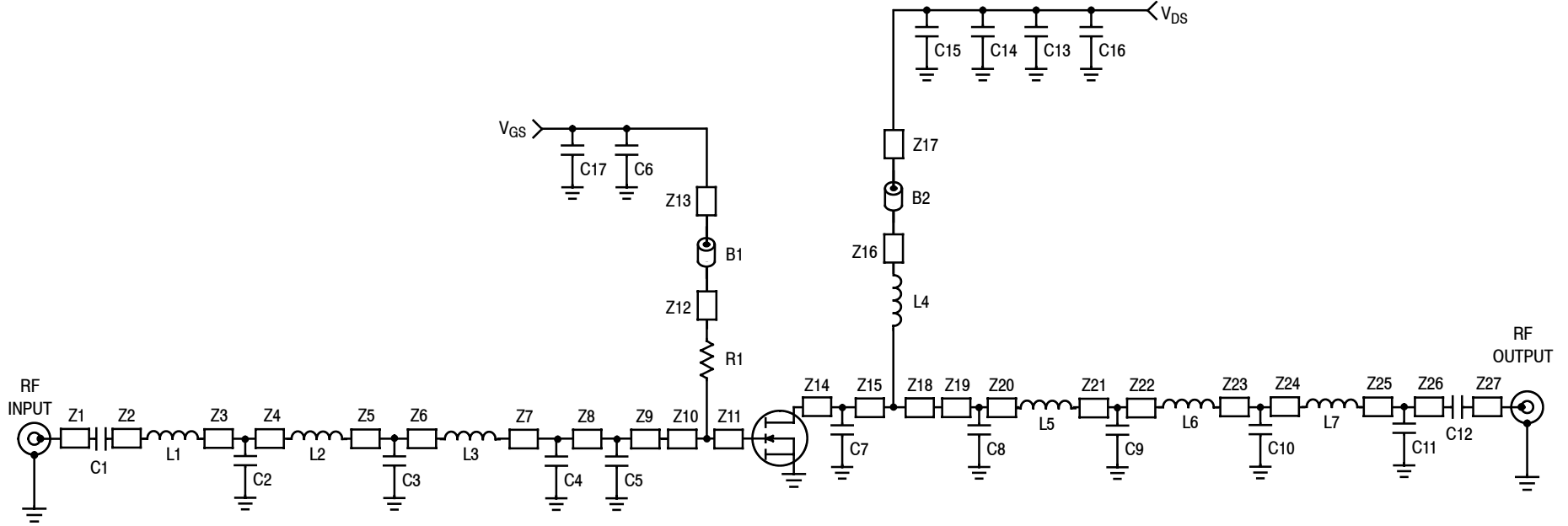

Figure 11. AFT05MS031NR1 UHF Wideband Reference Circuit Schematic — 380-450 MHz

Table 11. AFT05MS031NR1 UHF Wideband Reference Circuit Microstrips — 380-450 MHz

Microstrip	Description	Microstrip	Description	Microstrip	Description
Z1, Z27	0.034" × 0.060" Microstrip	Z9	0.034" × 0.178" Microstrip	Z19	0.034" × 0.057" Microstrip
Z2	0.034" × 0.200" Microstrip	Z10	0.240" × 0.048" Microstrip	Z20*	0.034" × 0.201" Microstrip
Z3	0.034" × 0.056" Microstrip	Z11	0.240" × 0.142" Microstrip	Z21*	0.034" × 0.110" Microstrip
Z4	0.034" × 0.154" Microstrip	Z12, Z16	0.034" × 0.149" Microstrip	Z22*	0.034" × 0.361" Microstrip
Z5*	0.034" × 0.237" Microstrip	Z13, Z17*	0.034" × 0.085" Microstrip	Z23	0.034" × 0.112" Microstrip
Z6*	0.034" × 0.234" Microstrip	Z14	0.240" × 0.090" Microstrip	Z25	0.034" × 0.073" Microstrip
Z7	0.034" × 0.010" Microstrip	Z15	0.240" × 0.186" Microstrip	Z26	0.034" × 0.077" Microstrip
Z8, Z24	0.034" × 0.083" Microstrip	Z18	0.240" × 0.044" Microstrip		

* Line length includes microstrip bends

**TYPICAL CHARACTERISTICS — 380-450 MHz UHF WIDEBAND
REFERENCE CIRCUIT**

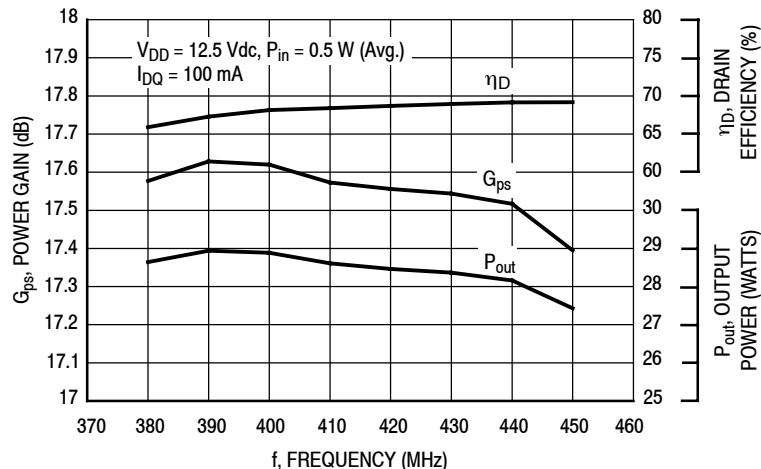

Figure 12. Power Gain, Output Power and Drain Efficiency versus Frequency at a Constant Input Power — 12.5 V

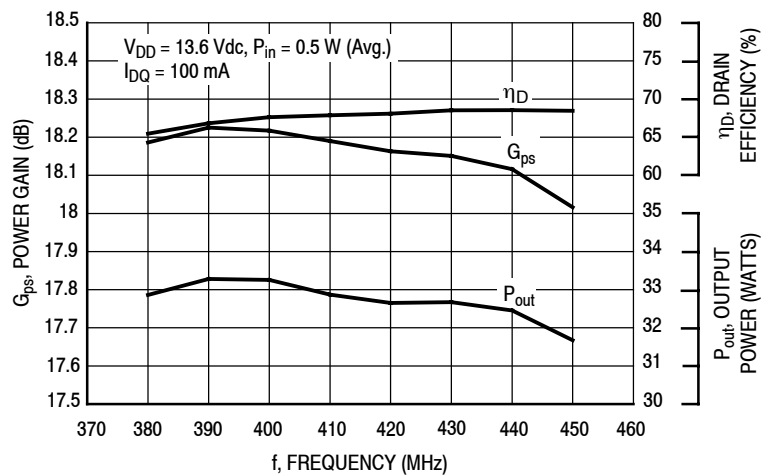

Figure 13. Power Gain, Output Power and Drain Efficiency versus Frequency at a Constant Input Power — 13.6 V

**TYPICAL CHARACTERISTICS — 380-450 MHz UHF WIDEBAND
REFERENCE CIRCUIT**

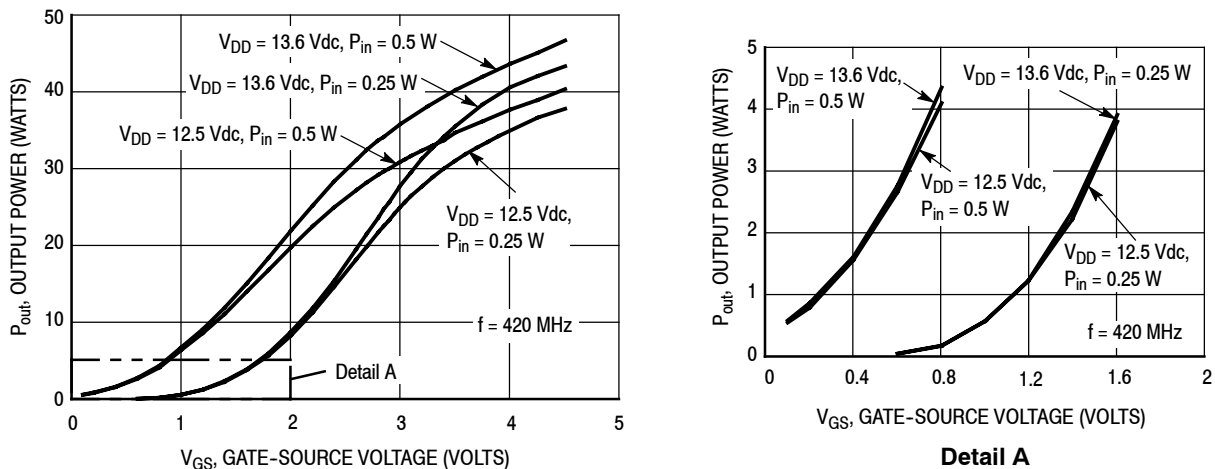

Figure 14. Output Power versus Gate-Source Voltage

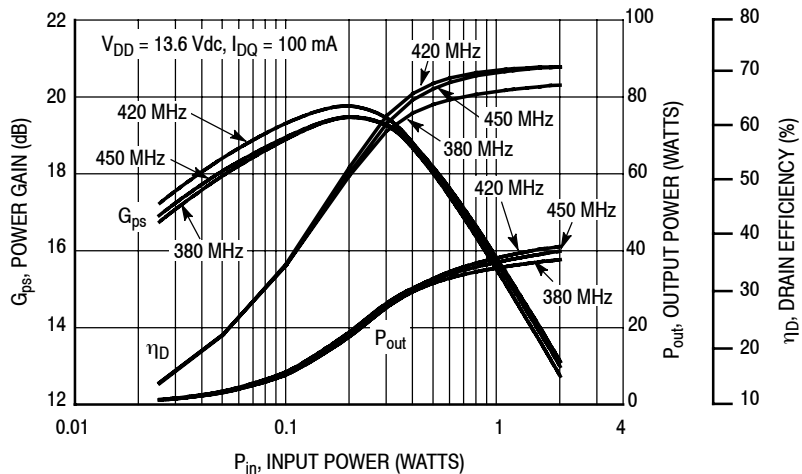
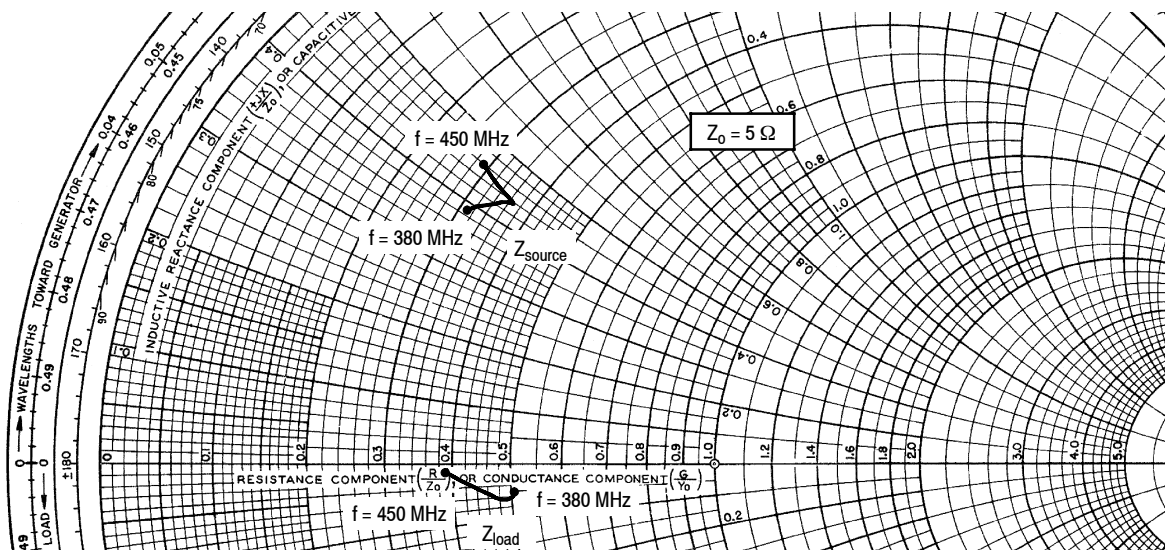

Figure 15. Power Gain, Output Power and Drain Efficiency versus Input Power and Frequency

380-450 MHz UHF WIDEBAND REFERENCE CIRCUIT



$V_{DD} = 13.6 \text{ Vdc}$, $I_{DQ} = 10 \text{ mA}$, $P_{out} = 31 \text{ W Avg.}$

f MHz	Z _{source} Ω	Z _{load} Ω
380	1.57 + j1.94	2.53 - j0.27
390	1.66 + j2.07	2.53 - j0.26
400	1.74 + j2.16	2.56 - j0.27
410	1.79 + j2.20	2.49 - j0.29
420	1.79 + j2.21	2.38 - j0.28
430	1.74 + j2.21	2.26 - j0.24
440	1.62 + j2.23	2.11 - j0.16
450	1.45 + j2.29	1.95 - j0.05

Z_{source} = Test circuit impedance as measured from gate to ground.

Z_{load} = Test circuit impedance as measured from drain to ground.

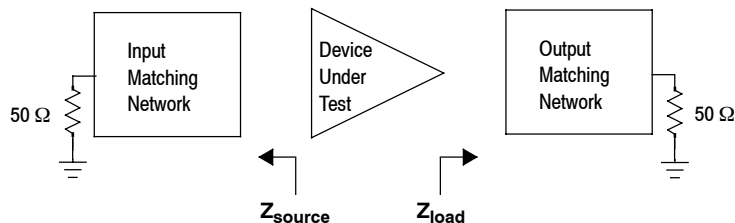

Figure 16. UHF Wideband Series Equivalent Source and Load Impedance — 380-450 MHz

450-520 MHz UHF WIDEBAND REFERENCE CIRCUIT, 50 OHM SYSTEM

Table 12. 450-520 MHz UHF Wideband Performance (13.6 Vdc, I_{DQ} = 100 mA, T_A = 25°C, CW)

Frequency (MHz)	G _{ps} (dB)	η _D (%)	P _{1dB} (W)
450	17.7	62.0	31
490	18.7	63.8	31
520	17.9	67.0	31

Table 13. Load Mismatch/Ruggedness (In Freescale Reference Circuit)

Frequency (MHz)	Signal Type	VSWR	P _{out} (W)	Test Voltage, V _{DD}	Result
490	CW	>65:1 at all Phase Angles	62 (3 dB Overdrive)	17	No Device Degradation

450-520 MHz UHF WIDEBAND REFERENCE CIRCUIT

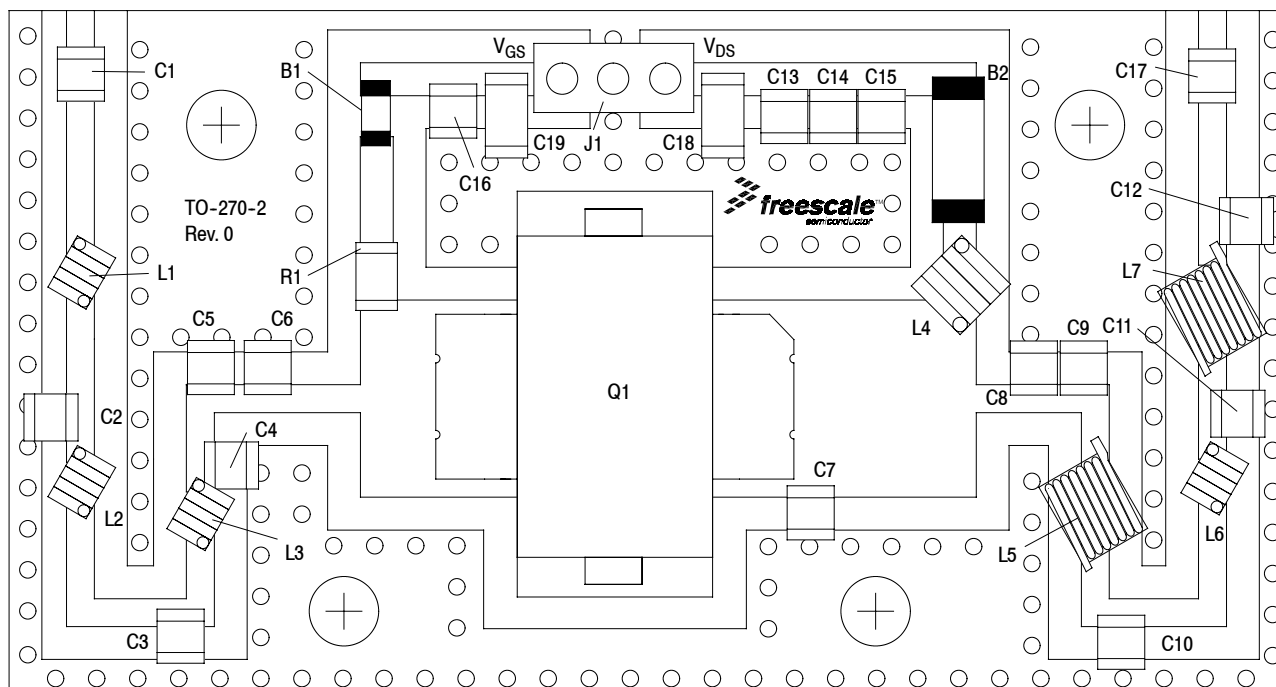

Figure 17. AFT05MS031NR1 UHF Wideband Reference Circuit Component Layout — 450-520 MHz

Table 14. AFT05MS031NR1 UHF Wideband Reference Circuit Component Designations and Values — 450-520 MHz

Part	Description	Part Number	Manufacturer
B1	Low Current Ferrite Bead	2508051107Y0	Fair-Rite
B2	High Current Ferrite Bead	2518065007Y6	Fair-Rite
C1	56 pF Chip Capacitor	ATC600F560JT250XT	ATC
C2	2.7 pF Chip Capacitor	ATC600F2R7BT250XT	ATC
C3	12 pF Chip Capacitor	ATC600F120JT250XT	ATC
C4, C9	27 pF Chip Capacitors	ATC600F270JT250XT	ATC
C5, C8	33 pF Chip Capacitors	ATC600F330JT250XT	ATC
C6	39 pF Chip Capacitor	ATC600F390JT250XT	ATC
C7, C10	18 pF Chip Capacitors	ATC600F180JT250XT	ATC
C11	8.2 pF Chip Capacitor	ATC600F8R2BT250XT	ATC
C12	1.8 pF Chip Capacitor	ATC600F1R8BT250XT	ATC
C13	0.1 μ F Chip Capacitor	GRM21BR71H104KA01B	Murata
C14	1 μ F Chip Capacitor	GRM21BR71H105KA12L	Murata
C15, C16, C17	240 pF Chip Capacitors	ATC600F241JT250XT	ATC
C18, C19	10 μ F Chip Capacitors	GRM31CR61H106KA12L	Murata
J1	3 Pin Connector	AMP-9-146305-0	TE Connectivity
L1, L3	6.0 nH Inductors	0806SQ-6N0GLC	Coilcraft
L2, L6	5.5 nH Inductors	0806SQ5N5GLC	Coilcraft
L4	17 nH Inductor	0908SQ-17NGLC	Coilcraft
L5, L7	1.65 nH Inductors	0906-2KLC	Coilcraft
Q1	RF Power LDMOS Transistor	AFT05MS031NR1	Freescale
R1	62 Ω , 1/4 W Chip Resistor	RG2012N-620-BT1	Susumu
PCB	0.020", $\epsilon_r = 4.9$	S1000-2, FR4	Shengyi

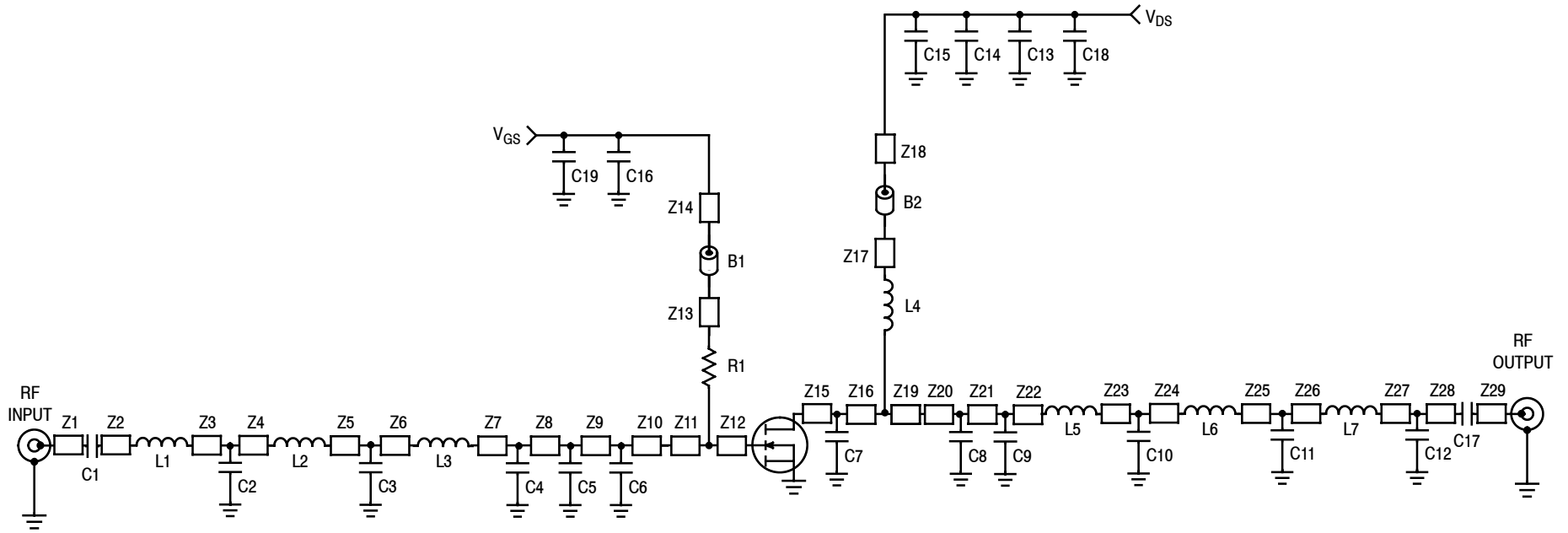

Figure 18. AFT05MS031NR1 UHF Wideband Reference Circuit Schematic — 450-520 MHz

Table 15. AFT05MS031NR1 UHF Wideband Reference Circuit Microstrips — 450-520 MHz

Microstrip	Description	Microstrip	Description	Microstrip	Description
Z1, Z9, Z29	0.034" × 0.060" Microstrip	Z11	0.240" × 0.010" Microstrip	Z23*	0.034" × 0.118" Microstrip*
Z2	0.034" × 0.200" Microstrip	Z12	0.240" × 0.180" Microstrip	Z24*	0.034" × 0.295" Microstrip*
Z3	0.034" × 0.128" Microstrip	Z13, Z17	0.034" × 0.149" Microstrip	Z25	0.034" × 0.018" Microstrip
Z4	0.034" × 0.054" Microstrip	Z14	0.034" × 0.084" Microstrip	Z26	0.034" × 0.177" Microstrip
Z5*	0.034" × 0.202" Microstrip	Z15	0.240" × 0.054" Microstrip	Z27	0.034" × 0.022" Microstrip
Z6*	0.034" × 0.160" Microstrip	Z16	0.240" × 0.170" Microstrip	Z28	0.034" × 0.188" Microstrip
Z7, Z21	0.034" × 0.010" Microstrip	Z19	0.240" × 0.044" Microstrip	Z18	0.034" × 0.184" Microstrip
Z8	0.034" × 0.115" Microstrip	Z20	0.034" × 0.057" Microstrip		
Z10	0.034" × 0.150" Microstrip	Z22	0.034" × 0.176" Microstrip		

* Line length includes microstrip bends

**TYPICAL CHARACTERISTICS — 450-520 MHz UHF WIDEBAND
REFERENCE CIRCUIT**

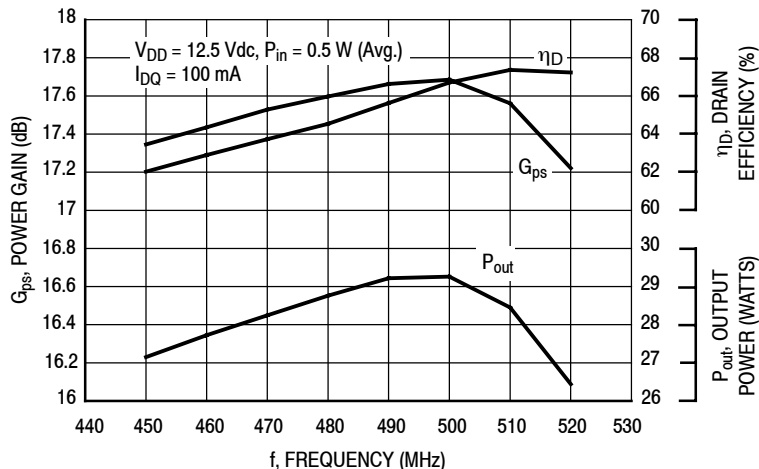

Figure 19. Power Gain, Drain Efficiency and Output Power versus Frequency at a Constant Input Power — 12.5 V

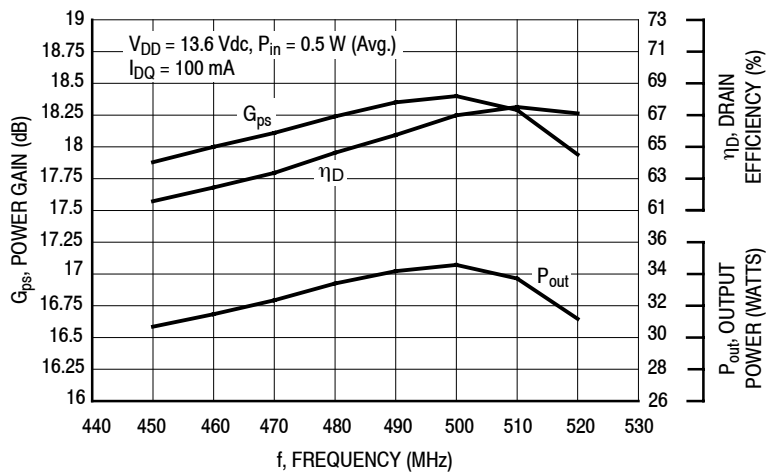

Figure 20. Power Gain, Drain Efficiency and Output Power versus Frequency at a Constant Input Power — 13.6 V

**TYPICAL CHARACTERISTICS — 450-520 MHz UHF WIDEBAND
REFERENCE CIRCUIT**

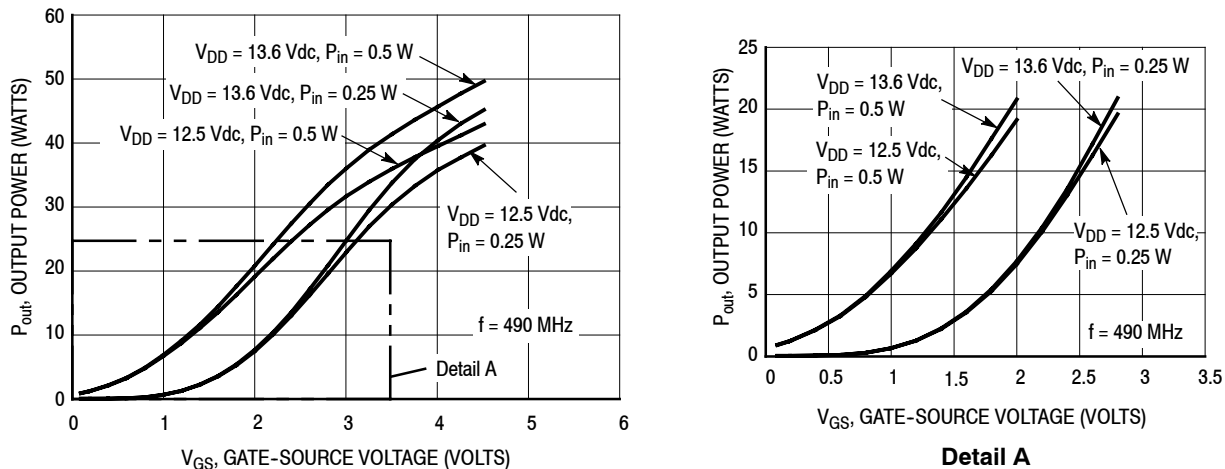

Figure 21. Output Power versus Gate-Source Voltage

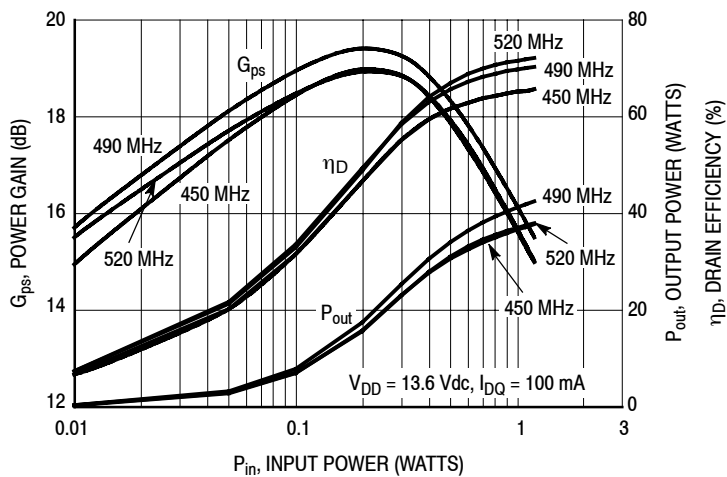
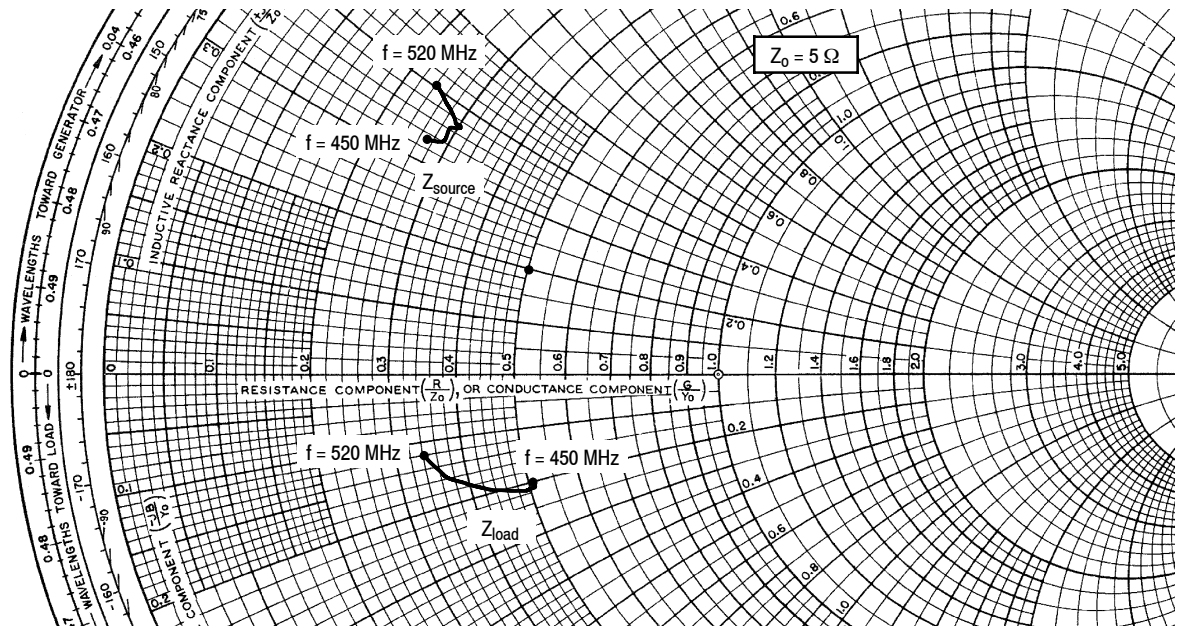

Figure 22. Power Gain, Output Power and Drain Efficiency versus Input Power and Frequency

450-520 MHz UHF WIDEBAND REFERENCE CIRCUIT



$V_{DD} = 13.6 \text{ Vdc}$, $I_{DQ} = 100 \text{ mA}$, $P_{out} = 31 \text{ W Avg.}$

f MHz	$Z_{source} \Omega$	$Z_{load} \Omega$
450	$1.37 + j1.64$	$2.57 - j1.01$
460	$1.43 + j1.72$	$2.49 - j1.03$
470	$1.47 + j1.79$	$2.38 - j1.03$
480	$1.49 + j1.83$	$2.26 - j1.01$
490	$1.47 + j1.86$	$2.11 - j0.95$
500	$1.41 + j1.89$	$1.97 - j0.87$
510	$1.32 + j1.93$	$1.82 - j0.76$
520	$1.20 + j1.99$	$1.68 - j0.62$

Z_{source} = Test circuit impedance as measured from gate to ground.

Z_{load} = Test circuit impedance as measured from drain to ground.

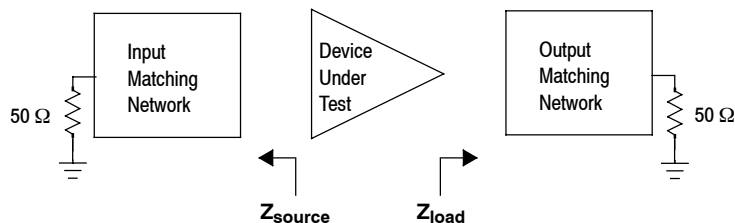
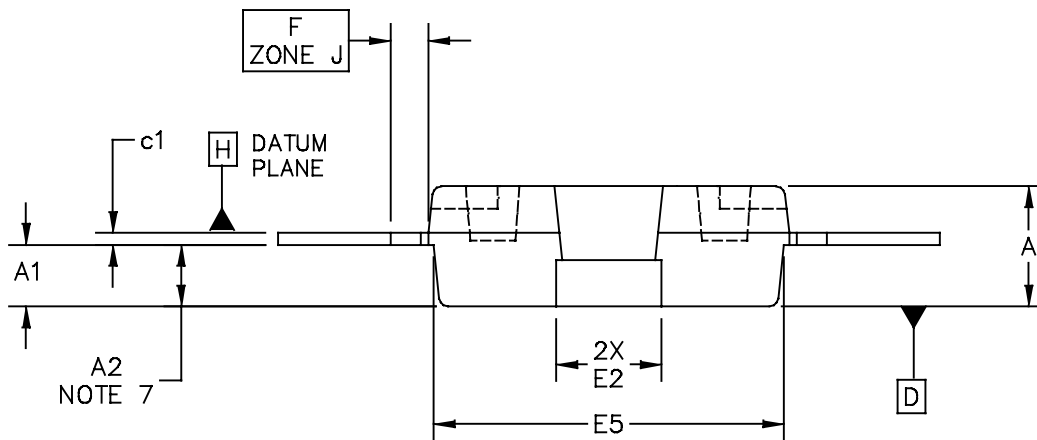
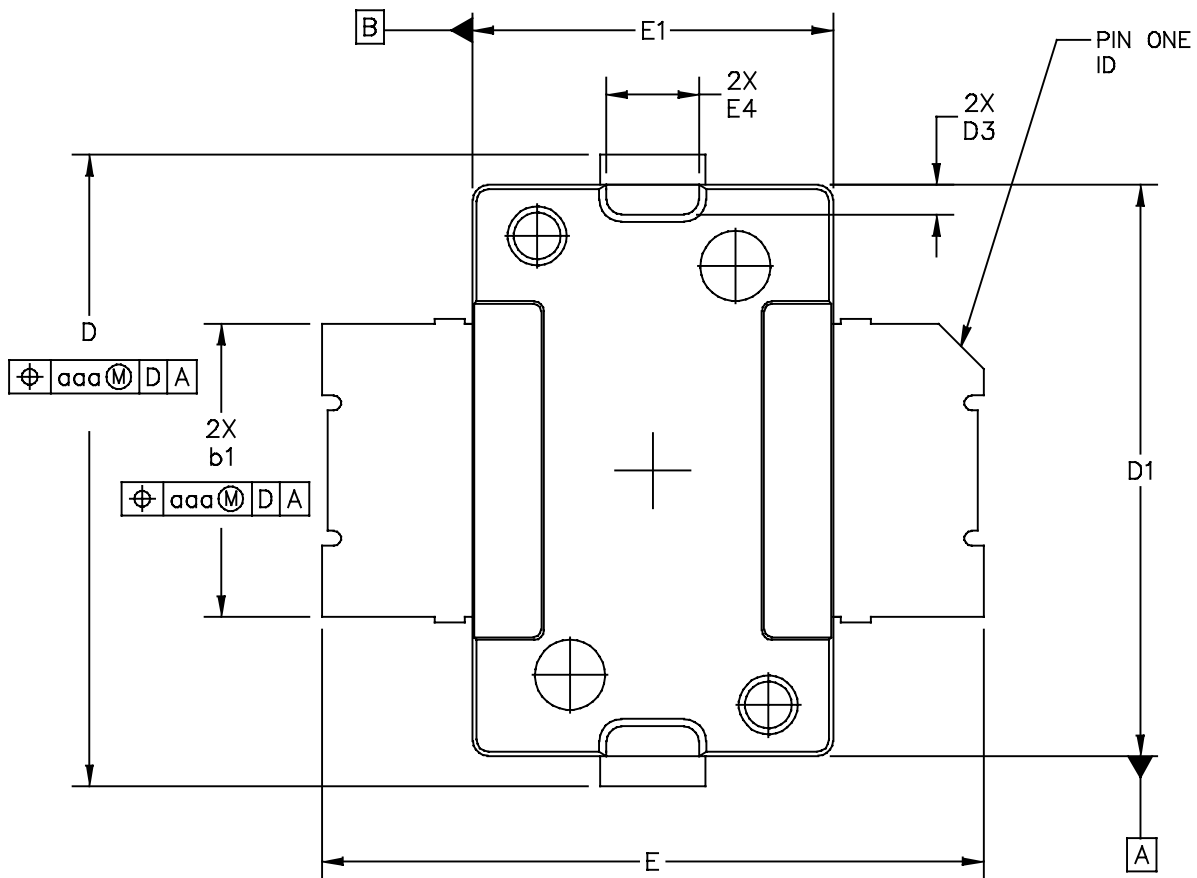
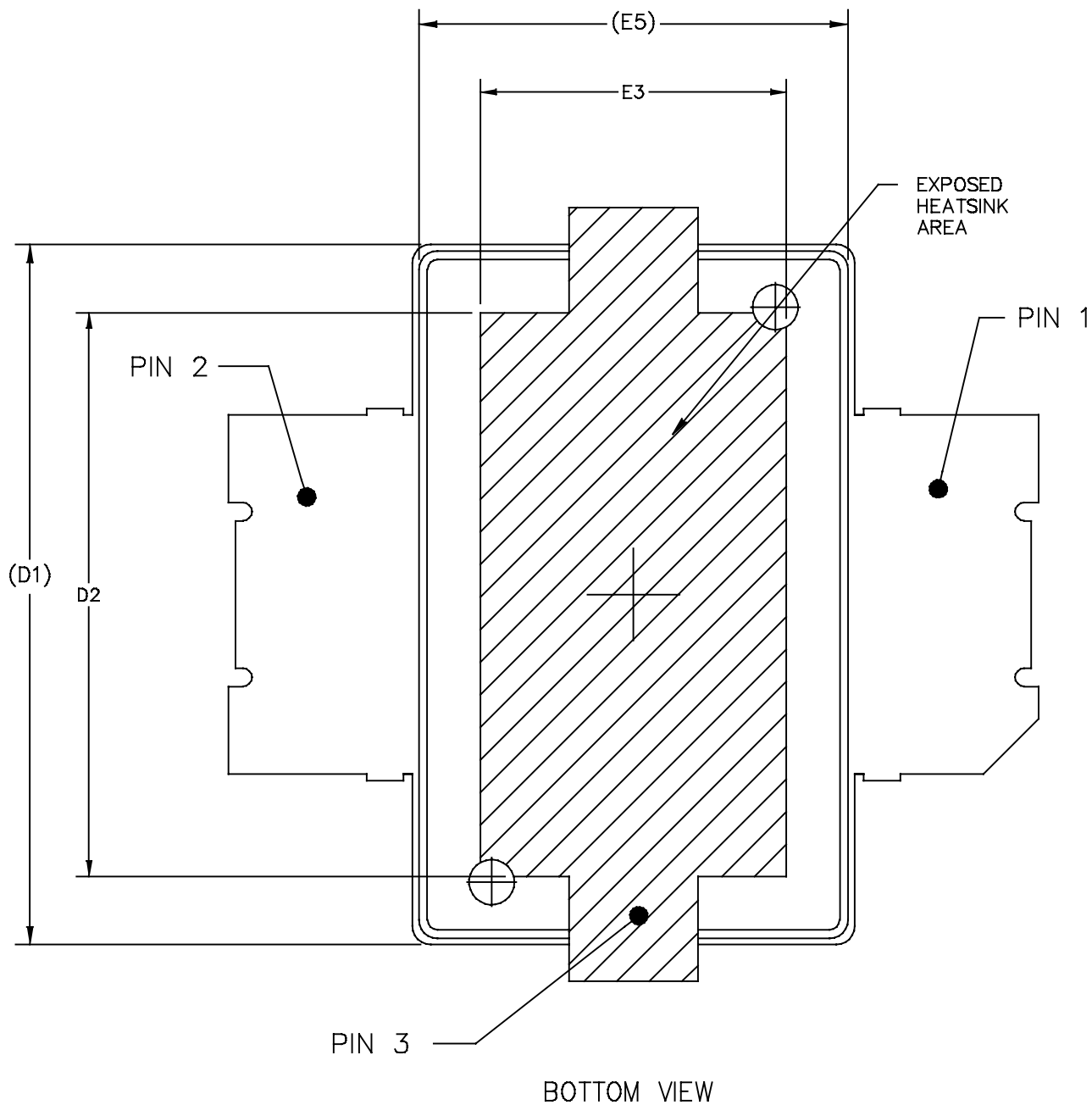

Figure 23. UHF Wideband Series Equivalent Source and Load Impedance — 450-520 MHz

PACKAGE DIMENSIONS



© FREESCALE SEMICONDUCTOR, INC. ALL RIGHTS RESERVED.	MECHANICAL OUTLINE	PRINT VERSION NOT TO SCALE	
TITLE: TO-270 SURFACE MOUNT	DOCUMENT NO: 98ASH98117A	REV: K	
	CASE NUMBER: 1265-09	29 JUN 2007	
	STANDARD: JEDEC TO-270 AA		



© FREESCALE SEMICONDUCTOR, INC. ALL RIGHTS RESERVED.	MECHANICAL OUTLINE	PRINT VERSION NOT TO SCALE	
TITLE: TO-270 SURFACE MOUNT	DOCUMENT NO: 98ASH98117A	REV: K	
	CASE NUMBER: 1265-09	29 JUN 2007	
	STANDARD: JEDEC TO-270 AA		

AFT05MS031NR1 AFT05MS031GMR1

NOTES:

1. CONTROLLING DIMENSION: INCH
2. INTERPRET DIMENSIONS AND TOLERANCES PER ASME Y14.5M-1994.
3. DATUM PLANE -H- IS LOCATED AT TOP OF LEAD AND IS COINCIDENT WITH THE LEAD WHERE THE LEAD EXITS THE PLASTIC BODY AT THE TOP OF THE PARTING LINE.
4. DIMENSIONS "D1" AND "E1" DO NOT INCLUDE MOLD PROTRUSION. ALLOWABLE PROTRUSION IS .006 PER SIDE. DIMENSIONS "D1" AND "E1" DO INCLUDE MOLD MISMATCH AND ARE DETERMINED AT DATUM PLANE -H-.
5. DIMENSION "b1" DOES NOT INCLUDE DAMBAR PROTRUSION. ALLOWABLE DAMBAR PROTRUSION SHALL BE .005 TOTAL IN EXCESS OF THE "b1" DIMENSION AT MAXIMUM MATERIAL CONDITION.
6. DATUMS -A- AND -B- TO BE DETERMINED AT DATUM PLANE -H-.
7. DIMENSION "A2" APPLIES WITHIN ZONE "J" ONLY.
8. DIMENSIONS "D" AND "E2" DO NOT INCLUDE MOLD PROTRUSION. OVERALL LENGTH INCLUDING MOLD PROTRUSION SHOULD NOT EXCEED 0.430 INCH FOR DIMENSION "D" AND 0.080 INCH FOR DIMENSION "E2". DIMENSIONS "D" AND "E2" DO INCLUDE MOLD MISMATCH AND ARE DETERMINED AT DATUM PLANE -D-.

STYLE 1:

- PIN 1 - DRAIN
- PIN 2 - GATE
- PIN 3 - SOURCE

DIM	INCH		MILLIMETER		DIM	INCH		MILLIMETER	
	MIN	MAX	MIN	MAX		MIN	MAX	MIN	MAX
A	.078	.082	1.98	2.08	F	.025 BSC		0.64 BSC	
A1	.039	.043	0.99	1.09	b1	.193	.199	4.90	5.06
A2	.040	.042	1.02	1.07	c1	.007	.011	0.18	0.28
D	.416	.424	10.57	10.77	aaa	.004		0.10	
D1	.378	.382	9.60	9.70					
D2	.290	----	7.37	----					
D3	.016	.024	0.41	0.61					
E	.436	.444	11.07	11.28					
E1	.238	.242	6.04	6.15					
E2	.066	.074	1.68	1.88					
E3	.150	----	3.81	----					
E4	.058	.066	1.47	1.68					
E5	.231	.235	5.87	5.97					

© FREESCALE SEMICONDUCTOR, INC. ALL RIGHTS RESERVED.		MECHANICAL OUTLINE		PRINT VERSION NOT TO SCALE	
TITLE: TO-270 SURFACE MOUNT		DOCUMENT NO: 98ASH98117A		REV: K	
		CASE NUMBER: 1265-09		29 JUN 2007	
		STANDARD: JEDEC TO-270 AA			

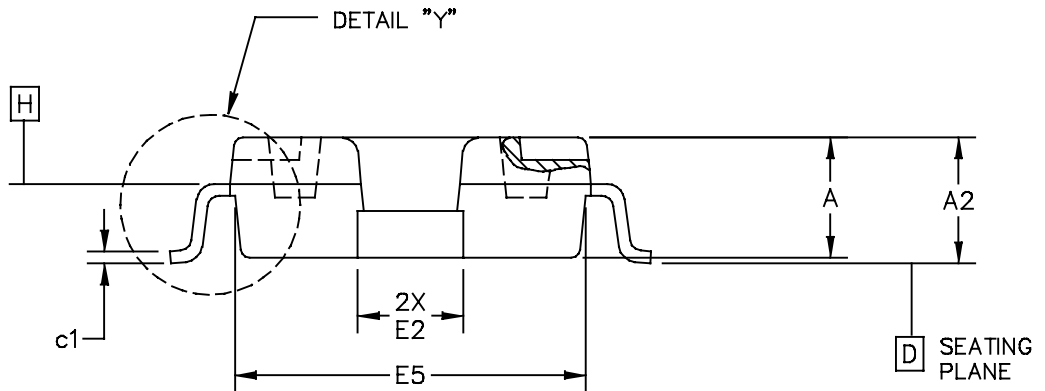
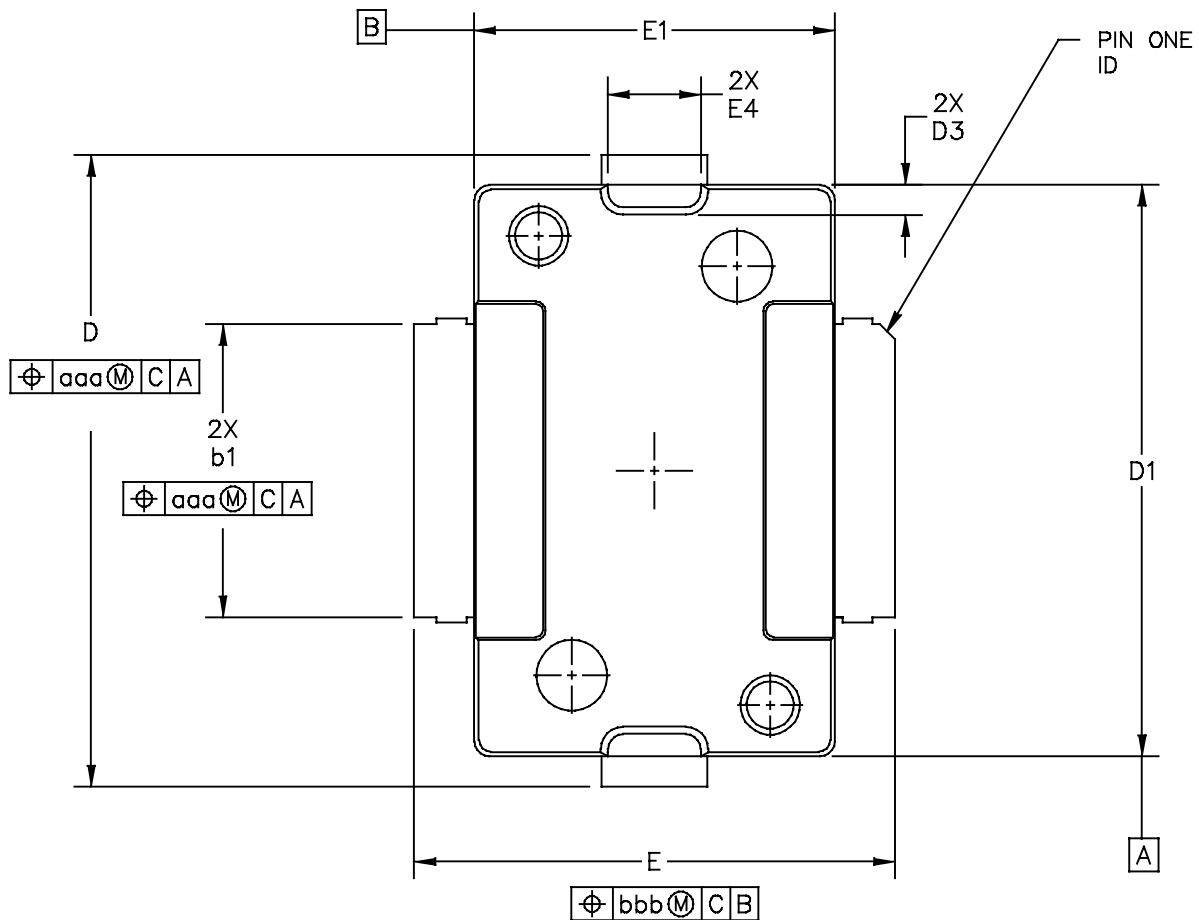

© FREESCALE SEMICONDUCTOR, INC. ALL RIGHTS RESERVED.		MECHANICAL OUTLINE	PRINT VERSION NOT TO SCALE
TITLE: TO-270 GULL WING		DOCUMENT NO: 98ASA99301D	REV: C
		CASE NUMBER: 1265A-03	02 JUL 2007
		STANDARD: JEDEC TO-270 BA	

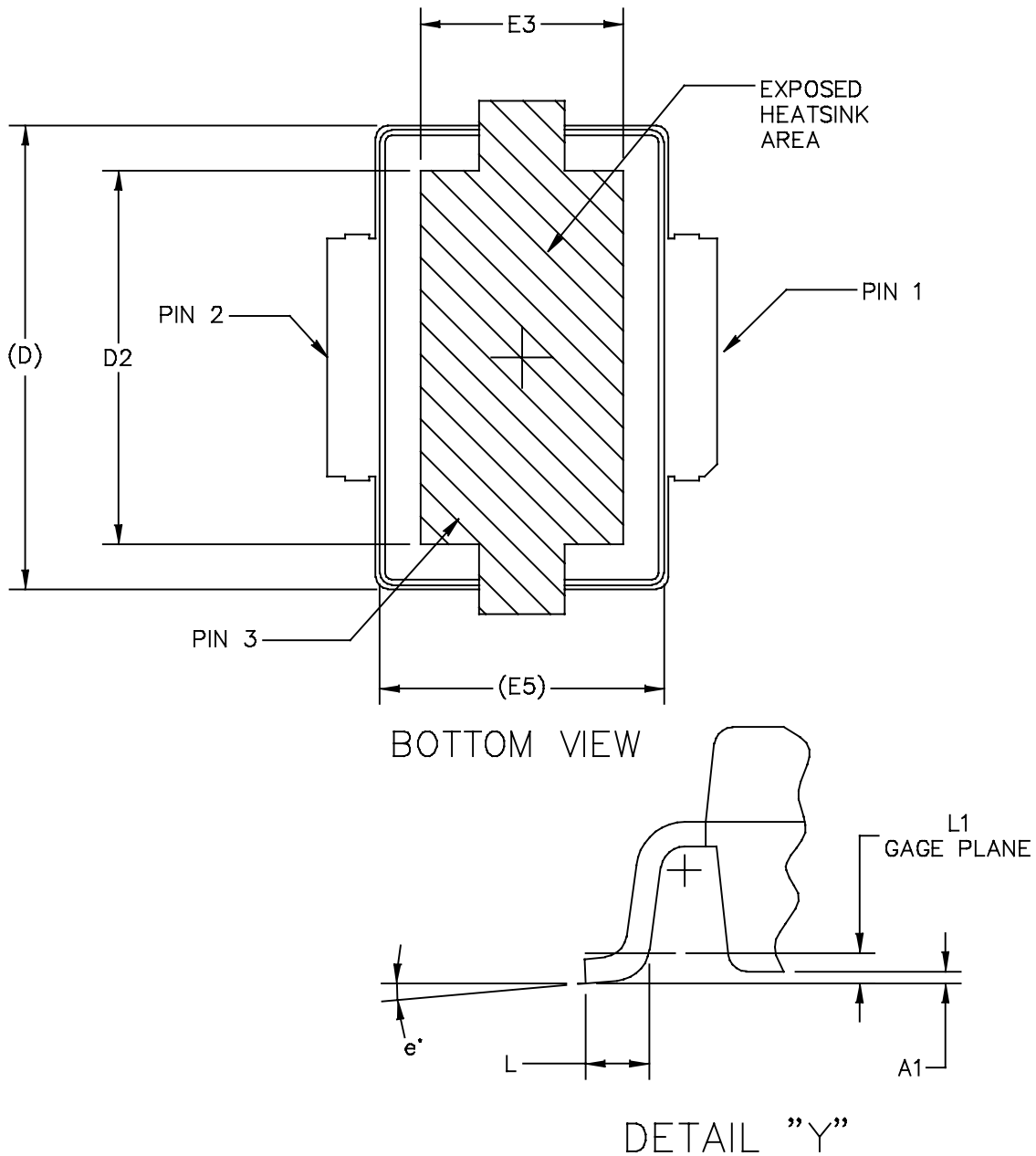

© FREESCALE SEMICONDUCTOR, INC. ALL RIGHTS RESERVED.	MECHANICAL OUTLINE	PRINT VERSION NOT TO SCALE	
TITLE: TO-270 GULL WING	DOCUMENT NO: 98ASA99301D		REV: C
	CASE NUMBER: 1265A-03		02 JUL 2007
	STANDARD: JEDEC TO-270 BA		

NOTES:

1. CONTROLLING DIMENSION: INCH
2. INTERPRET DIMENSIONS AND TOLERANCES PER ASME Y14.5M-1994.
3. DATUM PLANE -H- IS LOCATED AT TOP OF LEAD AND IS COINCIDENT WITH THE LEAD WHERE THE LEAD EXITS THE PLASTIC BODY AT THE TOP OF THE PARTING LINE.
4. DIMENSIONS "D1" AND "E1" DO NOT INCLUDE MOLD PROTRUSION. ALLOWABLE PROTRUSION IS .006 PER SIDE. DIMENSIONS "D1 AND "E1" DO INCLUDE MOLD MISMATCH AND ARE DETERMINED AT DATUM PLANE -H-.
5. DIMENSION b1 DOES NOT INCLUDE DAMBAR PROTRUSION. ALLOWABLE DAMBAR PROTRUSION SHALL BE .005 TOTAL IN EXCESS OF THE b1 DIMENSION AT MAXIMUM MATERIAL CONDITION.
6. DATUMS -A- AND -B- TO BE DETERMINED AT DATUM PLANE -H-.
7. DIMENSIONS "D" AND "E2" DO NOT INCLUDE MOLD PROTRUSION. ALLOWABLE PROTRUSION IS .003 PER SIDE. DIMENSIONS "D AND "E2" DO INCLUDE MOLD MISMATCH AND ARE DETERMINED AT DATUM PLANE -D-.

STYLE 1:

- PIN 1 - DRAIN
- PIN 2 - GATE
- PIN 3 - SOURCE

DIM	INCH		MILLIMETER		DIM	INCH		MILLIMETER	
	MIN	MAX	MIN	MAX		MIN	MAX	MIN	MAX
A	.078	.082	1.98	2.08	L	.018	.024	0.46	0.61
A1	.001	.004	0.02	0.10	L1	.01 BSC		0.25 BSC	
A2	.077	.088	1.96	2.24	b1	.193	.199	4.90	5.06
D	.416	.424	10.57	10.77	c1	.007	.011	0.18	0.28
D1	.378	.382	9.60	9.70	e	2'	8'	2'	8'
D2	.290	-	7.37	-	aaa	.004		0.10	
D3	.016	.024	0.41	0.61					
E	.316	.324	8.03	8.23					
E1	.238	.242	6.04	6.15					
E2	.066	.074	1.68	1.88					
E3	.150	-	3.81	-					
E4	.058	.066	1.47	1.68					
E5	.231	.235	5.87	5.97					
© FREESCALE SEMICONDUCTOR, INC. ALL RIGHTS RESERVED.			MECHANICAL OUTLINE			PRINT VERSION NOT TO SCALE			
TITLE: TO-270 GULL WING					DOCUMENT NO: 98ASA99301D			REV: C	
					CASE NUMBER: 1265A-03			02 JUL 2007	
					STANDARD: JEDEC TO-270 BA				

PRODUCT DOCUMENTATION, SOFTWARE AND TOOLS

Refer to the following documents, software and tools to aid your design process.

Application Notes

- AN1907: Solder Reflow Attach Method for High Power RF Devices in Over-Molded Plastic Packages
- AN1955: Thermal Measurement Methodology of RF Power Amplifiers
- AN3263: Bolt Down Mounting Method for High Power RF Transistors and RFICs in Over-Molded Plastic Packages
- AN3789: Clamping of High Power RF Transistors and RFICs in Over-Molded Plastic Packages

Engineering Bulletins

- EB212: Using Data Sheet Impedances for RF LDMOS Devices

Software

- Electromigration MTTF Calculator
- RF High Power Model
- .s2p File

Development Tools

- Printed Circuit Boards

For Software and Tools, do a Part Number search at <http://www.freescale.com>, and select the "Part Number" link. Go to the Software & Tools tab on the part's Product Summary page to download the respective tool.

REVISION HISTORY

The following table summarizes revisions to this document.

Revision	Date	Description
0	June 2012	• Initial Release of Data Sheet

How to Reach Us:

Home Page:
freescale.com

Web Support:
freescale.com/support

Information in this document is provided solely to enable system and software implementers to use Freescale products. There are no express or implied copyright licenses granted hereunder to design or fabricate any integrated circuits based on the information in this document.

Freescale reserves the right to make changes without further notice to any products herein. Freescale makes no warranty, representation, or guarantee regarding the suitability of its products for any particular purpose, nor does Freescale assume any liability arising out of the application or use of any product or circuit, and specifically disclaims any and all liability, including without limitation consequential or incidental damages. "Typical" parameters that may be provided in Freescale data sheets and/or specifications can and do vary in different applications, and actual performance may vary over time. All operating parameters, including "typicals," must be validated for each customer application by customer's technical experts. Freescale does not convey any license under its patent rights nor the rights of others. Freescale sells products pursuant to standard terms and conditions of sale, which can be found at the following address: <http://www.reg.net/v2/webservices/Freescale/Docs/TermsandConditions.htm>.

Freescale, the Freescale logo, Altivec, C-5, CodeTest, CodeWarrior, ColdFire, C-Ware, Energy Efficient Solutions logo, Kinetis, mobileGT, PowerQUICC, Processor Expert, QorIQ, Qorivva, StarCore, Symphony, and VortiQa are trademarks of Freescale Semiconductor, Inc., Reg. U.S. Pat. & Tm. Off. Airfast, BeeKit, BeeStack, ColdFire+, CoreNet, Flexis, MagniV, MXC, Platform in a Package, QorIQ Qonverge, QUICC Engine, Ready Play, SafeAssure, SMARTMOS, TurboLink, Vybrid, and Xtrinsic are trademarks of Freescale Semiconductor, Inc. All other product or service names are the property of their respective owners.

© 2012 Freescale Semiconductor, Inc.