

<b>48Vin Input</b>	<b>28Vout Output</b>	<b>12.8Amp Current</b>	<b>2250Vdc Isolation</b>	<b>Half-brick DC/DC Converter</b>
------------------------	--------------------------	----------------------------	------------------------------	---------------------------------------

The PQ60280HEA13 PowerQor® Exa converter is an isolated, fixed switching frequency DC/DC converter that uses synchronous rectification and a patented topology to achieve extremely high efficiency and power density. This module is ideally suited to support wireless base station amplifiers and for applications to drive cooling fans used in networking systems, servers and data storage units. The Exa series converters offer industry leading useable output power for any standard “half-brick” module. The 28Vo modules are available in open frame and baseplated versions. RoHS compliant (see page 13).

### Operational Features

- Ultra-high efficiency, 94.5% at full rated load current, 94% at half rated load current
- Delivers up to 360 Watts of output power with minimal derating
- Input voltage range: 35V – 75V, with 100V for 100ms input transient capability
- Fixed frequency switching provides predictable EMI performance
- On-board input and output filtering

### Mechanical Features

- Industry standard half-brick pin-out configuration
- Industry standard size: 2.3" x 2.4" (58.4 x 61.0mm)
- Total height only 0.43" (10.8mm), baseplated unit only 0.50" (12.7mm)
- Total weight: 2.6 oz. (75 grams), baseplated unit 4.3oz. (123 grams)

### Control Features

- On/Off control referenced to input side (positive and negative logic options are available)
- Remote sense for the output voltage compensates for output distribution drops
- Output voltage trim permits custom voltages and voltage margining

### PQ60280HEA13 Module

### Protection Features

- Input under-voltage lockout disables converter at low input voltage conditions
- Output current limit and short circuit protection protects converter and load from damage
- Active back bias limit prevents damage to converter from external load induced pre-bias
- Output over-voltage protection
- Thermal shutdown

### Safety Features

- 2250V, 30 MΩ input-to-output isolation
- UL/cUL 60950-1 recognized (US & Canada), basic insulation rating
- TUV certified to EN60950-1
- Meets 72/23/EEC and 93/68/EEC directives
- Meets UL94V-0 flammability requirements



# Technical Specification

**Input: 35-75 V**  
**Output: 28 V**  
**Current: 12.8 A**  
**Package: Half-brick**

## MECHANICAL DIAGRAM (open frame)

Overall Height  
0.398+/-0.016  
(10.11+/-0.4)

### Side View

Bottom side  
Clearance  
See Note 10  
0.030+/-0.028  
(0.76+/-0.71)



Load Board

0.145  
(3.68)  
See Note 3

1.400 (35.56)  
 1.000 (25.40)  
 0.700 (17.78)  
 0.400 (10.16)  
 2.40 (61.00)

9 8 7 6 5

1.90 (48.30)  
 2.30 (58.40)

0.19 (4.80)

### Top View

1 2 4

0.50 (12.70)

0.400 (10.16)

1.400 (35.56)

## NOTES

- 1) Pins 1-4, 6-8 are 0.040" (1.02mm) diameter. with 0.080" (2.03mm) diameter standoff shoulders.
- 2) Pins 5 and 9 are 0.080" (2.03 mm) diameter with 0.125" (3.18mm) diameter standoff shoulders.
- 3) Other pin extension lengths available. Recommended pin length is 0.03" (0.76mm) greater than the PCB thickness.
- 4) All Pins: Material - Copper Alloy  
 Finish (RoHS 5/6) - Tin/Lead over Nickel plate  
 Finish (RoHS 6/6) - Matte Tin over Nickel plate
- 5) Undimensioned components are shown for visual reference only.
- 6) All dimensions in inches (mm)  
 Tolerances: x.xx +/-0.02 in. (x.x +/-0.5mm)  
 x.xxx +/-0.010 in. (x.xx +/-0.25mm)
- 7) Weight: 2.6 oz. (75g) typical
- 8) Workmanship: Meets or exceeds IPC-A-610C Class II
- 9) UL/TUV standards require a clearance greater than 0.04" (1.02mm) between input and output for Basic insulation. This issue should be considered if any copper traces are on the top side of the user's board. Note that the ferrite cores are considered part of the input/primary circuit.

## PIN DESIGNATIONS

Pin No.	Name	Function
1	Vin(+)	Positive input voltage
2	ON/OFF	TTL input to turn converter on and off, referenced to Vin(-), with internal pull up.
4	Vin(-)	Negative input voltage
5	Vout(-)	Negative output voltage
6	SENSE(-)	Return remote sense
7	TRIM	Output voltage trim
8	SENSE(+)	Positive remote sense
9	Vout(+)	Positive output voltage

### Notes:

1. SENSE(-) may be connected to Vout(-) either remotely or at the converter.
2. Leave TRIM pin open for nominal output voltage.
3. SENSE(+) may be connected to Vout(+) either remotely or at the converter.



# Technical Specification

**Input: 35-75 V**  
**Output: 28 V**  
**Current: 12.8 A**  
**Package: Half-brick**

## MECHANICAL DIAGRAM (base-plated)

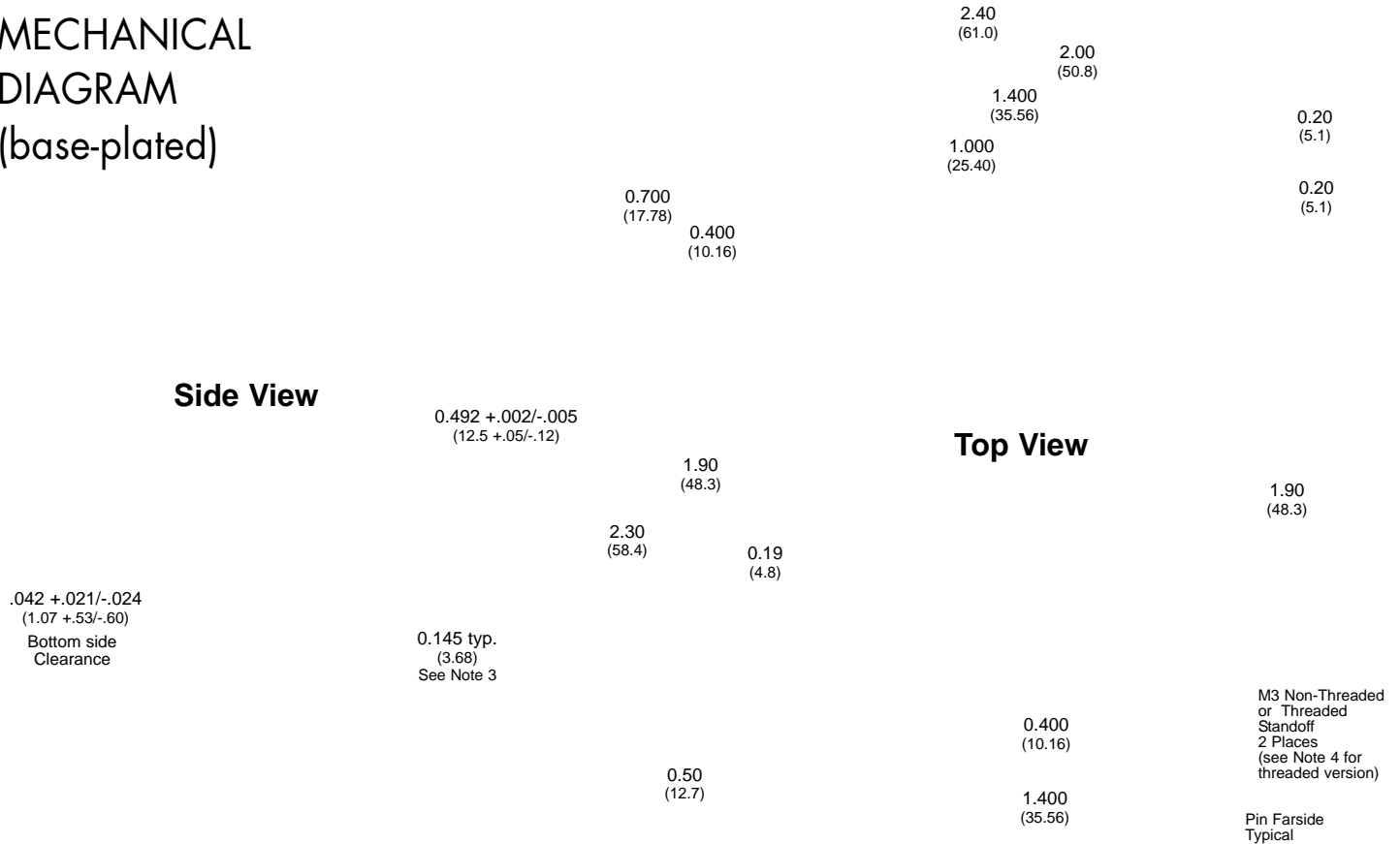

## NOTES

- 1) Pins 1-4, 6-8, A, B are 0.040" (1.02mm) diameter with 0.080" (2.03mm) diameter standoff shoulders.
- 2) Pins 5 and 9 are 0.080" (2.03 mm) diameter with 0.125" (3.18mm) diameter standoff shoulders.
- 3) Other pin extension lengths available. Recommended pin length is 0.03" (0.76mm) greater than the PCB thickness.
- 4) Applied torque per screw should not exceed 3 in-lb (.33Nm)
- 5) Baseplate flatness tolerance is 0.004" (0.10mm) TIR for surface.
- 6) All Pins: Material - Copper Alloy  
 Finish (RoHS 5/6) - Tin/Lead over Nickel plate  
 Finish (RoHS 6/6) - Matte Tin over Nickel plate
- 7) Undimensioned components are shown for visual reference only.
- 8) All dimensions in inches (mm)  
 Tolerances: x.xx +/-0.02 in. (x.x +/-0.5mm)  
 x.xxx +/-0.010 in. (x.xx +/-0.25mm)
- 9) Weight: 4.3 oz. (123g) typical
- 10) Workmanship: Meets or exceeds IPC-A-610C Class II

## PIN DESIGNATIONS

Pin No.	Name	Function
1	Vin(+)	Positive input voltage
2	ON/OFF	TTL input to turn converter on and off, referenced to Vin(-), with internal pull up.
4	Vin(-)	Negative input voltage
5	Vout(-)	Negative output voltage
6	SENSE(-)	Return remote sense
7	TRIM	Output voltage trim
8	SENSE(+)	Positive remote sense
9	Vout(+)	Positive output voltage

### Notes:

1. SENSE(-) may be connected to Vout(-) either remotely or at the converter.
2. Leave TRIM pin open for nominal output voltage.
3. SENSE(+) may be connected to Vout(+) either remotely or at the converter.



**Input: 35-75 V**  
**Output: 28 V**  
**Current: 12.8 A**  
**Package: Half-brick**

## Technical Specification

### PQ60280HEA13 ELECTRICAL CHARACTERISTICS

$T_A=25^{\circ}\text{C}$ , airflow rate=300 LFM,  $V_{in}=48\text{Vdc}$  unless otherwise noted; full operating temperature range is  $-40^{\circ}\text{C}$  to  $+100^{\circ}\text{C}$  ambient temperature with appropriate power derating. Specifications subject to change without notice.

Parameter	Min.	Typ.	Max.	Units	Notes & Conditions
<b>ABSOLUTE MAXIMUM RATINGS</b>					
Input Voltage					
Non-Operating			100	V	Continuous
Operating			80	V	Continuous
Operating Transient Protection			100	V	100 $\mu\text{s}$ transient
Isolation Voltage (input to output)			2250	V	Basic insulation level, Pollution degree 2
Operating Temperature	-40		100	$^{\circ}\text{C}$	
Storage Temperature	-55		125	$^{\circ}\text{C}$	
Voltage at ON/OFF input pin	-2		18	V	
<b>INPUT CHARACTERISTICS</b>					
Operating Input Voltage Range	35	48	75	V	
Input Under-Voltage Lockout					
Turn-On Voltage Threshold	32.3	33.6	34.6	V	
Turn-Off Voltage Threshold	29.6	30.6	31.8	V	
Lockout Voltage Hysteresis		3.0		V	
Maximum Input Current			11.0	A	100% Load, 35 $V_{in}$
No-Load Input Current		180	250	mA	
Disabled Input Current		39	60	mA	
Inrush Current Transient Rating			0.05	$\text{A}^2\text{s}$	
Input Reflected Ripple Current			40	mA	RMS thru 4.7 $\mu\text{H}$ inductor; Figures 13 & 15
Input Terminal Ripple Current		120		mA	RMS; Figures 13 & 14
Recommended Input Fuse			20	A	Fast blow external fuse recommended
Input Filter Component Values (L\C)		1.0 \ 5.0		$\mu\text{H}\backslash\mu\text{F}$	Internal values; Figure E
Recommended External Input Capacitance		100		$\mu\text{F}$	Typical ESR 0.2 $\Omega$ ; see Figure 13
Recommended External Input Capacitor ESR1	0.04	0.20	1.00	$\Omega$	100kHz, $-40^{\circ}\text{C}$ to $100^{\circ}\text{C}$
<b>OUTPUT CHARACTERISTICS</b>					
Output Voltage Set Point	27.75	28.00	28.25	V	
Output Voltage Regulation					
Over Line		$\pm 0.05 \backslash 28$	$\pm 0.10 \backslash 28$	%\mV	
Over Load		$\pm 0.1 \backslash 28$	$\pm 0.2 \backslash 56$	%\mV	
Over Temperature		$\pm 45$	$\pm 90$	mV	
Total Output Voltage Range	27.50		28.50	V	Over sample, line, load, temperature & life
Output Voltage Ripple and Noise <sup>1</sup>					20MHz bandwidth; Figures 13 & 16
Peak-to-Peak		150	200	mV	Full Load; Figures 13 & 16
RMS		30	50	mV	Full Load; Figures 13 & 16
Operating Output Current Range	0.0		12.8	A	Subject to thermal derating; Figures 5 - 8
Output DC Current-Limit Inception	14.7	15.8	17.0	A	Output Voltage 10% Low; Figure 25
Back-Drive Current-Limit While Enabled	0.5	1.0	2.0	A	Negative current drawn from output
Back-Drive Current-Limit While Disabled	0.14	0.20	0.30	A	Negative current drawn from output
Maximum Output Capacitance			4,000	$\mu\text{F}$	28Vout at 12.8A Resistive Load
<b>DYNAMIC CHARACTERISTICS</b>					
Input Voltage Ripple Rejection		30		dB	120 Hz; Figure 20
Output Voltage during Load Current Transient					
For a Step Change in Output Current (0.1A/ $\mu\text{s}$ )		500		mV	50-75-50% lout max; 330 $\mu\text{F}$ cap; Figure 11
For a Step Change in Output Current (5A/ $\mu\text{s}$ )		500		mV	50-75-50% lout max; 330 $\mu\text{F}$ cap; Figure 12
Settling Time		200		$\mu\text{s}$	To within 1% Vout nom
Turn-On Transient					
Turn-On Time	10	19	26	ms	Full load, Vout=90% nom.; Figures 9 & 10
Start-Up Inhibit Time	2	4	6	ms	$-40^{\circ}\text{C}$ to $+125^{\circ}\text{C}$ ; Figure A
Output Voltage Overshoot		0		%	4,000 $\mu\text{F}$ load capacitance, lout = 12.8A resistive load
<b>EFFICIENCY</b>					
100% Load		94.5		%	Figures 1 - 4 (Figure 23 for baseplated)
50% Load		94.0		%	Figures 1 - 4 (Figure 23 for baseplated)
<b>TEMPERATURE LIMITS FOR POWER DERATING CURVES</b>					
Semiconductor Junction Temperature			125	$^{\circ}\text{C}$	Package rated to $150^{\circ}\text{C}$
Board Temperature			125	$^{\circ}\text{C}$	UL rated max operating temp $130^{\circ}\text{C}$
Transformer Temperature			125	$^{\circ}\text{C}$	See Figures 5 - 8 for derating curves
Maximum Baseplate Temperature <sup>2</sup>			100	$^{\circ}\text{C}$	Applies to baseplated units only
<b>ISOLATION CHARACTERISTICS</b>					
Isolation Voltage (dielectric strength)		2250		V	
Isolation Resistance		30		$\text{M}\Omega$	
Isolation Capacitance <sup>3</sup>		220		pF	

Note 1: For applications requiring reduced output voltage ripple and noise, consult SynQor applications support (e-mail: [support@synqor.com](mailto:support@synqor.com))

Note 2: There is no derating with a baseplate temperature of  $100^{\circ}\text{C}$  or lower.

Note 3: Higher values of isolation capacitance can be added external to the module.



**Input: 35-75 V**  
**Output: 28 V**  
**Current: 12.8 A**  
**Package: Half-brick**

## Technical Specification

### ELECTRICAL CHARACTERISTICS (Continued)

Parameter	Min.	Typ.	Max.	Units	Notes & Conditions
<b>FEATURE CHARACTERISTICS</b>					
Switching Frequency	275	290	305	kHz	Regulation and Isolation stages
ON/OFF Control (Option P)					
Off-State Voltage	-2		0.8	V	
On-State Voltage	2.7		18	V	
ON/OFF Control (Option N)					
Off-State Voltage	2.7		18	V	
On-State Voltage	-2		0.8	V	
ON/OFF Control (Either Option)					Figure A
Pull-Up Voltage		5	5.5	V	
Pull-Up Resistance		10		kΩ	
Feature Set S					
Output Voltage Trim Range	-50		+10	%	Measured across Pins 9 & 5; Figure C
Output Voltage Remote Sense Range			+10	%	Measured across Pins 9 & 5
Output Over-Voltage Protection	111.0	117.0	123.0	%	Over full temp range; % of nominal Vout
Feature Set H					
Output Voltage Trim Range	-50		+15	%	Measured across Pins 9 & 5; Figure C
Output Voltage Remote Sense Range			+15	%	Measured across Pins 9 & 5
Output Over-Voltage Protection	34.4	35.9	37.5	V	Over full temp range
Over-Temperature Shutdown		120		°C	Average PCB Temperature
Over-Temperature Shutdown Restart Hysteresis		10		°C	
Load Current Scale Factor		400			See App Note: Output Load Current Calc.
<b>RELIABILITY CHARACTERISTICS</b>					
Calculated MTBF (Telcordia)		1.9		10 <sup>6</sup> Hrs.	TR-NWT-000332; 80% load, 300LFM, 40°C T <sub>a</sub>
Calculated MTBF (MIL-217)		1.4		10 <sup>6</sup> Hrs.	MIL-HDBK-217F; 80% load, 300LFM, 40°C T <sub>a</sub>
Field Demonstrated MTBF				10 <sup>6</sup> Hrs.	See our <a href="#">website</a> for details

### STANDARDS COMPLIANCE

Parameter	Notes
<b>STANDARDS COMPLIANCE</b>	
UL/cUL 60950-1	File # E194341, Basic insulation & pollution degree 2
EN60950-1	Certified by TÜV
72/23/EEC	
93/68/EEC	
Needle Flame Test (IEC 695-2-2)	Test on entire assembly; board & plastic components UL94V-0 compliant
IEC 61000-4-2	ESD test, 8kV - NP, 15kV air - NP (Normal Performance)
GR-1089-CORE	Section 7 - electrical safety, Section 9 - bonding/grounding
Telcordia (Bellcore) GR-513	

- An external input fuse must always be used to meet these safety requirements. Contact SynQor for official safety certificates on new releases or download from the [SynQor website](#).

### QUALIFICATION TESTING

Parameter	# Units	Test Conditions
<b>QUALIFICATION TESTING</b>		
Life Test	32	95% rated V <sub>in</sub> and load, units at derating point, 1000 hours
Vibration	5	10-55Hz sweep, 0.060" total excursion, 1 min./sweep, 120 sweeps for 3 axis
Mechanical Shock	5	100g minimum, 2 drops in x and y axis, 1 drop in z axis
Temperature Cycling	10	-40°C to 100°C, unit temp. ramp 15°C/min., 500 cycles
Power/Thermal Cycling	5	T <sub>operating</sub> = min to max, V <sub>in</sub> = min to max, full load, 100 cycles
Design Marginality	5	T <sub>min</sub> -10°C to T <sub>max</sub> +10°C, 5°C steps, V <sub>in</sub> = min to max, 0-105% load
Humidity	5	85°C, 85% RH, 1000 hours, 2 minutes on and 6 hours off
Solderability	15 pins	MIL-STD-883, method 2003

- Extensive characterization testing of all SynQor products and manufacturing processes is performed to ensure that we supply robust, reliable product. Contact the factory for official product family qualification documents.

### OPTIONS

SynQor provides various options for Logic Sense, Pin Length and Feature Set for this family of DC/DC converters. Please consult the [last page](#) for information on available options.

### PATENTS

SynQor is protected under various patents. Please refer to the [last page](#) for further information.



# Technical Specification

**Input: 35-75 V**  
**Output: 28 V**  
**Current: 12.8 A**  
**Package: Half-brick**

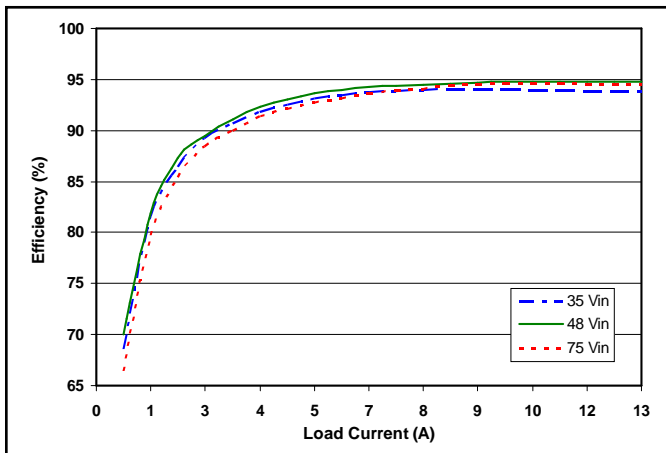

**Figure 1:** Efficiency at nominal output voltage vs. load current for minimum, nominal, and maximum input voltage at 25°C.

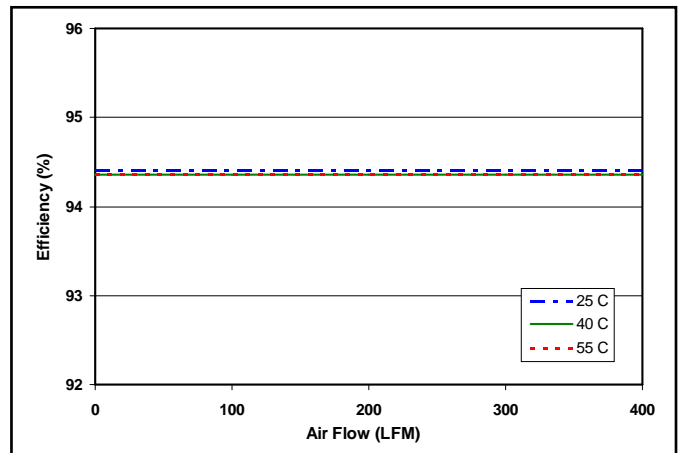

**Figure 2:** Efficiency at nominal output voltage and 60% rated power vs. airflow rate for ambient air temperatures of 25°C, 40°C, and 55°C (nominal input voltage).

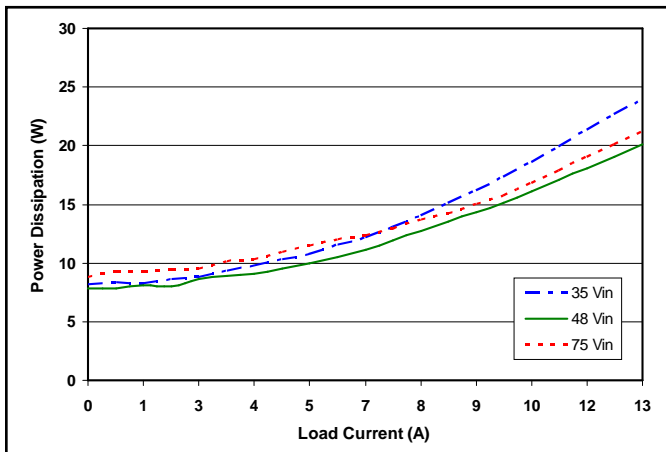

**Figure 3:** Power dissipation at nominal output voltage vs. load current for minimum, nominal, and maximum input voltage at 25°C.

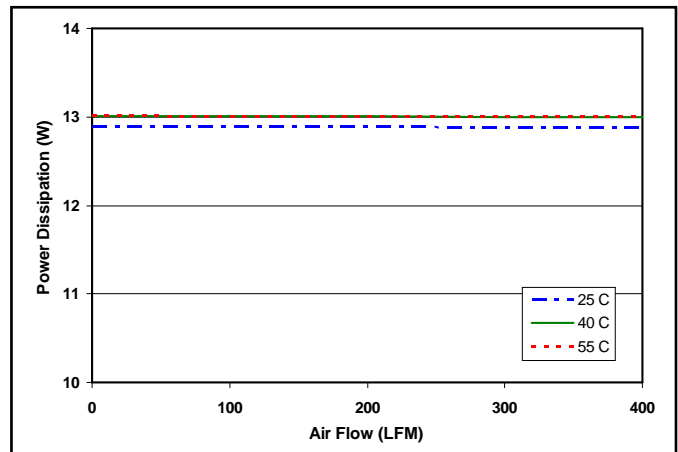

**Figure 4:** Power dissipation at nominal output voltage and 60% rated power vs. airflow rate for ambient air temperatures of 25°C, 40°C, and 55°C (nominal input voltage).

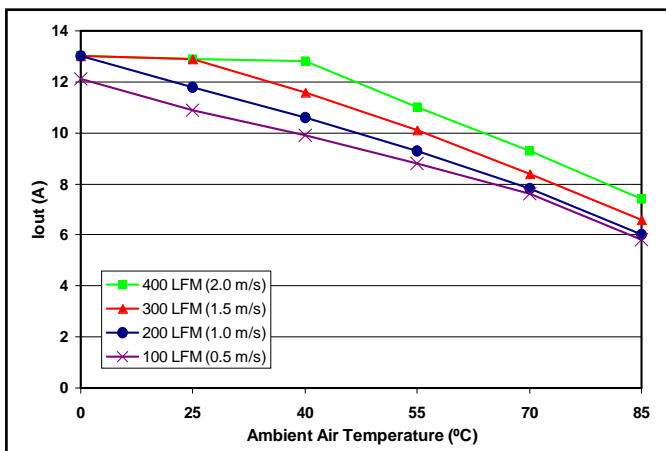

**Figure 5:** Maximum output power derating curves vs. ambient air temperature for airflow rates of 100 LFM through 400 LFM with air flowing from pin 4 to pin 1 (nominal input voltage). See Figure 23 for baseplate derating curve.



**Figure 6:** Thermal plot of converter at 9.3 amp load current (260.4W) with 55°C air flowing at the rate of 200 LFM. Air is flowing from pin 4 to pin 1 (nominal input voltage).

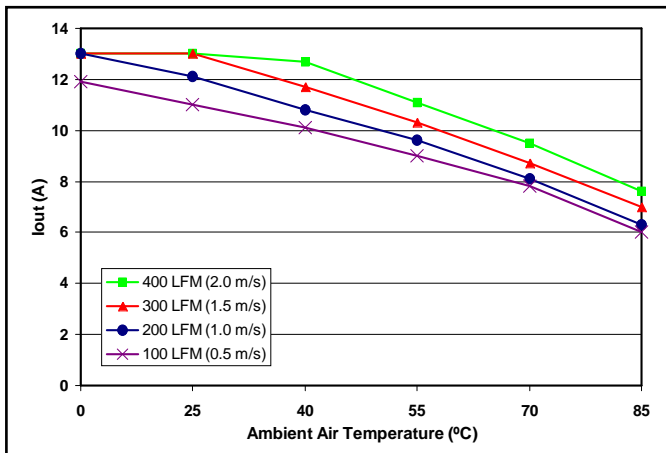

**Figure 7:** Maximum output power derating curves vs. ambient air temperature for airflow rates of 100 LFM through 400 LFM with air flowing from input to output (nominal input voltage). See Figure 23 for baseplate derating curve.

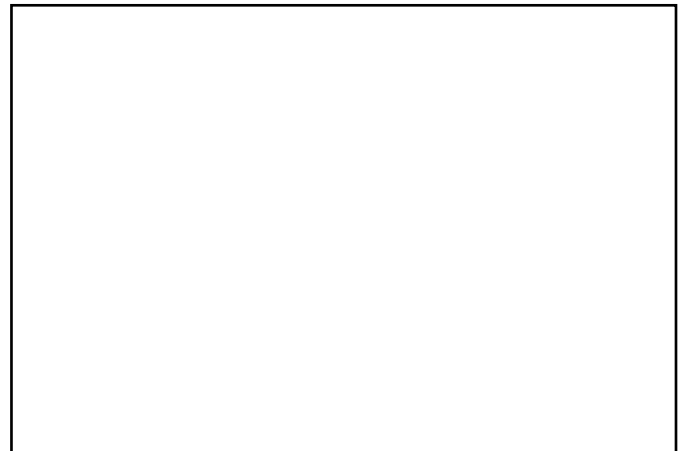

**Figure 8:** Thermal plot of converter at 9.6 amp load current (268.8W) with 55°C air flowing at the rate of 200 LFM. Air is flowing across the converter from input to output (nominal input voltage).

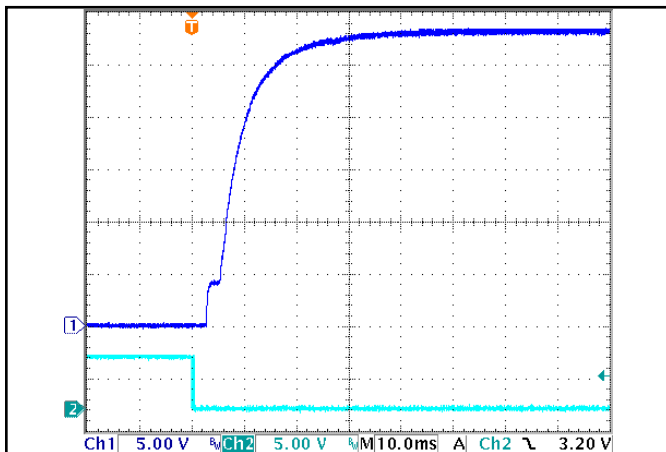

**Figure 9:** Turn-on transient at full load (resistive load) (10 ms/div). Input voltage pre-applied. Top Trace: V<sub>out</sub> (5V/div). Bottom Trace: ON/OFF input (5V/div)

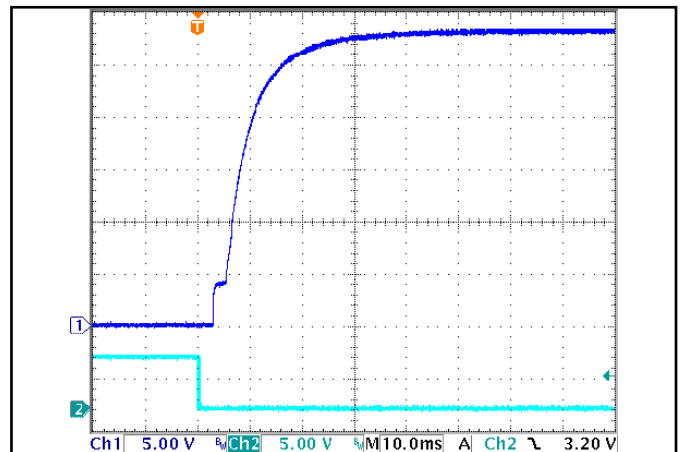

**Figure 10:** Turn-on transient at zero load (10 ms/div). Top Trace: V<sub>out</sub> (5V/div). Bottom Trace: ON/OFF input (5V/div)

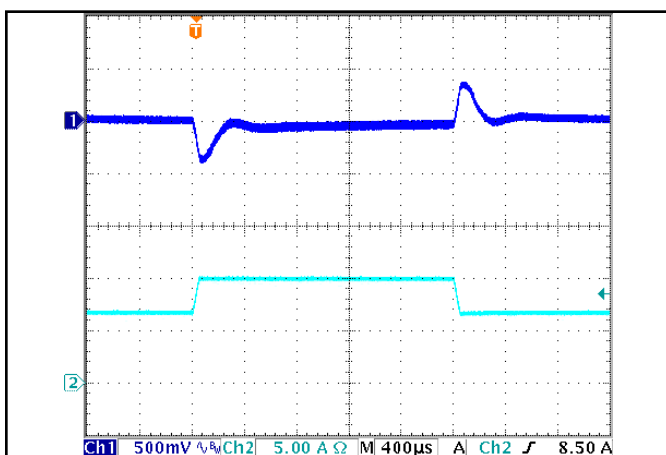

**Figure 11:** Output voltage response to step-change in load current (50%-75%-50% of I<sub>out</sub>(max); dI/dt = 0.1A/μs). Load cap: 330μF, electrolytic output capacitance. Top trace: V<sub>out</sub> (500mV/div). Bottom trace: I<sub>out</sub> (5A/div).

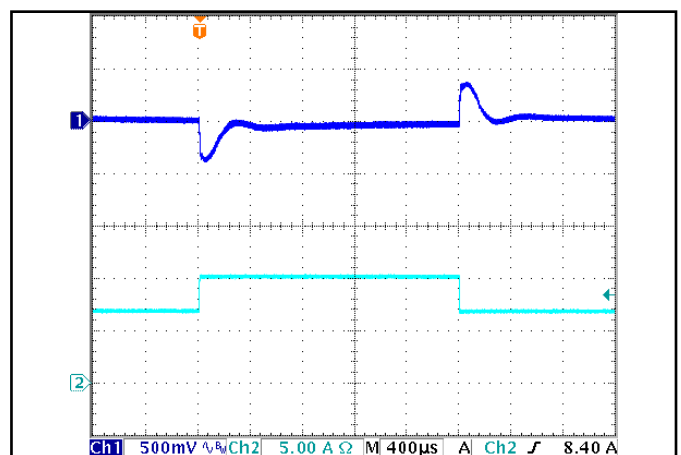

**Figure 12:** Output voltage response to step-change in load current (50%-75%-50% of I<sub>out</sub>(max); dI/dt = 5A/μs). Load cap: 330μF, electrolytic output capacitance. Top trace: V<sub>out</sub> (500mV/div). Bottom trace: I<sub>out</sub> (5A/div).

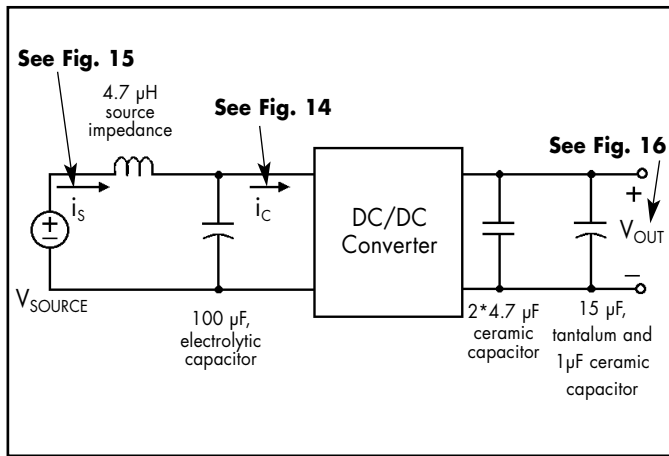

**Figure 13:** Test set-up diagram showing measurement points for Input Terminal Ripple Current (Figure 14), Input Reflected Ripple Current (Figure 15) and Output Voltage Ripple (Figure 16).

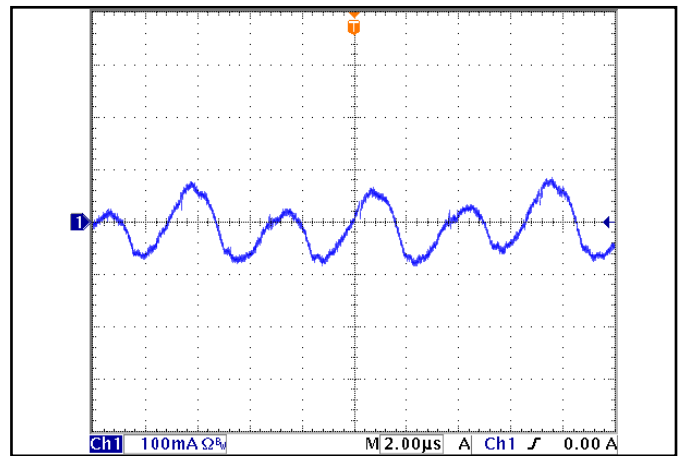

**Figure 14:** Input Terminal Ripple Current,  $i_c$ , at full rated output current and nominal input voltage with  $4.7 \mu\text{H}$  source impedance and  $100 \mu\text{F}$  electrolytic capacitor (100 mA/div). (See Figure 13)

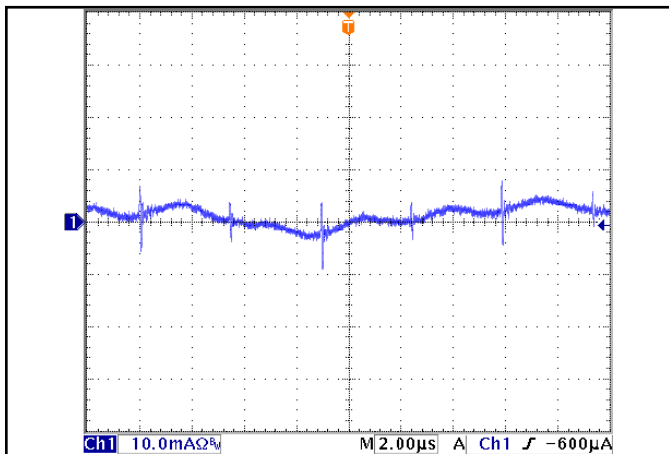

**Figure 15:** Input reflected ripple current,  $i_s$ , through a  $10 \mu\text{H}$  source inductor at nominal input voltage and rated load current (10 mA/div). (See Figure 13)

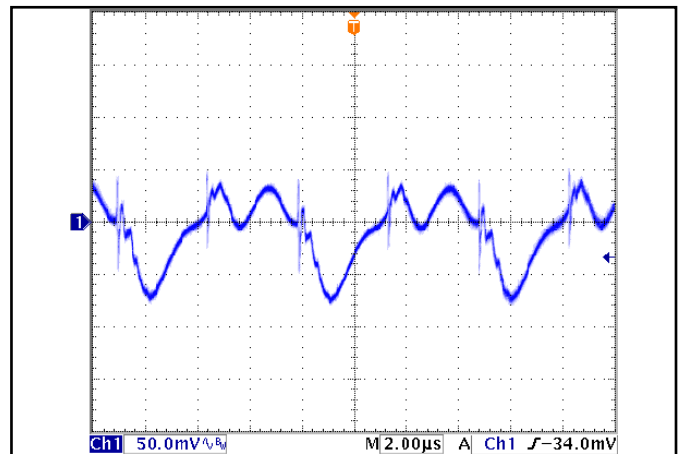

**Figure 16:** Output voltage ripple at nominal input voltage and rated load current (50 mV/div). Load capacitance: two  $4.7 \mu\text{F}$  ceramic capacitors and  $15 \mu\text{F}$  tantalum capacitor. Bandwidth: 20 MHz. (See Figure 13)

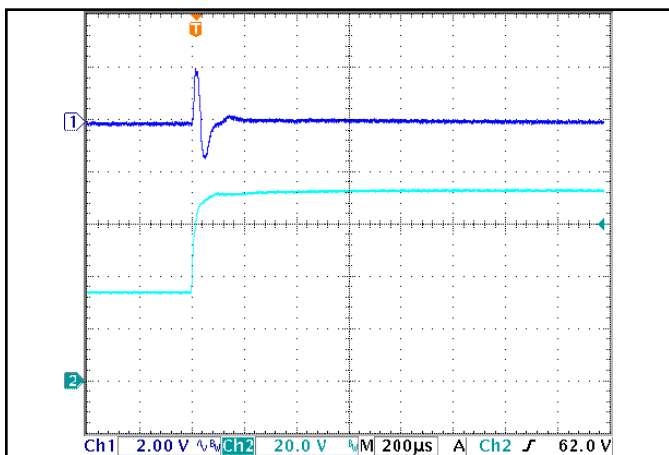

**Figure 17:** Output voltage response to step-change in input voltage (1000V/ms). Load cap:  $330 \mu\text{F}$ , electrolytic output capacitance. Ch 1:  $V_{out}$  (2V/div), Ch 2:  $V_{in}$  (20V/div).

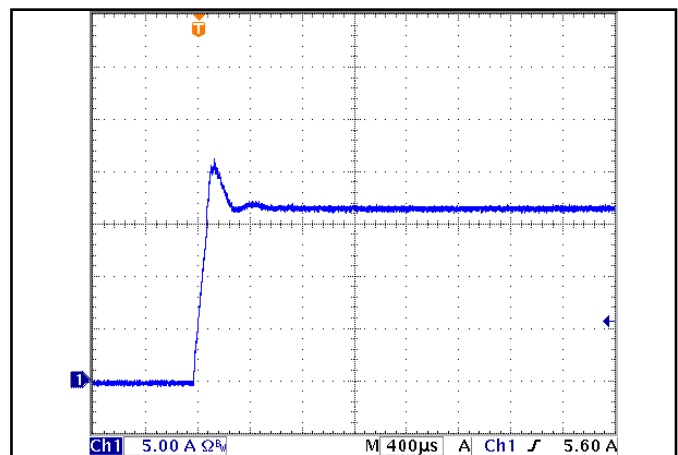

**Figure 18:** Load current (5A/div) as a function of time when the converter attempts to turn on into a  $10 \text{ m}\Omega$  short circuit.

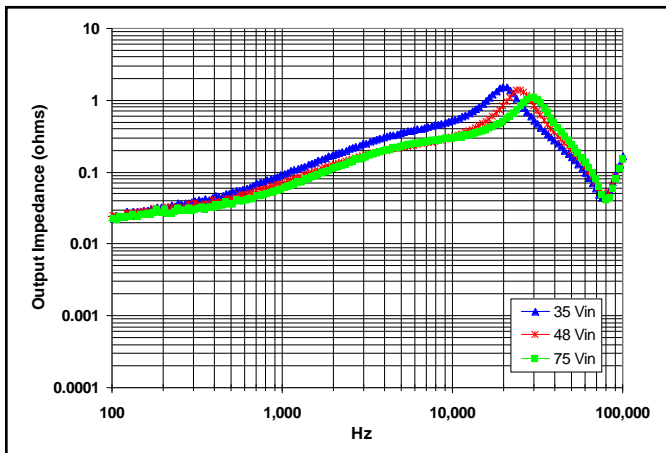

**Figure 19:** Magnitude of incremental output impedance ( $Z_{out} = v_{out}/i_{out}$ ) for minimum, nominal, and maximum input voltage at full rated power.

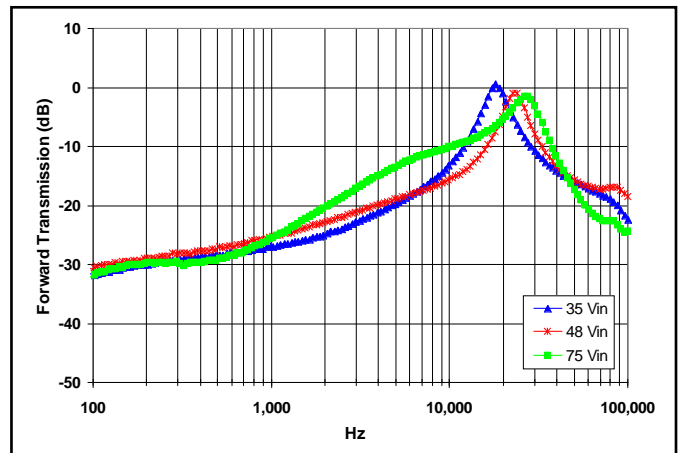

**Figure 20:** Magnitude of incremental forward transmission ( $FT = v_{out}/v_{in}$ ) for minimum, nominal, and maximum input voltage at full rated power.

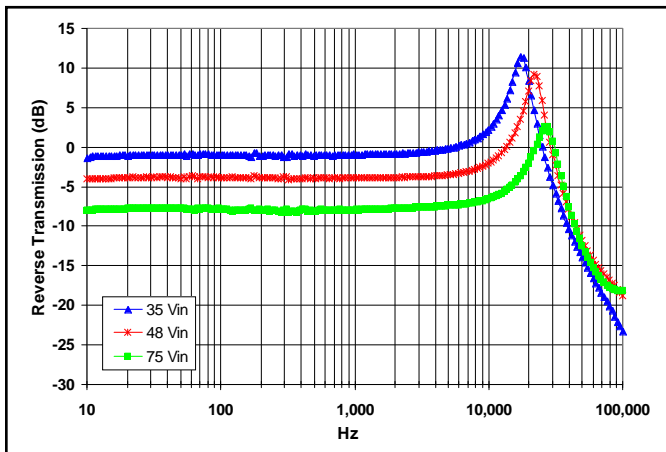

**Figure 21:** Magnitude of incremental reverse transmission ( $RT = i_{in}/i_{out}$ ) for minimum, nominal, and maximum input voltage at full rated power.

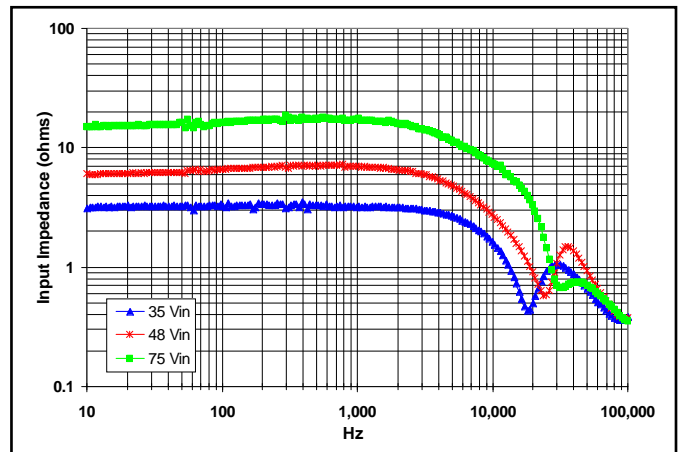

**Figure 22:** Magnitude of incremental input impedance ( $Z_{in} = v_{in}/i_{in}$ ) for minimum, nominal, and maximum input voltage at full rated power.

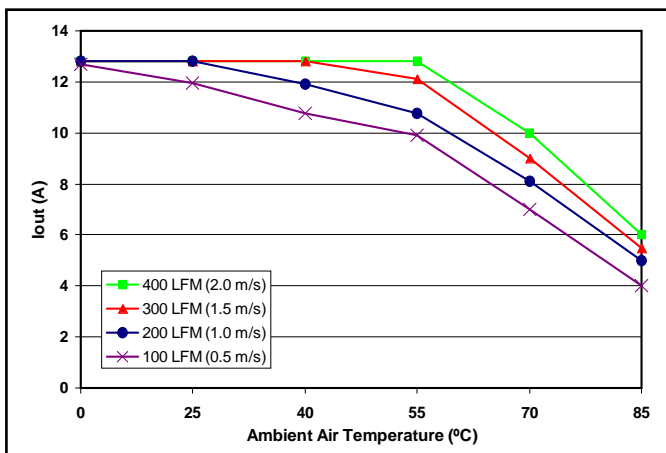

**Figure 23:** Baseplated unit maximum output power derating curves vs. ambient air temperature for airflow rates of 100 LFM through 400 LFM with air flowing from input to output (nominal input voltage). No derating if baseplate is  $\leq 100^{\circ}\text{C}$ .

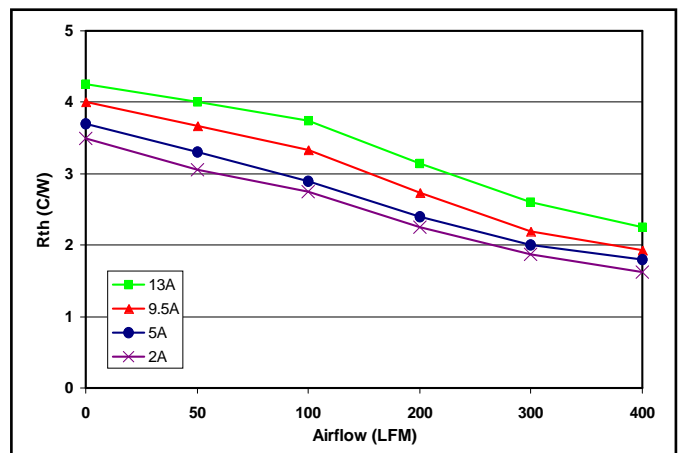

**Figure 24:** Thermal resistance.



# Technical Specification

**Input:** 35-75 V  
**Output:** 28 V  
**Current:** 12.8 A  
**Package:** Half-brick

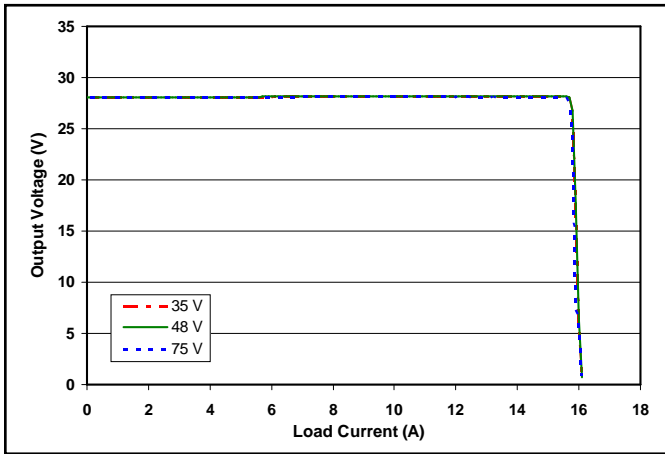

Figure 25: Output voltage vs. load current showing typical current limit curves and converter shutdown points.

## Technical Specification

### BASIC OPERATION AND FEATURES

The PowerQor series converter uses a two-stage power conversion topology. The first stage keeps the output voltage constant over variations in line, load, and temperature. The second stage uses a transformer to provide the functions of input/output isolation and voltage step-down to achieve the low output voltage required.

Both the first stage and the second stage switch at a fixed frequency for predictable EMI performance. Rectification of the transformer's output is accomplished with synchronous rectifiers. These devices, which are MOSFETs with a very low on-state resistance, dissipate far less energy than Schottky diodes. This is the primary reason that the PowerQor converter has such high efficiency, even at very low output voltages and very high output currents.

Dissipation throughout the converter is so low that it does not require a heatsink for operation. Since a heatsink is not required, the PowerQor converter does not need a metal baseplate or potting material to help conduct the dissipated energy to the heatsink. The PowerQor converter can thus be built more simply and reliably using high yield surface mount techniques on a PCB substrate.

The PowerQor series of half-brick and quarter-brick converters uses the industry standard footprint and pin-out configuration.

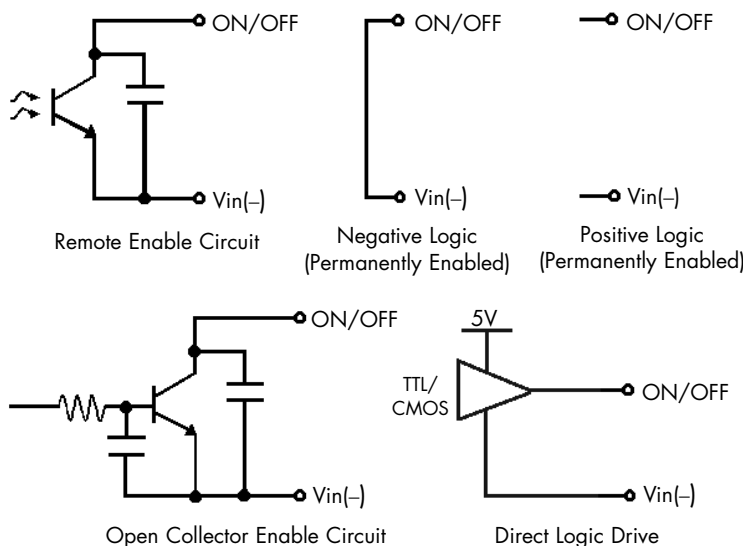

Figure A: Various circuits for driving the ON/OFF pin.

### CONTROL FEATURES

**REMOTE ON/OFF (Pin 2):** The ON/OFF input, Pin 2, permits the user to control when the converter is on or off. This input is referenced to the return terminal of the input bus, Vin(-). There are two versions of the converter that differ by the sense of the logic used for the ON/OFF input.

In the positive logic version, the ON/OFF input is active high (meaning that a high turns the converter on). In the negative logic version, the ON/OFF signal is active low (meaning that a low turns the converter on). Figure A details five possible circuits for driving the ON/OFF pin.

**REMOTE SENSE(+)** (Pins 8 and 6): The SENSE(±) inputs correct for voltage drops along the conductors that connect the converter's output pins to the load.

Pin 8 should be connected to Vout(+) and Pin 6 should be connected to Vout(-) at the point on the board where regulation is desired. A remote connection at the load can adjust for a voltage drop only as large as that specified in this datasheet, that is

Pins 8 and 6 must be connected for proper regulation of the output voltage. If these connections are not made, the converter will deliver an output voltage that is slightly higher than its specified value.

**Note:** the output over-voltage protection circuit senses the voltage across the output (pins 9 and 5) to determine when it should trigger, not the voltage across the converter's sense leads (pins 8 and 6). Therefore, the resistive drop on the board should be small enough so that output OVP does not trigger, even during load transients.

**OUTPUT VOLTAGE TRIM (Pin 7):** The TRIM input permits the user to adjust the output voltage across the sense leads up or down according to the trim range specifications.

To decrease the output voltage, the user should connect a resistor between Pin 7 and Pin 6 (SENSE(-) input). For a desired decrease of the nominal output voltage, the value of the resistor should be

$$R_{\text{trim-down}} = \left( \frac{100\%}{\Delta} \right) - 2 \text{ (k}\Omega\text{)}$$

where

$$\Delta\% = \left| \frac{V_{\text{nominal}} - V_{\text{desired}}}{V_{\text{nominal}}} \right| \times 100\%$$

## Technical Specification

To increase the output voltage, the user should connect a resistor between Pin 7 and Pin 8 (SENSE(+) input). For a desired increase of the nominal output voltage, the value of the resistor should be

$$R_{\text{trim-up}} = \frac{\left(\frac{V_{\text{nominal}}}{1.225} - 2\right) \times V_{\text{DES}} + V_{\text{NOM}}}{V_{\text{DES}} - V_{\text{NOM}}} \quad (\text{k}\Omega)$$

Figure C graphs the relationship between the trim resistor value and Rtrim-up and Rtrim-down, showing the total range the output voltage can be trimmed up or down.

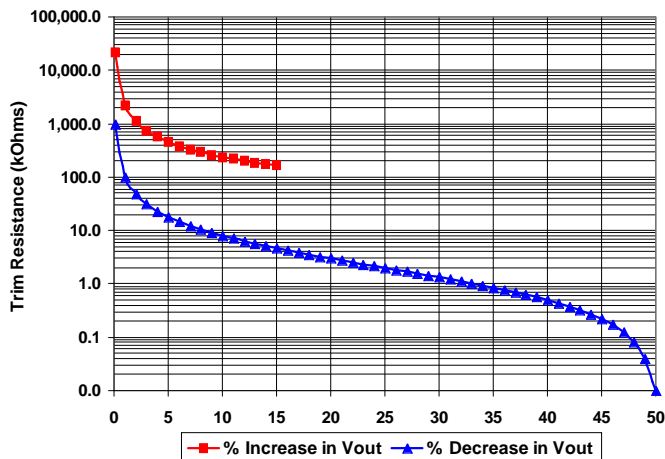

Figure C: Trim Graph for 28Vout module

**Note:** the TRIM feature does not affect the voltage at which the output over-voltage protection circuit is triggered. Trimming the output voltage too high may cause the over-voltage protection circuit to engage, particularly during transients.

It is not necessary for the user to add capacitance at the Trim pin. The node is internally bypassed to eliminate noise.

**Total DC Variation of Vout:** For the converter to meet its full specifications, the maximum variation of the DC value of Vout, due to both trimming and remote load voltage drops, should not be greater than that specified for the output voltage trim range.

## PROTECTION FEATURES

**Input Under-Voltage Lockout:** The converter is designed to turn off when the input voltage is too low, helping avoid an input system instability problem, described in more detail in the application note titled "Input System Instability". The lockout circuitry is a comparator with DC hysteresis. When the input voltage is rising, it must exceed the typical "Turn-On Voltage Threshold"

value\* before the converter will turn on. Once the converter is on, the input voltage must fall below the typical Turn-Off Voltage Threshold value before the converter will turn off.

**Output Current Limit:** If the output current exceeds the "Output DC Current Limit Inception" point\*, then a fast linear current limit controller will reduce the output voltage to maintain a constant output current. There is no minimum operating output voltage. The converter will run with low on-board power dissipation down to zero output voltage. A redundant circuit will shut-down the converter if the primary current limit fails.

**Back-Drive Current Limit:** If there is negative output current of a magnitude larger than the "Back-Drive Current Limit while Enabled" specification\*, then a fast back-drive limit controller will increase the output voltage to maintain a constant output current. If this results in the output voltage exceeding the "Output Over-Voltage Protection" threshold\*, then the unit will shut down. The full I-V output characteristic can be seen in Figure 19.

**Output Over-Voltage Limit:** If the voltage across the output pins exceeds the "Output Over-Voltage Protection" threshold\*, the converter will immediately stop switching. This prevents damage to the load circuit due to 1) excessive series resistance in output current path from converter output pins to sense point, 2) a release of a short-circuit condition, or 3) a release of a current limit condition. Load capacitance determines exactly how high the output voltage will rise in response to these conditions.

**Over-Temperature Shutdown:** A temperature sensor on the converter senses the average temperature of the module. The thermal shutdown circuit is designed to turn the converter off when the temperature at the sensed location reaches the Over-Temperature Shutdown value. It will allow the converter to turn on again when the temperature of the sensed location falls by the amount of the Over-Temperature Shutdown Restart Hysteresis value.

**Start-up Inhibit Period:** If any protection feature causes the converter to shut down, the converter will attempt to restart after 2ms (typical), the "Startup Inhibit Period".\* On initial application of input voltage, with the on/off pin set to enable the converter, the "Turn-On Time"\* will increase by only 2ms.

\* See [specifications page](#) for details.

## Technical Specification

### APPLICATION CONSIDERATIONS

**Input System Instability:** This condition can occur because any DC/DC converter appears incrementally as a negative resistance load. A detailed application note titled "Input System Instability" is available on the SynQor website which provides an understanding of why this instability arises, and shows the preferred solution for correcting it.

**Application Circuits:** Figure D below provides a typical circuit diagram which details the input filtering and voltage trimming.

**Input Filtering and External Input Capacitance:** Figure E below shows the internal input filter components. This filter dramatically reduces input terminal ripple current, which otherwise could exceed the rating of an external electrolytic input capacitor. The recommended external input capacitance is specified in the "Input Characteristics" section on the [Electrical Specifications page](#). More detailed information is available in the application note titled "EMI Characteristics" on the [SynQor website](#).

### Output Filtering and External Output Capacitance:

Figure E below shows the internal output filter components. This filter dramatically reduces output voltage ripple. However, some minimum external output capacitance is required, as specified in the Output Characteristics section on the [Electrical Specifications page](#). No damage will occur without this capacitor connected, but peak output voltage ripple will be much higher.

**RoHS Compliance:** The EU led RoHS (Restriction of Hazardous Substances) Directive bans the use of Lead, Cadmium, Hexavalent Chromium, Mercury, Polybrominated Biphenyls (PBB), and Polybrominated Diphenyl Ether (PBDE) in Electrical and Electronic Equipment. This SynQor product is available as 5/6 RoHS compliant (product with lead) or 6/6 RoHS compliant. For more information please refer to SynQor's RoHS addendum available at our [RoHS Compliance / Lead Free Initiative](#) web page or e-mail us at [rohs@synqor.com](mailto:rohs@synqor.com).

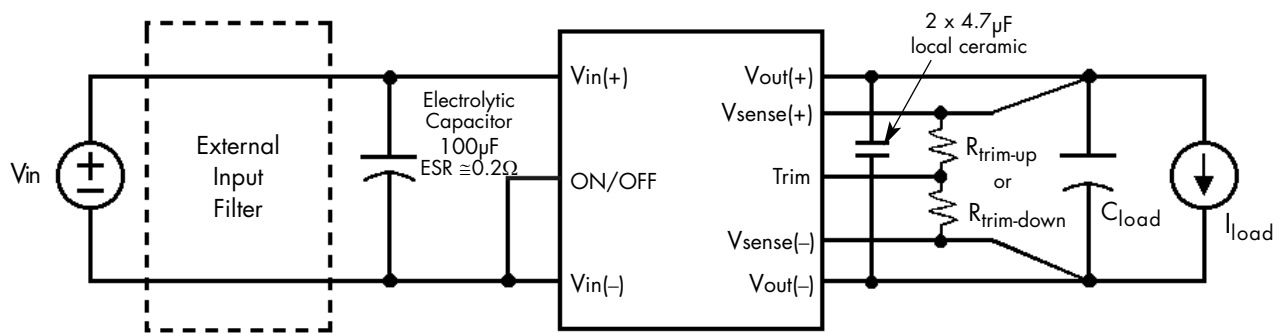

Figure D: Typical application circuit (negative logic unit, permanently enabled).

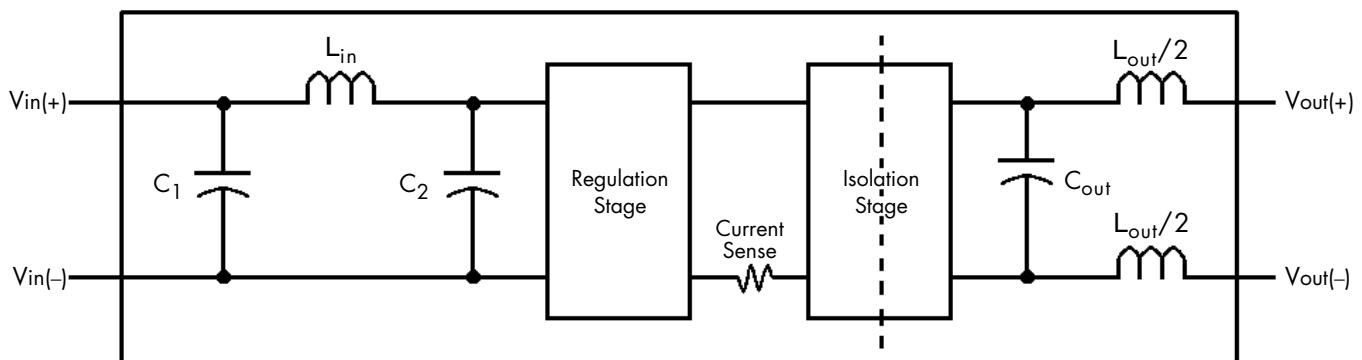

Figure E: Internal Input and Output Filter Diagram (component values listed on [specifications page](#)).



**Input: 35-75 V**  
**Output: 28 V**  
**Current: 12.8 A**  
**Package: Half-brick**

## Technical Specification

### PART NUMBERING SYSTEM

The part numbering system for SynQor's PowerQor DC/DC converters follows the format shown in the example below.

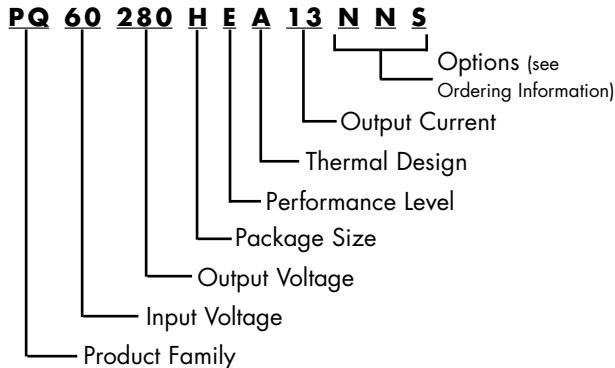

The first 12 characters comprise the base part number and the last 3 characters indicate available options. Although there are no default values for enable logic and pin length, the most common options are negative logic and 0.145" pins. These part numbers are more likely to be readily available in stock for evaluation and prototype quantities. A "-G" suffix indicates 6/6 RoHS compliance.

### Application Notes

A variety of application notes and technical white papers can be downloaded in pdf format from our [website](#).

### PATENTS (additional patent applications may be filed)

SynQor holds the following patents, one or more of which might apply to this product:

5,999,417	6,222,742	6,545,890	6,577,109
6,594,159	6,731,520	6,894,468	6,896,526
6,927,987	7,050,309	7,072,190	7,085,146

### Contact SynQor for further information:

**Phone:** 978-849-0600  
**Toll Free:** 888-567-9596  
**Fax:** 978-849-0602  
**E-mail:** [power@synqor.com](mailto:power@synqor.com)  
**Web:** [www.synqor.com](http://www.synqor.com)  
**Address:** 155 Swanson Road  
 Boxborough, MA 01719  
 USA

### ORDERING INFORMATION

The tables below show the valid model numbers and ordering options for converters in this product family. When ordering SynQor converters, please ensure that you use the complete 15 character part number consisting of the 12 character base part number and the additional 3 characters for options. To order 6/6 RoHS compliant product please add a "-G" suffix.

Model Number	Input Voltage	Output Voltage	Max Output Current
PQ60280HE w13xyz	35 - 75 V	28.0 V	12.8 A

The following option choices must be included in place of the x y z spaces in the model numbers listed above.

Options Description: w x y z			
Thermal Design	Enable Logic	Pin Length	Feature Set
A - Open Frame B - Threaded Baseplate F - Non-Threaded Baseplate	P - Positive N - Negative	K - 0.110" N - 0.145" R - 0.180" Y - 0.250"	S - Standard H - Higher Trim Range & OVP

#### Warranty

SynQor offers a three (3) year limited warranty. Complete warranty information is listed on our [website](#) or is available upon request from SynQor.

Information furnished by SynQor is believed to be accurate and reliable. However, no responsibility is assumed by SynQor for its use, nor for any infringements of patents or other rights of third parties which may result from its use. No license is granted by implication or otherwise under any patent or patent rights of SynQor.