

<b>35-75V</b> Input	<b>100V</b> Transient Input	<b>24V</b> Output	<b>600W</b> Max Power	<b>2250V dc</b> Isolation	<b>Half-brick</b> DC-DC Converter
------------------------	--------------------------------	----------------------	--------------------------	------------------------------	--------------------------------------

The PQ60240HZx25 PowerQor Zeta Half-brick converter is a next-generation, board-mountable, isolated, fixed switching frequency DC/DC converter. The Zeta series offers industry leading power density for standard isolated DC/DC converters with both a wide input range and a tightly regulated output. This module supplies an isolated step down voltage from 35-75V to 24V and is available in openframe and encased versions. RoHS Compliant (see last page).

## PowerQor®



PQ60240HZx25 Model

### Protection Features

- Input under-voltage lockout disables converter at low  $V_{in}$  conditions
- Output current limit and short circuit protection protects converter and load from permanent damage and consequent hazardous conditions
- Active back bias limit provides smooth startup with external load induced pre-bias
- Auto-recovery output over-voltage protection protects load from damaging voltages
- Thermal shutdown protects converter from abnormal environmental conditions

### Mechanical Features

- Industry standard half-brick pin-out configuration
- Size: 2.30" x 2.40" x 0.428", 58.4 x 61.0 x 10.9 mm
- Total weight: 2.6 oz. (75 g)

### Control Features

- On/Off control referenced to input side (positive and negative logic options are available)
- Remote sense for the output voltage

### Safety Features

- UL 60950-1:2007
- CAN/CSA-C22.2 No. 60950-1:2007
- EN60950-1:A12:2011
- IEC 61000-4-2

### Operational Features

- High efficiency, 94% at full rated load current
- Delivers up to 25A of output current (600W)
- Input voltage range: 35-75V
- Fixed frequency switching provides predictable EMI performance
- No minimum load requirement means no preload resistors required
- Wide output voltage trim range (-50%, +10%), see trim section
- Optional: Active current share for parallel applications

### Contents

	Page No.
Mechanical Information . . . . .	2
Electrical Characteristics . . . . .	4
Standards & Qualifications . . . . .	6
Technical Figures . . . . .	7
Applications Section . . . . .	10
Ordering Information . . . . .	15

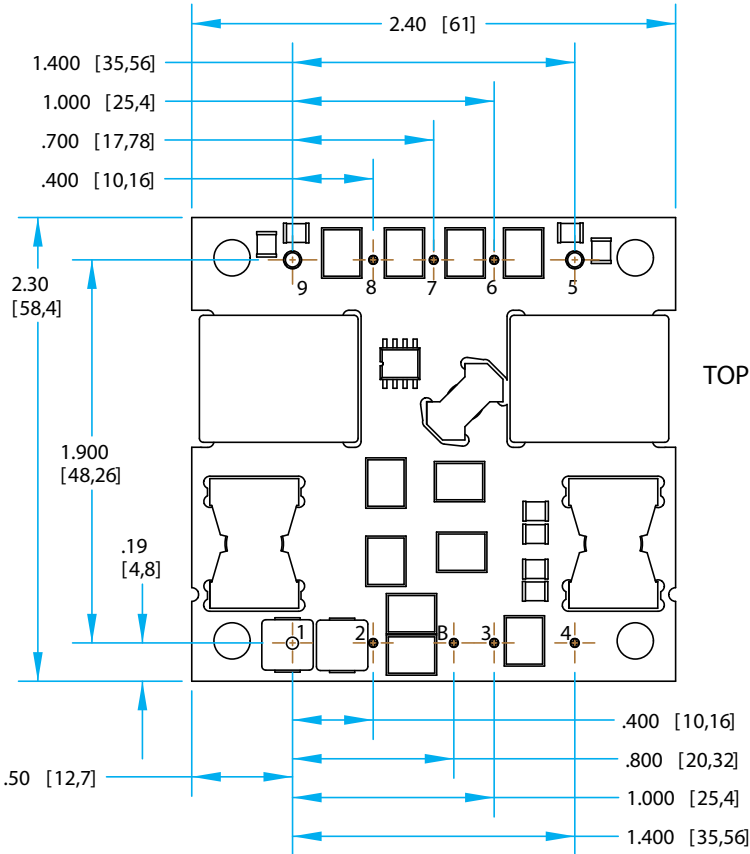

TOP VIEW

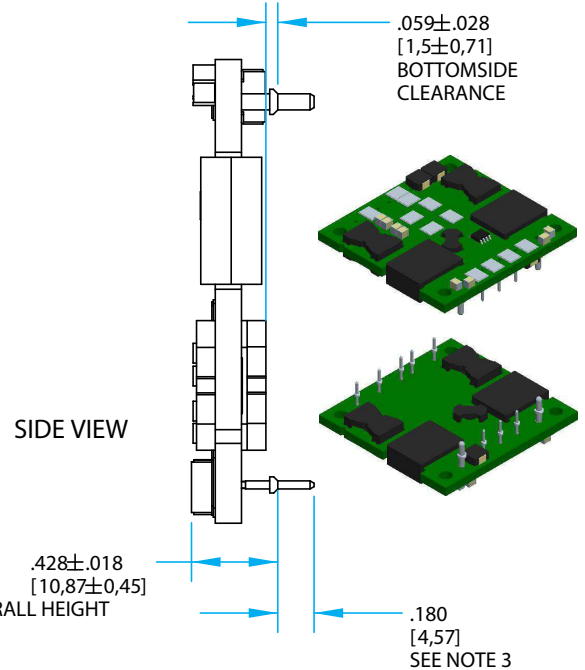

SIDE VIEW

### NOTES

- 1) Pins 1-4, 6-8, and B are 0.040" (1.02mm) diameter, with 0.080" (2.03mm) diameter standoff shoulders.
- 2) Pins 5 and 9 are 0.080" (2.03 mm) diameter with 0.125" (3.18mm) diameter standoff shoulders.
- 3) Other pin extension lengths available.
- 4) All Pins: Material - Copper Alloy  
Finish: Matte Tin over Nickel plate
- 5) Undimensioned components are shown for visual reference only.
- 6) All dimensions in inches (mm)  
Tolerances: x.xx +/-0.02 in. (x.x +/-0.5mm)  
x.xxx +/-0.010 in. (x.xx +/-0.25mm)
- 7) Open Frame Weight: 2.6 oz. (75 g)
- 8) Workmanship: Meets or exceeds IPC-A-610 Class II
- 9) UL/TUV standards require a clearance greater than 0.04" 1.02mm) between input and output for Basic insulation. This issue should be considered if any copper traces are on the top side of the user's board. Note that the ferrite cores are considered part of the input/primary circuit.

### PIN DESIGNATIONS

Pin	Name	Function
1	Vin(+)	Positive input voltage
2	ON/OFF	TTL input to turn converter on and off, referenced to Vin(-), with internal pull up.
B	SHARE(+)	Active current share differential pair (See note 4)
3	SHARE(-)	
4	Vin(-)	Negative input voltage
5	Vout(-)	Negative output voltage
6	SENSE(-)	Negative remote sense (See note 1)
7	TRIM	Output voltage trim (See note 2)
8	SENSE(+)	Positive remote sense (See note 3)
9	Vout(+)	Positive output voltage

Notes:

- 1) SENSE(-) should be connected to Vout(-) either remotely or at the converter.
- 2) Leave TRIM pin open for nominal output voltage.
- 3) SENSE(+) should be connected to Vout(+) either remotely or at the converter.
- 4) Full-Featured option only. Pin 3 and Pin B not populated on standard model.

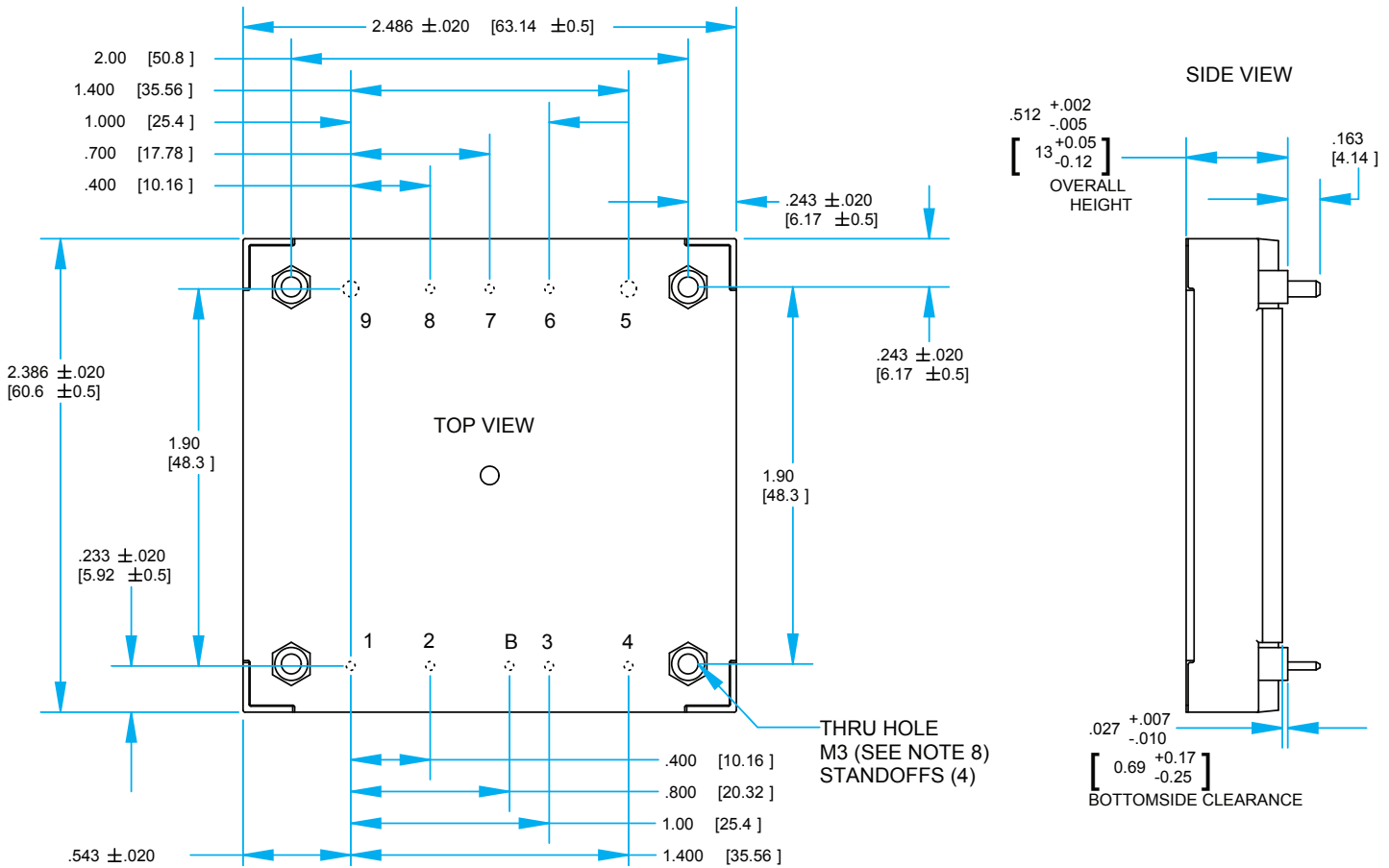

### NOTES

- Applied torque per screw should not exceed 6in-lb. (0.7 Nm).
- Baseplate flatness tolerance is 0.004" (.10 mm) TIR for surface.
- Pins 1-4, 6-8, and B are 0.040" (1.02mm) diameter, with 0.080" (2.03mm) diameter standoff shoulders.
- Pins 5 and 9 are 0.080" (2.03 mm) diameter with 0.125" (3.18 mm) diameter standoff shoulders.
- All Pins: Material - Copper Alloy; Finish - Matte Tin over Nickel plate  
Tolerances:  
x.xxx +/-0.02 in. (x.x +/-0.5mm)  
x.xxx +/-0.010 in. (x.xx +/-0.25mm)  
unless otherwise noted.
- Undimensioned components are shown for visual reference only.
- Weight: 5 oz. (142g) typical
- Threaded and Non-Threaded options available
- All dimensions in inches (mm).
- Recommended pin length is 0.03" (0.76 mm) greater than the PCB thickness.
- Workmanship: Meets or exceeds IPC-A-610C Class II

### PIN DESIGNATIONS

Pin	Name	Function
1	Vin(+)	Positive input voltage
2	ON/OFF	TTL input to turn converter on and off, referenced to Vin(-), with internal pull up.
B	SHARE(+)	Active current share differential pair (See note 4)
3	SHARE(-)	
4	Vin(-)	Negative input voltage
5	Vout(-)	Negative output voltage
6	SENSE(-)	Negative remote sense (See note 1)
7	TRIM	Output voltage trim (See note 2)
8	SENSE(+)	Positive remote sense (See note 3)
9	Vout(+)	Positive output voltage

#### Notes:

- SENSE(-) should be connected to Vout(-) either remotely or at the converter.
- Leave TRIM pin open for nominal output voltage.
- SENSE(+) should be connected to Vout(+) either remotely or at the converter.
- Full-Featured option only. Pin 3 and Pin B not populated on standard model.



# Technical Specifications

**Input: 35-75V**  
**Output: 24V**  
**Current: 25A**  
**Package: Half-brick**

## PQ60240HZx25 Electrical Characteristics

Ta = 25 °C, airflow rate = 300 LFM, Vin = 48V dc unless otherwise noted; full operating temperature range is -40 °C to +100 °C baseplate temperature with appropriate power derating. Specifications subject to change without notice.

Parameter	Min.	Typ.	Max.	Units	Notes & Conditions
<b>ABSOLUTE MAXIMUM RATINGS</b>					
Input Voltage					
Non-Operating	-1		100	V	Continuous
Operating			80	V	Continuous
Operating Transient Protection			100	V	1 s transient, square wave
Isolation Voltage					
Input to Output			2250	V	
Operating Temperature	-40		100	°C	
Storage Temperature	-55		125	°C	
Voltage at ON/OFF input pin	-2		18	V	
<b>INPUT CHARACTERISTICS</b>					
Operating Input Voltage Range	35	48	75	V	
Input Under-Voltage Lockout					
Turn-On Voltage Threshold	32.0	33.0	34.0	V	
Turn-Off Voltage Threshold	30.0	31.0	32.0	V	
Lockout Voltage Hysteresis	1.5	2.0	2.5	V	
Maximum Input Current			21	A	100% Load, 35V Vin, trimmed up 10%
No-Load Input Current		200	250	mA	
Disabled Input Current (Option N)		5	8	mA	
Disabled Input Current (Option P)	20	30	40	mA	
Response to Input Transient		4.5		V	0.50V/μs input transient, full load, 100μF load cap
Input Reflected Ripple Current		30		mA	RMS thru 4.7μH inductor
Input Terminal Ripple Current		150		mA	RMS
Recommended Input Fuse			40	A	Fast acting external fuse recommended
Recommended External Input Capacitance		220		μF	Typical ESR 0.1-0.2Ω; Figure 13
Input Filter Component Values (L\C)		0.75\11		μH\μF	Internal values
<b>OUTPUT CHARACTERISTICS</b>					
Output Voltage Set Point	23.60	24.00	24.34	V	
Output Voltage Regulation					
Over Line		±0.25		%	See note 1
Over Load		±0.25		%	See note 1
Over Temperature	-312		312	mV	
Total Output Voltage Range	23.28		24.72	V	Over sample, line, load, temperature & life
Output Voltage Ripple and Noise					20MHz bandwidth; see Note 2
Peak-to-Peak		280	560	mV	Full load
RMS		65	130	mV	Full load
Operating Output Current Range	0		25	A	Subject to thermal derating
Output DC Current-Limit Inception	27.5	30.0	32.5	A	Output Voltage 10% Low
Output DC Current-Limit Shutdown Voltage		9.6		V	See note 3
Back-Drive Current Limit while Enabled		8		A	Negative current drawn from output
Back-Drive Current Limit while Disabled	0	3	5	mA	Negative current drawn from output
Maximum Output Capacitance Electrolytic			6,000	μF	Nominal Vout at full load (resistive load)
<b>EFFICIENCY</b>					
100% Load		94		%	Figures 1 - 2
50% Load		95		%	Figures 1 - 2

## PQ60240HZx25 Electrical Characteristics (continued)

Ta = 25 °C, airflow rate = 300 LFM, Vin = 48V dc unless otherwise noted; full operating temperature range is -40 °C to +100 °C baseplate temperature with appropriate power derating. Specifications subject to change without notice.

Parameter	Min.	Typ.	Max.	Units	Notes & Conditions
<b>DYNAMIC CHARACTERISTICS</b>					
Output Voltage during Load Current Transient					
Step Change in Output Current (0.1A/μs)		800		mV	50% to 75% to 50% Iout max, 15 μF load cap
Step Change in Output Current (2A/μs)		1.5		V	50% to 75% to 50% Iout max, 15 μF load cap
Settling time		500		μs	To within 1% Vout nom
Turn-On Transient					
Turn-On Time	15	25	35	ms	Vout=90% nom, Figures 9 & 10; see note 5
Output Voltage Overshoot			2	%	
<b>ISOLATION CHARACTERISTICS</b>					
Isolation Voltage (dielectric strength)		2250		V	See Absolute Maximum Ratings
Isolation Resistance		30		MΩ	
Isolation Capacitance (input to output)		1000		pF	See Note 4
<b>TEMPERATURE LIMITS FOR POWER DERATING CURVES</b>					
Semiconductor Junction Temperature			125	°C	Package rated to 150°C
Board Temperature			125	°C	UL rated max operating temp 130°C
Transformer Temperature			125	°C	
<b>FEATURE CHARACTERISTICS</b>					
Switching Frequency Regulation Stage	230	240	250	kHz	
Switching Frequency Isolation Stage	115	120	125	kHz	
ON/OFF Control (Option P)					
Off-State Voltage	-2.0		0.8	V	
On-State Voltage	2.4		18.0	V	
ON/OFF Control (Option N)					
Off-State Voltage	2.4		18.0	V	
On-State Voltage	-2.0		0.8	V	
ON/OFF Control (Either Option)					Application notes; Figures A & B
Pull-Up Voltage		15	18	V	
Pull-Up Resistance		49.9		kΩ	
Output Voltage Trim Range	-50		10	%	Measured across Pins 8 & 6; Figure C
Output Over-Voltage Protection	118	123	128	%	Over Full Temperature Range; % of nominal Vout
Over-Temperature Shutdown		125		°C	Average PCB Temperature
Over-Temperature Shutdown Restart Hysteresis		10		°C	
<b>RELIABILITY CHARACTERISTICS</b>					
Calculated MTBF (Telcordia)		2.1		10 <sup>6</sup> Hrs.	TR-NWT-000332; 80% load, 300LFM, 40°C Ta
Calculated MTBF (MIL-217)		1.9		10 <sup>6</sup> Hrs.	MIL-HDBK-217F; 80% load, 300LFM, 40°C Ta
Field Demonstrated MTBF				10 <sup>6</sup> Hrs.	See our website for details

Note 1: Line and load regulation is limited by duty cycle quantization and does not indicate a shift in the internal voltage reference.

Note 2: For applications requiring reduced output voltage ripple and noise, consult SynQor applications support (e-mail: support@synqor.com)

Note 3: If the output voltage falls below the Output DC Current Limit Shutdown Voltage for more than 50ms, then the unit will enter into hiccup mode, with a 500ms off-time.

Note 4: Higher values of isolation capacitance can be added external to the module.

Note 5: Additional 25ms between enable and start of Turn-On time for N logic full-featured units to set up communication.



## Technical Specifications

**Input: 35-75V**  
**Output: 24V**  
**Current: 25A**  
**Package: Half-brick**

### Standards Compliance & Qualification Testing

Parameter	Notes & Conditions
<b>STANDARDS COMPLIANCE</b>	
UL 60950-1:2007	Basic insulation
CAN/CSA-C22.2 No. 60950-1:2007	
EN60950-1:A12:2011	
IEC 61000-4-2	ESD test, 8 kV - NP, 15 kV air - NP (Normal Performance)

Note: An external input fuse must always be used to meet these safety requirements. Contact SynQor for official safety certificates on new releases or download from the SynQor website.

Parameter	# Units	Test Conditions
<b>QUALIFICATION TESTING</b>		
Life Test	32	95% rated Vin and load, units at derating point, 1000 hours
Vibration	5	10-55 Hz sweep, 0.060" total excursion, 1 min./sweep, 120 sweeps for 3 axis
Mechanical Shock	5	100g minimum, 2 drops in x, y and z axis
Temperature Cycling	10	-40 °C to 100 °C, unit temp. ramp 15 °C/min., 500 cycles
Power/Thermal Cycling	5	Toperating = min to max, Vin = min to max, full load, 100 cycles
Design Marginality	5	Tmin-10 °C to Tmax+10 °C, 5 °C steps, Vin = min to max, 0-105% load
Humidity	5	85 °C, 85% RH, 1000 hours, continuous Vin applied except 5 min/day
Solderability	15 pins	MIL-STD-883, method 2003

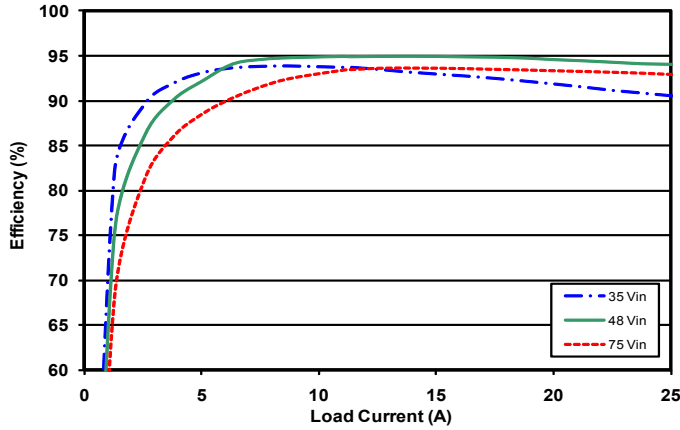

Figure 1: Efficiency at nominal output voltage vs. load current for minimum, nominal, and maximum input voltage at 25°C.

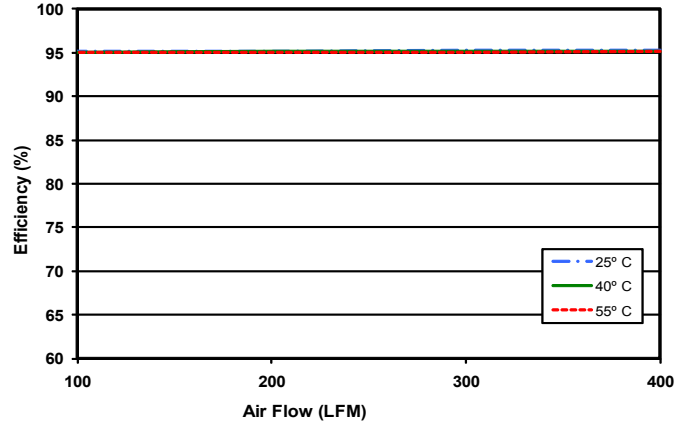

Figure 2: Efficiency at nominal output voltage and 60% rated power vs. airflow rate for ambient air temperatures of 25°C, 40°C, and 55°C (nominal input voltage).

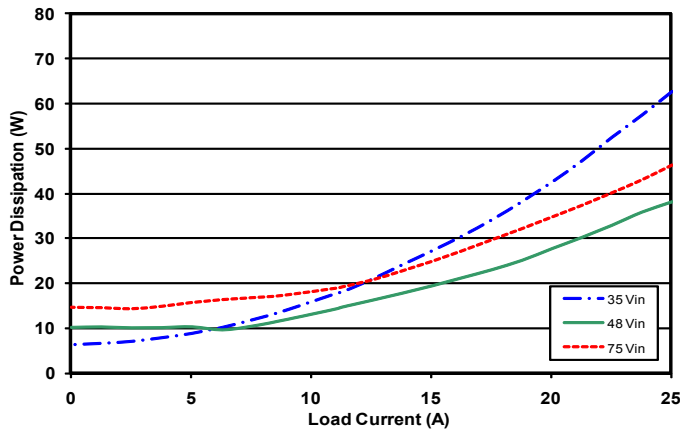

Figure 3: Power Dissipation at nominal output voltage vs. load current for minimum, nominal, and maximum input voltage at 25°C.

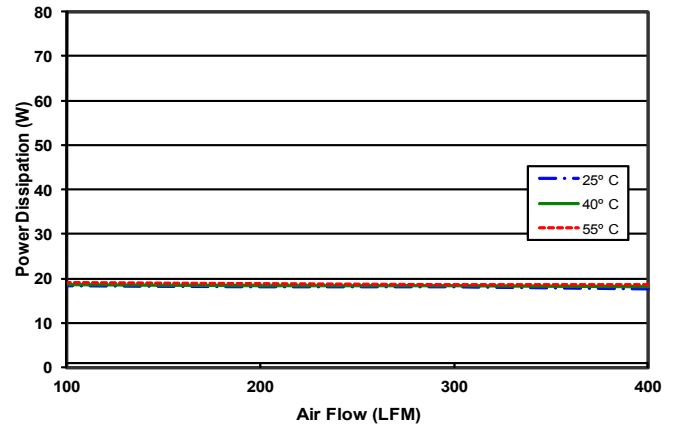

Figure 4: Power Dissipation at nominal output voltage and 60% rated power vs. airflow rate for ambient air temperatures of 25°C, 40°C, and 55°C (nominal input voltage).

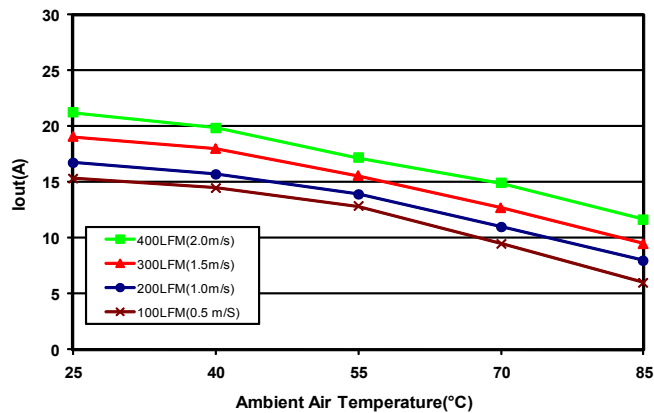

Figure 5: Thermal Derating (max output current vs. ambient air temperature) for airflow rates of 100 LFM through 400 LFM with air flowing from pin 4 to pin 1 (nominal input voltage).

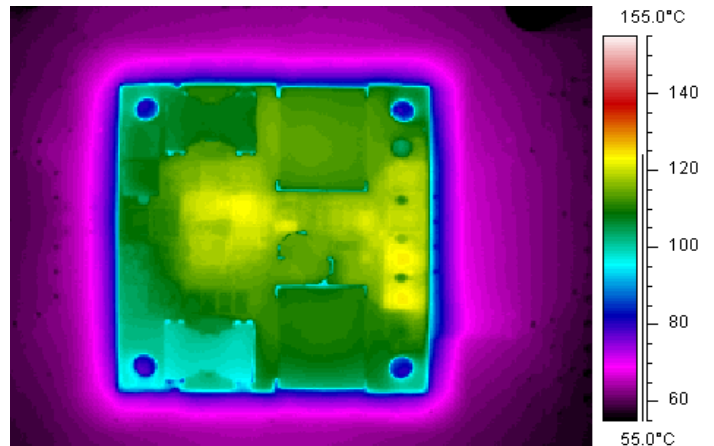
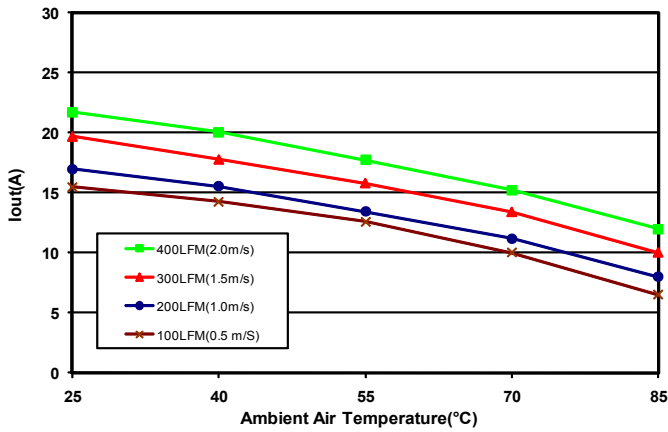
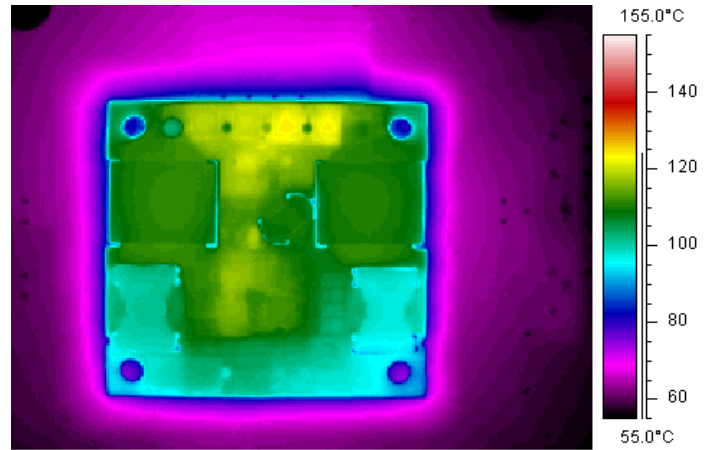

Figure 6: Thermal Image of converter at 13.9 amp load current (333.6W) with 55°C air flowing at the rate of 200 LFM. Air is flowing from pin 4 to pin 1 (nominal input voltage).



**Figure 7: Thermal Derating** (max output current vs. ambient air temperature) for airflow rates of 100 LFM through 400 LFM with air flowing lengthwise from input to output (nominal input voltage).



**Figure 8: Thermal Image** of converter at 13.5 amp load current (324W) with 55°C air flowing at the rate of 200 LFM. Air is flowing across the converter from input to output (nominal input voltage).

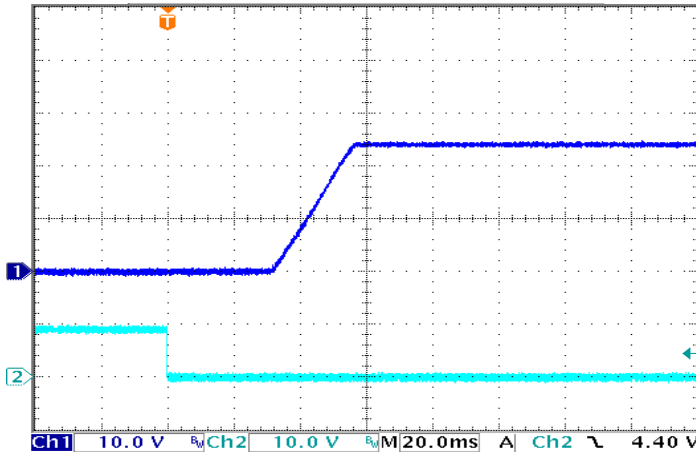

**Figure 9: Turn-on Transient** at full load (resistive load) (20 ms/div). Input voltage pre-applied. Top Trace: Vout (10V/div). Bottom Trace: ON/OFF input (10V/div)

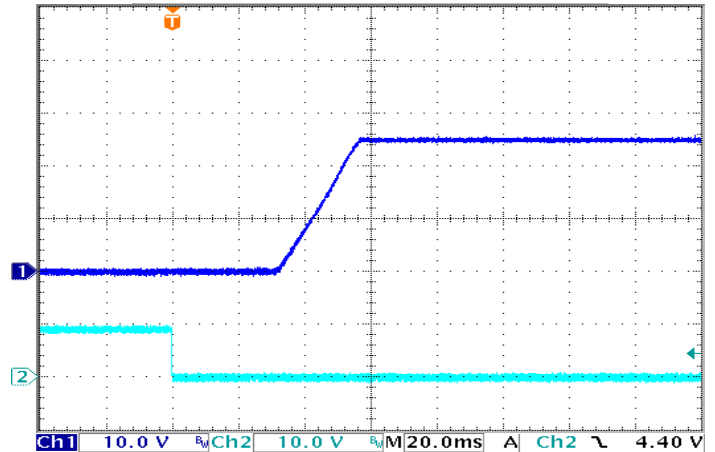

**Figure 10: Turn-on Transient** at zero load (20 ms/div). Top Trace: Vout (10V/div). Bottom Trace: ON/OFF input (10V/div)

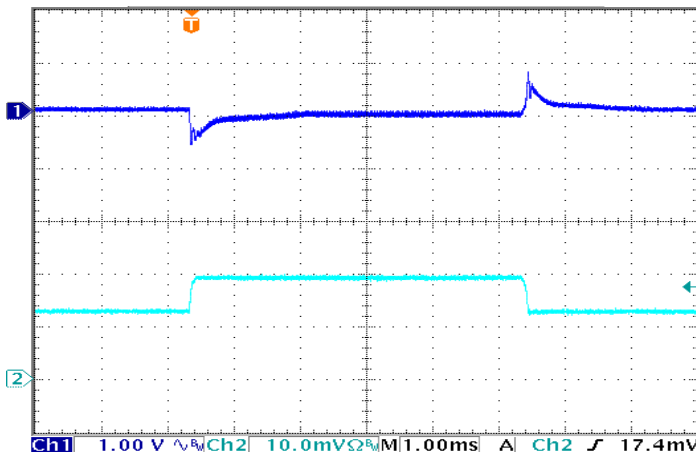

**Figure 11: Output Voltage Response to Step-Change in Load Current** (50%-75%-50% of Iout(max); dI/dt = 0.1A/μs). Load cap: 1μF ceramic and 15μF tantalum output capacitors. Top trace: Vout (1V/div). Bottom trace: Iout (10A/div).

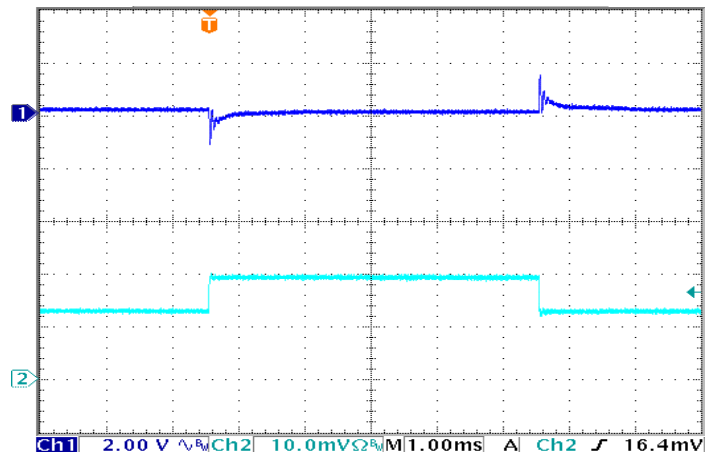

**Figure 12: Output Voltage Response to Step-Change in Load Current** (50%-75%-50% of Iout(max); dI/dt = 2A/μs). Load cap: 1μF ceramic and 15μF tantalum output capacitors. Top trace: Vout (2V/div). Bottom trace: Iout (10A/div).

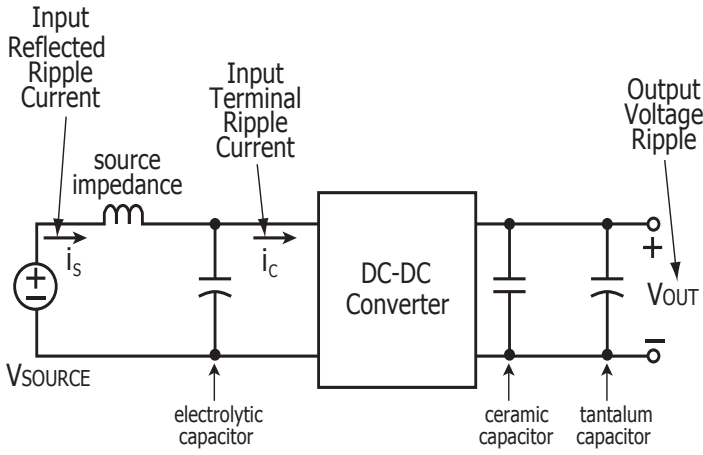

**Figure 13: Test Set-up Diagram** showing measurement points for Input Terminal Ripple Current (Figure 14), Input Reflected Ripple Current (Figure 15) and Output Voltage Ripple (Figure 16).

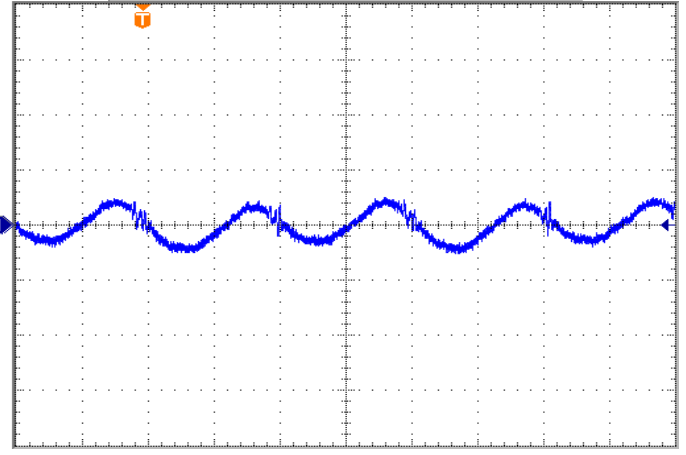

**Figure 14: Input Terminal Ripple Current,  $i_c$** , at full rated output current and nominal input voltage with  $4.7\mu H$  source impedance and  $220\mu F$  electrolytic capacitor (Ch.1 500mA/div,  $2\mu s$ /div). (See Figure 13).

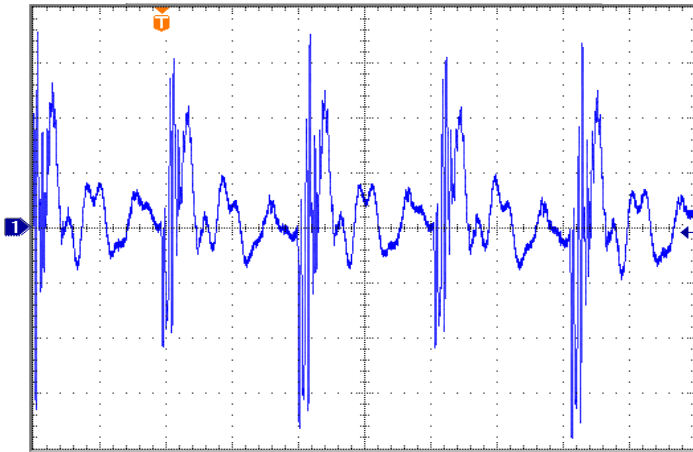

**Figure 15: Input Reflected Ripple Current,  $i_s$** , through a  $4.7\mu H$  source inductor at nominal input voltage and rated load current (10 mA/div,  $2\mu s$ /div). (See Figure 13).

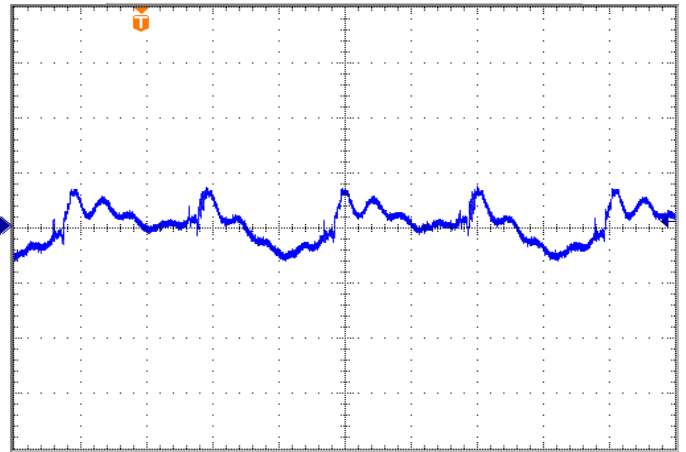

**Figure 16: Output Ripple voltage** at nominal input voltage and rated load current (200 mV/div,  $2\mu s$ /div). Load capacitance:  $1\mu F$  ceramic and  $15\mu F$  tantalum output capacitors. Bandwidth: 20 MHz. (See Figure 13).

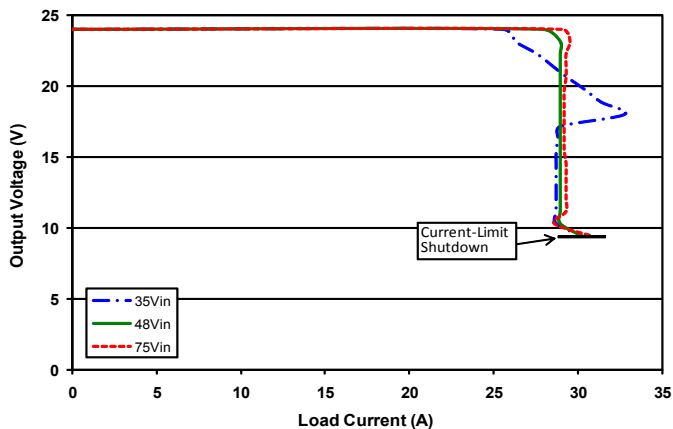

**Figure 17: Output I-V Characteristics** (output voltage vs. load current) showing typical current limit curves and converter shutdown points.

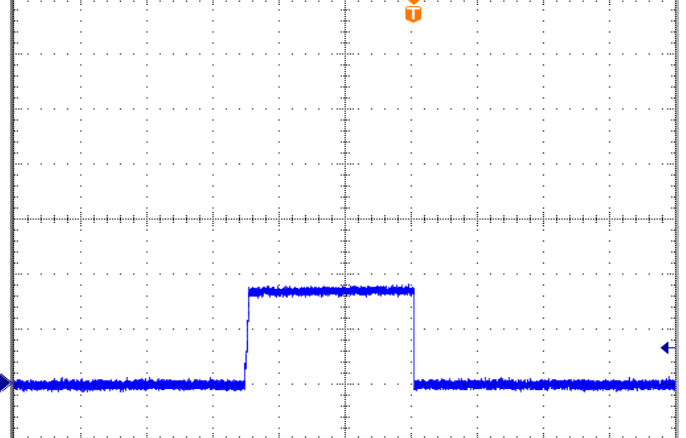

**Figure 18: Output Short Load Current** (20A/div) as a function of time when the converter attempts to turn on into a  $1 m\Omega$  short circuit (20ms/div).

### BASIC OPERATION AND FEATURES

This converter series uses a two-stage power conversion topology. The first stage keeps the output voltage constant over variations in line, load, and temperature. The second stage uses a transformer to provide the functions of input/output isolation and voltage step-down to achieve the low output voltage required.

Both the first stage and the second stage switch at a fixed frequency for predictable EMI performance. Rectification of the transformer's output is accomplished with synchronous rectifiers. These devices, which are MOSFETs with a very low on-state resistance, dissipate significantly less energy than Schottky diodes, enabling the converter to achieve high efficiency.

Dissipation throughout the converter is so low that it does not require a heatsink or even a baseplate for operation in many applications; however, adding a heatsink provides improved thermal derating performance in extreme situations. To further withstand harsh environments and thermally demanding applications, certain models are available totally encased. See Ordering Information page for available thermal design options.

SynQor half-brick converters use the industry standard footprint and pin-out.

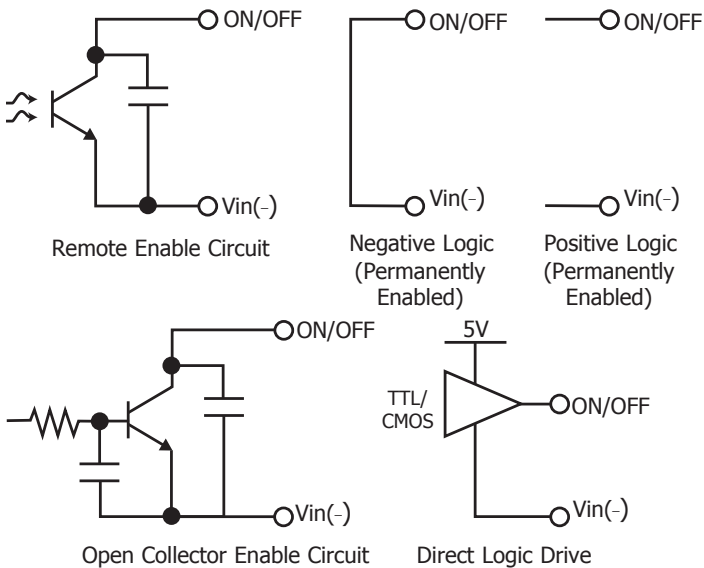

Figure A: Various circuits for driving the ON/OFF pin.

### CONTROL FEATURES

**REMOTE ON/OFF (Pin 2):** The ON/OFF input, Pin 2, permits the user to control when the converter is on or off. This input is referenced to the return terminal of the input bus, Vin(-).

In the negative logic version, the ON/OFF signal is active low (meaning that a low voltage turns the converter on). In the positive logic version, the ON/OFF input is active high (meaning that a high voltage turns the converter on). Figure A details possible circuits for driving the ON/OFF pin. Figure B is a detailed look of the internal ON/OFF circuitry.

**REMOTE SENSE Pins 8(+) and 6(-):** The SENSE(+) and SENSE(-) inputs correct for voltage drops along the conductors that connect the converter's output pins to the load.

Pin 8 should be connected to Vout(+) and Pin 6 should be connected to Vout(-) at the point on the board where regulation is desired. If these connections are not made, the converter will deliver an output voltage that is slightly higher than its specified value.

**Note:** The Output Over-Voltage Protection circuit senses the voltage across the output (Pins 9 and 5) to determine when it should trigger, not the voltage across the converter's sense leads (Pins 8 and 6). Therefore, the resistive drop on the board should be small enough so that output OVP does not trigger, even during load transients.

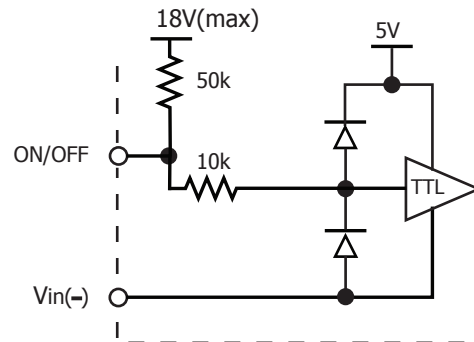

Figure B: Internal ON/OFF pin circuitry

**OUTPUT VOLTAGE TRIM (Pin 7):** The TRIM input permits the user to adjust the output voltage across the sense leads up or down according to the trim range specifications. SynQor uses industry standard trim equations.

To decrease the output voltage, the user should connect a resistor between Pin 7 (TRIM) and Pin 6 (SENSE(-) input). For a desired decrease of the nominal output voltage, the value of the resistor should be:

$$R_{\text{trim-down}} = \left( \frac{100\%}{\Delta\%} - 2 \right) \text{ k}\Omega$$

where

$$\Delta\% = \left| \frac{V_{\text{nominal}} - V_{\text{desired}}}{V_{\text{nominal}}} \right| \times 100\%$$

To increase the output voltage, the user should connect a resistor between Pin 7 (TRIM) and Pin 8 (SENSE(+) input). For a desired increase of the nominal output voltage, the value of the resistor should be:

$$R_{\text{trim-up}} = \frac{\left( \frac{V_{\text{nominal}}}{1.225} - 2 \right) \times V_{\text{desired}} + V_{\text{nominal}}}{V_{\text{desired}} - V_{\text{nominal}}} \text{ k}\Omega$$

The Trim Graph in Figure C shows the relationship between the trim resistor value and R<sub>trim-up</sub> and R<sub>trim-down</sub>, showing the total range the output voltage can be trimmed up or down.

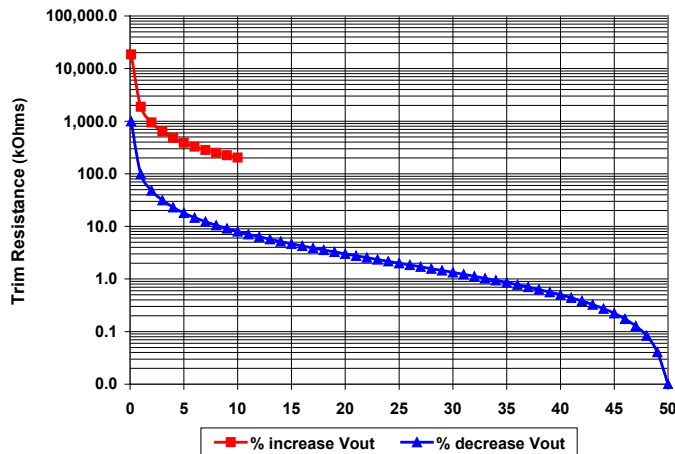

Figure C: Trim Graph

**Note:** The TRIM feature does not affect the voltage at which the output over-voltage protection circuit is triggered. Trimming the output voltage too high may cause the over-voltage protection circuit to engage, particularly during transients.

It is not necessary for the user to add capacitance at the TRIM pin. The node is internally filtered to eliminate noise.

**Total DC Variation of Vout:** For the converter to meet its full specifications, the maximum variation of the DC value of V<sub>out</sub>, due to both trimming and remote load voltage drops, should not be greater than that specified for the output voltage trim range.

## Protection Features

**Input Under-Voltage Lockout:** The converter is designed to turn off when the input voltage is too low, helping to avoid an input system instability problem, which is described in more detail in the application note titled "Input System Instability" on the SynQor website. The lockout circuitry is a comparator with DC hysteresis. When the input voltage is rising, it must exceed the typical "Turn-On Voltage Threshold" value\* before the converter will turn on. Once the converter is on, the input voltage must fall below the typical Turn-Off Voltage Threshold value before the converter will turn off.

**Output Current Limit:** If the output current exceeds the "Output DC Current Limit Inception" point\*, then a fast linear current limit controller will reduce the output voltage to maintain a constant output current. If as a result, the output voltage falls below the "Output DC Current Limit Shutdown Voltage"\* for more than 50ms, then the unit will enter into hiccup mode, with a 500ms off-time. The unit will then automatically attempt to restart.

**Back-Drive Current Limit:** If there is negative output current of a magnitude larger than the "Back-Drive Current Limit while Enabled" specification\*, then a fast back-drive limit controller will increase the output voltage to maintain a constant output current. If this results in the output voltage exceeding the "Output Over-Voltage Protection" threshold\*, then the unit will shut down.

**Output Over-Voltage Limit:** If the voltage across the output pins exceeds the Output Over-Voltage Protection threshold, the converter will immediately stop switching. This prevents damage to the load circuit due to 1) excessive series resistance in output current path from converter output pins to sense point, 2) a release of a short-circuit condition, or 3) a release of a current limit condition. Load capacitance determines exactly how high the output voltage will rise in response to these conditions. After 500ms the converter will automatically restart for all but the S Feature Set option, which is latching and will not restart until input power is cycled or the ON/OFF input is toggled.

**Over-Temperature Shutdown:** A temperature sensor on the converter senses the average temperature of the module. The thermal shutdown circuit is designed to turn the converter off when the temperature at the sensed location reaches the "Over-Temperature Shutdown" value\*. It will allow the converter to turn on again when the temperature of the sensed location falls by the amount of the "Over-Temperature Shutdown Restart Hysteresis" value\*.

**Startup Inhibit Period:** The Startup Inhibit Period ensures that the converter will remain off for approximately 500ms when it is shut down due to a fault. This generates a 2 Hz "hiccup mode," which prevents the converter from overheating. In all, there are three ways that the converter can be shut down, initiating a Startup Inhibit Period:

- Output Over-Voltage Protection
- Current Limit
- Short Circuit Protection

\* See Electrical Characteristics section.

### APPLICATION CONSIDERATIONS

**Input System Instability:** This condition can occur because any DC-DC converter appears incrementally as a negative resistance load. A detailed application note titled "Input System Instability" is available on the SynQor website which provides an understanding of why this instability arises, and shows the preferred solution for correcting it.

**Application Circuits:** A typical circuit diagram, Figure D below details the input filtering and voltage trimming.

**Input Filtering and External Input Capacitance:** Figure E below shows the internal input filter components. This filter dramatically reduces input terminal ripple current, which otherwise could exceed the rating of an external electrolytic input capacitor. The recommended external input capacitance is specified in the Input Characteristics section of the Electrical Specifications. More detailed information is available in the application note titled "EMI Characteristics" on the SynQor website.

**Output Filtering and External Output Capacitance:** The internal output filter components are shown in Figure E below. This filter dramatically reduces output voltage ripple. Some minimum external output capacitance is required, as specified in the Output Characteristics area of the Electrical Characteristics section. No damage will occur without this capacitor connected, but peak output voltage ripple will be much higher.

**Thermal Considerations:** For baseplated and encased versions, the max operating baseplate temperature,  $T_B$ , is 100°C. Refer to the Thermal Derating Curves in the Technical Figures section to see the available output current at baseplate temperatures below 100°C.

A power derating curve can be calculated for any heatsink that is attached to the base-plate of the converter. It is only necessary to determine the thermal resistance,  $R_{THBA}$ , of the chosen heatsink between the baseplate and the ambient air for a given airflow rate. This information is usually available from the heatsink vendor. The following formula can be used to determine the maximum power the converter can dissipate for a given thermal condition if its base-plate is to be no higher than 100°C.

$$P_{diss}^{max} = \frac{100^{\circ}C - T_A}{R_{THBA}}$$

This value of maximum power dissipation can then be used in conjunction with the data shown in the Power Dissipation Curves in the Technical Figures section to determine the maximum load current (and power) that the converter can deliver in the given thermal condition.

For convenience, Thermal Derating Curves are provided in the Technical Figures section.

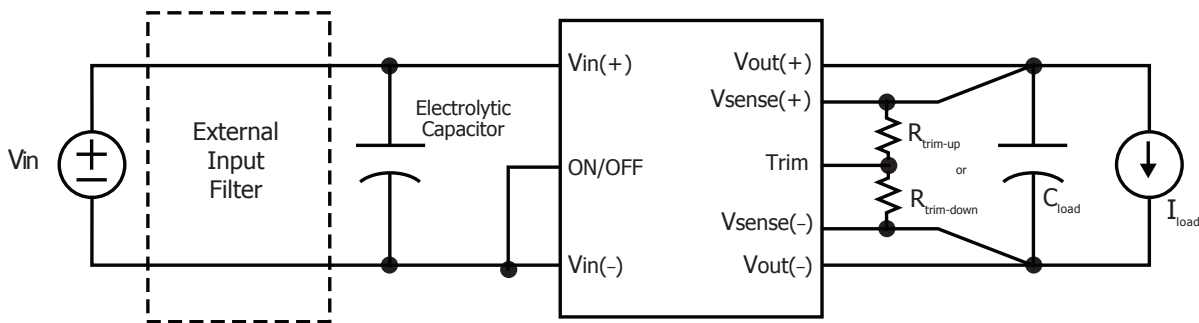

Figure D: Typical application circuit(negative logic unit, permanently enabled)

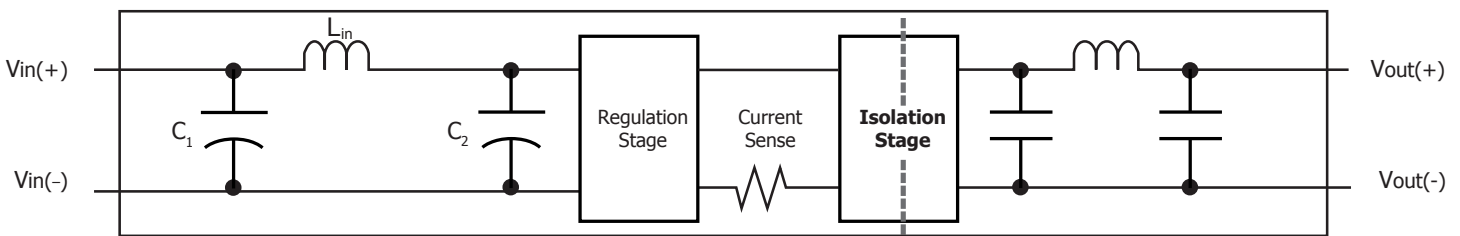

Figure E: Internal Input and Output Filter Diagram (component values listed in Electrical Characteristics section).

### Full-Featured Application Notes

The full-featured option, which is specified by an "F" as the last character of the part number, supports current sharing by adding two additional pins: SHARE(+) and SHARE(-)

**Connection of Paralleled Units:** Up to 100 units can be placed in parallel. In this current share architecture, one unit is dynamically chosen to act as a master, controlling all other units. It cannot be predicted which unit will become the master at any given time, so units should be wired symmetrically (see Fig E).

- Input power pins and output power pins should be tied together between units, preferably with wide overlapping copper planes.
- The SHARE(+) and SHARE(-) pins should be routed between all paralleled units as a differential pair.
- The ON/OFF pins should be connected in parallel, and rise/fall times should be kept below 2ms.
- The SENSE(+) and SENSE(-) pins should be connected either locally at each unit or separately to a common sense point.
- If the TRIM pin is used, then each unit should have its own trim resistor connected locally between TRIM and SENSE(+) or SENSE(-).

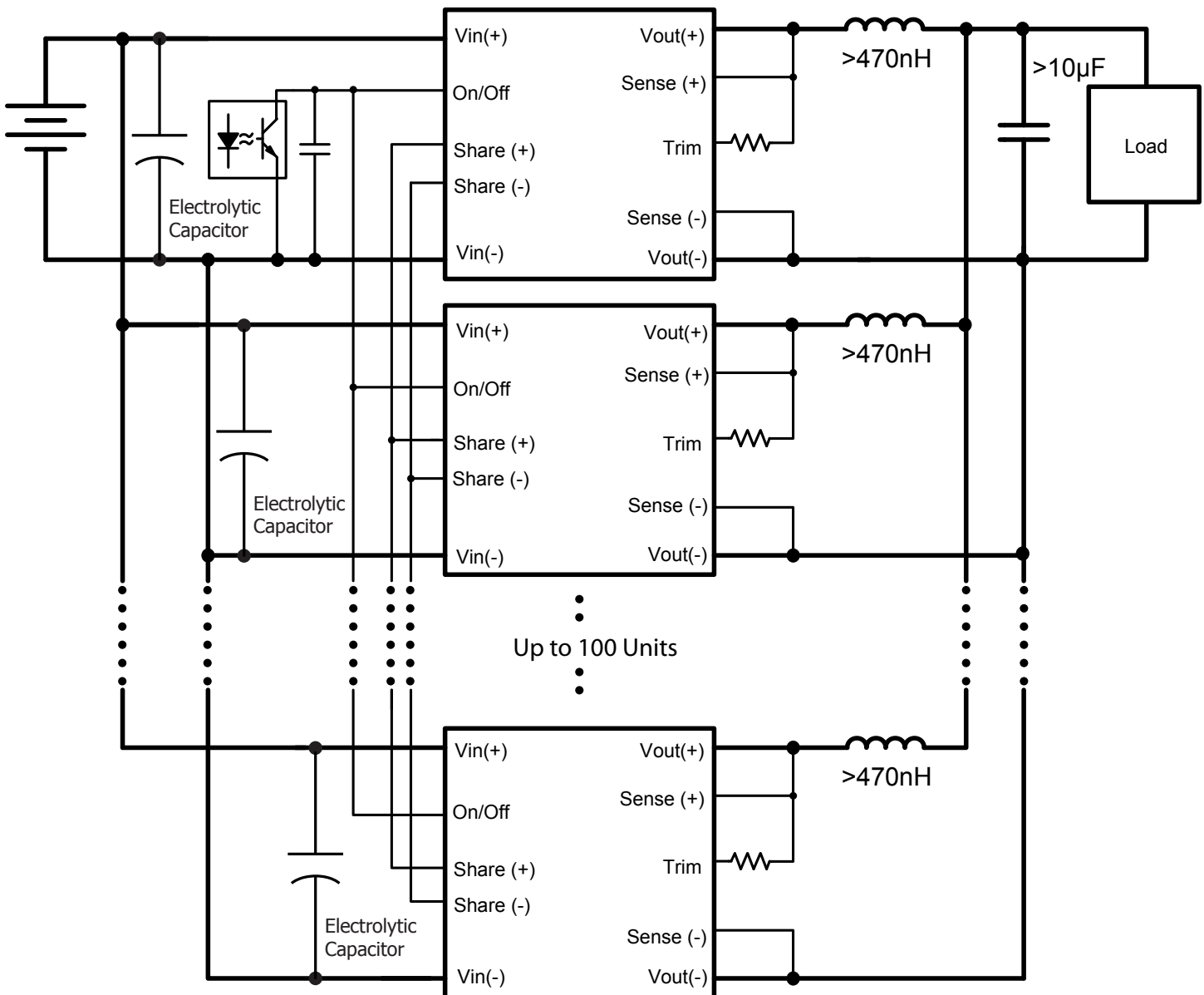

Figure H: Typical application circuit for paralleling of full-featured units

**Automatic Configuration:** The micro-controller inside each power converter unit is programmed at the factory with a unique chip number. In every other respect, each shared unit is identical and has the same orderable part number.

On initial startup (or after the master is disabled or shuts down), each unit determines the chip number of every other unit currently connected to the shared serial bus formed by the SHARE(+) and SHARE(-) pins. The unit with the highest chip number dynamically reconfigures itself from slave to master. The rest of the units (that do not have the highest chip number) become slaves.

The master unit then broadcasts its control state over the shared serial bus on a cycle-by-cycle basis. The slave units interpret and implement the control commands sent by the master, mirroring every action of the master unit.

If the master is disabled or encounters a fault condition, all units will immediately shut down, and if the master unit is unable to restart, then the unit with the next highest chip number will become master. If a slave unit is disabled or encounters a fault condition, all other units continue to run, and the slave unit can restart seamlessly.

**Automatic Interleaving:** The slave units automatically lock frequency with the master, and interleave the phase of their switching transitions for improved EMI performance. To obtain the phase angle relative to the master, each slave divides 360 degrees by the total number of connected units, and multiplies the result by its rank among chip numbers of connected units.

**ORing Diodes** placed in series with the converter outputs must also have a resistor smaller than 500  $\Omega$  placed in parallel. This resistor keeps the output voltage of a temporarily disabled slave unit consistent with the active master unit. If the output voltage of the slave unit were allowed to totally discharge, and the slave unit tried to restart, it would fail because the slave reproduces the duty cycle of the master unit, which is running in steady state and cannot repeat an output voltage soft-start.

**Common Mode Filtering** must be either a single primary side choke handling the inputs from all the paralleled units, or multiple chokes placed on the secondary side. This ensures that a solid Vin(-) plane is maintained between units.

**Resonance between Output Capacitors is Possible:** When multiple units are paralleled, it is possible to excite a series resonance between the output capacitors on two units and the air core inductors formed by the output pins. This is especially likely at higher output voltages where the on-board capacitance is relatively small. The problem is independent of external output capacitance. To ensure that this resonant frequency is below the switching frequency, for output voltages above 18V, it is recommended to add at least 470nH of inductance in series with each converter output. This could comprise the leakage inductance of a secondary side common mode choke.

**RS-485 Physical Layer:** The internal RS-485 transceiver includes many advanced protection features for enhanced reliability:

- Current Limiting and Thermal Shutdown for Driver Overload Protection
- IEC61000 ESD Protection to +/- 16.5kV
- Hot Plug Circuitry – SHARE(+) and SHARE(-)  
Outputs Remain Tri-State During Power-up/Power-down

**Internal Schottky Diode Termination:** Despite signaling at high speed with fast edges, external termination resistors are not necessary. Each receiver has four Schottky diodes built in, two for each line in the differential pair. These diodes clamp any ringing caused by transmission line reflections, preventing the voltage from going above about 5.5 V or below about -0.5 V. Any subsequent ringing then inherently takes place between 4.5 and 5.5 V or between -0.5 and 0.5 V. Since each receiver on the bus contains a set of clamping diodes to clamp any possible transmission line reflection, the bus does not necessarily need to be routed as a daisy-chain.

Pins SHARE(+) and SHARE(-) are referenced to Vin(-), and therefore should be routed as a differential pair near the Vin(-) plane for optimal signal integrity. The maximum difference in voltage between Vin(-) pins of all units on the share-bus should be kept within 0.3V to prevent steady-state conduction of the termination diodes. Therefore, the Vin(-) connections to each unit must be common, preferably connected by a single copper plane.

**Share Accuracy:** Inside each converter micro-controller, the duty cycle is generated digitally, making for excellent duty cycle matching between connected units. Some small duty cycle mismatch is caused by (well controlled) process variations in the MOSFET gate drivers. However, the voltage difference induced by this duty cycle mismatch appears across the impedance of the entire power converter, from input to output, multiplied by two, since the differential current flows out of one converter and into another. So, a small duty cycle mismatch yields very small differential currents, which remain small even when 100 units are placed in parallel.

In other current-sharing schemes, it is common to have a current-sharing control loop in each unit. However, due to the limited bandwidth of this loop, units do not necessarily share current on startup or during transients before this loop has a chance to respond. In contrast, the current-sharing scheme used in this product has no control dynamics: control signals are transmitted fast enough that the slave units can mirror the control state of the master unit on a cycle-by-cycle basis, and the current simply shares properly, from the first switching cycle to the last.

### Part Numbering System

The part numbering system for SynQor's dc-dc converters follows the format shown in the example below.

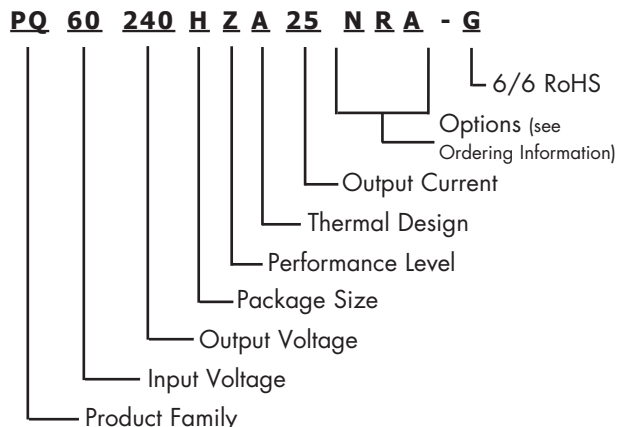

The first 12 characters comprise the base part number and the last 3 characters indicate available options. The "-G" suffix indicates 6/6 RoHS compliance.

### Application Notes

A variety of application notes and technical white papers can be downloaded in pdf format from our [website](#).

**RoHS Compliance:** The EU led RoHS (Restriction of Hazardous Substances) Directive bans the use of Lead, Cadmium, Hexavalent Chromium, Mercury, Polybrominated Biphenyls (PBB), and Polybrominated Diphenyl Ether (PBDE) in Electrical and Electronic Equipment. This SynQor product is 6/6 RoHS compliant. For more information please refer to SynQor's RoHS addendum available at our [RoHS Compliance / Lead Free Initiative web page](#) or e-mail us at [rohs@synqor.com](mailto:rohs@synqor.com).

### Ordering Information

The tables below show the valid model numbers and ordering options for converters in this product family. When ordering SynQor converters, please ensure that you use the complete 15 character part number consisting of the 12 character base part number and the additional characters for options. Add "-G" to the model number for 6/6 RoHS compliance.

Model Number	Input Voltage	Output Voltage	Max Output Current
PQ60240HZw25xyz-G	35-75V	24V	25A

The following options must be included in place of the **wxyz** spaces in the model numbers listed above.

Options Description: w x y z			
Thermal Design	Enable Logic	Pin Style	Feature Set
A - Open Frame C - Encased D - Encased with Non-Threaded Baseplate	N - Negative P - Positive	K - 0.110" N - 0.145" R - 0.180" Y - 0.250"	A - Standard F - Full Featured

Not all combinations make valid part numbers, please contact SynQor for availability. See the [Product Summary web page](#) for more options.

### PATENTS

SynQor holds the following U.S. patents, one or more of which apply to each product listed in this document. Additional patent applications may be pending or filed in the future.

5,999,417	6,222,742	6,545,890	6,577,109	6,594,159	6,731,520
6,894,468	6,896,526	6,927,987	7,050,309	7,072,190	7,085,146
7,119,524	7,269,034	7,272,021	7,272,023	7,558,083	7,564,702
7,765,687	7,787,261	8,023,290	8,149,597		

### Warranty

SynQor offers a three (3) year limited warranty. Complete warranty information is listed on our website or is available upon request from SynQor.

Information furnished by SynQor is believed to be accurate and reliable. However, no responsibility is assumed by SynQor for its use, nor for any infringements of patents or other rights of third parties which may result from its use. No license is granted by implication or otherwise under any patent or patent rights of SynQor.

### Contact SynQor for further information:

**Phone:** 978-849-0600  
**Toll Free:** 888-567-9596  
**Fax:** 978-849-0602  
**E-mail:** [power@synqor.com](mailto:power@synqor.com)  
**Web:** [www.synqor.com](http://www.synqor.com)  
**Address:** 155 Swanson Road  
 Boxborough, MA 01719  
 USA