

TimerBlox: Voltage Controlled Silicon Oscillator

FEATURES

- **Fixed-Frequency or Voltage-Controlled Operation**
 - **Fixed: Single Resistor Programs Frequency with <1.5% Max Error**
 - **VCO: Two Resistors Set VCO Center Frequency and Tuning Range**
- **Frequency Range: 488Hz to 2MHz**
- 2.25V to 5.5V Single Supply Operation
- 72µA Supply Current at 100kHz
- 500µs Start-Up Time
- VCO Bandwidth >300kHz at 1MHz
- CMOS Logic Output Sources/Sinks 20mA
- 50% Duty Cycle Square Wave Output
- Output Enable (Selectable Low or Hi-Z When Disabled)
- –55°C to 125°C Operating Temperature Range
- Available in Low Profile (1mm) SOT-23 (ThinSOT™) and 2mm × 3mm DFN Package

APPLICATIONS

- Low Cost Precision Programmable Oscillator
- Voltage-Controlled Oscillator
- High Vibration, High Acceleration Environments
- Replacement for Fixed Crystal and Ceramic Oscillators
- Portable and Battery-Powered Equipment

LT, LT, LTC and LTM, Linear Technology, TimerBlox and the Linear logo are registered trademarks and ThinSOT is a trademark of Linear Technology Corporation. All other trademarks are the property of their respective owners. Protected by U.S. Patents, including 6342817, 6614313.

DESCRIPTION

The LTC®6990 is a precision silicon oscillator with a programmable frequency range of 488Hz to 2MHz. It can be used as a fixed-frequency or voltage-controlled oscillator (VCO). The LTC6990 is part of the TimerBlox® family of versatile silicon timing devices.

A single resistor, R_{SET} , programs the LTC6990's internal master oscillator frequency. The output frequency is determined by this master oscillator and an internal frequency divider, N_{DIV} , programmable to eight settings from 1 to 128.

$$f_{OUT} = \frac{1\text{MHz}}{N_{DIV}} \cdot \frac{50\text{k}\Omega}{R_{SET}}, N_{DIV} = 1, 2, 4 \dots 128$$

Optionally, a second resistor at the SET input provides linear voltage control of the output frequency and can be used for frequency modulation. A narrow or wide VCO tuning range can be configured by the appropriate selection of the two resistors.

The LTC6990 includes an enable function that is synchronized with the master oscillator to ensure clean, glitch-free output pulses. The disabled output can be configured to be high impedance or forced low.

For easy configuration of the LTC6990, download the TimerBlox Designer tool at www.linear.com/timerblox.

TYPICAL APPLICATION

Voltage Controlled Oscillator with 16:1 Frequency Range

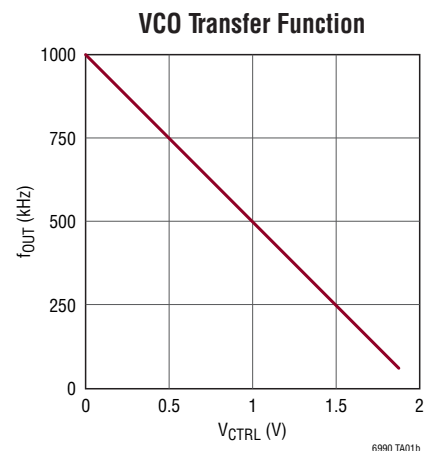
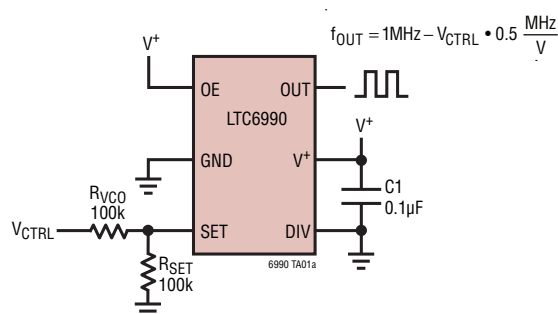

LTC6990

ABSOLUTE MAXIMUM RATINGS (Note 1)

Supply Voltage (V^+) to GND	6V	Specified Temperature Range (Note 3)	
Maximum Voltage on Any Pin		LTC6990C	0°C to 70°C
..... ($GND - 0.3V \leq V_{PIN} \leq (V^+ + 0.3V)$)		LTC6990I	-40°C to 85°C
Operating Temperature Range (Note 2)		LTC6990H	-40°C to 125°C
LTC6990C	-40°C to 85°C	LTC6990MP	-55°C to 125°C
LTC6990I	-40°C to 85°C	Junction Temperature	150°C
LTC6990H	-40°C to 125°C	Storage Temperature Range	-65°C to 150°C
LTC6990MP	-55°C to 125°C	Lead Temperature (Soldering, 10sec).....	300°C

PIN CONFIGURATION

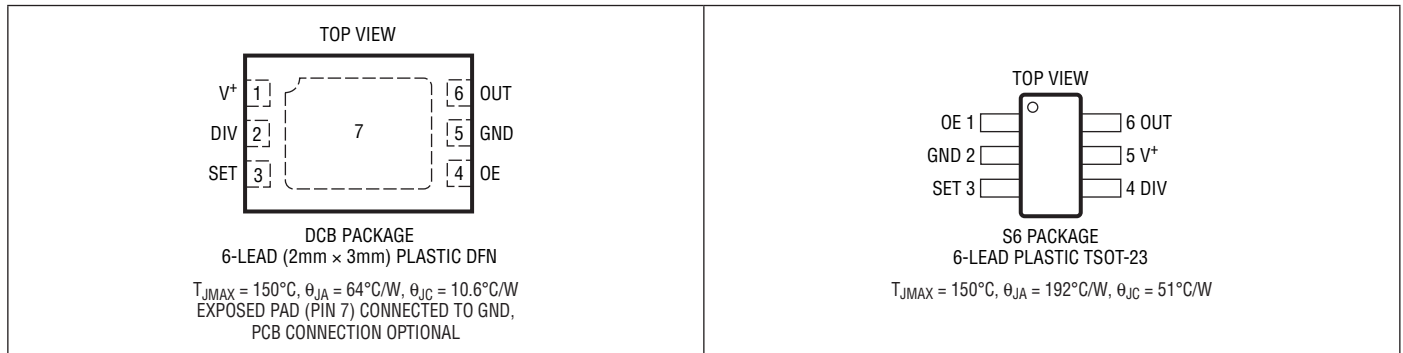

ORDER INFORMATION

Lead Free Finish

TAPE AND REEL (MINI)	TAPE AND REEL	PART MARKING*	PACKAGE DESCRIPTION	SPECIFIED TEMPERATURE RANGE
LTC6990DCB#TRMPBF	LTC6990DCB#TRPBF	LDWX	6-Lead (2mm × 3mm) Plastic DFN	0°C to 70°C
LTC6990IDCB#TRMPBF	LTC6990IDCB#TRPBF	LDWX	6-Lead (2mm × 3mm) Plastic DFN	-40°C to 85°C
LTC6990HDCB#TRMPBF	LTC6990HDCB#TRPBF	LDWX	6-Lead (2mm × 3mm) Plastic DFN	-40°C to 125°C
LTC6990CS6#TRMPBF	LTC6990CS6#TRPBF	LTDWW	6-Lead Plastic TSOT-23	0°C to 70°C
LTC6990IS6#TRMPBF	LTC6990IS6#TRPBF	LTDWW	6-Lead Plastic TSOT-23	-40°C to 85°C
LTC6990HS6#TRMPBF	LTC6990HS6#TRPBF	LTDWW	6-Lead Plastic TSOT-23	-40°C to 125°C
LTC6990MPS6#TRMPBF	LTC6990MPS6#TRPBF	LTDWW	6-Lead Plastic TSOT-23	-55°C to 125°C

TRM = 500 pieces. *Temperature grades are identified by a label on the shipping container.

Consult LTC Marketing for parts specified with wider operating temperature ranges.

Consult LTC Marketing for information on lead based finish parts.

For more information on lead free part marking, go to: <http://www.linear.com/leadfree/>

For more information on tape and reel specifications, go to: <http://www.linear.com/tapeandreel/>

ELECTRICAL CHARACTERISTICS The ● denotes the specifications which apply over the full operating temperature range, otherwise specifications are at $T_A = 25^\circ\text{C}$. Test conditions are $V^+ = 2.25\text{V}$ to 5.5V , $\text{OE} = V^+$, $\text{DIVCODE} = 0$ to 15 ($N_{\text{DIV}} = 1$ to 128), $R_{\text{SET}} = 50\text{k}$ to 800k , $R_{\text{LOAD}} = 5\text{k}$, $C_{\text{LOAD}} = 5\text{pF}$ unless otherwise noted.

SYMBOL	PARAMETER	CONDITIONS	MIN	TYP	MAX	UNITS	
f_{OUT}	Output Frequency	Recommended Range: $R_{\text{SET}} = 50\text{k}$ to 800k Extended Range: $R_{\text{SET}} = 25\text{k}$ to 800k	0.488 0.488		1000 2000	kHz kHz	
Δf_{OUT}	Frequency Accuracy (Note 4)	Recommended Range $R_{\text{SET}} = 50\text{k}$ to 800k	●	± 0.8	± 1.5 ± 2.2	% %	
		Extended Range $R_{\text{SET}} = 25\text{k}$ to 800k	●		± 2.4 ± 3.2	% %	
$\Delta f_{\text{OUT}}/\Delta T$	Frequency Drift Over Temperature		●	± 0.005		%/ $^\circ\text{C}$	
$\Delta f_{\text{OUT}}/\Delta V^+$	Frequency Drift Over Supply	$V^+ = 4.5\text{V}$ to 5.5V	●	0.23	0.55	%/V	
		$V^+ = 2.25\text{V}$ to 4.5V	●	0.06	0.16	%/V	
	Long-Term Frequency Stability	(Note 11)		90		ppm/ $\sqrt{\text{kHz}}$	
	Period Jitter (Note 10)	$N_{\text{DIV}} = 1$		0.38		% _{P-P}	
		$N_{\text{DIV}} = 2$		0.22 0.027		% _{P-P} % _{RMS}	
		$N_{\text{DIV}} = 128$		0.022 0.004		% _{P-P} % _{RMS}	
	Duty Cycle	$N_{\text{DIV}} = 1$, $R_{\text{SET}} = 25\text{k}$ to 800k	●	47	50	53	%
		$N_{\text{DIV}} > 1$, $R_{\text{SET}} = 25\text{k}$ to 800k	●	48	50	52	%
BW	Frequency Modulation Bandwidth			$0.4 \cdot f_{\text{OUT}}$		kHz	
t_s	Frequency Change Settling Time (Note 9)	$t_{\text{MASTER}} = t_{\text{OUT}}/N_{\text{DIV}}$		$6 \cdot t_{\text{MASTER}}$		μs	

Analog Inputs

V_{SET}	Voltage at SET Pin		●	0.97	1.00	1.03	V
$\Delta V_{\text{SET}}/\Delta T$	V_{SET} Drift Over Temperature		●		± 75		$\mu\text{V}/^\circ\text{C}$
$\Delta V_{\text{SET}}/\Delta V^+$	V_{SET} Drift Over Supply				-150		$\mu\text{V}/\text{V}$
$\Delta V_{\text{SET}}/\Delta I_{\text{SET}}$	V_{SET} Droop with I_{SET}				-7		Ω
R_{SET}	Frequency-Setting Resistor	Recommended Range	●	50		800	k Ω
		Extended Range	●	25		800	k Ω
V_{DIV}	DIV Pin Voltage		●	0		V^+	V
$\Delta V_{\text{DIV}}/V^+$	DIV Pin Valid Code Range (Note 5)	Deviation from Ideal $V_{\text{DIV}}/V^+ = (\text{DIVCODE} + 0.5)/16$	●			± 1.5	%
		DIV Pin Input Current	●			± 10	nA

Power Supply

V^+	Operating Supply Voltage Range		●	2.25		5.5	V	
	Power-On Reset Voltage	$R_{\text{SET}} = 25\text{k}$ to 800k	●			1.95	V	
I_s	Supply Current	$R_L = \infty$, $N_{\text{DIV}} = 1$, $R_{\text{SET}} = 50\text{k}$	●		$V^+ = 5.5\text{V}$ $V^+ = 2.25\text{V}$	235 145	283 183	μA μA
		$R_L = \infty$, $N_{\text{DIV}} = 1$, $R_{\text{SET}} = 800\text{k}$	●		$V^+ = 5.5\text{V}$ $V^+ = 2.25\text{V}$	71 59	105 92	μA μA
		$R_L = \infty$, $N_{\text{DIV}} = 128$, $R_{\text{SET}} = 50\text{k}$	●		$V^+ = 5.5\text{V}$ $V^+ = 2.25\text{V}$	137 106	180 145	μA μA
		$R_L = \infty$, $N_{\text{DIV}} = 128$, $R_{\text{SET}} = 800\text{k}$	●		$V^+ = 5.5\text{V}$ $V^+ = 2.25\text{V}$	66 56	100 90	μA μA

ELECTRICAL CHARACTERISTICS

The ● denotes the specifications which apply over the full operating temperature range, otherwise specifications are at $T_A = 25^\circ\text{C}$. Test conditions are $V^+ = 2.25\text{V}$ to 5.5V , $\text{OE} = V^+$, $\text{DIVCODE} = 0$ to 15 ($N_{\text{DIV}} = 1$ to 128), $R_{\text{SET}} = 25\text{k}$ to 800k , $R_{\text{LOAD}} = \infty$, $C_{\text{LOAD}} = 5\text{pF}$ unless otherwise noted.

SYMBOL	PARAMETER	CONDITIONS	MIN	TYP	MAX	UNITS
Digital I/O						
	OE Pin Input Capacitance			2.5		pF
	OE Pin Input Current	$\text{OE} = 0\text{V}$ to V^+	●		± 10	nA
V_{IH}	High Level OE Pin Input Voltage	(Note 6)	●	$0.7 \cdot V^+$		V
V_{IL}	Low Level OE Pin Input Voltage	(Note 6)	●		$0.3 \cdot V^+$	V
	OUT Pin Hi-Z Leakage	$\text{OE} = 0\text{V}$, $\text{DIVCODE} \geq 8$, $\text{OUT} = 0\text{V}$ to V^+			± 10	μA
$I_{\text{OUT(MAX)}}$	Maximum Output Current			± 20		mA
V_{OH}	High Level Output Voltage (Note 7)	$V^+ = 5.5\text{V}$	●	5.45	5.48	V
		$I_{\text{OH}} = -1\text{mA}$	●	4.84	5.15	V
		$I_{\text{OH}} = -16\text{mA}$	●			
		$V^+ = 3.3\text{V}$	●	3.24	3.27	V
		$I_{\text{OH}} = -1\text{mA}$	●	2.75	2.99	V
		$I_{\text{OH}} = -10\text{mA}$	●			
V_{OL}	Low Level Output Voltage (Note 7)	$V^+ = 5.5\text{V}$	●	0.02	0.04	V
		$I_{\text{OL}} = 1\text{mA}$	●	0.26	0.54	V
		$I_{\text{OL}} = 16\text{mA}$	●			
		$V^+ = 3.3\text{V}$	●	0.03	0.05	V
		$I_{\text{OL}} = 1\text{mA}$	●	0.22	0.46	V
		$I_{\text{OL}} = 10\text{mA}$	●			
t_{PD}	Output Disable Propagation Delay	$V^+ = 5.5\text{V}$		17		ns
		$V^+ = 3.3\text{V}$		26		ns
		$V^+ = 2.25\text{V}$		44		ns
t_{ENABLE}	Output Enable Time	$N_{\text{DIV}} \leq 2$, $t_{\text{OUT}} = 1/f_{\text{OUT}}$ $N_{\text{DIV}} \geq 4$, $t_{\text{MASTER}} = t_{\text{OUT}}/N_{\text{DIV}}$		t_{PD} to t_{OUT} t_{PD} to $2 \cdot t_{\text{MASTER}}$		μs μs
t_r	Output Rise Time (Note 8)	$V^+ = 5.5\text{V}$		1.1		ns
		$V^+ = 3.3\text{V}$		1.7		ns
		$V^+ = 2.25\text{V}$		2.7		ns
t_f	Output Fall Time (Note 8)	$V^+ = 5.5\text{V}$		1.0		ns
		$V^+ = 3.3\text{V}$		1.6		ns
		$V^+ = 2.25\text{V}$		2.4		ns

Note 1: Stresses beyond those listed under Absolute Maximum Ratings may cause permanent damage to the device. Exposure to any Absolute Maximum Rating condition for extended periods may affect device reliability and lifetime.

Note 2: The LTC6990C is guaranteed functional over the operating temperature range of -40°C to 85°C .

Note 3: The LTC6990C is guaranteed to meet specified performance from 0°C to 70°C . The LTC6990C is designed, characterized and expected to meet specified performance from -40°C to 85°C but it is not tested or QA sampled at these temperatures. The LTC6990I is guaranteed to meet specified performance from -40°C to 85°C . The LTC6990H is guaranteed to meet specified performance from -40°C to 125°C . The LTC6990MP is guaranteed to meet specified performance from -55°C to 125°C .

Note 4: Frequency accuracy is defined as the deviation from the f_{OUT} equation, assuming R_{SET} is used to program the frequency.

Note 5: See Operation section, Table 1 and Figure 2 for a full explanation of how the DIV pin voltage selects the value of DIVCODE.

Note 6: The OE pin has hysteresis to accommodate slow rising or falling signals. The threshold voltages are proportional to V^+ . Typical values can be estimated at any supply voltage using $V_{\text{OE(RISING)}} \approx 0.55 \cdot V^+ + 185\text{mV}$ and $V_{\text{OE(FALLING)}} \approx 0.48 \cdot V^+ - 155\text{mV}$.

Note 7: To conform to the Logic IC Standard, current out of a pin is arbitrarily given a negative value.

Note 8: Output rise and fall times are measured between the 10% and the 90% power supply levels with 5pF output load. These specifications are based on characterization.

Note 9: Settling time is the amount of time required for the output to settle within $\pm 1\%$ of the final frequency after a $0.5x$ or $2x$ change in I_{SET} .

Note 10: Jitter is the ratio of the deviation of the period to the mean of the period. This specification is based on characterization and is not 100% tested.

ELECTRICAL CHARACTERISTICS

Note 11: Long-term drift of silicon oscillators is primarily due to the movement of ions and impurities within the silicon and is tested at 30°C under otherwise nominal operating conditions. Long-term drift is specified as ppm/ $\sqrt{\text{kHr}}$ due to the typically nonlinear nature of the drift. To calculate drift for a set time period, translate that time into thousands of hours, take

the square root and multiply by the typical drift number. For instance, a year is 8.77kHr and would yield a drift of 266ppm at 90ppm/ $\sqrt{\text{kHr}}$. Drift without power applied to the device may be approximated as 1/10th of the drift with power, or 9ppm/ $\sqrt{\text{kHr}}$ for a 90ppm/ $\sqrt{\text{kHr}}$ device.

TYPICAL PERFORMANCE CHARACTERISTICS $V^+ = 3.3V$, unless otherwise noted.

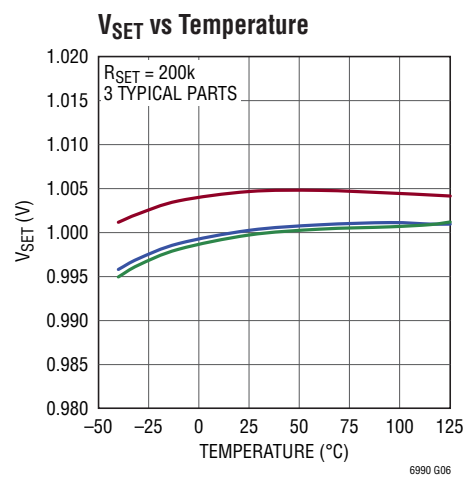
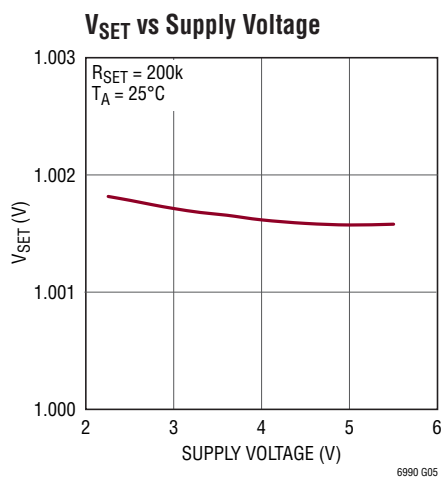
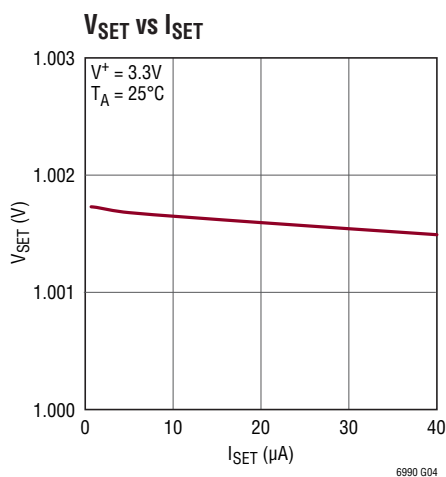
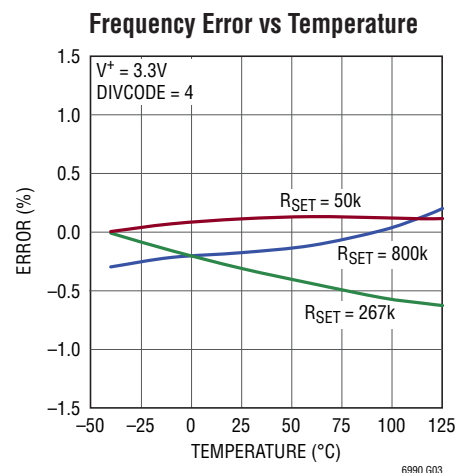
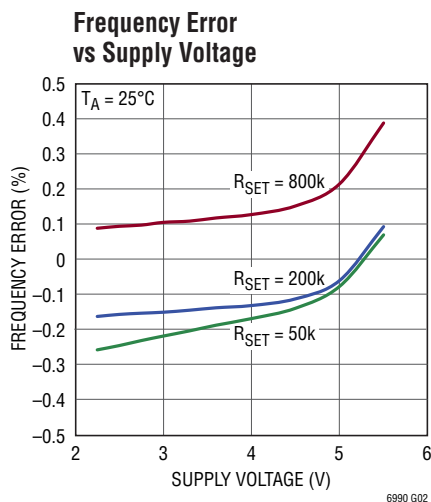
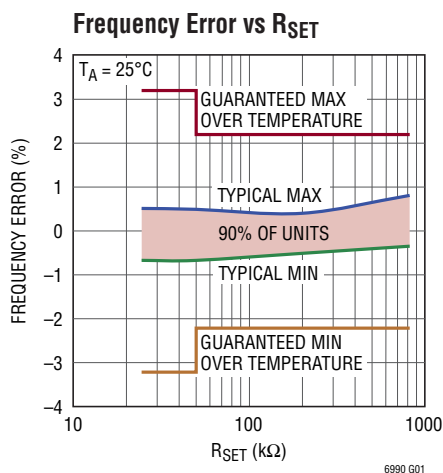

TYPICAL PERFORMANCE CHARACTERISTICS $V^+ = 3V$, unless otherwise noted.

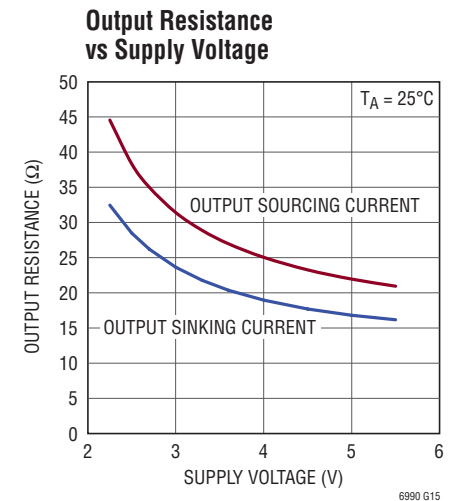
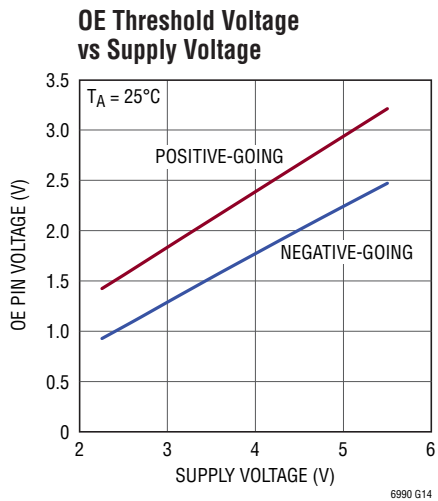
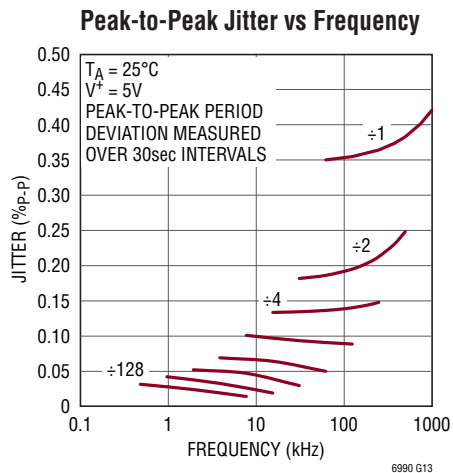
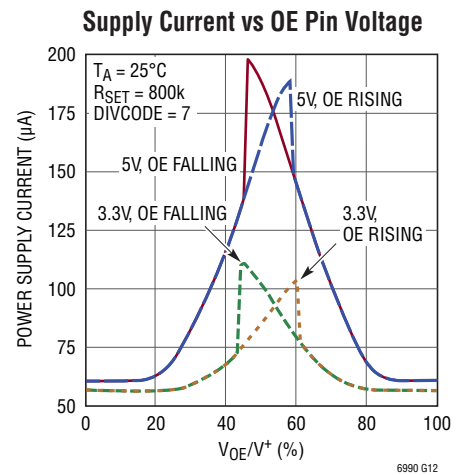
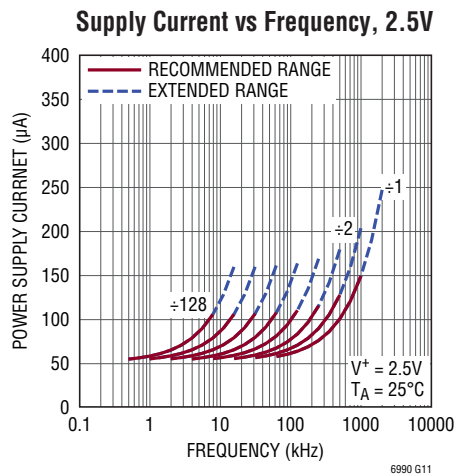
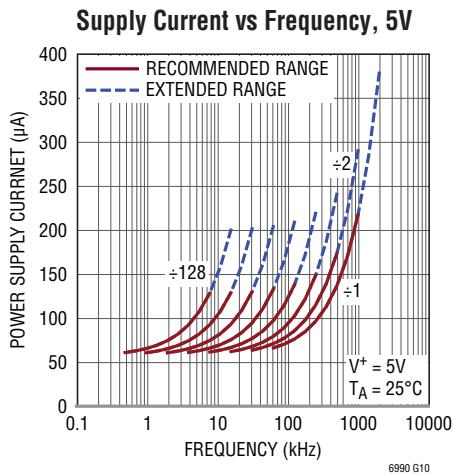
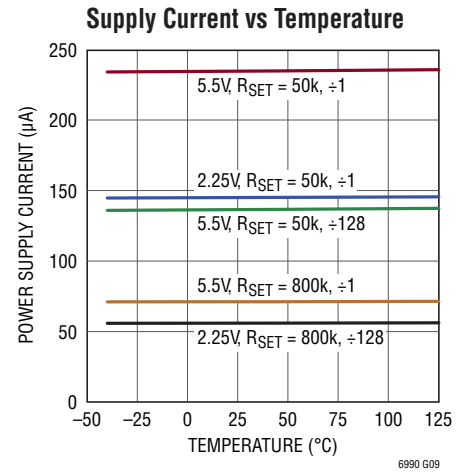
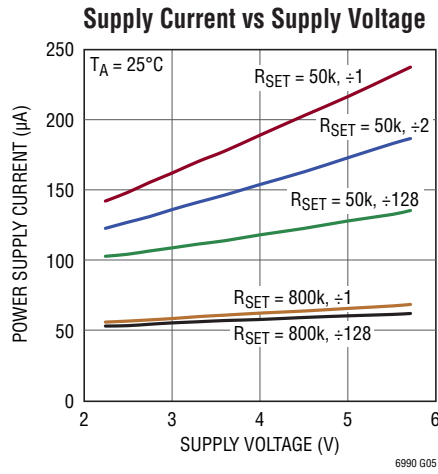
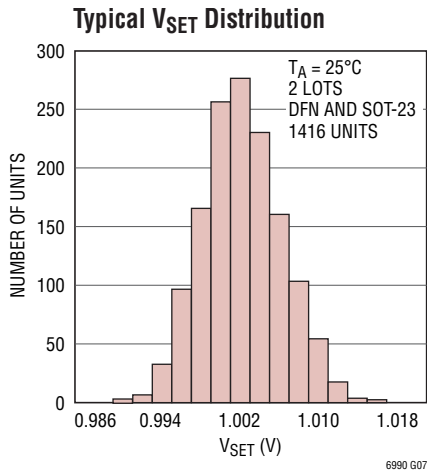

TYPICAL PERFORMANCE CHARACTERISTICS $V^+ = 3V$, unless otherwise noted.

Typical Frequency Error vs Time (Long-Term Drift)

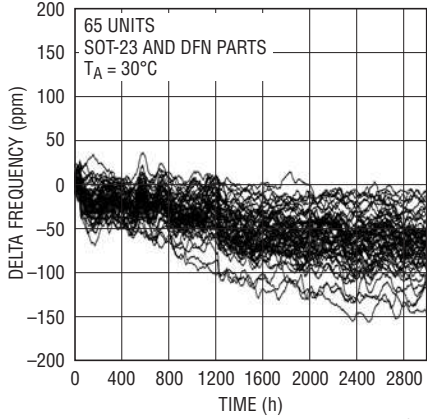

6990 G15a

Rise and Fall Time vs Supply Voltage

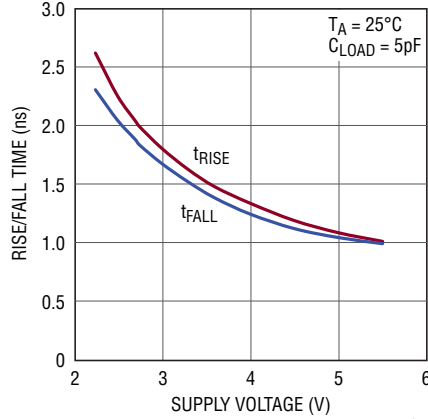

6990 G16

Output Disable Propagation Delay (t_{PD}) vs Supply Voltage

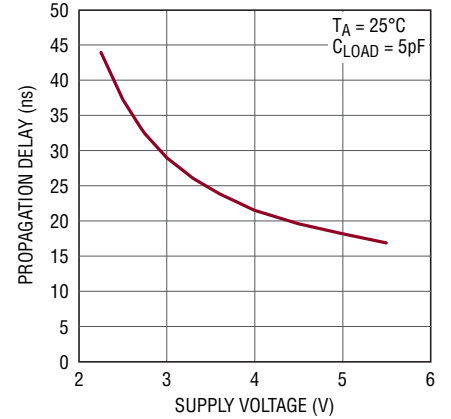

6990 G17

Typical I_{SET} Current Limit vs V⁺

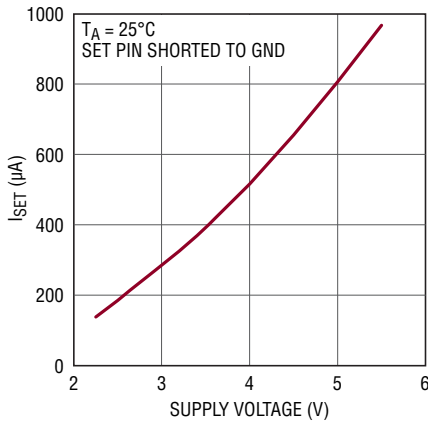

6990 G18

Typical Output Waveform

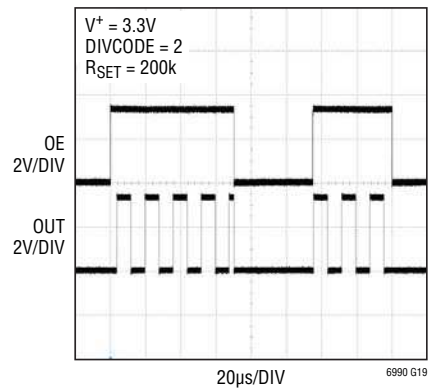

6990 G19

Frequency Modulation

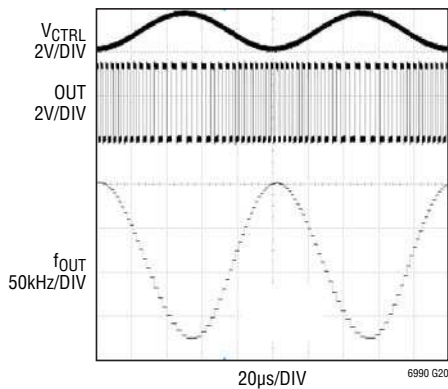

6990 G20

$V^+ = 3.3V$, DIVCODE = 0
 $R_{SET} = 200k$, $R_{VCO} = 464k$
 $f_{OUT} = 175kHz$ to $350kHz$

Frequency Modulation

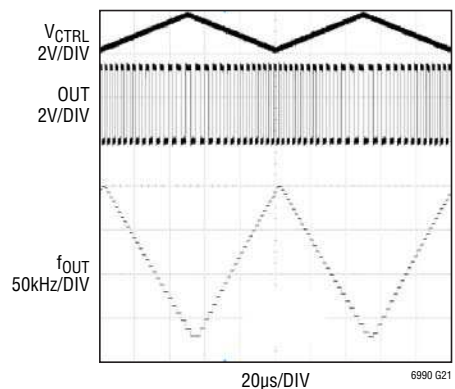

6990 G21

$V^+ = 3.3V$, DIVCODE = 0
 $R_{SET} = 200k$, $R_{VCO} = 464k$
 $f_{OUT} = 175kHz$ to $350kHz$

PIN FUNCTIONS (DCB/S6)

V⁺ (Pin 1/Pin 5): Supply Voltage (2.25V to 5.5V). This supply must be kept free from noise and ripple. It should be bypassed directly to the GND pin with a 0.1μF capacitor.

DIV (Pin 2/Pin 4): Programmable Divider and Hi-Z Mode Input. A V⁺ referenced A/D converter monitors the DIV pin voltage (V_{DIV}) to determine a 4-bit result (DIVCODE). V_{DIV} may be generated by a resistor divider between V⁺ and GND. Use 1% resistors to ensure an accurate result. The DIV pin and resistors should be shielded from the OUT pin or any other traces that have fast edges. Limit the capacitance on the DIV pin to less than 100pF so that V_{DIV} settles quickly. The MSB of DIVCODE (Hi-Z) determines the behavior of the output when OE is driven low. If Hi-Z = 0 the output is pulled low when disabled. If Hi-Z = 1 the output is placed in a high impedance condition when disabled.

SET (Pin 3/Pin 3): Frequency-Setting Input. The voltage on the SET pin (V_{SET}) is regulated to 1V above GND. The amount of current sourced from the SET pin (I_{SET}) programs the master oscillator frequency. The I_{SET} current range is 1.25μA to 40μA. The output oscillation will stop if I_{SET} drops below approximately 500nA. A resistor connected between SET and GND is the most accurate way to set the frequency. For best performance, use a precision metal or thin film resistor of 0.5% or better tolerance and 50ppm/°C or better temperature coefficient. For lower accuracy applications an inexpensive 1% thick film resistor may be used.

Limit the capacitance on the SET pin to less than 10pF to minimize jitter and ensure stability. Capacitance less than 100pF maintains the stability of the feedback circuit regulating the V_{SET} voltage.

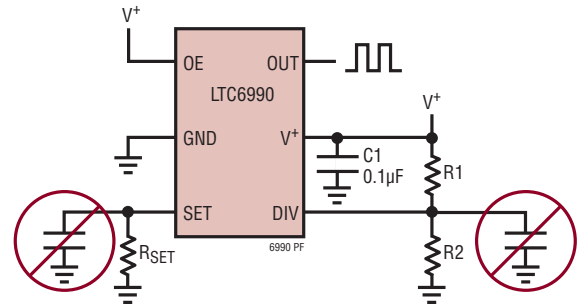

OE (Pin 4/Pin 1): Output Enable. Drive high to enable the output driver (Pin 6). Driving OE low disables the output asynchronously, so that the output is immediately forced low (Hi-Z = 0) or floated (Hi-Z = 1). When enabled, the output may temporarily remain low to synchronize with the internal oscillator in order to eliminate pulse slivers.

GND (Pin 5/Pin 2): Ground. Tie to a low inductance ground plane for best performance.

OUT (Pin 6/Pin 6): Oscillator Output. The OUT pin swings from GND to V⁺ with an output resistance of approximately 30Ω. When driving an LED or other low-impedance load a series output resistor should be used to limit source/sink current to 20mA.

BLOCK DIAGRAM (S6 Package Pin Numbers Shown)

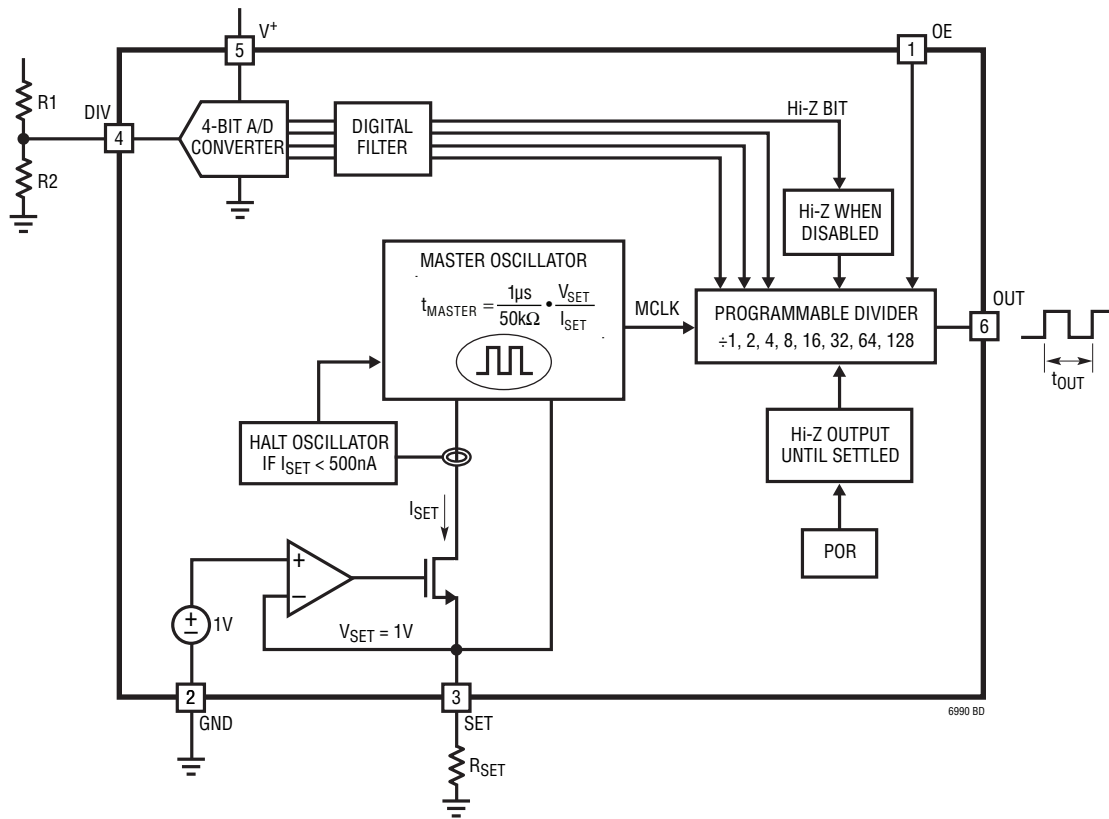

6990 BD

OPERATION

The LTC6990 is built around a master oscillator with a 1MHz maximum frequency. The oscillator is controlled by the SET pin current (I_{SET}) and voltage (V_{SET}), with a $1\text{MHz} \cdot 50\text{k}$ conversion factor that is accurate to $\pm 0.8\%$ under typical conditions.

$$f_{MASTER} = \frac{1}{t_{MASTER}} = 1\text{MHz} \cdot 50\text{k} \cdot \frac{I_{SET}}{V_{SET}}$$

A feedback loop maintains V_{SET} at $1\text{V} \pm 30\text{mV}$, leaving I_{SET} as the primary means of controlling the output frequency. The simplest way to generate I_{SET} is to connect a resistor (R_{SET}) between SET and GND, such that $I_{SET} = V_{SET}/R_{SET}$. The master oscillator equation reduces to:

$$f_{MASTER} = \frac{1}{t_{MASTER}} = \frac{1\text{MHz} \cdot 50\text{k}}{R_{SET}}$$

From this equation it is clear that V_{SET} drift will not affect the output frequency when using a single program resistor (R_{SET}). Error sources are limited to R_{SET} tolerance and the inherent frequency accuracy Δf_{OUT} of the LTC6990.

R_{SET} values between 50k and 800k (equivalent to I_{SET} between $1.25\mu\text{A}$ and $20\mu\text{A}$) produce the best results, although R_{SET} may be reduced to 25k ($I_{SET} = 40\mu\text{A}$) with reduced accuracy.

The LTC6990 includes a programmable frequency divider which can further divide the frequency by 1, 2, 4, 8, 16, 32, 64 or 128 before driving the OUT pin. The divider ratio N_{DIV} is set by a resistor divider attached to the DIV pin.

$$f_{OUT} = \frac{1}{t_{OUT}} = \frac{1\text{MHz} \cdot 50\text{k}}{N_{DIV}} \cdot \frac{I_{SET}}{V_{SET}}$$

With R_{SET} in place of V_{SET}/I_{SET} the equation reduces to:

$$f_{OUT} = \frac{1}{t_{OUT}} = \frac{1\text{MHz} \cdot 50\text{k}}{N_{DIV} \cdot R_{SET}}$$

DIVCODE

The DIV pin connects to an internal, V^+ referenced 4-bit A/D converter that monitors the DIV pin voltage (V_{DIV}) to determine the DIVCODE value. DIVCODE programs two settings on the LTC6990:

1. DIVCODE determines the output frequency divider setting, N_{DIV} .
2. DIVCODE determines the state of the output when disabled, via the Hi-Z bit.

V_{DIV} may be generated by a resistor divider between V^+ and GND as shown in Figure 1.

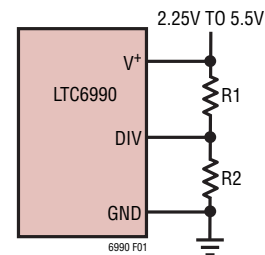

Figure 1. Simple Technique for Setting DIVCODE

OPERATION

Table 1. DIVCODE Programming

DIVCODE	Hi-Z	N _{DIV}	Recommended f _{OUT}	R1 (k)	R2 (k)	V _{DIV} /V ⁺
0	0	1	62.5kHz to 1MHz	Open	Short	≤ 0.03125 ±0.015
1	0	2	31.25kHz to 500kHz	976	102	0.09375 ±0.015
2	0	4	15.63kHz to 250kHz	976	182	0.15625 ±0.015
3	0	8	7.813kHz to 125kHz	1000	280	0.21875 ±0.015
4	0	16	3.906kHz to 62.5kHz	1000	392	0.28125 ±0.015
5	0	32	1.953kHz to 31.25kHz	1000	523	0.34375 ±0.015
6	0	64	976.6Hz to 15.63kHz	1000	681	0.40625 ±0.015
7	0	128	488.3Hz to 7.813kHz	1000	887	0.46875 ±0.015
8	1	128	488.3Hz to 7.813kHz	887	1000	0.53125 ±0.015
9	1	64	976.6Hz to 15.63kHz	681	1000	0.59375 ±0.015
10	1	32	1.953kHz to 31.25kHz	523	1000	0.65625 ±0.015
11	1	16	3.906kHz to 62.5kHz	392	1000	0.71875 ±0.015
12	1	8	7.813kHz to 125kHz	280	1000	0.78125 ±0.015
13	1	4	15.63kHz to 250kHz	182	976	0.84375 ±0.015
14	1	2	31.25kHz to 500kHz	102	976	0.90625 ±0.015
15	1	1	62.5kHz to 1MHz	Short	Open	≥ 0.96875 ±0.015

Table 1 offers recommended 1% resistor values that accurately produce the correct voltage division as well as the corresponding N_{DIV} and Hi-Z values for the recommended resistor pairs. Other values may be used as long as:

1. The V_{DIV}/V⁺ ratio is accurate to ±1.5% (including resistor tolerances and temperature effects)
2. The driving impedance (R1||R2) does not exceed 500kΩ.

If the voltage is generated by other means (i.e. the output of a DAC) it must track the V⁺ supply voltage. The last column in Table 1 shows the ideal ratio of V_{DIV} to the

supply voltage, which can also be calculated as:

$$\frac{V_{DIV}}{V^+} = \frac{DIVCODE + 0.5}{16} \pm 1.5\%$$

For example, if the supply is 3.3V and the desired DIVCODE is 4, V_{DIV} = 0.281 • 3.3V = 928mV ± 50mV.

Figure 2 illustrates the information in Table 1, showing that N_{DIV} is symmetric around the DIVCODE midpoint.

On start-up, the DIV pin A/D converter must determine the correct DIVCODE before the output is enabled. If V_{DIV}

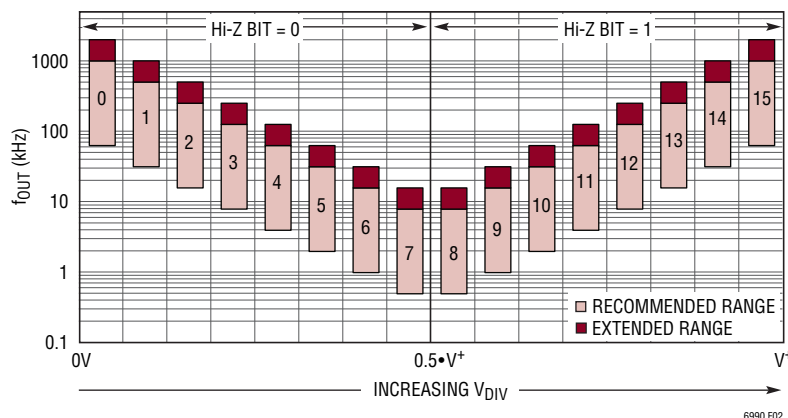
Figure 2. Frequency Range and Hi-Z Bit vs DIVCODE

OPERATION

is not stable, it will increase the start-up time as the converter waits for a stable result. Therefore, capacitance on the DIV pin should be minimized so it will settle quickly. Less than 100pF will not affect performance.

Output Enable

The OE pin controls the state of the LTC6990's output as seen on the OUT pin. Pulling the OE pin high enables the oscillator output. Pulling it low disables the output. When the output is disabled, it is either held low or placed in a high impedance state as dictated by the Hi-Z bit value (determined by the DIVCODE as described earlier). Table 2 summarizes the output control states.

Table 2. Output States

OE Pin	Hi-Z	OUT
1	X	Enabled, Output is Active
0	1	Disabled, Output is Hi-Z
0	0	Disabled, Output is Held Low

Figure 3 illustrates the timing for the OE function when Hi-Z = 0. When OE is low, the output is disabled and OUT is held low. Bringing OE high enables the output after a delay, t_{ENABLE} , which synchronizes the enable to eliminate sliver pulses and guarantee the correct width for the first pulse. If $N_{DIV} = 1$ or 2 this delay will be no longer than the output period, t_{OUT} . If $N_{DIV} > 2$ the delay is limited to twice the internal master oscillator period (or $2 \cdot t_{MASTER}$). Forcing OE low will bring OUT low after a propagation delay, t_{PD} . If the output is high when OE falls, the output pulse will be truncated.

As shown in Figure 4, setting Hi-Z = 1 places the output in a high-impedance state when OE = 0. This feature allows for "wired-OR" connections of multiple devices. Driving OE high enables the output. The output will usually be forced low during this time, although it is possible for OUT to transition directly from high-impedance to a high output, depending on the timing of the OE transition relative to the internal oscillator. Once high, the first output pulse will have the correct width (unless truncated by bringing OE low again).

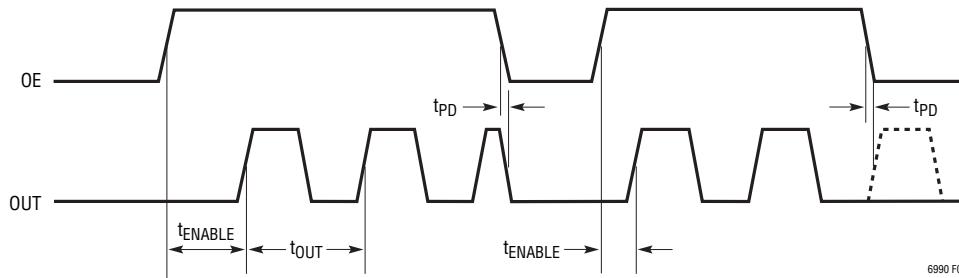

Figure 3. OE Timing Diagram (Hi-Z = 0)

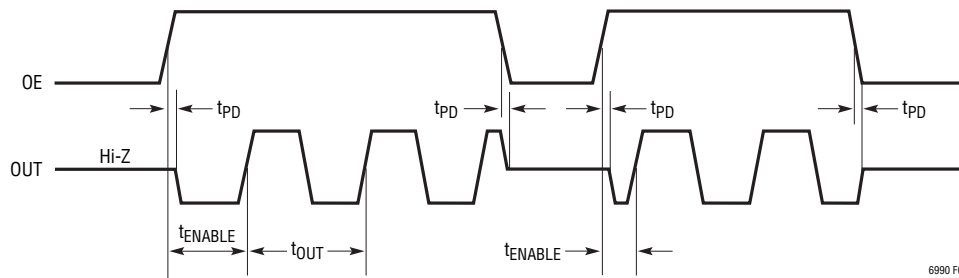

Figure 4. OE Timing Diagram (Hi-Z = 1)

OPERATION

Changing DIVCODE After Start-Up

Following start-up, the A/D converter will continue monitoring V_{DIV} for changes. Changes to DIVCODE will be recognized slowly, as the LTC6990 places a priority on eliminating any “wandering” in the DIVCODE. The typical delay depends on the difference between the old and new DIVCODE settings and is proportional to the master oscillator period.

$$t_{DIVCODE} = 16 \cdot (\Delta DIVCODE + 6) \cdot t_{MASTER}$$

A change in DIVCODE will not be recognized until it is stable, and will not pass through intermediate codes. A digital filter is used to guarantee the DIVCODE has settled to a new value before making changes to the output. Then the output will make a clean (glitchless) transition to the new divider setting.

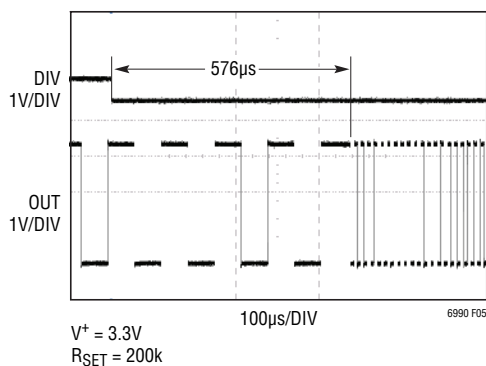

Figure 5. DIVCODE Change from 5 to 2

Start-Up Time

When power is first applied to the LTC6990 the power-on reset (POR) circuit will initiate the start-up time, t_{START} . The OUT pin is floated (high-impedance) during this time. The typical value for t_{START} ranges from 0.5ms to 8ms depending on the master oscillator frequency (independent of N_{DIV}):

$$t_{START(TYP)} = 500 \cdot t_{MASTER}$$

The start-up time may be longer if the supply or DIV pin voltages are not stable. For this reason, it is recommended to minimize the capacitance on the DIV pin so it will properly track V^+ .

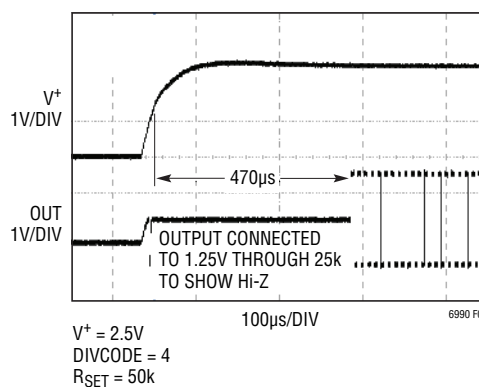

Figure 6. Typical Start-Up

APPLICATIONS INFORMATION

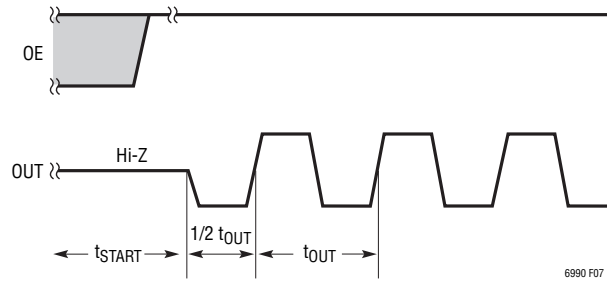

Figure 7. Start-Up Timing Diagram (OE = 1, N_{DIV} = 1 or 2, Hi-Z = 0 or 1)

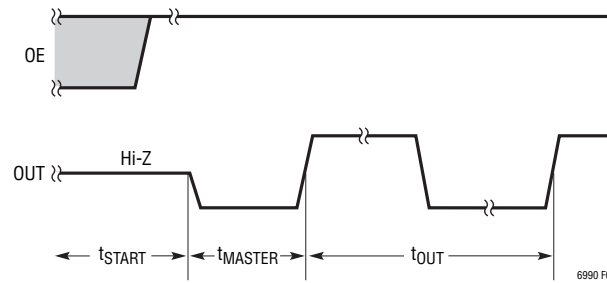

Figure 8. Start-Up Timing Diagram (OE = 1, N_{DIV} ≥ 4, Hi-Z = 0 or 1)

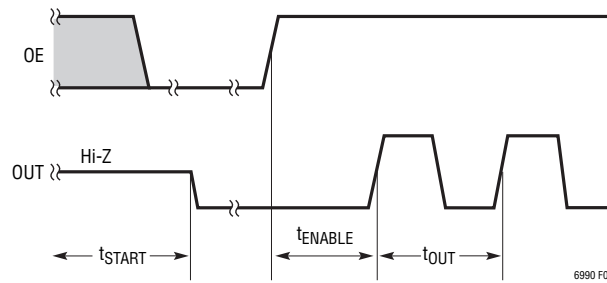

Figure 9. Start-Up Timing Diagram (OE = 0, N_{DIV} = Any, Hi-Z = 0)

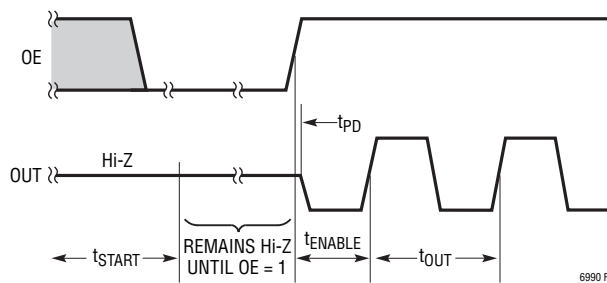

Figure 10. Start-Up Timing Diagram (OE = 0, N_{DIV} = Any, Hi-Z = 1)

APPLICATIONS INFORMATION

Start-Up Behavior

When first powered up, the output is high impedance. If the output is enabled ($OE = 1$) at the end of the start-up time, the output will go low for one t_{MASTER} cycle (or half a t_{OUT} cycle if $N_{DIV} < 4$) before the first rising edge. If the output is disabled ($OE = 0$) at the end of the start-up time, the output will drop to a low output if the Hi-Z bit = 0, or simply remain floating if Hi-Z = 1.

Basic Fixed Frequency Operation

The simplest and most accurate method to program the LTC6990 for fixed frequency operation is to use a single resistor, R_{SET} , between the SET and GND pins. The design procedure is a simple two step process. First select the N_{DIV} value and then calculate the value for the R_{SET} resistor.

Alternatively, Linear Technology offers the easy to use TimerBlox Designer tool to quickly design any LTC6990 based circuit. Download the free TimerBlox Designer software at www.linear.com/timerblox.

Step 1: Selecting the N_{DIV} Frequency Divider Value

As explained earlier, the voltage on the DIV pin sets the DIVCODE which determines both the Hi-Z bit and the N_{DIV} value. For a given output frequency, N_{DIV} should be selected to be within the following range.

$$\frac{62.5\text{kHz}}{f_{OUT}} \leq N_{DIV} \leq \frac{1\text{MHz}}{f_{OUT}} \quad (1a)$$

To minimize supply current, choose the lowest N_{DIV} value (generally recommended). For faster start-up or decreased jitter, choose a higher N_{DIV} setting. Alternatively, use Table 1 as a guide to select the best N_{DIV} value for the given application. After choosing the value for N_{DIV} , use Table 1 to select the proper resistor divider or V_{DIV}/V^+ ratio to apply to the DIV pin.

Step 2: Calculate and Select R_{SET}

The final step is to calculate the correct value for R_{SET} using the following equation.

$$R_{SET} = \frac{1\text{MHz} \cdot 50\text{k}}{N_{DIV} \cdot f_{OUT}} \quad (1b)$$

Select the standard resistor value closest to the calculated value.

Example: Design a 20kHz Oscillator with Minimum Power Consumption

Step 1: Selecting the N_{DIV} Frequency Divider Value

First, choose an N_{DIV} value that meets the requirements of Equation (1a).

$$3.125 \leq N_{DIV} \leq 50$$

Potential settings for N_{DIV} include 4, 8, 16, and 32. $N_{DIV} = 4$ is the best choice, as it minimizes supply current by using a large R_{SET} resistor. Using Table 1, choose the R1 and R2 values to program DIVCODE to either 2 or 13, depending on the desired behavior when the output is disabled.

Step 2: Select R_{SET}

Calculate the correct value for R_{SET} using Equation (1b).

$$R_{SET} = \frac{1\text{MHz} \cdot 50\text{k}}{4 \cdot 20\text{kHz}} = 625\text{k}$$

Since 625k is not available as a standard 1% resistor, substitute 619k if a 0.97% frequency shift is acceptable. Otherwise, select a parallel or series pair of resistors such as 309k and 316k to attain a more precise resistance.

APPLICATIONS INFORMATION

Frequency Modulated Operation (Voltage-Controlled Oscillator)

Operating the LTC6990 as a voltage-controlled oscillator in its simplest form is achieved with one additional resistor. As shown in Figure 11, voltage V_{CTRL} sources/sinks a current through R_{VCO} to vary the I_{SET} current, which in turn modulates the output frequency as described in Equation (2).

$$f_{OUT} = \frac{1\text{MHz} \cdot 50\text{k}}{N_{DIV} \cdot R_{VCO}} \cdot \left(1 + \frac{R_{VCO}}{R_{SET}} - \frac{V_{CTRL}}{V_{SET}} \right) \quad (2)$$

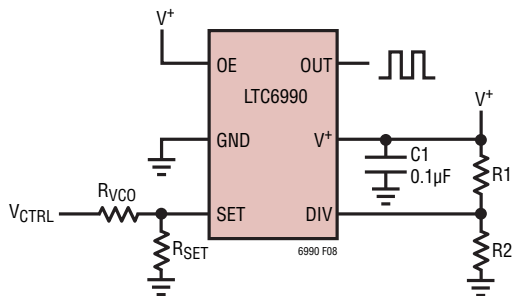

Figure 11. Voltage Controlled Oscillator

Equation (2) can be re-written as shown below, where $f_{(0V)}$ is the output frequency when $V_{CTRL} = 0V$, and K_{VCO} is the frequency gain. Note that the gain is negative (the output frequency decreases as V_{CTRL} increases).

$$f_{OUT} = f_{(0V)} - K_{VCO} \cdot V_{CTRL}$$

$$f_{(0V)} = \frac{1\text{MHz} \cdot 50\text{k}}{N_{DIV} \cdot (R_{SET} \parallel R_{VCO})}$$

$$K_{VCO} = \frac{1\text{MHz} \cdot 50\text{k}}{N_{DIV} \cdot V_{SET} \cdot R_{VCO}}$$

The design procedure for a VCO is a simple four step process. First select the N_{DIV} value. Then calculate the intermediate values K_{VCO} and $f_{(0V)}$. Next, calculate and select the R_{VCO} resistor. Finally calculate and select the R_{SET} resistor.

Step 1: Select the N_{DIV} Frequency Divider Value

For best accuracy, the master oscillator frequency should fall between 62.5kHz and 1MHz. Since $f_{MASTER} = N_{DIV} \cdot$

f_{OUT} , choose a value for N_{DIV} that meets the following conditions

$$\frac{62.5\text{kHz}}{f_{OUT(MIN)}} \leq N_{DIV} \leq \frac{1\text{MHz}}{f_{OUT(MAX)}} \quad (3a)$$

The 16:1 frequency range of the master oscillator and the 2:1 divider step-size provides several overlapping frequency spans to guarantee that any 8:1 modulation range can be covered by a single N_{DIV} setting. R_{VCO} allows the gain to be tailored to the application, mapping the V_{CTRL} voltage range to the modulation range.

Step 2: Calculate K_{VCO} and $f_{(0V)}$

K_{VCO} and $f_{(0V)}$ define the VCO's transfer function and simplify the calculation of the R_{VCO} and R_{SET} resistors. Calculate these parameters using the following equations.

$$K_{VCO} = \frac{f_{OUT(MAX)} - f_{OUT(MIN)}}{V_{CTRL(MAX)} - V_{CTRL(MIN)}} \quad (3b)$$

$$f_{(0V)} = f_{OUT(MAX)} + K_{VCO} \cdot V_{CTRL(MIN)} \quad (3c)$$

K_{VCO} and $f_{(0V)}$ are not device settings or resistor values themselves. However, beyond their utility for the resistor calculations, these parameters provide a useful and intuitive way to look at the VCO application. The $f_{(0V)}$ parameter is the output frequency when V_{CTRL} is at 0V. Viewed another way, it is the fixed output frequency when the R_{VCO} and R_{SET} resistors are in parallel. K_{VCO} is actually the frequency gain of the circuit.

With K_{VCO} and $f_{(0V)}$ determined, the R_{VCO} and R_{SET} values can now be calculated.

Step 3: Calculate and Select R_{VCO}

The next step is to calculate the correct value for R_{VCO} using the following equation.

$$R_{VCO} = \frac{1\text{MHz} \cdot 50\text{k}}{N_{DIV} \cdot V_{SET} \cdot K_{VCO}} \quad (3d)$$

Select the standard resistor value closest to the calculated value.

APPLICATIONS INFORMATION

Step 4: Calculate and Select R_{SET}

The final step is to calculate the correct value for R_{SET} using the following equation:

$$R_{SET} = \frac{1\text{MHz} \cdot 50\text{k}}{N_{DIV} \cdot (f_{(0V)} - V_{SET} \cdot K_{VCO})} \quad (3e)$$

Select the standard resistor value closest to the calculated value.

Some applications require combinations of $f_{OUT(MIN)}$, $f_{OUT(MAX)}$, $V_{CTRL(MIN)}$ and $V_{CTRL(MAX)}$ that are not achievable. These applications result in unrealistic or unrealizable (e.g. negative value) resistors. These applications will require preconditioning of the V_{CTRL} signal via range scaling and/or level shifting to place the V_{CTRL} into a range that yields realistic resistor values.

Frequency Error in VCO Applications Due to V_{SET} Error

As stated earlier, $f_{(0V)}$ represents the frequency for $V_{CTRL} = 0V$, which is the same value as would be generated by a single resistor between SET and GND with a value of $R_{SET} \parallel R_{VCO}$. Therefore, $f_{(0V)}$ is not affected by error or drift in V_{SET} (i.e. ΔV_{SET} adds no frequency error when $V_{CTRL} = 0V$).

The accuracy of K_{VCO} *does* depend on V_{SET} because the output frequency is controlled by the ratio of V_{CTRL} to V_{SET} . The frequency error (in Hertz) due to ΔV_{SET} is approximated by:

$$\Delta f_{OUT} \cong K_{VCO} \cdot V_{CTRL} \cdot \frac{\Delta V_{SET}}{V_{SET}}$$

As the equation indicates, the potential for error in output frequency due to V_{SET} error increases with K_{VCO} and is at its largest when V_{CTRL} is at its maximum. Recall that when V_{CTRL} is at its maximum, the output frequency is at its minimum. With the maximum absolute frequency error (in Hertz) occurring at the lowest output frequency, the relative frequency error (in percent) can be significant.

V_{SET} is nominally 1.0V with a maximum error of $\pm 30\text{mV}$ for at most a $\pm 3\%$ error term. However, this $\pm 3\%$ potential error term is multiplied by both V_{CTRL} and K_{VCO} .

Wide frequency range applications (high K_{VCO}) can have frequency errors greater than $\pm 50\%$ at the highest V_{CTRL} voltage (lowest f_{OUT}). For this reason the simple, two resistor VCO circuit must be used with caution for applications where the frequency range is greater than 4:1. Restricting the range to 4:1 typically keeps the frequency error due to V_{SET} variation below 10%.

For wide frequency range applications, the non-inverting VCO circuit shown in Figure 13 is preferred because the maximum frequency error occurs when the frequency is highest, keeping the relative error (in percent) much smaller.

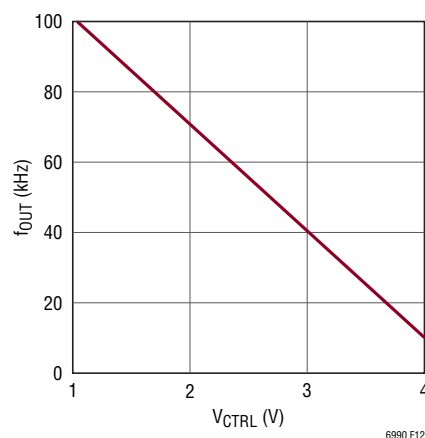

Figure 12. VCO Transfer Function

Example: Design a VCO with the Following Parameters

$$f_{OUT(MAX)} = 100\text{kHz at } V_{CTRL(MIN)} = 1V$$

$$f_{OUT(MIN)} = 10\text{kHz at } V_{CTRL(MAX)} = 4V$$

Step 1: Select the N_{DIV} Value

First, choose an N_{DIV} that meets the requirements of Equation (3a).

$$6.25 \leq N_{DIV} \leq 10$$

The application's desired frequency range is 10:1, which isn't always possible. However, in this case $N_{DIV} = 8$ meets both requirements of Equation (3).

APPLICATIONS INFORMATION

Step 2: Calculate K_{VCO} and $f_{(OV)}$

Next, calculate the intermediate values K_{VCO} and $f_{(OV)}$ using Equations (3b) and (3c).

$$K_{VCO} = \frac{100\text{kHz} - 10\text{kHz}}{4\text{V} - 1\text{V}} = 30\text{kHz/V}$$

$$f_{(OV)} = 100\text{kHz} + 30\text{kHz/V} \cdot 1\text{V} = 130\text{kHz}$$

Step 3: Calculate and Select R_{VCO}

The next step is to use Equation (3d) to calculate the correct value for R_{VCO} .

$$R_{VCO} = \frac{1\text{MHz} \cdot 50\text{k}}{8 \cdot 1\text{V} \cdot 30\text{kHz/V}} = 208.333\text{k}$$

Select $R_{VCO} = 210\text{k}$.

Step 4: Calculate and Select R_{SET}

The final step is to calculate the correct value for R_{SET} using Equation (3e).

$$R_{SET} = \frac{1\text{MHz} \cdot 50\text{k}}{8 \cdot (130\text{kHz} - 1\text{V} \cdot 30\text{kHz/V})} = 62.5\text{k}$$

Select $R_{SET} = 61.9\text{k}$

In this design example, with its wide 10:1 frequency range, the potential output frequency error due to V_{SET} error alone ranges from less than $\pm 1\%$ when V_{CTRL} is at its minimum up to $\pm 36\%$ when V_{CTRL} is at its maximum. This error must be accounted for in the system design.

Depending on the application's requirements, the non-inverting VCO circuit in Figure 13 may be preferred for this wide of a frequency variation as its maximum inaccuracy due to V_{SET} error is only $\pm 9\%$ and can be reduced to only $\pm 3\%$ with a small change to the voltage tuning range specification.

Reducing V_{SET} Error Effects in VCO Applications

Figure 13 shows a VCO that reduces the effect of ΔV_{SET} by adding an op-amp to make V_{CTRL} dependent on V_{SET} . This circuit also has a positive transfer function (the output frequency increases as V_{IN} increases). Furthermore, for positive V_{IN} voltages, this circuit places the greatest absolute frequency error at the highest output frequency. Compared to the simple VCO circuit of Figure 11, the absolute frequency error is unchanged. However, with the maximum absolute frequency error (in Hertz) now occurring at the highest output frequency, the relative frequency error (in percent) is greatly improved.

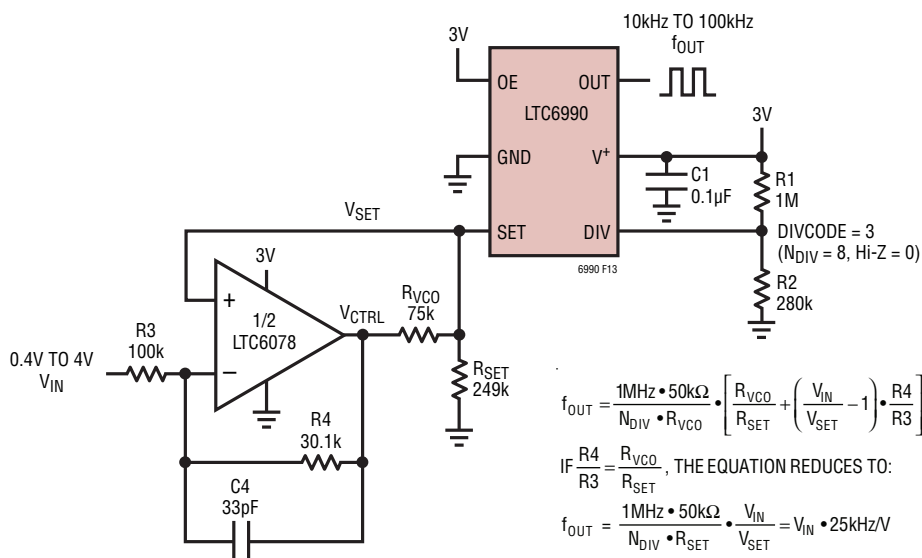

Figure 13. VCO with Reduced ΔV_{SET} Sensitivity

APPLICATIONS INFORMATION

Modulation Bandwidth and Settling Time

The LTC6990 will respond to changes in I_{SET} up to a -3dB bandwidth of $0.4 \cdot f_{OUT}$ (see Figure 15). This makes it easy to stabilize a feedback loop around the LTC6990, since it does not introduce a low-frequency pole.

Settling time depends on the master oscillator frequency. Following a $2\times$ or $0.5\times$ step change in I_{SET} , the output frequency takes approximately six master clock cycles ($6 \cdot t_{MASTER}$) to settle to within 1% of the final value. An example is shown in Figure 16.

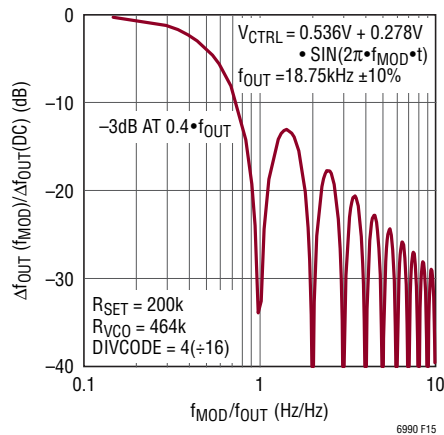

Figure 15. Modulation Frequency Response

Power Supply Current

The power supply current varies with frequency, supply voltage and output loading. It can be estimated under any condition using the following equation:

$$I_{S(TYP)} \approx V^+ \cdot f_{MASTER} \cdot 7\text{pF} + V^+ \cdot f_{OUT} \cdot (13\text{pF} + C_{LOAD}) + \frac{V^+}{480\text{k}\Omega} + \frac{V^+}{2 \cdot R_{LOAD}} + 1.75 \cdot I_{SET} + 50\mu\text{A}$$

The equation is also valid for $OE = 0$ (output disabled), with $f_{OUT} = 0\text{Hz}$.

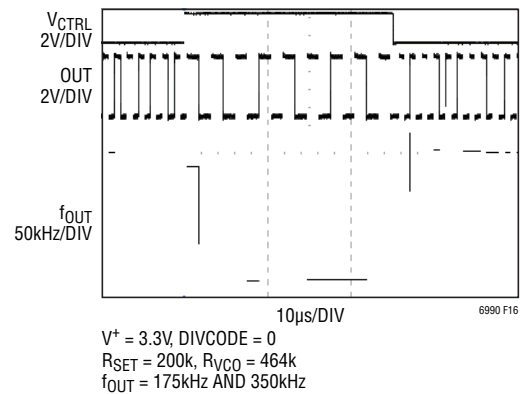

Figure 16. Settling Time

APPLICATIONS INFORMATION

SUPPLY BYPASSING AND PCB LAYOUT GUIDELINES

The LTC6990 is a 2.2% accurate silicon oscillator when used in the appropriate manner. The part is simple to use and by following a few rules, the expected performance is easily achieved. The most important use issues involve adequate supply bypassing and proper PCB layout.

Figure 17 shows example PCB layouts for both the SOT-23 and DCB packages using 0603 sized passive components. The layouts assume a two layer board with a ground plane layer beneath and around the LTC6990. These layouts are a guide and need not be followed exactly.

1. Connect the bypass capacitor, C1, directly to the V⁺ and GND pins using a low inductance path. The connection from C1 to the V⁺ pin is easily done directly on the top layer. For the DCB package, C1's connection to GND is also simply done on the top layer. For the SOT-23, OUT can be routed through the C1 pads to allow a good C1 GND connection. If the PCB design rules do not allow that, C1's GND connection can be accomplished through multiple vias to the ground plane. Multiple vias for both the GND pin connection to the ground plane and the
- C1 connection to the ground plane are recommended to minimize the inductance. Capacitor C1 should be a 0.1 μ F ceramic capacitor.
2. Place all passive components on the top side of the board. This minimizes trace inductance.
3. Place R_{SET} as close as possible to the SET pin and make a direct, short connection. The SET pin is a current summing node and currents injected into this pin directly modulate the operating frequency. Having a short connection minimizes the exposure to signal pickup.
4. Connect R_{SET} directly to the GND pin. Using a long path or vias to the ground plane will not have a significant affect on accuracy, but the direct, short connection is recommended and easy to apply.
5. Use a ground trace to shield the SET pin. This provides another layer of protection from radiated signals.
6. Place R1 and R2 close to the DIV pin. A direct, short connection to the DIV pin minimizes the external signal coupling.

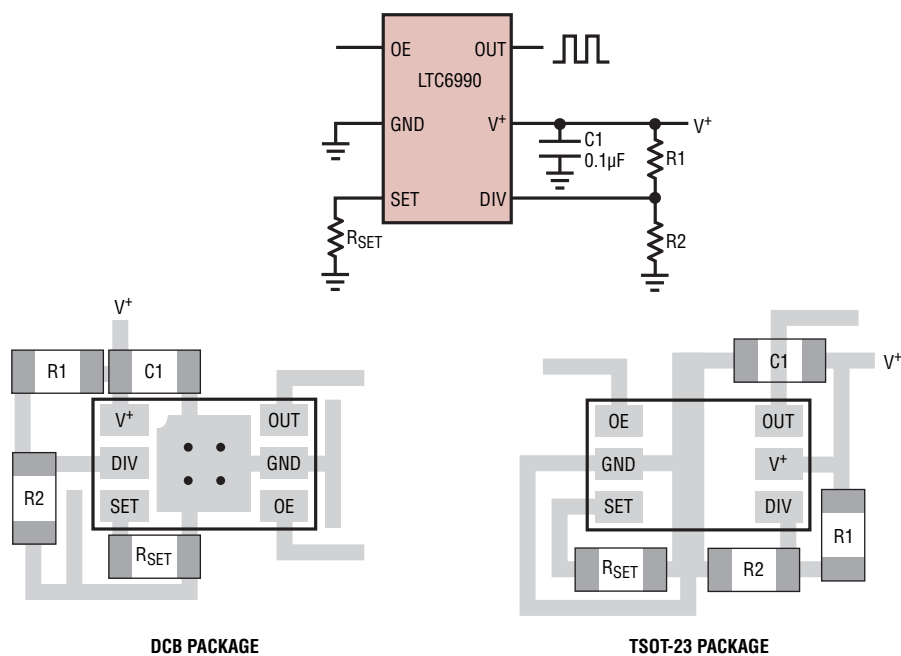
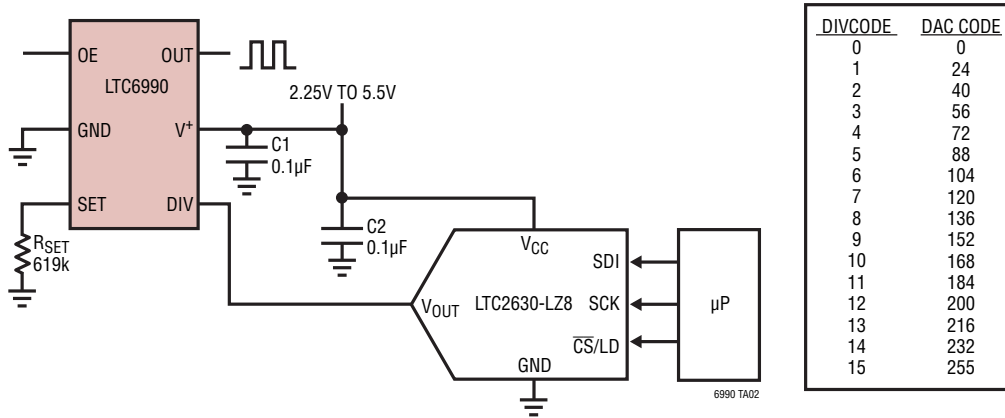

Figure 17. Supply Bypassing and PCB Layout

6990 F17

TYPICAL APPLICATIONS

Programming N_{DIV} Using an 8-Bit DAC



Full Range VCO with Any N_{DIV} Setting (f_{MAX} to f_{MIN} for $V_{IN} = 0V$ to V_{SET})

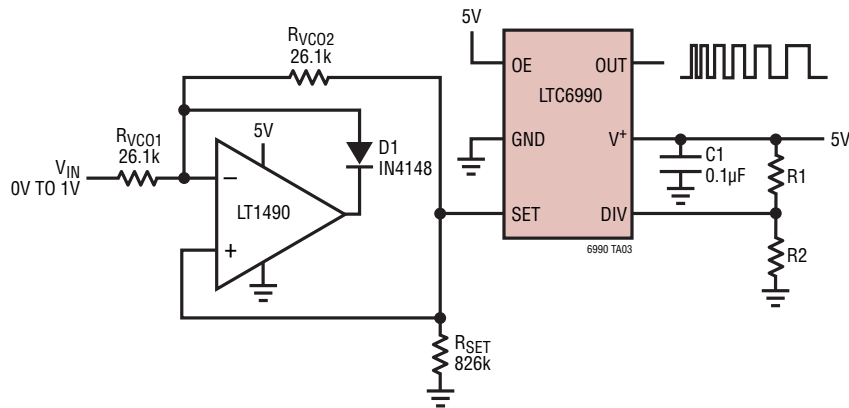

Full Range VCO with Any N_{DIV} Setting (Positive Frequency Control, f_{MIN} to f_{MAX} for $V_{IN} = 0V$ to V_{SET})

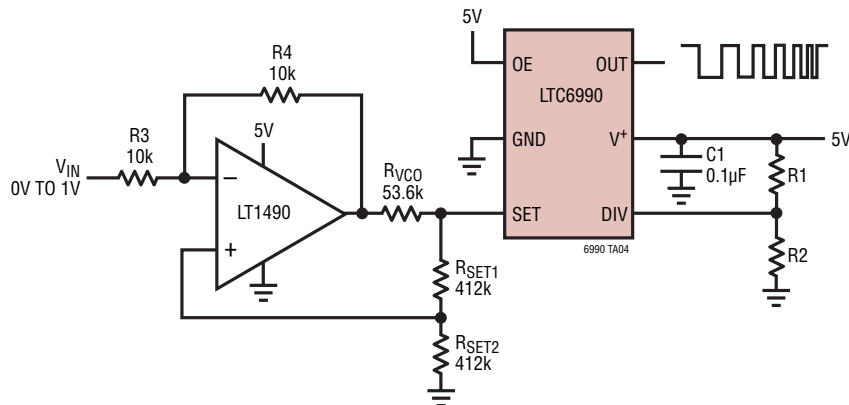

TYPICAL APPLICATIONS

Speaker Alarm. Modulate Tone with R_{VCO} within 500Hz to 8kHz Span

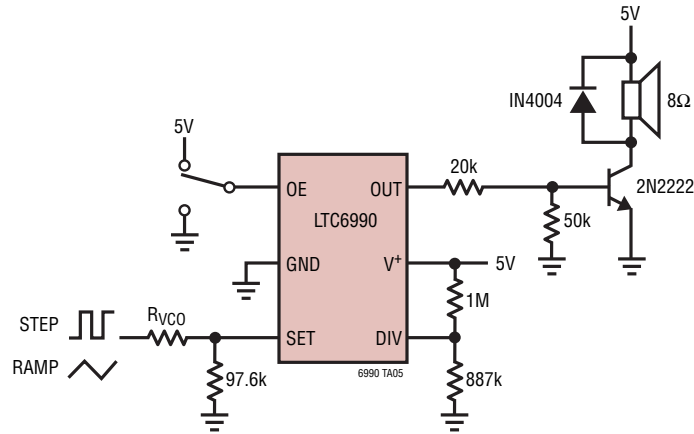

Overvoltage Detector/Alarm. Direct Drive of Piezo Alarm

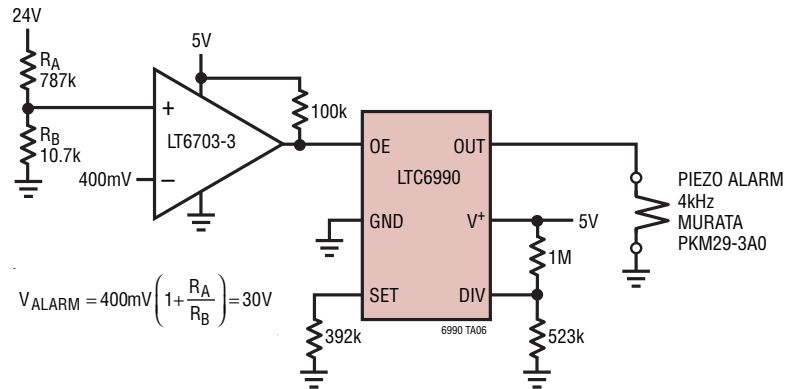

TYPICAL APPLICATIONS

Direct Piezo Alarm Driver. Adjust Frequency for Maximum Alarm Sound Pressure (Maximum Annoyance for Best Effect)

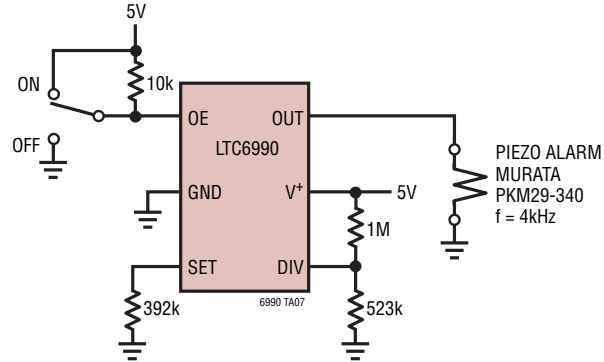

Isolated $V \rightarrow F$ Converter. V_{IN} Provided by Isolated Measurement Circuit. $5\mu s$ Rise/Fall Time of Isolator Limits f_{MAX} to 60kHz

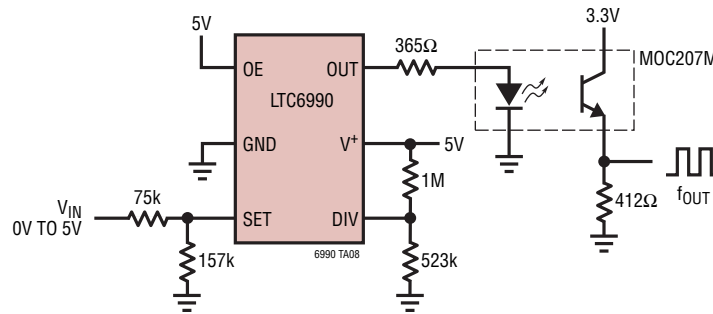

TYPICAL APPLICATIONS

Quadrature Sine Wave Oscillator. Voltage Controlled Frequency Range from 2Hz to 18kHz with 1V_{p-p} Constant Output Amplitude

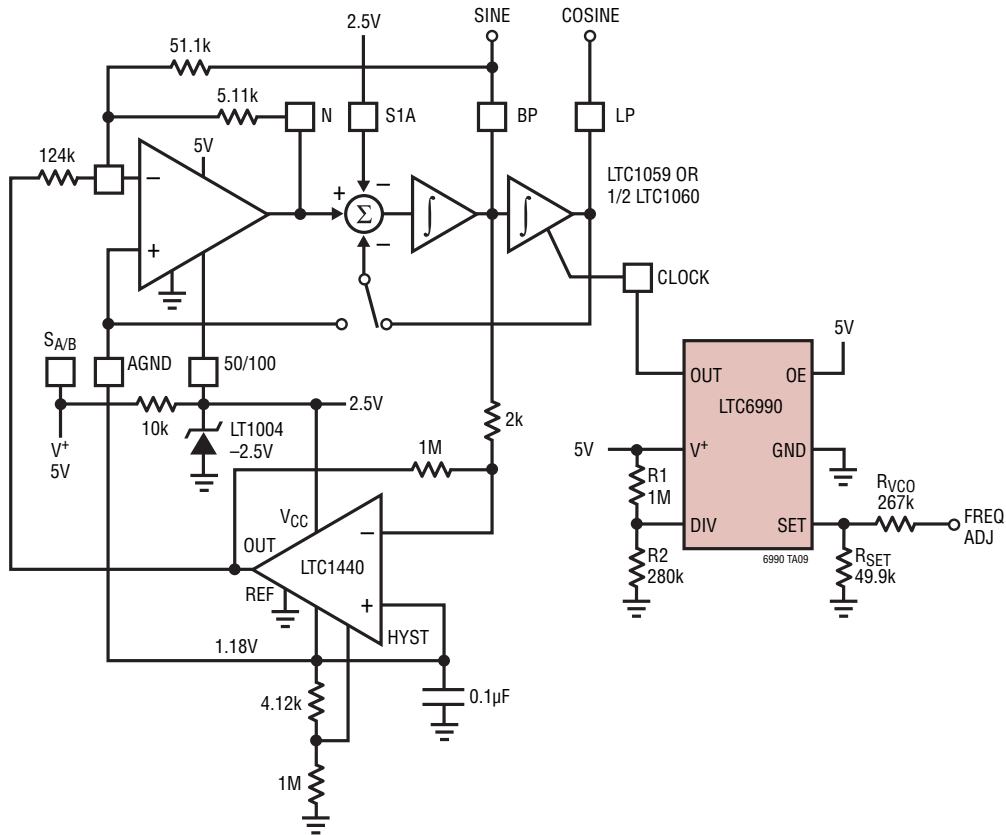

Temperature to Frequency Converter. 3% Linearity from -20°C (f_{OUT} ≈ 20kHz) to 75°C (f_{OUT} ≈ 25kHz)

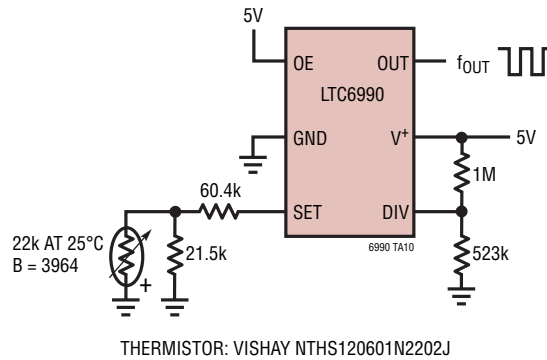

TYPICAL APPLICATIONS

Full Range Temperature to Frequency Converter. 16kHz to 1kHz from -20°C to 80°C

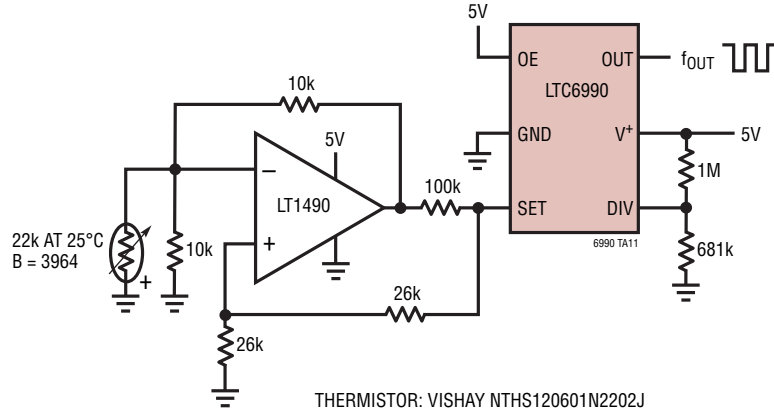

Light to Frequency Converter. $f_{OUT} \approx -1.4\text{kHz per Microampere of Photo Diode Current, } I_{PD}$

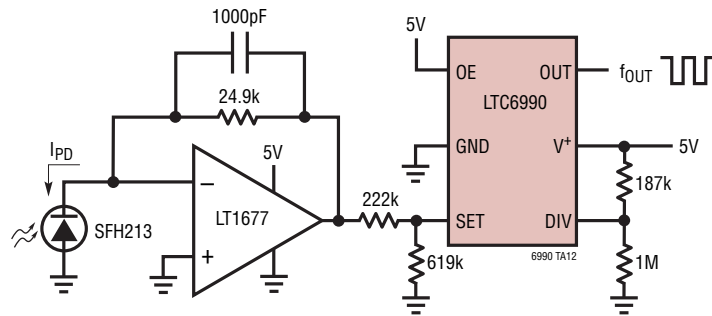

PACKAGE DESCRIPTION

Please refer to <http://www.linear.com/designtools/packaging/> for the most recent package drawings.

S6 Package 6-Lead Plastic TSOT-23 (Reference LTC DWG # 05-08-1636)

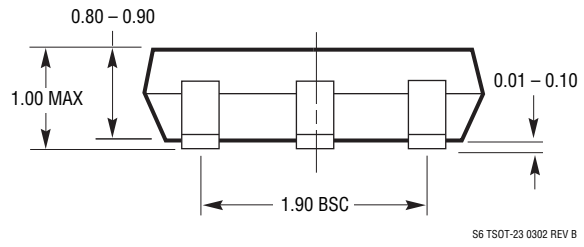
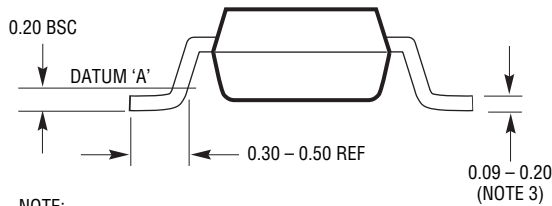
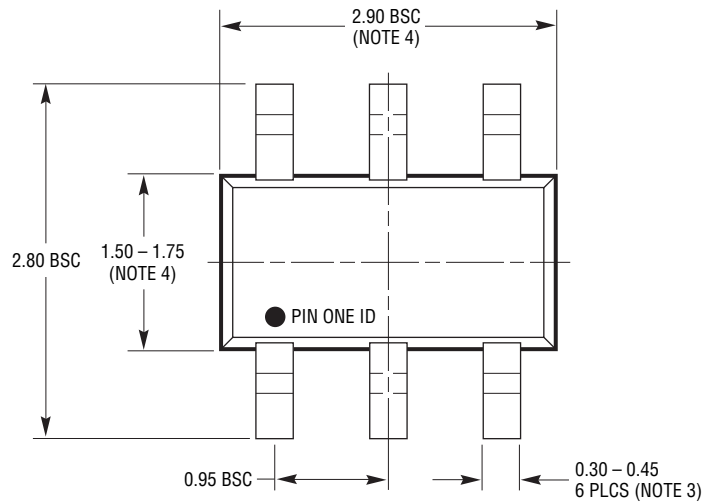
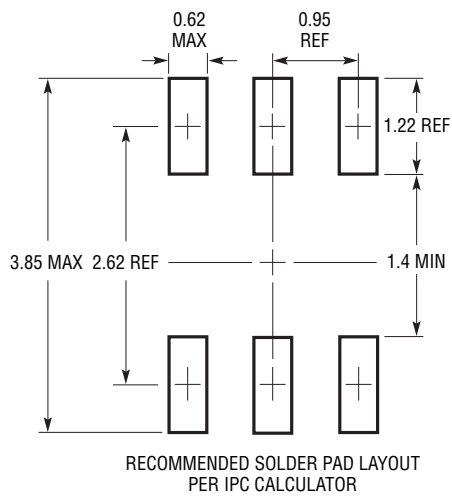

- NOTE:
1. DIMENSIONS ARE IN MILLIMETERS
 2. DRAWING NOT TO SCALE
 3. DIMENSIONS ARE INCLUSIVE OF PLATING
 4. DIMENSIONS ARE EXCLUSIVE OF MOLD FLASH AND METAL BURR
 5. MOLD FLASH SHALL NOT EXCEED 0.254mm
 6. JEDEC PACKAGE REFERENCE IS MO-193

S6 TSOT-23 0302 REV B

REVISION HISTORY

REV	DATE	DESCRIPTION	PAGE NUMBER
A	7/11	Updated Features, Description, Pin Configuration, and Order Information sections	1, 2
		Added additional information to $\Delta f_{OUT}/\Delta V^+$ and included Note 11 in Electrical Characteristics section	3, 4
		Added Typical Frequency Error vs Time curve to Typical Performance Characteristics section	7
		Modified drawing in SET pin description in Pin Functions	8
		Added text to Basic Fixed Frequency Operation paragraph in Applications Information section	15
		Updated Related Parts list	30
B	01/12	Added MP-grade	1, 2, 4

TYPICAL APPLICATION

Ultrasonic Frequency Sweep Generator

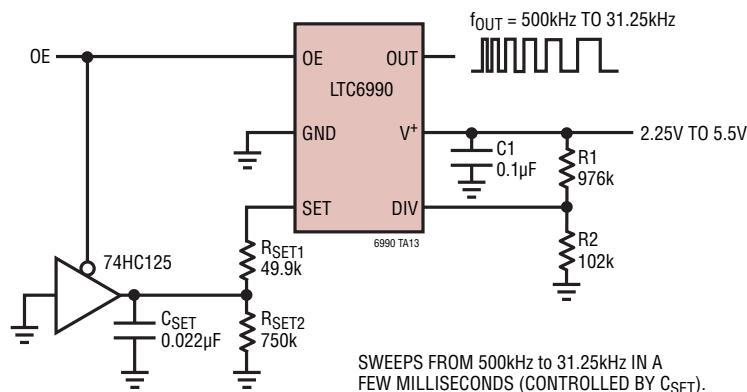

RELATED PARTS

PART NUMBER	DESCRIPTION	COMMENTS
LTC1799	1MHz to 33MHz ThinSOT Silicon Oscillator	Wide Frequency Range
LTC6900	1MHz to 20MHz ThinSOT Silicon Oscillator	Low Power, Wide Frequency Range
LTC6906/LTC6907	10kHz to 1MHz or 40kHz ThinSOT Silicon Oscillator	Micropower, I _{SUPPLY} = 35µA at 400kHz
LTC6930	Fixed Frequency Oscillator, 32.768kHz to 8.192MHz	0.09% Accuracy, 110µs Start-Up Time, 105µA at 32kHz
LTC6991	TimerBlox, Very Low Frequency Clock with Reset	Cycle Time from 2ms to 9.5 Hours, No Caps, 2.2% Accurate
LTC6992	TimerBlox, Voltage-Controlled Pulse Width Modulator (PWM)	Simple PWM with Wide Frequency Range
LTC6993	TimerBlox, Monostable Pulse Generator	Resistor Set Pulse Width from 1µs to 34sec, No Caps, 3% Accurate
LTC6994	TimerBlox, Delay Block/Debouncer	Resistor Set Delay from 1µs to 34sec, No Caps Required, 3% Accurate