

FEATURES

- Maximum Initial Tolerance: 0.2%
- *Guaranteed* Temperature Stability
- Maximum 0.6Ω Dynamic Impedance
- Wide Operating Current Range
- Directly Interchangeable with LM136 for Improved Performance
- No Adjustments Needed for Minimum Temperature Coefficient
- Available in 8-Lead SO and MSOP Packages and 3-Lead TO-92 Package

APPLICATIONS

- Reference for 5V Systems
- 8-Bit A/D and D/A Reference
- Digital Voltmeters
- Current Loop Measurement and Control Systems
- Power Supply Monitor

DESCRIPTION

The LT[®]1009 is a precision trimmed 2.5V shunt regulator diode featuring a maximum initial tolerance of only ±5mV. The low dynamic impedance and wide operating current range enhances its versatility. The 0.2% reference tolerance is achieved by on-chip trimming which not only minimizes the initial voltage tolerance but also minimizes the temperature drift.

Even though no adjustments are needed with the LT1009, a third terminal allows the reference voltage to be adjusted ±5% to calibrate out system errors. In many applications, the LT1009 can be used as a pin-to-pin replacement of the LM136 and the external trim network eliminated.

For a lower drift 2.5V reference, see the LT1019 data sheet.

LT, LT, LTC and LTM are registered trademarks of Linear Technology Corporation. All other trademarks are the property of their respective owners.

TYPICAL APPLICATION

2.5V Reference

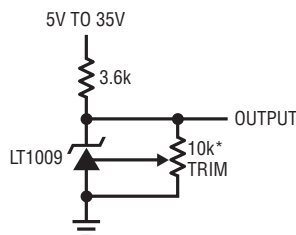

*DOES NOT AFFECT TEMPERATURE COEFFICIENT. ±5% TRIM RANGE

1009 TA01

Output Voltage

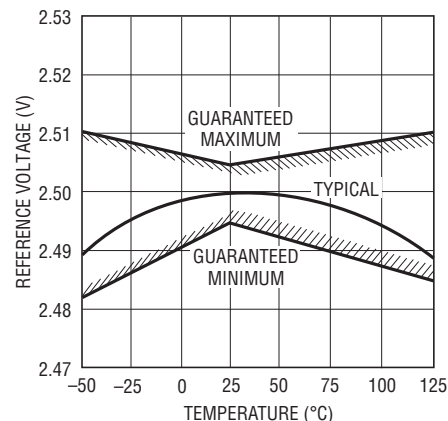

1009 TA02

LT1009 Series

ABSOLUTE MAXIMUM RATINGS (Note 1)

Reverse Current 20mA
 Forward Current 10mA
 Storage Temperature Range -65°C to 150°C
 Lead Temperature (Soldering, 10 sec) 300°C

Operating Temperature Range
 LT1009/LT1009C 0°C to 70°C
 LT1009I -40°C to 85°C
 LT1009M (**OBSOLETE**) -55°C to 125°C

PIN CONFIGURATION

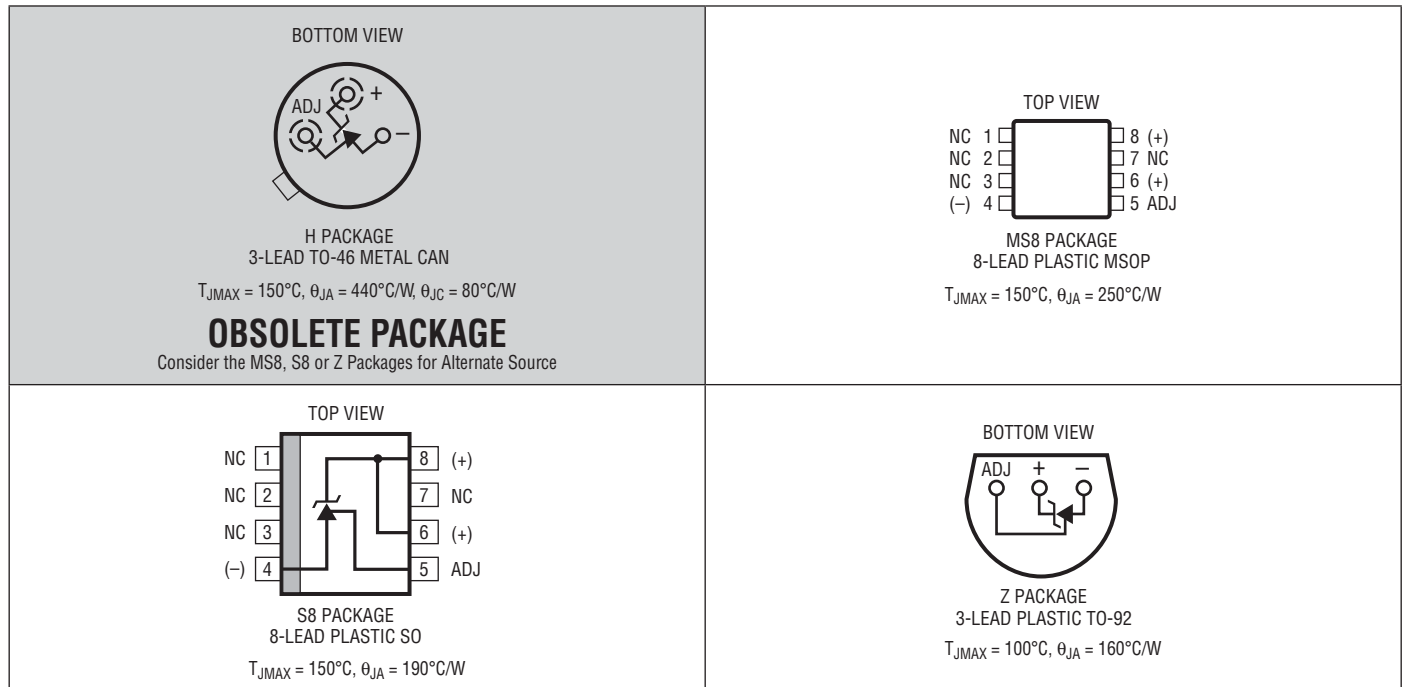

ORDER INFORMATION

| LEAD FREE FINISH | TAPE AND REEL | PART MARKING | PACKAGE DESCRIPTION | TEMPERATURE RANGE |
|------------------|------------------|--------------|------------------------|-------------------|
| LT1009MH#PBF | LT1009MH#TRPBF | | 3-Lead TO-46 Metal Can | -55°C to 125°C |
| LT1009CH#PBF | LT1009CH#TRPBF | | 3-Lead TO-46 Metal Can | 0°C to 70°C |
| LT1009CMS8#PBF | LT1009CMS8#TRPBF | LTQZ | 8-Lead Plastic MSOP | 0°C to 70°C |
| LT1009S8#PBF | LT1009S8#TRPBF | 1009 | 8-Lead Plastic SO | 0°C to 70°C |
| LT1009IS8#PBF | LT1009IS8#TRPBF | 1009I | 8-Lead Plastic SO | -40°C to 85°C |
| LT1009CZ#PBF | LT1009CZ#TRPBF | | 3-Lead Plastic TO-92 | 0°C to 70°C |
| LT1009IZ#PBF | LT1009IZ#TRPBF | | 3-Lead Plastic TO-92 | -40°C to 85°C |

ORDER INFORMATION

| LEAD BASED FINISH | TAPE AND REEL | PART MARKING | PACKAGE DESCRIPTION | TEMPERATURE RANGE |
|-------------------|---------------|--------------|------------------------|-------------------|
| LT1009MH | LT1009MH#TR | | 3-Lead TO-46 Metal Can | -55°C to 125°C |
| LT1009CH | LT1009CH#TR | | 3-Lead TO-46 Metal Can | 0°C to 70°C |
| LT1009CMS8 | LT1009CMS8#TR | LTQZ | 8-Lead Plastic MSOP | 0°C to 70°C |
| LT1009S8 | LT1009S8#TR | 1009 | 8-Lead Plastic SO | 0°C to 70°C |
| LT1009IS8 | LT1009IS8#TR | 1009I | 8-Lead Plastic SO | -40°C to 85°C |
| LT1009CZ | LT1009CZ#TR | | 3-Lead Plastic TO-92 | 0°C to 70°C |
| LT1009IZ | LT1009IZ#TR | | 3-Lead Plastic TO-92 | -40°C to 85°C |

Consult LTC Marketing for parts specified with wider operating temperature ranges.

For more information on lead free part marking, go to: <http://www.linear.com/leadfree/>

For more information on tape and reel specifications, go to: <http://www.linear.com/tapeandreel/>

AVAILABLE OPTIONS

| TEMPERATURE | ACCURACY (%) | TEMPERATURE COEFFICIENT (ppm/°C) | PACKAGE STYLE | | | |
|----------------|--------------|----------------------------------|--------------------|--------------|-----------|-----------|
| | | | TO-46 (H) OBSOLETE | MSOP-8 (MS8) | SO-8 (S8) | TO-92 (Z) |
| 0°C to 70°C | 0.20 | 25 | LT1009CH | LT1009CMS8 | LT1009S8 | LT1009CZ |
| | 0.40 | 25 | | | | |
| -40°C to 85°C | 0.20 | 35 | | | LT1009IS8 | LT1009IZ |
| | 0.40 | 35 | | | | |
| -55°C to 125°C | 0.20 | 35 | LT1009MH | | | |

ELECTRICAL CHARACTERISTICS

The ● denotes the specifications which apply over the full operating temperature range, otherwise specifications are at $T_A = 25^\circ\text{C}$.

| SYMBOL | PARAMETER | CONDITIONS | LT100M | | | LT1009I | | | LT1009/LT1009C | | | UNITS |
|---|--|---|--------|------------|------------|---------|------------|------------|----------------|------------|------------|----------------------------|
| | | | MIN | TYP | MAX | MIN | TYP | MAX | MIN | TYP | MAX | |
| V_Z | Reverse Breakdown Voltage | $T_A = 25^\circ\text{C}$, $I_R = 1\text{mA}$ H, Z Pkg MS, S Pkg | 2.495 | 2.500 | 2.505 | 2.495 | 2.500 | 2.505 | 2.495 | 2.500 | 2.505 | V V |
| $\frac{\Delta V_Z}{\Delta I_R}$ | Reverse Breakdown Change with Current | $400\mu\text{A} \leq I_R \leq 10\text{mA}$ | | 2.6 3.0 | 6 10 | | 2.6 3.0 | 10 12 | | 2.6 3.0 | 10 12 | mV mV |
| r_Z | Reverse Dynamic Impedance | $I_R = 1\text{mA}$ | | 0.2 0.4 | 0.6 1.0 | | 0.2 0.4 | 1.0 1.4 | | 0.2 0.4 | 1.0 1.4 | Ω Ω |
| | Temperature Stability | $T_{\text{MIN}} \leq T_A \leq T_{\text{MAX}}$ | | | 15 | | | 15 | | 1.8 | 4 | mV |
| $\frac{\Delta V_Z}{\Delta \text{Temp}}$ | Average Temperature Coefficient (Notes 2, 3) | $0^\circ\text{C} \leq T_A \leq 70^\circ\text{C}$ $-40^\circ\text{C} \leq T_A \leq 85^\circ\text{C}$ $-55^\circ\text{C} \leq T_A \leq 125^\circ\text{C}$ | | 15 | 25 | | 15 | 25 35 | | 15 | 25 | ppm/°C ppm/°C ppm/°C |
| $\frac{\Delta V_Z}{\Delta \text{Time}}$ | Long-Term Stability | $T_A = 25^\circ\text{C} \pm 0.1^\circ\text{C}$, $I_R = 1\text{mA}$ | | 20 | | | 20 | | | 20 | | ppm/kHr |

Note 1: Stresses beyond those listed under Absolute Maximum Ratings may cause permanent damage to the device. Exposure to any Absolute Maximum Rating condition for extended periods may affect device reliability and lifetime.

Note 2: Guaranteed by Design.

Note 3: Average temperature coefficient is defined as the total voltage change divided by the specified temperature change.

TYPICAL PERFORMANCE CHARACTERISTICS

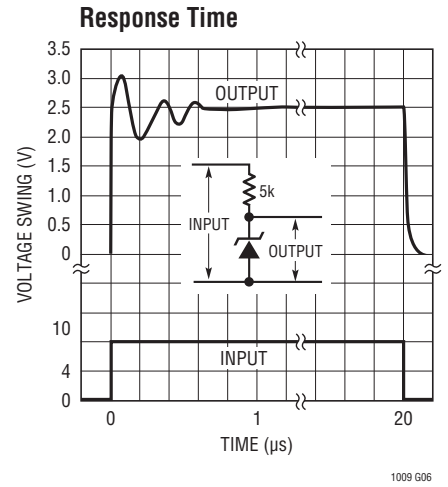
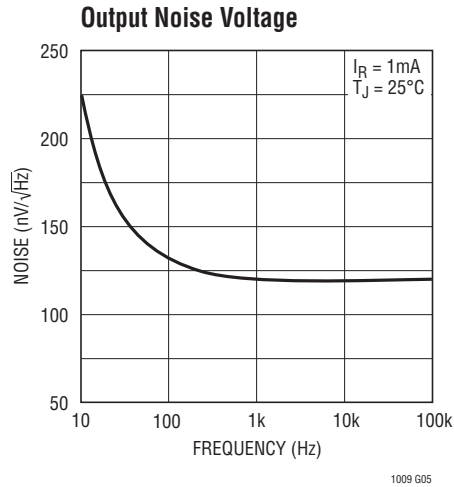
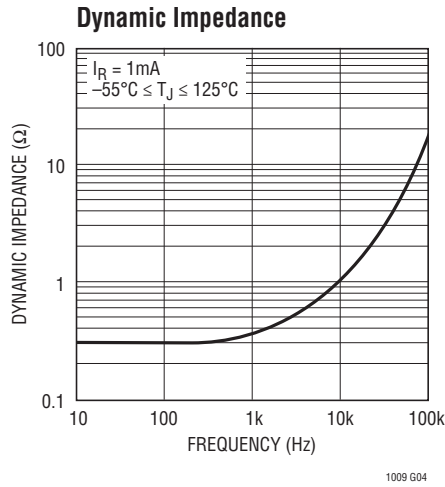
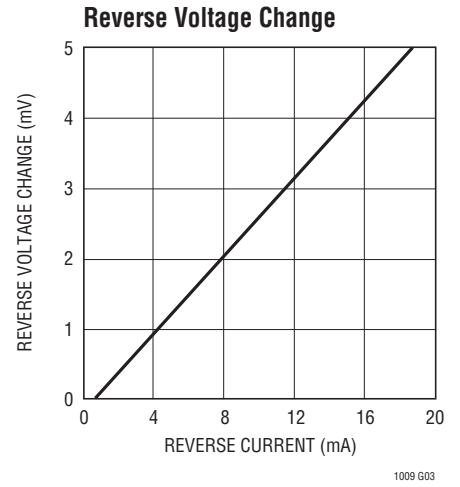
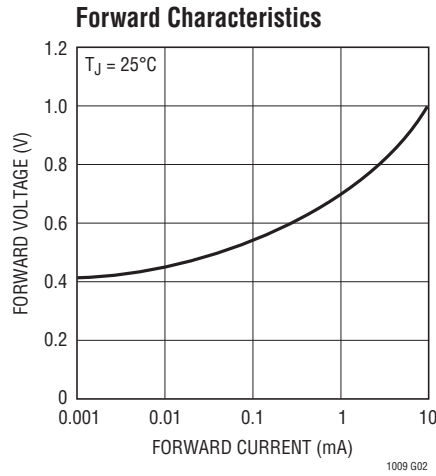
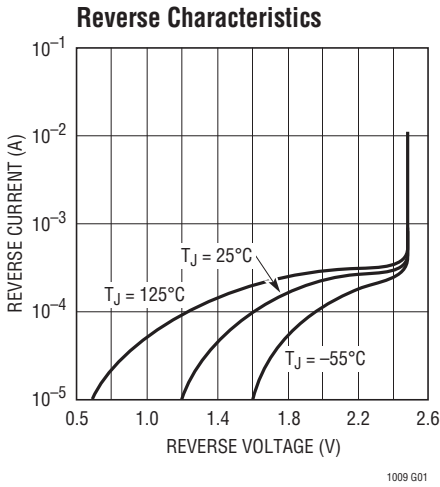

SCHEMATIC DIAGRAM

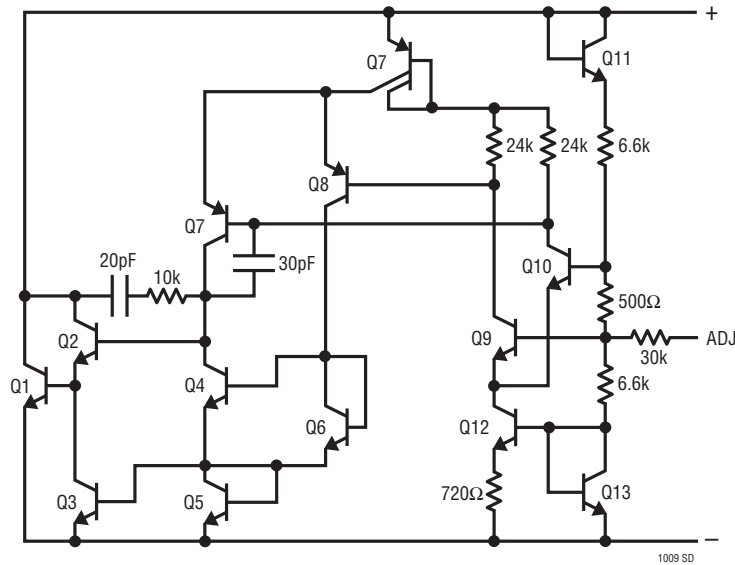

TYPICAL APPLICATIONS

Wide Supply Range, Adjustable Reference

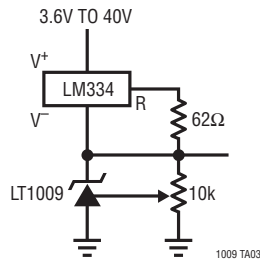

Low Temperature Coefficient Power Regulator

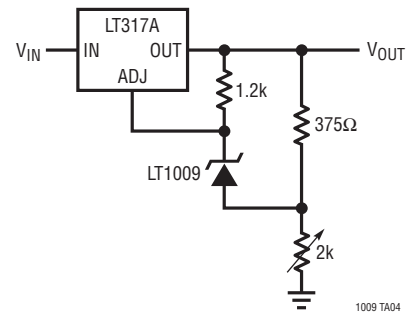

Switchable $\pm 1.25V$ Bipolar Reference

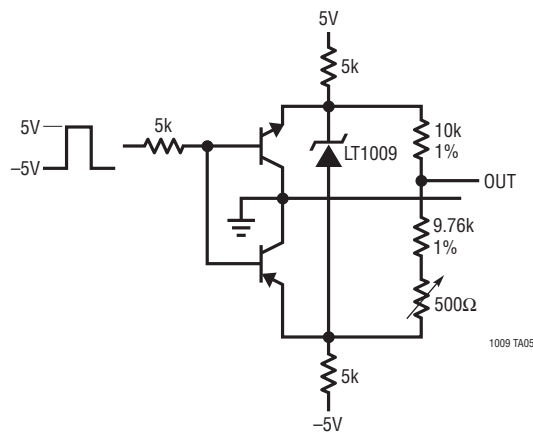

PACKAGE DESCRIPTION

H Package 2-Lead and 3-Lead TO-46 Metal Can (Reference LTC DWG # 05-08-1340)

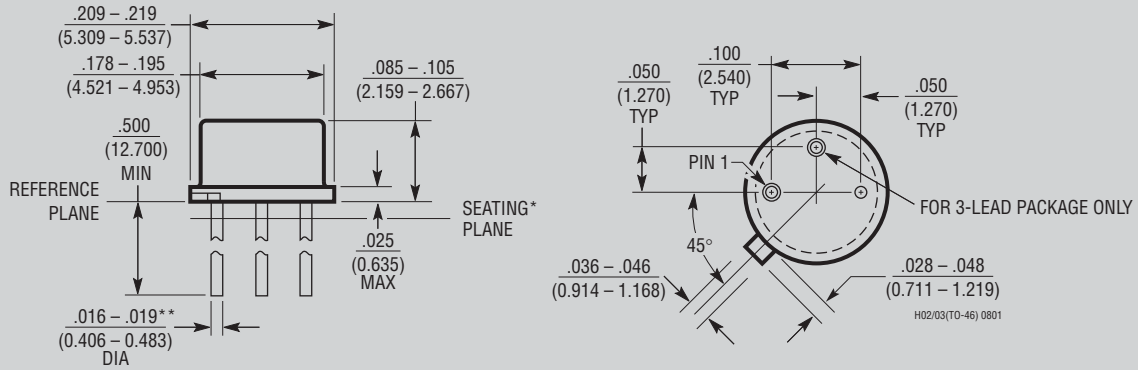

* LEAD DIAMETER IS UNCONTROLLED BETWEEN THE REFERENCE PLANE AND $.050^\circ$ BELOW THE REFERENCE PLANE

** FOR SOLDER DIP LEAD FINISH, LEAD DIAMETER IS $\frac{.016 - .024}{(0.406 - 0.610)}$

OBSOLETE PACKAGE

MS8 Package 8-Lead Plastic MSOP (Reference LTC DWG # 05-08-1660)

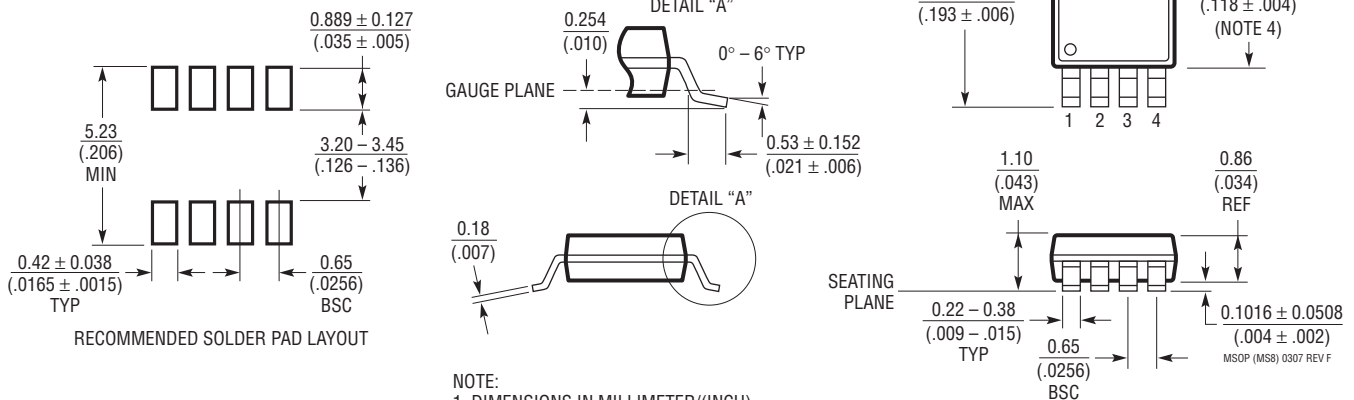

- NOTE:
1. DIMENSIONS IN MILLIMETER/(INCH)
 2. DRAWING NOT TO SCALE
 3. DIMENSION DOES NOT INCLUDE MOLD FLASH, PROTRUSIONS OR GATE BURRS. MOLD FLASH, PROTRUSIONS OR GATE BURRS SHALL NOT EXCEED 0.152mm (.006") PER SIDE
 4. DIMENSION DOES NOT INCLUDE INTERLEAD FLASH OR PROTRUSIONS. INTERLEAD FLASH OR PROTRUSIONS SHALL NOT EXCEED 0.152mm (.006") PER SIDE
 5. LEAD COPLANARITY (BOTTOM OF LEADS AFTER FORMING) SHALL BE 0.102mm (.004") MAX

PACKAGE DESCRIPTION

S8 Package 8-Lead Plastic Small Outline (Narrow .150 Inch) (Reference LTC DWG # 05-08-1610)

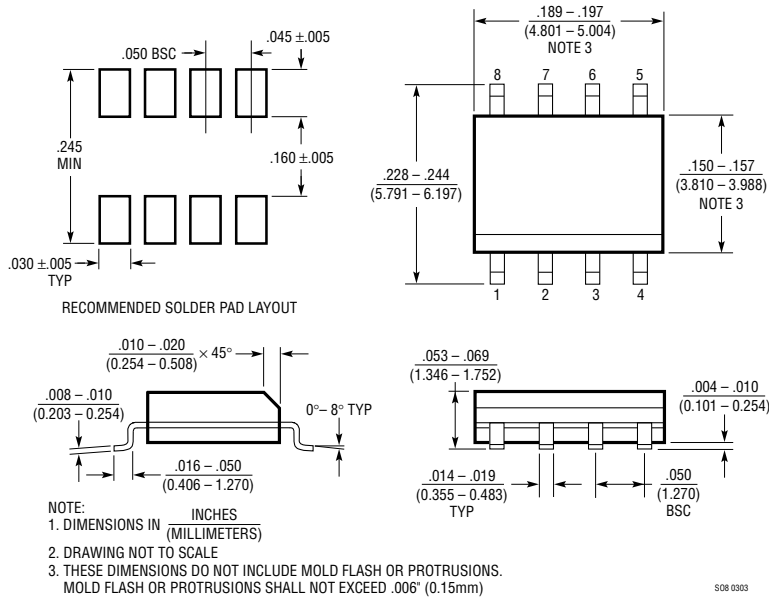

Z Package 3-Lead Plastic TO-92 (Similar to TO-226) (Reference LTC DWG # 05-08-1410)

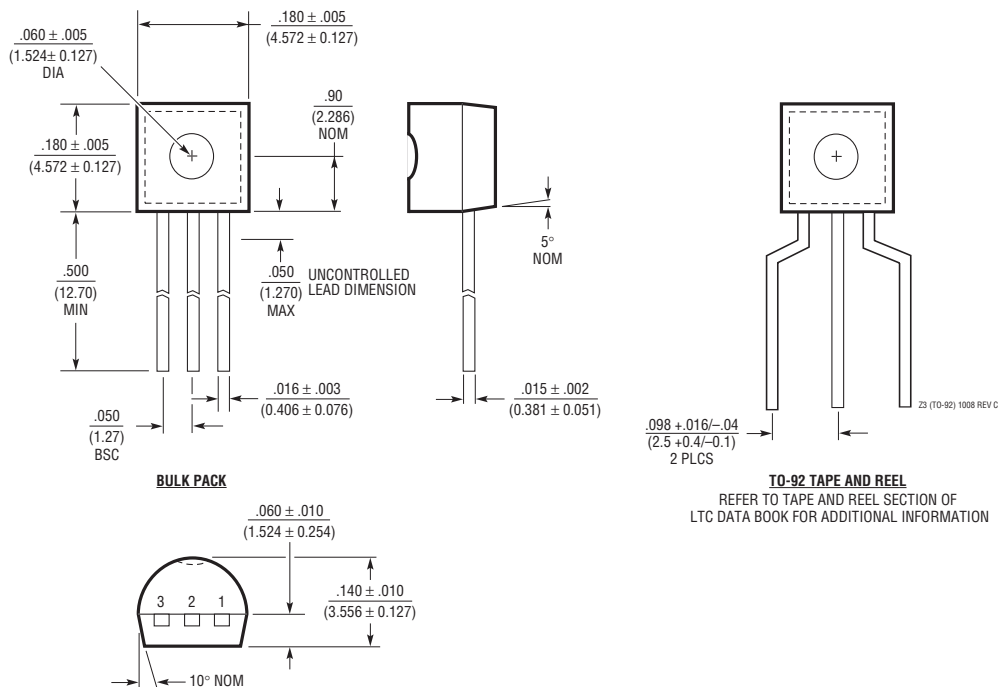

TYPICAL APPLICATION

Low Noise 2.5V Buffered Reference

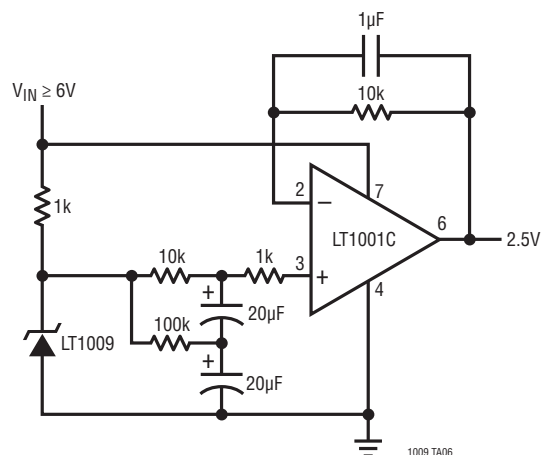

RELATED PARTS

| PART NUMBER | DESCRIPTION | COMMENTS |
|-------------|--|---|
| LT1019 | Precision Series Reference | Bandgap, 0.05%, 5ppm/°C |
| LT1236 | Precision Series Reference | 5V and 10V Zener-Based 5ppm/°C, SO-8 Package |
| LTC®1798 | Micropower Low Dropout Series Reference | 0.15% Max, 6.5µA Supply Current |
| LT1460 | Micropower Precision Series Reference | Bandgap, 130µA Supply Current 10ppm/°C, Available in SOT-23 |
| LT1634 | Micropower Precision Shunt Voltage Reference | Bandgap 0.05%, 10ppm/°C, 10µA Supply Current |
| LT1461 | Micropower Precision Series Reference | 0.04% Max, 3ppm/°C Max, 35µA Supply Current |