

# Dual Precision Instrumentation Switched Capacitor Building Block

## FEATURES

- Instrumentation Front End with 120dB CMRR
- Precise, Charge-Balanced Switching
- Operates from 3V to 18V
- Internal or External Clock
- Operates up to 5MHz Clock Rate
- Low Power
- Two Independent Sections with One Clock

## APPLICATIONS

- Precision Instrumentation Amplifiers
- Ultra Precision Voltage Inverters, Multipliers and Dividers
- V–F and F–V Converters
- Sample-and-Hold
- Switched Capacitor Filters

## DESCRIPTION

The LTC<sup>®</sup>1043 is a monolithic, charge-balanced, dual switched capacitor instrumentation building block. A pair of switches alternately connects an external capacitor to an input voltage and then connects the charged capacitor across an output port. The internal switches have a break-before-make action. An internal clock is provided and its frequency can be adjusted with an external capacitor. The LTC1043 can also be driven with an external CMOS clock.

The LTC1043, when used with low clock frequencies, provides ultra precision DC functions without requiring precise external components. Such functions are differential voltage to single-ended conversion, voltage inversion, voltage multiplication and division by 2, 3, 4, 5, etc. The LTC1043 can also be used for precise V–F and F–V circuits without trimming, and it is also a building block for switched capacitor filters, oscillators and modulators.

The LTC1043 is manufactured using Linear Technology’s enhanced LTCMOS<sup>™</sup> silicon gate process.

**LT**, LTC and LT are registered trademarks of Linear Technology Corporation. LTCMOS is a trademark of Linear Technology Corporation.

## TYPICAL APPLICATION

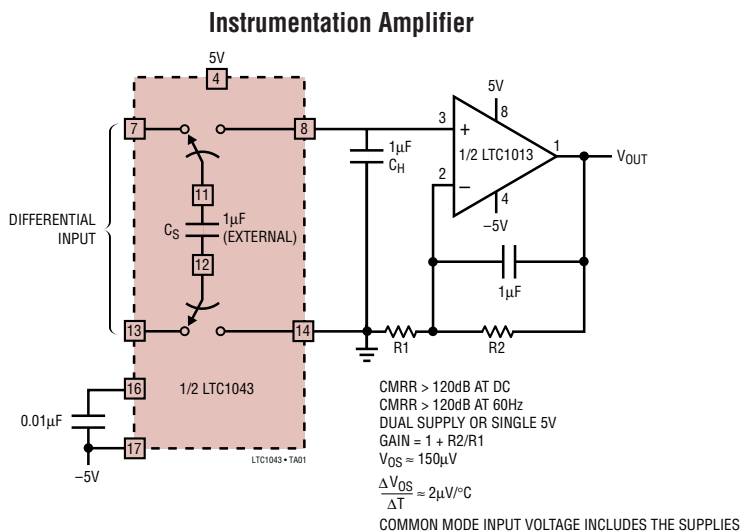

**CMRR vs Frequency**

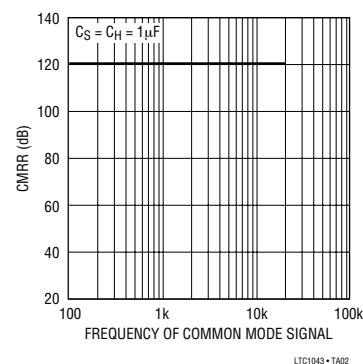

## ABSOLUTE MAXIMUM RATINGS

(Note 1)

Supply Voltage .....	18V
Input Voltage at Any Pin .....	$-0.3V \leq V_{IN} \leq V^+ + 0.3V$
Operating Temperature Range	
LTC1043C .....	$-40^{\circ}\text{C} \leq T_A \leq 85^{\circ}\text{C}$
LTC1043M (OBSOLETE).....	$-55^{\circ}\text{C} \leq T_A \leq 125^{\circ}\text{C}$
Storage Temperature Range .....	$-65^{\circ}\text{C}$ to $150^{\circ}\text{C}$
Lead Temperature (Soldering, 10 sec).....	$300^{\circ}\text{C}$

## PACKAGE/ORDER INFORMATION

<p>TOP VIEW</p> <p>N PACKAGE 18-LEAD PDIP</p> <p>SW PACKAGE 18-LEAD PLASTIC SO</p> <p><math>T_{JMAX} = 100^{\circ}\text{C}</math>, <math>\theta_{JA} = 100^{\circ}\text{C/W}</math> PACKAGE (N)  <math>T_{JMAX} = 150^{\circ}\text{C}</math>, <math>\theta_{JA} = 85^{\circ}\text{C/W}</math> PACKAGE (SW)</p> <p>D PACKAGE 18-LEAD SIDE BRAZED (HERMETIC)</p> <p><b>OBSOLETE PACKAGE</b> Consider the N18 Package as an Alternate Source</p>	ORDER PART NUMBER
	LTC1043CN LTC1043CSW
	LTC1043MD

Consult LTC Marketing for parts specified with wider operating temperature ranges.

## ELECTRICAL CHARACTERISTICS

The ● denotes specifications which apply over the full operating temperature range, otherwise specifications are at  $T_A = 25^{\circ}\text{C}$ .  $V^+ = 10\text{V}$ ,  $V^- = 0\text{V}$ , LTC1043M operates from  $-55^{\circ}\text{C} \leq T_A \leq 125^{\circ}\text{C}$ ; LTC1043C operates from  $-40^{\circ}\text{C} \leq T_A \leq 85^{\circ}\text{C}$ , unless otherwise noted.

SYMBOL	PARAMETER	CONDITIONS	LTC1043M			LTC1043C			UNITS	
			MIN	TYP	MAX	MIN	TYP	MAX		
$I_S$	Power Supply Current	Pin 16 Connected High or Low	●	0.25	0.4	0.7	0.25	0.4	0.7	mA
		$C_{OSC}$ (Pin 16 to $V^-$ ) = 100pF	●	0.4	0.65	1	0.4	0.65	1	mA
$I_I$	OFF Leakage Current	Any Switch, Test Circuit 1 (Note 2)	●	6	100	500	6	100	500	pA
			●	6	500	1000	6	100	500	nA
$R_{ON}$	ON Resistance	Test Circuit 2, $V_{IN} = 7\text{V}$ , $I = \pm 0.5\text{mA}$ $V^+ = 10\text{V}$ , $V^- = 0\text{V}$	●	240	400	700	240	400	700	$\Omega$
		Test Circuit 2, $V_{IN} = 3.1\text{V}$ , $I = \pm 0.5\text{mA}$ $V^+ = 5\text{V}$ , $V^- = 0\text{V}$	●	400	700	1	400	700	1	$\text{k}\Omega$
$f_{OSC}$	Internal Oscillator Frequency	$C_{OSC}$ (Pin 16 to $V^-$ ) = 0pF	●	185			185			kHz
		$C_{OSC}$ (Pin 16 to $V^-$ ) = 100pF	●	20	34	50	20	34	50	kHz
		Test Circuit 3	●	15		75	15		75	kHz
$I_{OSC}$	Pin Source or Sink Current	Pin 16 at $V^+$ or $V^-$	●	40	70	100	40	70	100	$\mu\text{A}$
			●							$\mu\text{A}$
	Break-Before-Make Time			25		25			ns	
	Clock to Switching Delay	$C_{OSC}$ Pin Externally Driven		75		75			ns	
$f_M$	Max External CLK Frequency	$C_{OSC}$ Pin Externally Driven with CMOS Levels		5		5			MHz	
CMRR	Common Mode Rejection Ratio	$V^+ = 5\text{V}$ , $V^- = -5\text{V}$ , $-5\text{V} < V_{CM} < 5\text{V}$ DC to 400Hz		120		120			dB	

**Note 1:** Absolute Maximum Ratings are those values beyond which the life of a device may be impaired.

**Note 2:** OFF leakage current is guaranteed but not tested at  $25^{\circ}\text{C}$ .

# TYPICAL PERFORMANCE CHARACTERISTICS (Test Circuits 2 through 4)

**Power Supply Current vs Power Supply Voltage**

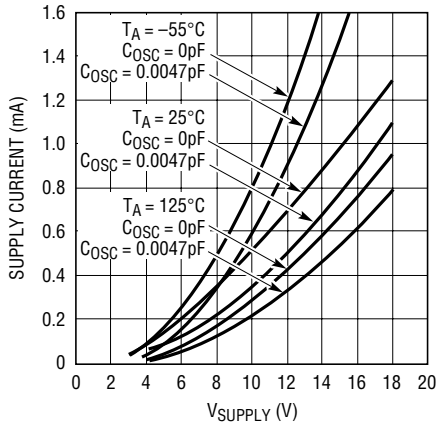

LTC1043 • TPC01

**R<sub>ON</sub> vs V<sub>IN</sub>**

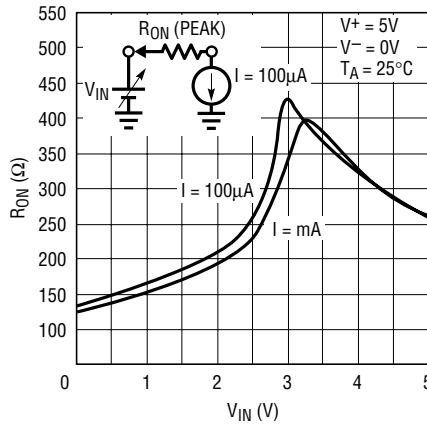

LTC1043 • TPC02

**R<sub>ON</sub> vs V<sub>IN</sub>**

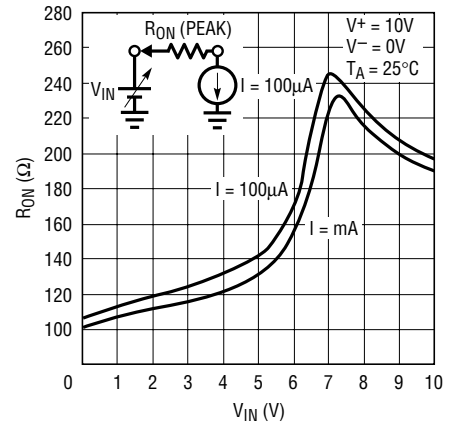

LTC1043 • TPC03

**R<sub>ON</sub> vs V<sub>IN</sub>**

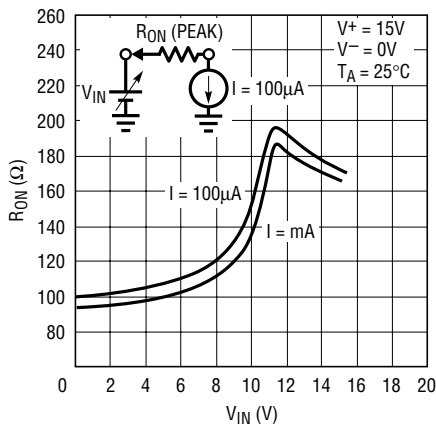

LTC1043 • TPC04

**R<sub>ON</sub> (Peak) vs Power Supply Voltage**

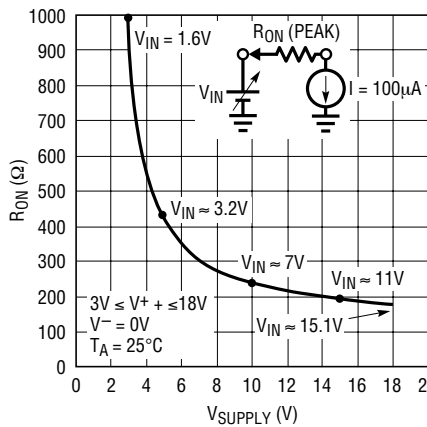

LTC1043 • TPC05

**R<sub>ON</sub> (Peak) vs Power Supply Voltage and Temperature**

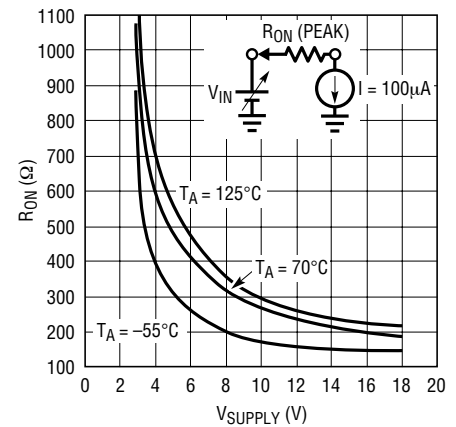

LTC1043 • TPC06

**Oscillator Frequency, f<sub>osc</sub> vs C<sub>osc</sub>**

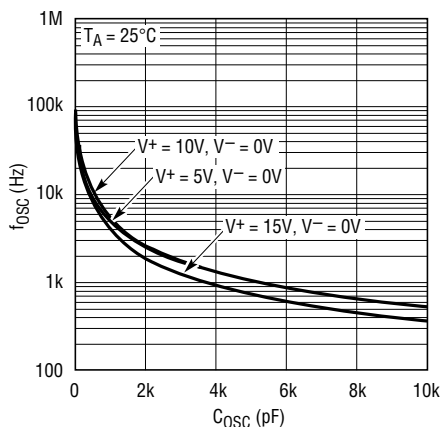

LTC1043 • TPC07

**Oscillator Frequency, f<sub>osc</sub> vs Supply Voltage**

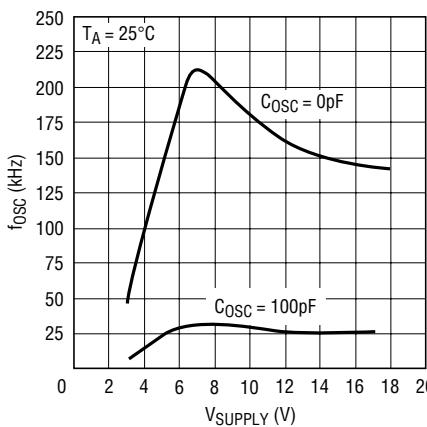

LTC1043 • TPC08

**Normalized Oscillator Frequency, f<sub>osc</sub> vs Supply Voltage**

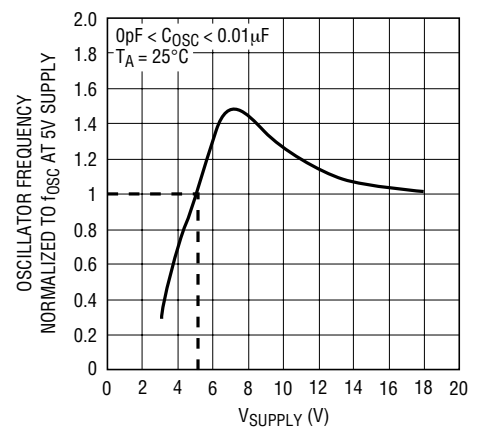

LTC1043 • TPC09

## TYPICAL PERFORMANCE CHARACTERISTICS (Test Circuits 2 through 4)

**Oscillator Frequency,  $f_{osc}$  vs Ambient Temperature,  $T_A$**

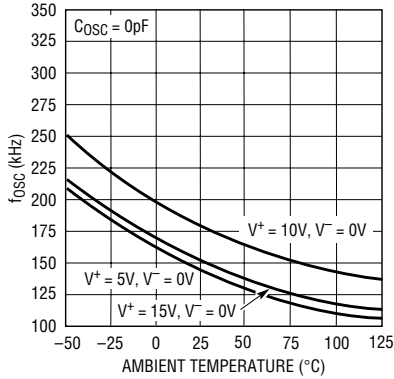

**C<sub>osc</sub> Pin  $I_{SINK}$ ,  $I_{SOURCE}$  vs Supply Voltage**

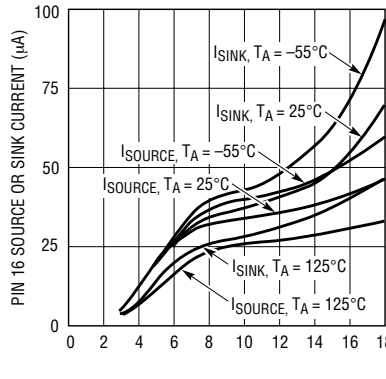

**Break-Before-Make Time,  $t_{NOV}$ , vs Supply Voltage**

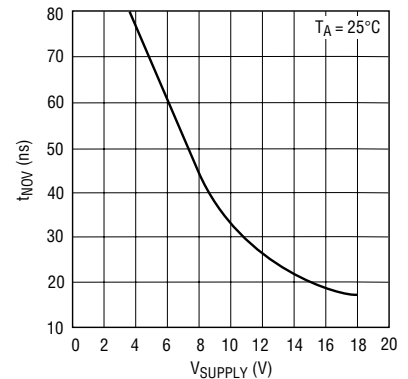

## BLOCK DIAGRAM

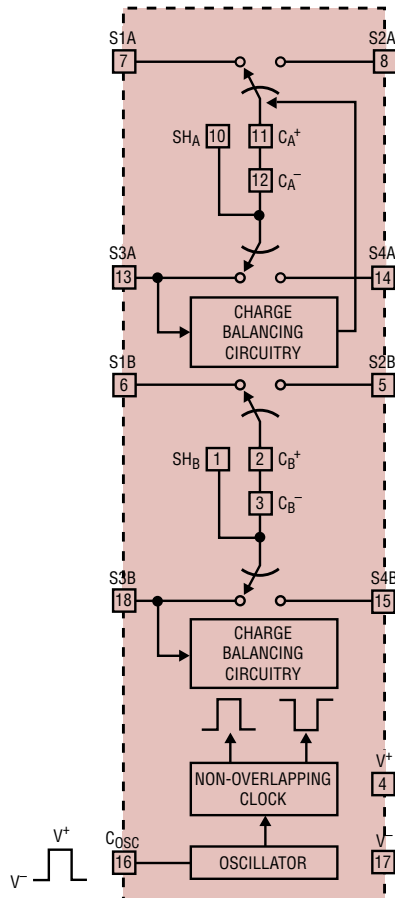

THE SWITCHES ARE TIMED AS SHOWN WITH PIN 16 HIGH

THE CHARGE BALANCING CIRCUITRY SAMPLES THE VOLTAGE AT S3 WITH RESPECT TO S4 (PIN 16 HIGH) AND INJECTS A SMALL CHARGE AT THE C<sup>+</sup> PIN (PIN 16 LOW). THIS BOOSTS THE CMRR WHEN THE LTC1043 IS USED AS AN INSTRUMENTATION AMPLIFIER FRONT END. FOR MINIMUM CHARGE INJECTION IN OTHER TYPES OF APPLICATIONS, S3A AND S3B SHOULD BE GROUND

LTC1043 • BD01

## TEST CIRCUITS

Test Circuit 1. Leakage Current Test

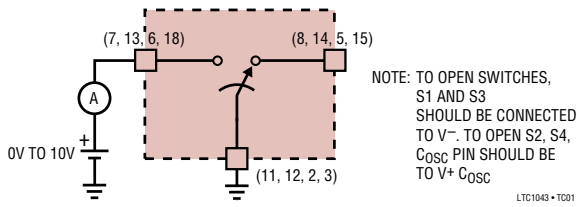

Test Circuit 2.  $R_{ON}$  Test

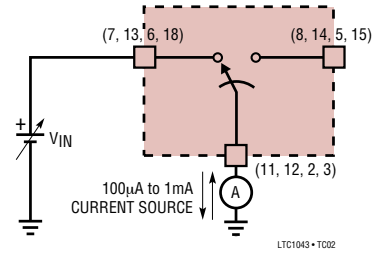

Test Circuit 3. Oscillator Frequency,  $f_{OSC}$

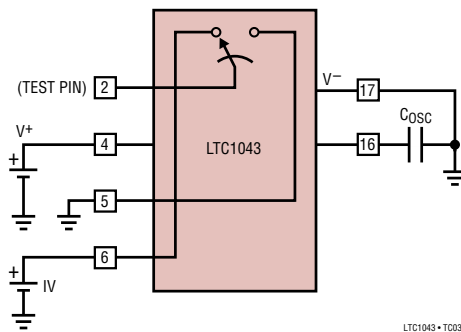

Test Circuit 4. CMRR Test

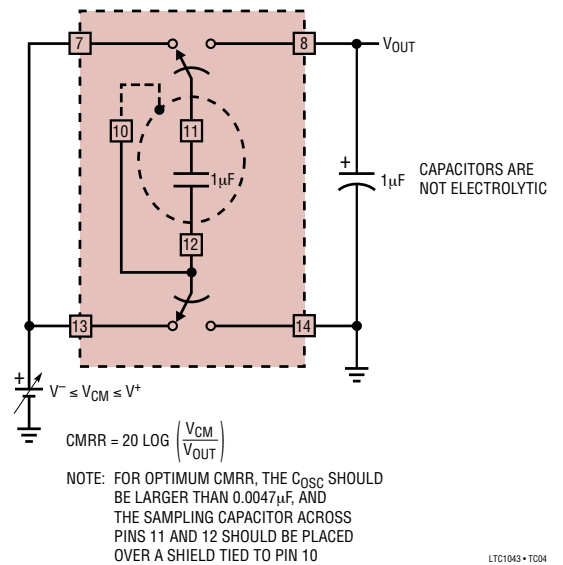

## APPLICATIONS INFORMATION

### Common Mode Rejection Ratio (CMRR)

The LTC1043, when used as a differential to single-ended converter rejects common mode signals and preserves differential voltages (Figure 1). Unlike other techniques, the LTC1043's CMRR does not degrade with increasing common mode voltage frequency. During the sampling mode, the impedance of Pins 2, 3 (and 11, 12) should be reasonably balanced, otherwise, common mode signals will appear differentially. The value of the CMRR depends on the value of the sampling and holding capacitors ( $C_S$ ,  $C_H$ ) and on the sampling frequency. Since the common mode voltages are not sampled, the common mode signal frequency can well exceed the sampling frequency without experiencing aliasing phenomena. The CMRR of Figure 1 is measured by

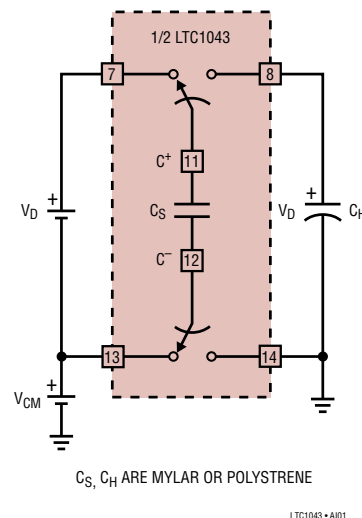

Figure 1. Differential to Single-Ended Converter

## APPLICATIONS INFORMATION

shorting Pins 7 and 13 and by observing, with a precision DVM, the change of the voltage across  $C_H$  with respect to an input CM voltage variation. During the sampling and holding mode, charges are being transferred and minute voltage transients will appear across the holding capacitor. Although the  $R_{ON}$  on the switches is low enough to allow fast settling, as the sampling frequency increases, the rate of charge transfer increases and the average voltage measured with a DVM across it will increase proportionally; this causes the CMRR of the sampled data system, as seen by a “continuous” instrument (DVM), to decrease (Figure 2).

### Switch Charge Injection

Figure 3 shows one out of the eight switches of the LTC1043, configured as a basic sample-and-hold circuit. When the switch opens, a “hold step” is observed and its magnitude depends on the value of the input voltage. Figure 4 shows charge injected into the hold capacitor. For instance, a 2pCb of charge injected into a 0.01 $\mu$ F capacitor causes a 200 $\mu$ V hold step. As shown in Figure 4, there is a predictable and repeatable charge injection cancellation when the input voltage is close to half the supply voltage of the LTC1043. This is a unique feature of this product, containing charge-balanced switches fabricated with a self-aligning gate CMOS process. Any switch of the LTC1043, when powered with symmetrical dual supplies, will sample-and-hold small signals around ground without any significant error.

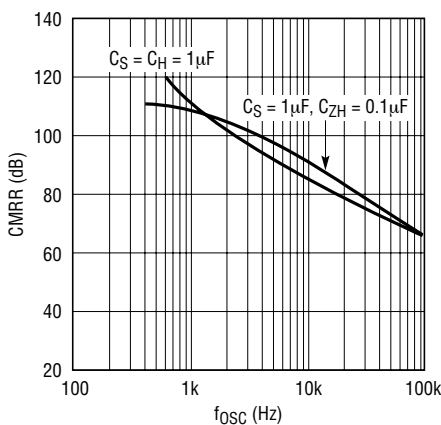

Figure 2. CMRR vs Sampling Frequency

### Shielding the Sampling Capacitor for Very High CMRR

Internal or external parasitic capacitors from the  $C^+$  pin(s) to ground affect the CMRR of the LTC1043 (Figure 1). The common mode error due to the internal junction capacitances of the  $C^+$  Pin(s) 2 and 11 is cancelled through internal circuitry. The  $C^+$  pin, therefore, should be used as the top plate of the sampling capacitor. The interpin capacitance between pin 2 and dummy Pin 1 (11 and 10) appears in parallel with the sampling capacitor so it does not degrade the CMRR. A shield placed underneath the sampling capacitor and connected to either Pin 1 or 3 helps to boost the CMRR in excess of 120dB (Figure 5).

Excessive external parasitic capacitance between the  $C^-$  pins and ground indirectly degrades CMRR; this becomes visible especially when the LTC1043 is used with clock frequencies above 2kHz. Because of this, if a shield is used, the parasitic capacitance between the shield and circuit ground should be minimized.

It is recommended that the outer plate of the sampling capacitor be connected to the  $C^-$  pin(s).

### Input Pins, SCR Sensitivity

An internal 60 $\Omega$  resistor is connected in series with the input of the switches (Pins 5, 6, 7, 8, 13, 14, 15, 18) and it is included in the  $R_{ON}$  specification. When the input voltage exceeds the power supply by a diode drop, current will flow into the input pin(s). The LTC1043 will not latch until the input current reaches 2mA–3mA. The device will

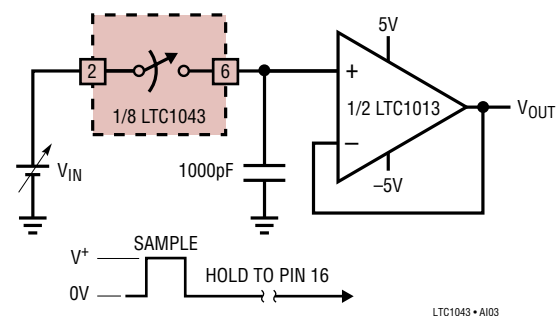

Figure 3

## APPLICATIONS INFORMATION

recover from the latch mode when the input drops 3V to 4V below the voltage value which caused the latch. For instance, if an external resistor of 200Ω is connected in series with an input pin, the input can be taken 1.3V above the supply without latching the IC. The same applies for the C<sup>+</sup> and C<sup>-</sup> pins.

### C<sub>OSC</sub> Pin (16), Figure 6

The C<sub>OSC</sub> pin can be used with an external capacitor, C<sub>OSC</sub>, connected from Pin 16 to Pin 17, to modify the internal oscillator frequency. If Pin 16 is floating, the internal 24pF capacitor, plus any external interpin capacitance, set the oscillator frequency around 190kHz with ±5V supply. The typical performance characteristics curves provide the necessary information to set the oscillator frequency for various power supply ranges. Pin 16 can also be driven

with an external clock to override the internal oscillator. Although standard 7400 series CMOS gates do not guarantee CMOS levels with the current source and sink requirements of Pin 16, they will in reality drive the C<sub>OSC</sub> pin. CMOS gates conforming to standard B series output drive have the appropriate voltage levels and more than enough output current to simultaneously drive several LTC1043 C<sub>OSC</sub> pins. The typical trip levels of the Schmitt trigger (Figure 6) are given below.

SUPPLY	TRIP LEVELS
V <sup>+</sup> = 5V, V <sup>-</sup> = 0V	V <sub>H</sub> = 3.4V V <sub>L</sub> = 1.35V
V <sup>+</sup> = 10V, V <sup>-</sup> = 0V	V <sub>H</sub> = 6.5V V <sub>L</sub> = 2.8V
V <sup>+</sup> = 15V, V <sup>-</sup> = 0V	V <sub>H</sub> = 9.5V V <sub>L</sub> = 4.1V

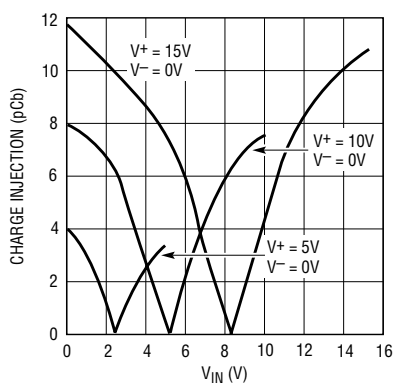

Figure 4. Individual Switch Charge Injection vs Input Voltage

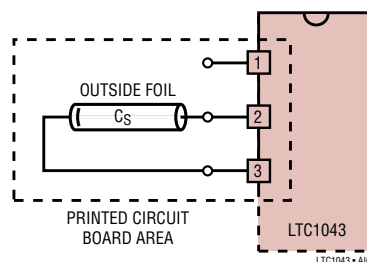
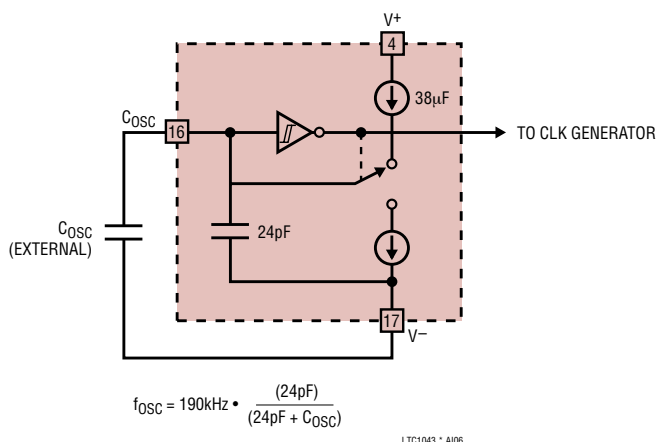

Figure 5. Printed Circuit Board Layout Showing Shielding the Sampling Capacitor



$$f_{OSC} = 190\text{kHz} \cdot \frac{(24\text{pF})}{(24\text{pF} + C_{OSC})}$$

Figure 6. Internal Oscillator

## TYPICAL APPLICATIONS

### Divide by 2

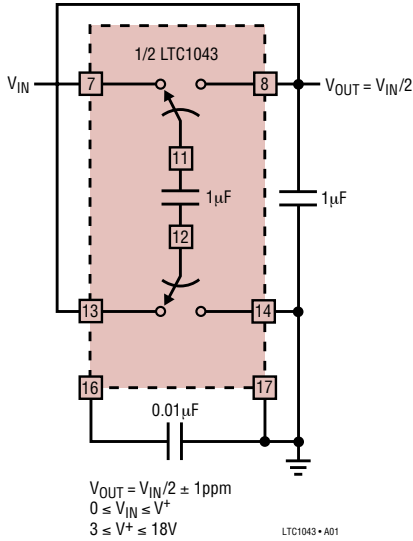

### Multiply by 2

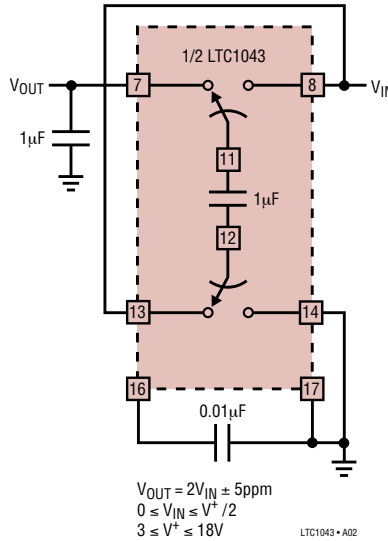

### Ultra Precision Voltage Inverter

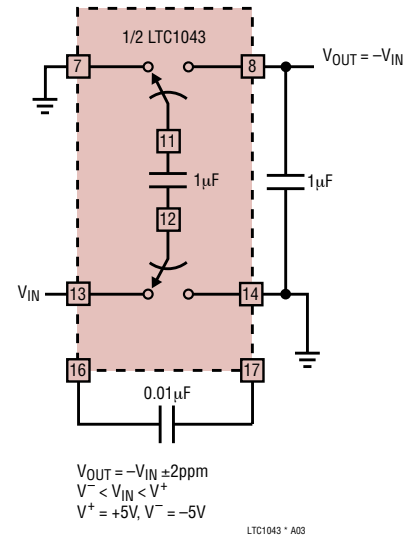

### Precision Multiply by 3

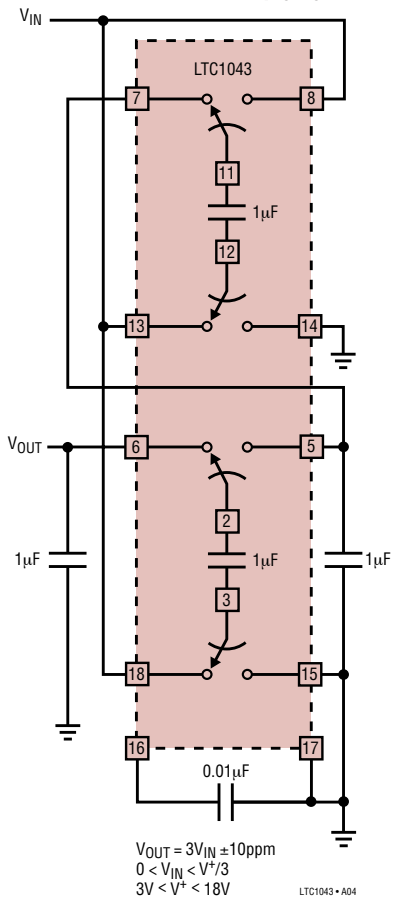

### Precision Multiply by 4

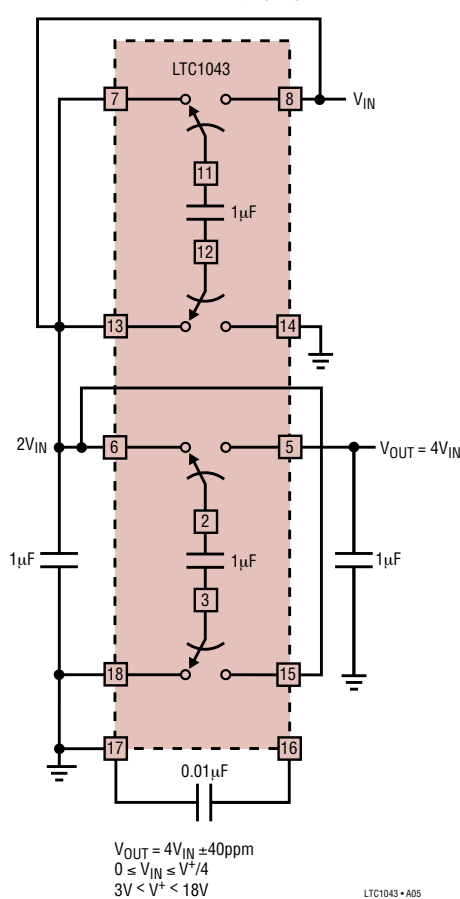

### Divide by 3

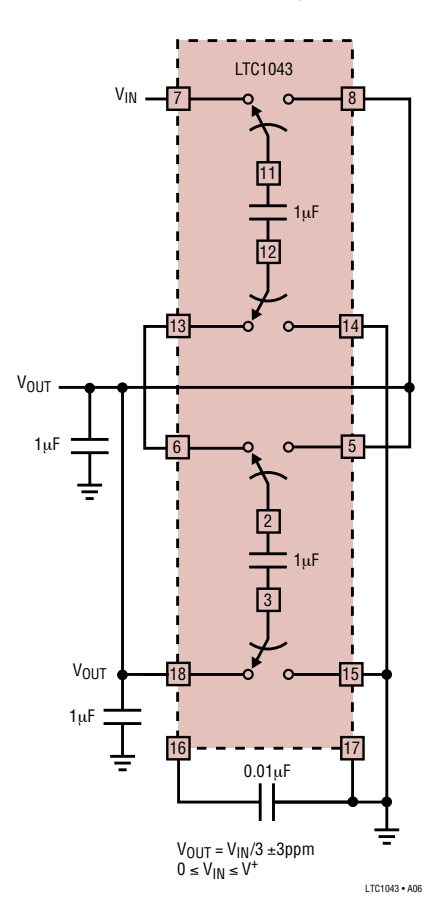

# TYPICAL APPLICATIONS

Divide by 4

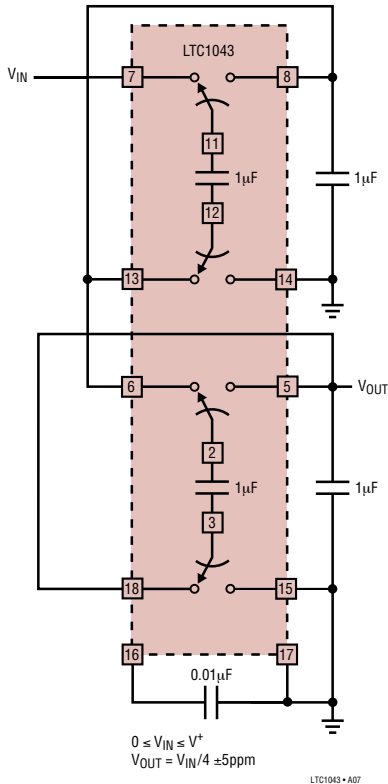

0.005% V/F Converter

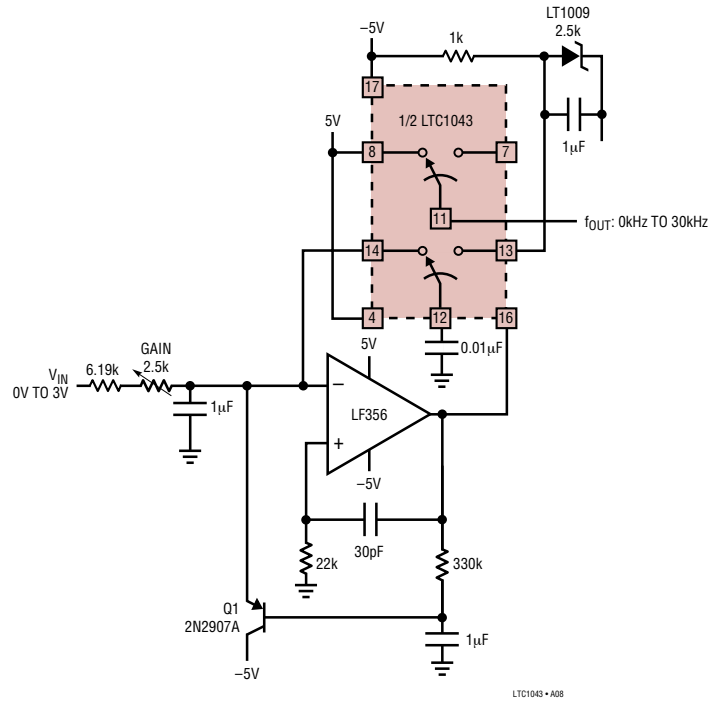

0.01% Analog Multiplier

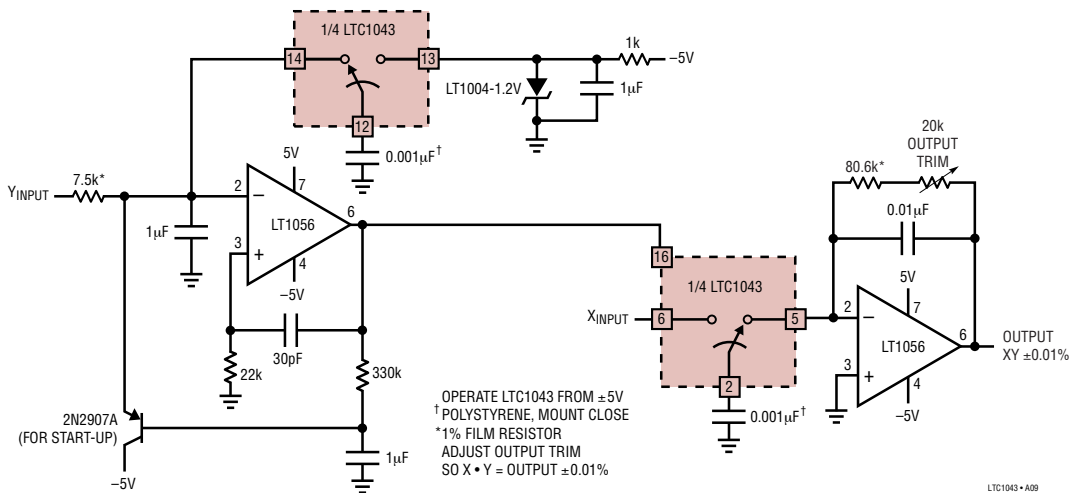

TYPICAL APPLICATIONS

Single 5V Supply, Ultra Precision Instrumentation Amplifier

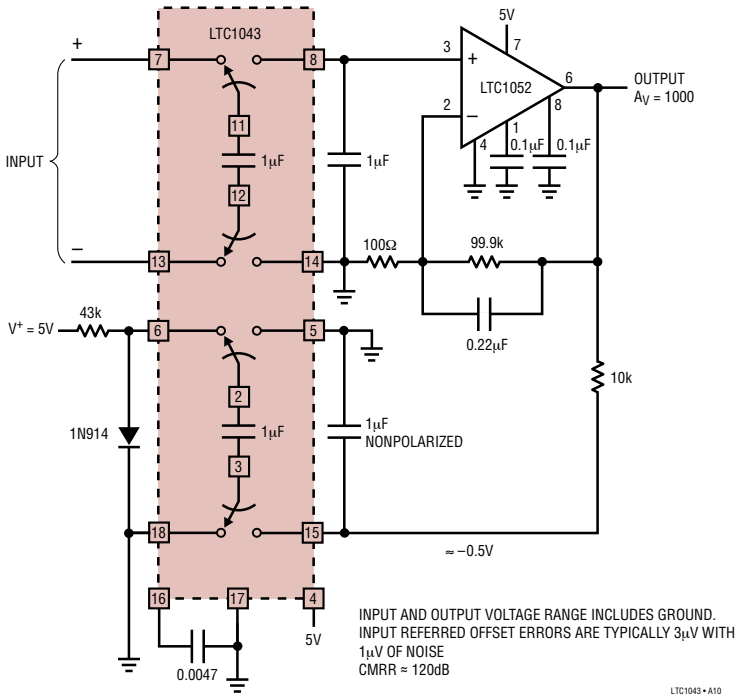

Voltage Controlled Current Source with Ground Referred Input and Output

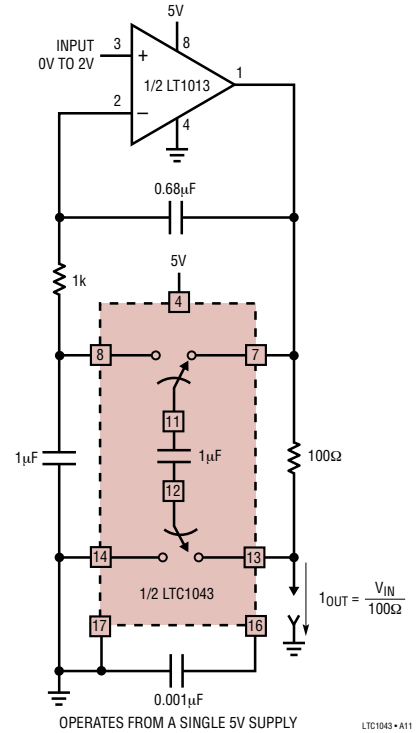

Precision Instrumentation Amplifier

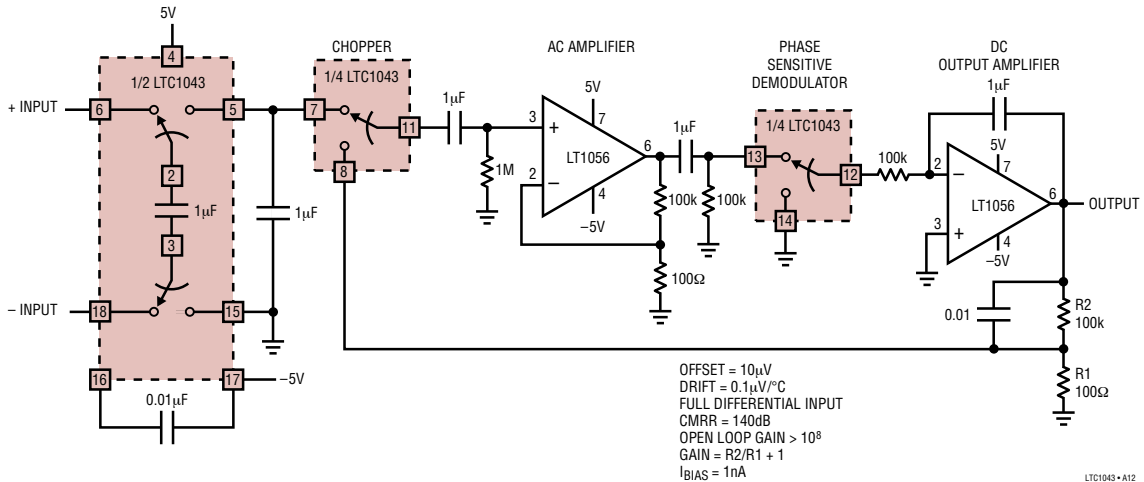

# TYPICAL APPLICATIONS

## Lock-In Amplifier (= Extremely Narrow-Band Amplifier)

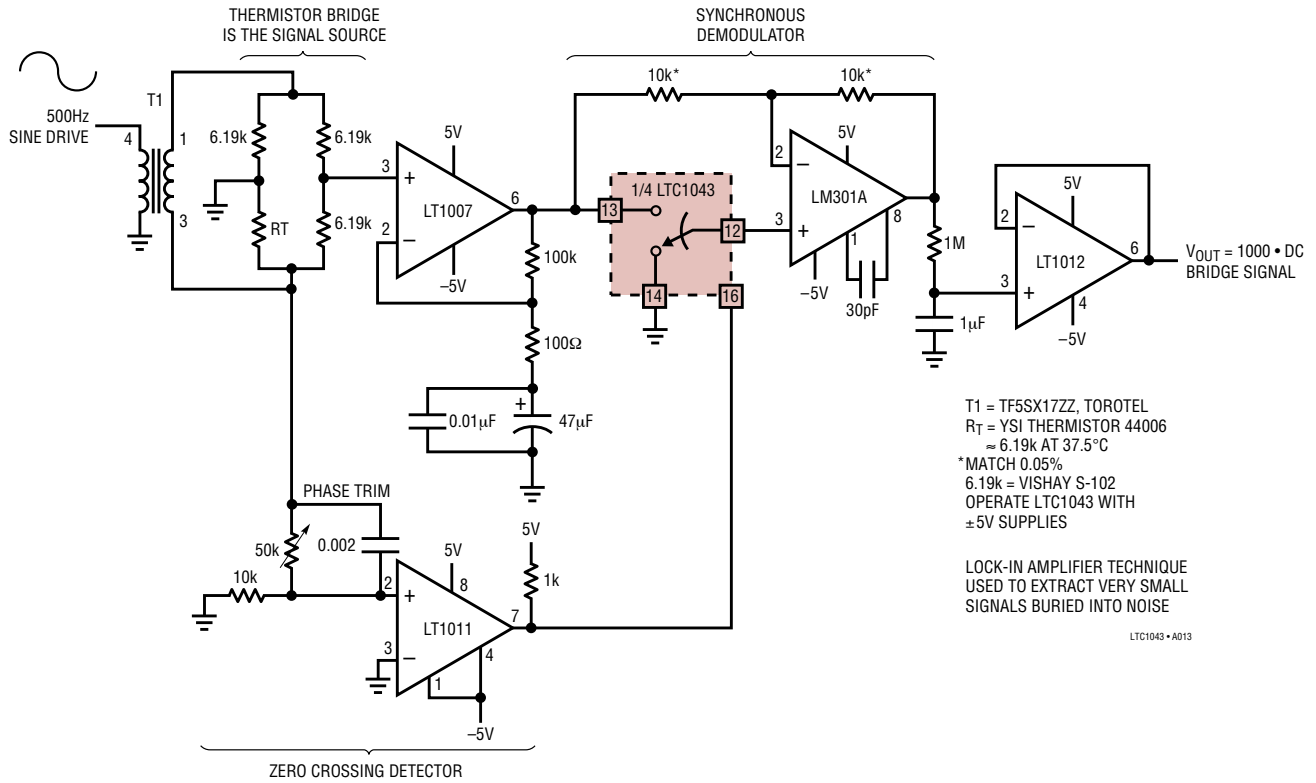

## 50MHz Termal RMS/DC Converter

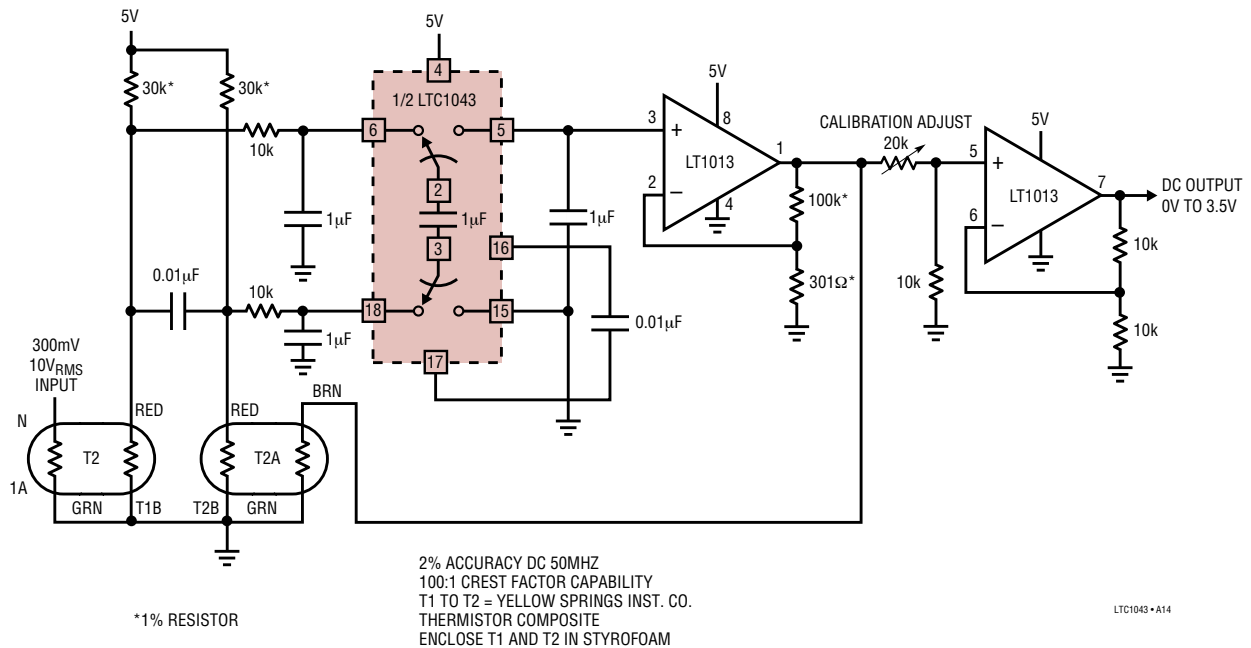



# TYPICAL APPLICATIONS

## 0.005% F/V Converter

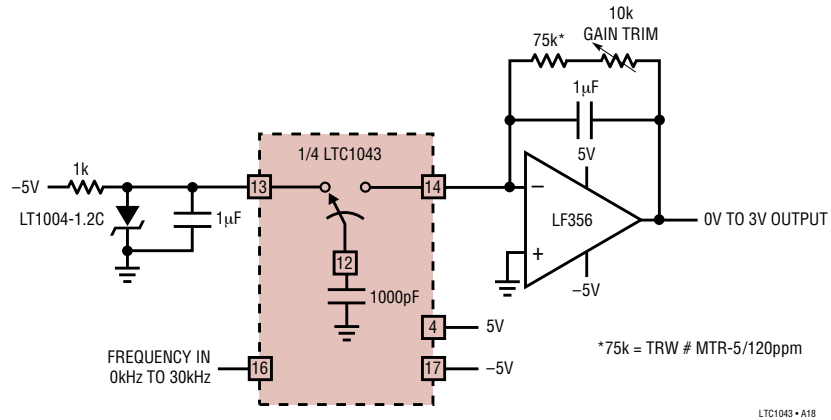

## High Frequency Clock Tunable Bandpass Filter

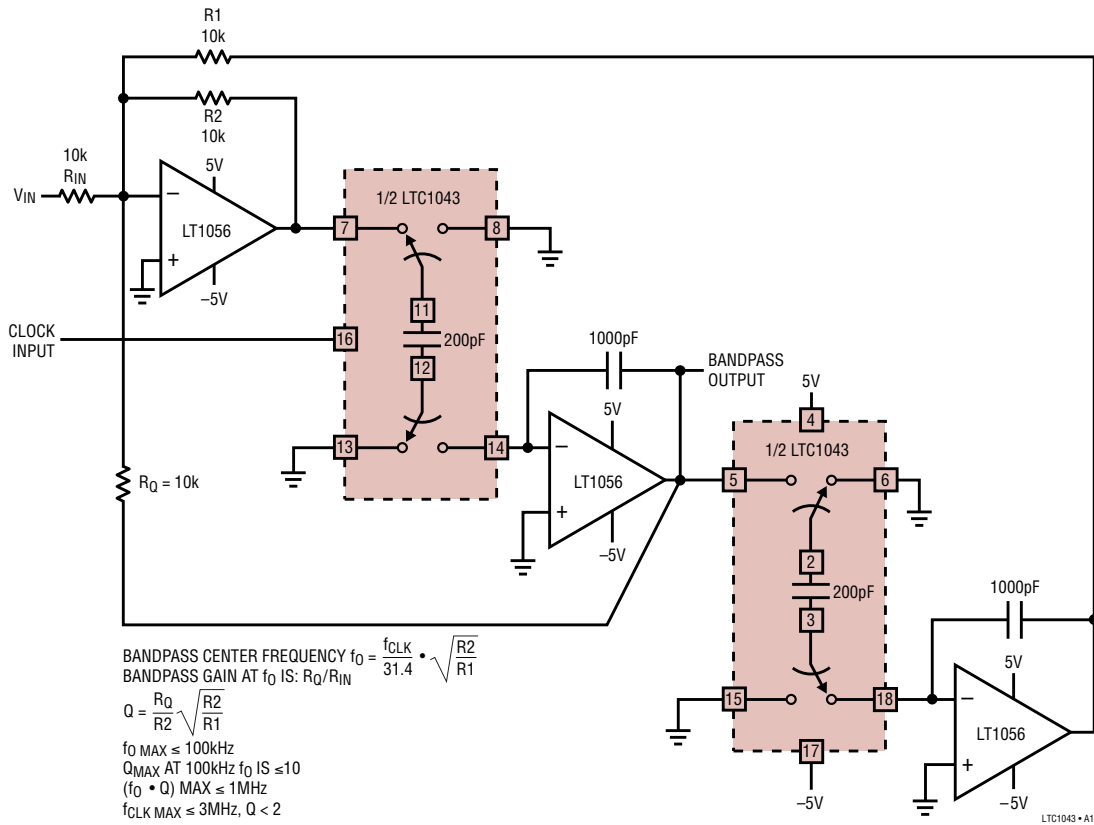

## TYPICAL APPLICATIONS

### Frequency-Controlled Gain Amplifier

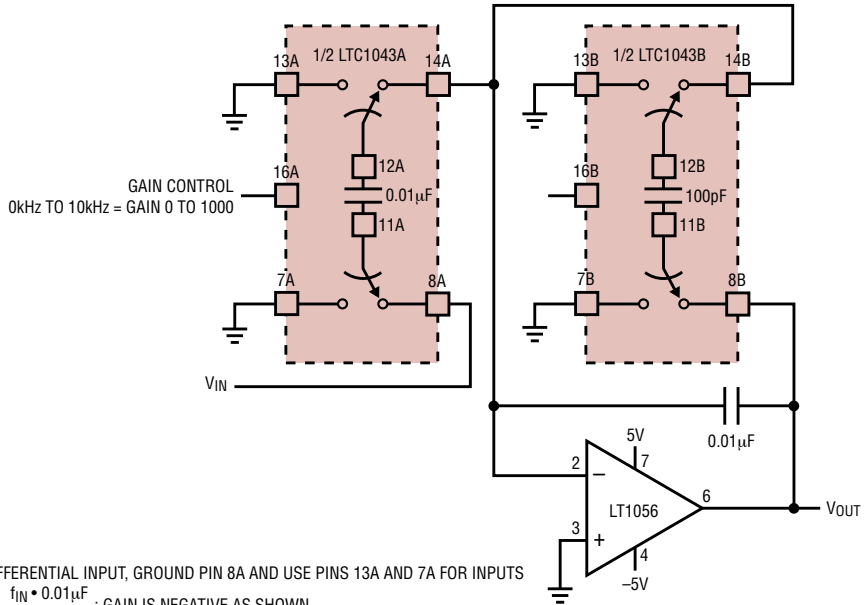

FOR DIFFERENTIAL INPUT, GROUND PIN 8A AND USE PINS 13A AND 7A FOR INPUTS

$$\text{GAIN} = \frac{f_{IN} \cdot 0.01\mu\text{F}}{1\text{kHz} \cdot 100\text{pF}}; \text{GAIN IS NEGATIVE AS SHOWN}$$

FOR SINGLE-ENDED INPUT AND POSITIVE GAIN, GROUND PIN 8A AND USE PIN 7A FOR INPUT  
USE ±5V SUPPLIES FOR LTC1043

LTC1043 • A20

### Relative Humidity Sensor Signal Conditioner

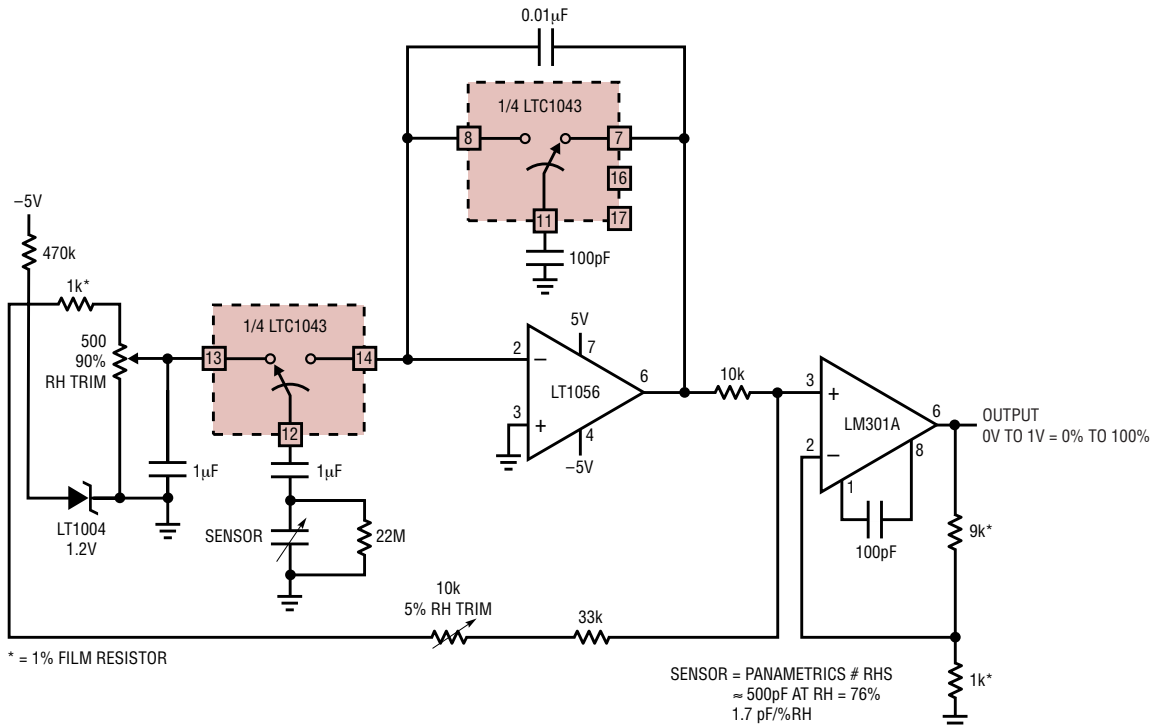

LTC1043 • A21

# TYPICAL APPLICATIONS

## Linear Variable Differential Transformer (LVDT), Signal Conditioner

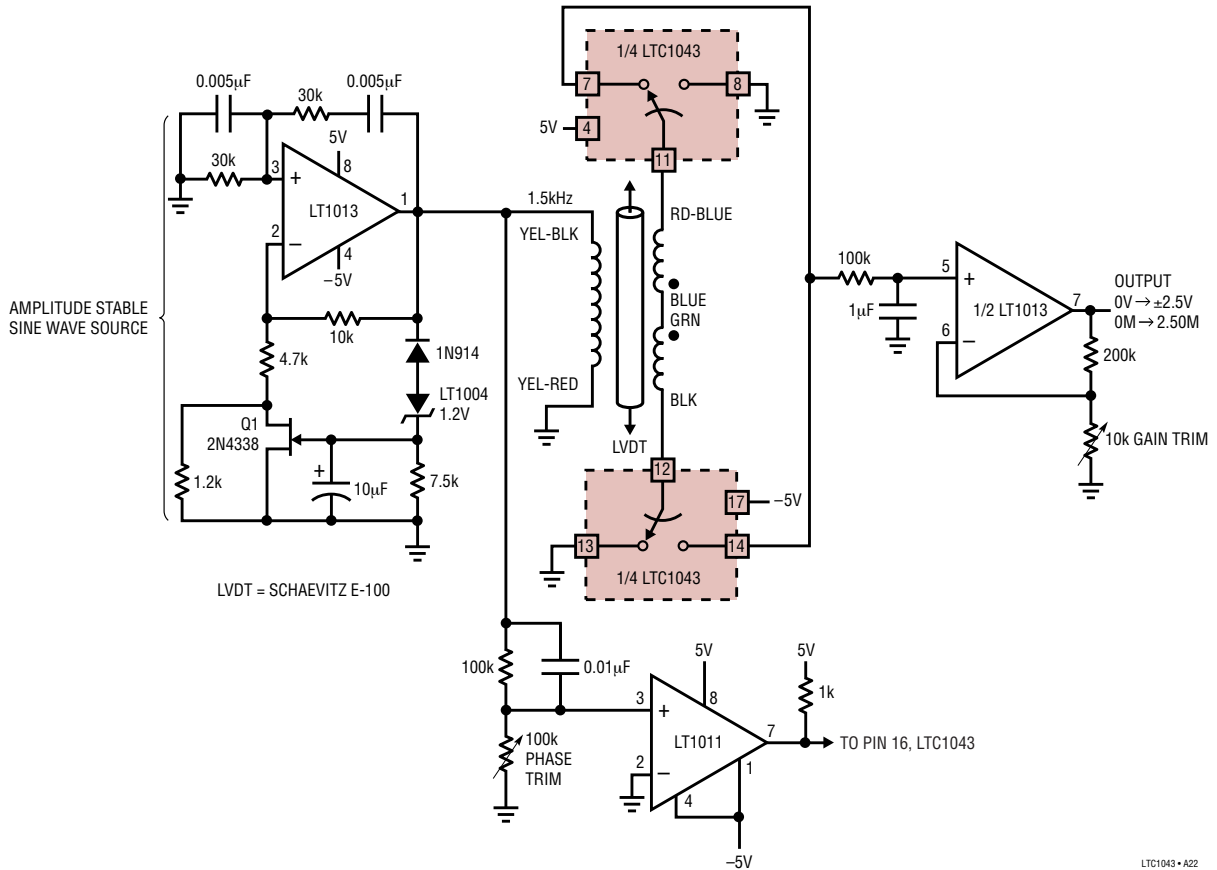

## Precision Current Sensing in Supply Rails

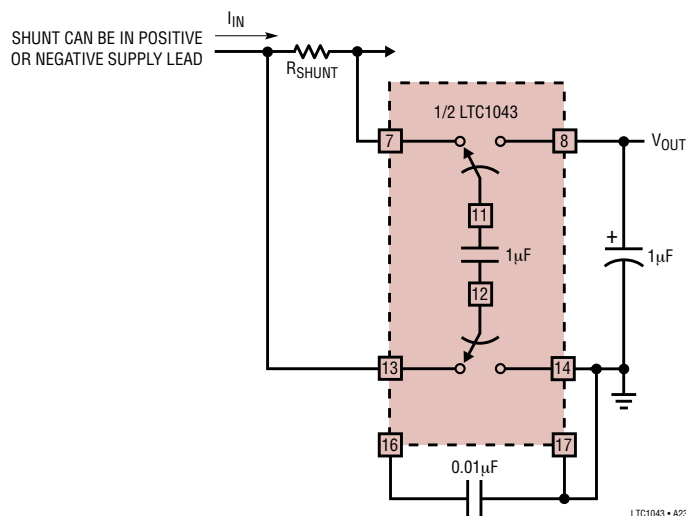

**PACKAGE DESCRIPTION**

