

FEATURES

- *Guaranteed* low offset voltage

LT1002A	60 μ V max
LT1002	100 μ V max
- *Guaranteed* offset voltage match

LT1002A	40 μ V max
LT1002	80 μ V max
- *Guaranteed* low drift

LT1002A	0.9 μ V/ $^{\circ}$ C max
LT1002	1.3 μ V/ $^{\circ}$ C max
- *Guaranteed* CMRR

LT1002A	110dB min
LT1002	110dB min
- *Guaranteed* channel separation

LT1002A	132dB min
LT1002	130dB min
- *Guaranteed* matching characteristics
- Low noise 0.35 μ V_{P-P}

APPLICATIONS

- Thermocouple Amplifiers
- Strain Gauge Amplifiers
- Low level signal processing
- Medical instrumentation
- Precision dual limit threshold detection
- Instrumentation amplifiers

LT, LTC and LT are registered trademarks of Linear Technology Corporation

DESCRIPTION

The LT[®]1002 dual, matched precision operational amplifiers combine excellent individual amplifier performance with tight matching and temperature tracking between amplifiers.

In the design, processing, and testing of the device, particular attention has been paid to the optimization of the entire distribution of several key parameters and their matching. Consequently, the specifications of even the low cost commercial grade (LT1002C) have been spectacularly improved compared to presently available devices.

Essentially, the input offset voltage of all units is less than 80 μ V, and matching between amplifiers is consistently better than 60 μ V (see distribution plot below). Input bias and offset currents, channel separation, common mode and power supply rejections of the LT1002C are all specified at levels which were previously attainable only on very expensive, selected grades of other dual devices. Power dissipation is nearly halved compared to the most popular precision duals, without adversely affecting noise or speed performance. A by-product of lower dissipation is decreased warm-up drift. For even better performance in a single precision op amp, refer to the LT1001 data sheet. A bridge signal conditioning application is shown below. This circuit illustrates the requirement for both excellent matching and individual amplifier specifications.

TYPICAL APPLICATION

Strain Gauge Signal Conditioner with Bridge Excitation

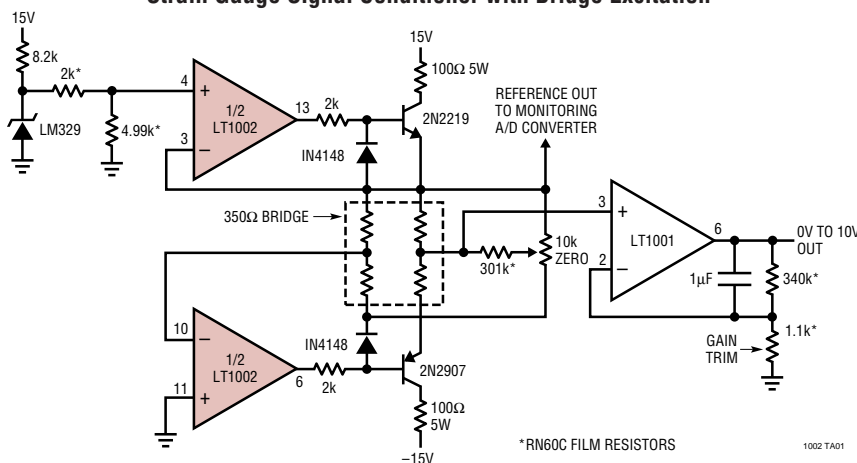

Distribution of Offset Voltage Match

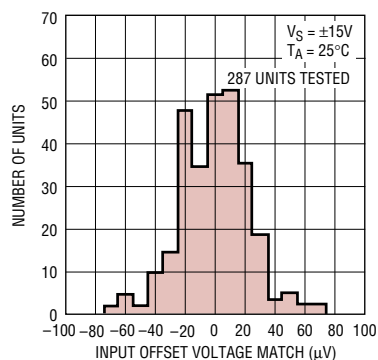

ABSOLUTE MAXIMUM RATINGS

(Note 1)

Supply Voltage (Note 7)	±22V
Differential Input Voltage	±30V
Input Voltage Equal to Supply Voltage	
Output Short Circuit Duration	Indefinite
Operating Temperature Range	
LT1002AM/LT1002M (OBSOLETE)	–55°C to 125°C
LT1002AC/LT1002C	0°C to 70°C
Storage Temperature Range	
All Grades	–65°C to 150°C
Lead Temperature (Soldering, 10 sec.)	300°C

PACKAGE/ORDER INFORMATION

<p>TOP VIEW</p> <p>N PACKAGE 14 PIN PLASTIC T_{JMAX} = 125°C, θ_{JA} = 100°C/W</p> <p>J PACKAGE 14 PIN HERMETIC T_{JMAX} = 125°C, θ_{JA} = 100°C/W</p> <p>NOTE: Device may be operated even if insertion is reversed; this is due to inherent symmetry of pin locations of amplifiers A and B. (Note 7)</p>	ORDER PART NO.	OFFSET VOLTAGE MAX at 25°C
	LT1002ACN LT1002CN	60µV 100µV
	LT1002AMJ LT1002MJ LT1002ACJ LT1002CJ	60µV 100µV 60µV 100µV
OBSOLETE PACKAGE Consider the N Package for Alternate Source		

Consult LTC Marketing for parts specified with wider operating temperature ranges.

ELECTRICAL CHARACTERISTICS, INDIVIDUAL AMPLIFIERS

V_S = ±15V, T_A = 25°C, unless otherwise noted

SYMBOL	PARAMETER	CONDITIONS	LT1002AM/LT1002AC			LT1002M/LT1002C			UNITS
			MIN	TYP	MAX	MIN	TYP	MAX	
V _{OS}	Input Offset Voltage	(Note 2)		20	60		25	100	µV
$\frac{\Delta V_{OS}}{\Delta \text{Time}}$	Long Term Input Offset Voltage Stability	(Notes 3 and 4)		0.3	1.5		0.4	2.0	µV/month
I _{OS}	Input Offset Current			0.3	2.8		0.4	4.2	nA
I _B	Input Bias Current			±0.6	±3.0		±0.7	±4.5	nA
\bar{e}_n	Input Noise Voltage	0.1Hz to 10Hz (Note 3)		0.35	0.7		0.38	0.75	µV _{p-p}
e _n	Input Noise Voltage Density	f ₀ = 10Hz (Note 6) f ₀ = 1000Hz (Note 3)		10.3 9.6	20.0 11.5		10.5 9.8	20.0 12.0	nV√Hz
A _{VOL}	Large Signal Voltage Gain	R _L ≥ 2kΩ, V _O = ±12V R _L ≥ 1kΩ, V _O = ±10V	400 250	800 500		350 220	800 500		V/mV
CMRR	Common Mode Rejection Ratio	V _{CM} = ±13V	110	126		110	126		dB
PSRR	Power Supply Rejection Ratio	V _S = ±3V to ±18V	108	123		105	123		dB
R _{in}	Input Resistance Differential Mode	(Note 5)	20	100		13	80		MΩ
	Input Voltage Range		±13	±14		±13	±14		V
V _{OUT}	Maximum Output Voltage Swing	R _L ≥ 2kΩ R _L ≥ 1kΩ	±13 ±12	±14 ±13.5		±13 ±12	±14 ±13.5		V
SR	Slew Rate	R _L ≥ 2kΩ (Note 5)	0.1	0.25		0.1	0.25		V/µs
GBW	Gain Bandwidth Product	(Note 5)	0.4	0.8		0.4	0.8		MHz
P _d	Power Dissipation per amplifier	No load No load, V _S = ±3V		46 4	75 7		48 4	85 8	mW

ELECTRICAL CHARACTERISTICS, INDIVIDUAL AMPLIFIERS

The ● denotes the specifications which apply over the temperature range $-55^{\circ}\text{C} \leq T_A \leq 125^{\circ}\text{C}$, $V_S = \pm 15\text{V}$, unless otherwise noted.

SYMBOL	PARAMETER	CONDITIONS		LT1002AM			LT1002M			UNITS
				MIN	TYP	MAX	MIN	TYP	MAX	
V_{OS}	Input Offset Voltage	(Note 2)	●		30	150		45	230	μV
$\frac{\Delta V_{OS}}{\Delta \text{Temp}}$	Average Input Offset Voltage Drift		●		0.2	0.9		0.3	1.3	$\mu\text{V}/^{\circ}\text{C}$
I_{OS}	Input Offset Current		●		0.8	5.6		1.2	8.5	nA
I_B	Input Bias Current		●		± 1.0	± 6.0		± 1.5	± 9.0	nA
A_{VOL}	Large Signal Voltage Gain	$R_L \geq 2\text{k}\Omega$, $V_O = \pm 10\text{V}$	●	300	700		200	700		V/mV
CMRR	Common Mode Rejection Ratio	$V_{CM} = \pm 13\text{V}$	●	106	122		104	120		dB
PSRR	Power Supply Rejection Ratio	$V_S = \pm 3\text{V}$ to $\pm 18\text{V}$	●	102	117		96	117		dB
	Input Voltage Range		●	± 13	± 14		± 13	± 14		V
V_{OUT}	Output Voltage Swing	$R_L \geq 2\text{k}\Omega$	●	± 12.5	± 13.5		± 12.0	± 13.5		V
P_d	Power Dissipation per amplifier	No load	●		55	90		60	100	mW

The ● denotes the specifications which apply over the temperature range $0^{\circ}\text{C} \leq T_A \leq 70^{\circ}\text{C}$, $V_S = \pm 15\text{V}$, unless otherwise noted.

SYMBOL	PARAMETER	CONDITIONS		LT1002AC			LT1002C			UNITS
				MIN	TYP	MAX	MIN	TYP	MAX	
V_{OS}	Input Offset Voltage	(Note 2)	●		20	100		30	160	μV
$\frac{\Delta V_{OS}}{\Delta \text{Temp}}$	Average Input Offset Voltage Drift		●		0.2	0.9		0.3	1.3	$\mu\text{V}/^{\circ}\text{C}$
I_{OS}	Input Offset Current		●		0.5	4.2		0.6	5.7	nA
I_B	Input Bias Current		●		± 0.7	± 4.5		± 1.0	± 6.0	nA
A_{VOL}	Large Signal Voltage Gain	$R_L \geq 2\text{k}\Omega$, $V_O = \pm 10\text{V}$	●	350	750		250	750		V/mV
CMRR	Common Mode Rejection Ratio	$V_{CM} = \pm 13\text{V}$	●	108	124		106	123		dB
PSRR	Power Supply Rejection Ratio	$V_S = \pm 3\text{V}$ to $\pm 18\text{V}$	●	105	120		100	120		dB
	Input Voltage Range		●	± 13	± 14		± 13	± 14		V
V_{OUT}	Output Voltage Swing	$R_L \geq 2\text{k}\Omega$	●	± 12.5	± 13.8		± 12.5	± 13.8		V
P_d	Power Dissipation per amplifier	No Load	●		50	85		55	90	mW

MATCHING CHARACTERISTICS

$V_S = \pm 15\text{V}$, $T_A = 25^{\circ}\text{C}$, unless otherwise noted.

SYMBOL	PARAMETER	CONDITIONS		LT1002AM/AC			LT1002M/C			UNITS
				MIN	TYP	MAX	MIN	TYP	MAX	
	Input Offset Voltage Match			–	15	40	–	25	80	μV
I_B^+	Average Non-Inverting Bias Current			–	± 0.6	± 3.5	–	± 0.7	± 4.8	nA
I_{OS}^+	Non-Inverting Offset Current			–	0.6	3.5	–	0.7	6.0	nA
I_{OS}^-	Inverting Offset Current			–	0.6	3.5	–	0.7	6.0	nA
ΔCMRR	Common Mode Rejection Ratio Match	$V_{CM} = \pm 13\text{V}$		110	132	–	108	132	–	dB
ΔPSRR	Power Supply Rejection Ratio Match	$V_S = \pm 3\text{V}$ to $\pm 18\text{V}$		108	130	–	102	128	–	dB
	Channel Separation	$f \leq 10\text{Hz}$ (Note 5)		132	148	–	130	146	–	dB

MATCHING CHARACTERISTICS

The ● denotes the specifications which apply over the temperature range $-55^{\circ}\text{C} \leq T_A \leq 125^{\circ}\text{C}$, $V_S = \pm 15\text{V}$, unless otherwise noted.

SYMBOL	PARAMETER	CONDITIONS		LT1002AM			LT1002M			UNITS
				MIN	TYP	MAX	MIN	TYP	MAX	
	Input Offset Voltage Match		●	–	50	140	–	60	230	μV
	Input Offset Voltage Tracking		●	–	0.3	1.0	–	0.4	1.5	$\mu\text{V}/^{\circ}\text{C}$
I_B^+	Average Non-Inverting Bias Current		●	–	± 1.5	± 6.0	–	± 1.8	± 10.0	nA
I_{OS}^+	Non-Inverting Offset Current		●	–	1.5	6.5	–	1.8	12.0	nA
I_{OS}^-	Inverting Offset Current		●	–	1.5	6.5	–	1.8	12.0	nA
ΔCMRR	Common Mode Rejection Ratio Match	$V_{CM} = \pm 13\text{V}$	●	106	126		102	124	–	dB
ΔPSRR	Power Supply Rejection Ratio Match	$V_S = \pm 3\text{V}$ to $\pm 18\text{V}$	●	102	122		94	120	–	dB

The ● denotes the specifications which apply over the temperature range $0^{\circ}\text{C} \leq T_A \leq 70^{\circ}\text{C}$, $V_S = \pm 15\text{V}$, unless otherwise noted.

SYMBOL	PARAMETER	CONDITIONS		LT1002AC			LT1002C			UNITS
				MIN	TYP	MAX	MIN	TYP	MAX	
	Input Offset Voltage Match		●	–	30	85	–	45	150	μV
	Input Offset Voltage Tracking		●	–	0.3	1.0	–	0.4	1.5	$\mu\text{V}/^{\circ}\text{C}$
I_B^+	Average Non-Inverting Bias Current		●	–	± 1.0	± 4.5	–	± 1.2	± 7.0	nA
I_{OS}^+	Non-Inverting Offset Current		●	–	1.0	5.0	–	1.2	8.5	nA
I_{OS}^-	Inverting Offset Current		●	–	1.0	5.0	–	1.2	8.5	nA
ΔCMRR	Common Mode Rejection Ratio Match	$V_{CM} = \pm 13\text{V}$	●	108	130	–	105	128	–	dB
ΔPSRR	Power Supply Rejection Ratio Match	$V_S = \pm 3\text{V}$ to $\pm 18\text{V}$	●	105	126	–	98	124	–	dB

For MIL-STD components, please refer to LTC 883C data sheet for test listing and parameters.

Note 1: Absolute Maximum Ratings are those values beyond which the life of a device may be impaired.

Note 2: Offset voltage measured with high speed test equipment, approximately 1second after power is applied.

Note 3: This parameter is tested on a sample basis only.

Note 4: Long Term Input Offset Voltage Stability refers to the averaged trend line of V_{OS} versus Time over extended periods after the first 30 days

of operation. Excluding the initial hour of operation, changes in V_{OS} during the first 30 operating days are typically $2.5\mu\text{V}$.

Note 5: Parameter is guaranteed by design.

Note 6: 10Hz noise voltage density is sample tested on every lot. Devices 100% tested at 10Hz are available on request.

Note 7: The V_+ supply terminals are completely independent and may be powered by separate supplies if desired (this approach, however, would sacrifice the advantages of the power supply rejection ratio matching). The V_- supply terminals are both connected to the common substrate and must be tied to the same voltage. Both V_- pins should be used.

TYPICAL PERFORMANCE CHARACTERISTICS

Distribution of Offset Voltage of Individual Amplifiers

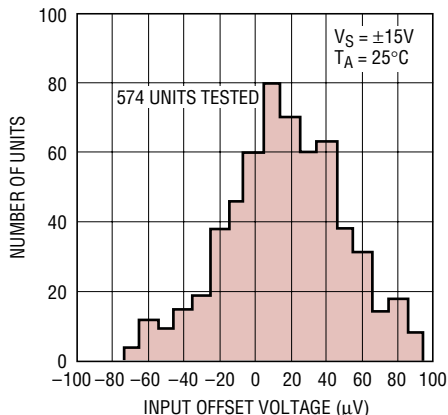

1002 G01

Distribution of Offset Voltage Drift with Temperature (Individual Amplifiers)

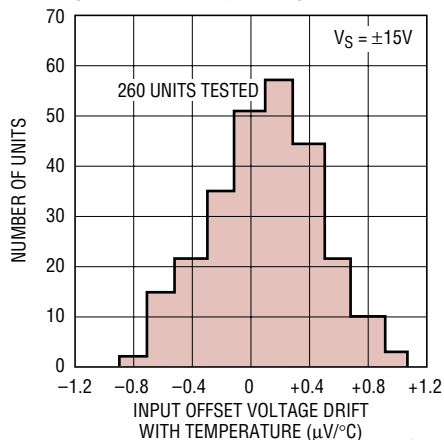

1002 G02

Distribution of Offset Voltage Match Drift with Temperature

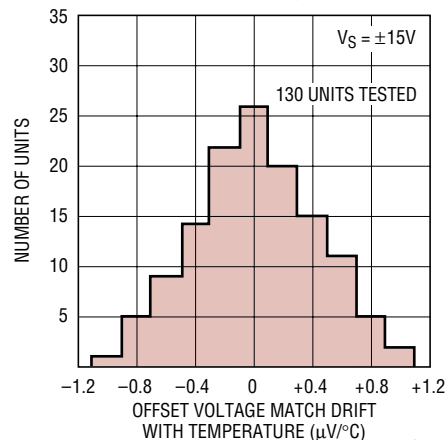

1002 G03

Offset Voltage Drift with Temperature of Six Representative Units

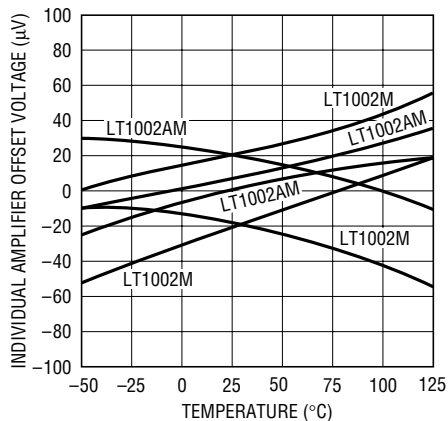

1002 G04

Offset Voltage Tracking with Temperature of Six Representative Units

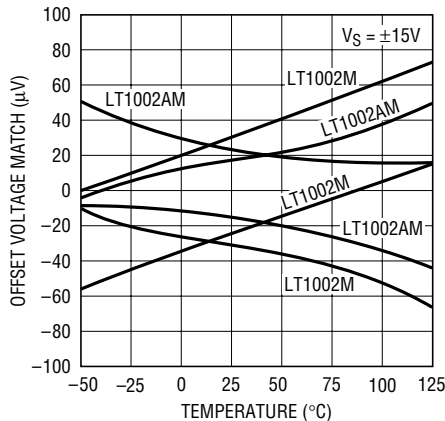

1002 G04

Warm-Up Drift

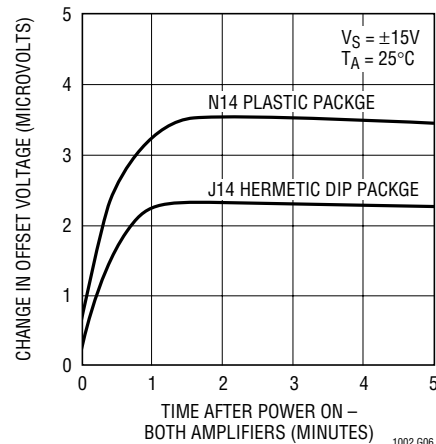

1002 G06

Long Term Stability of Four Representative Units

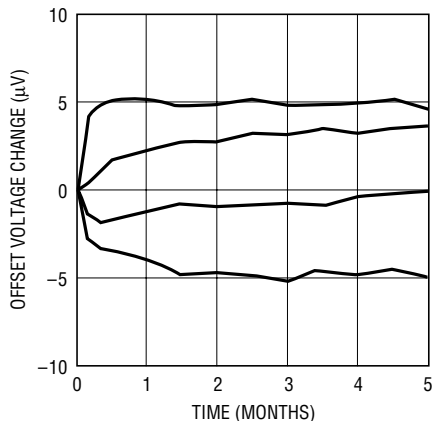

1001 G07

0.1Hz to 10Hz Noise

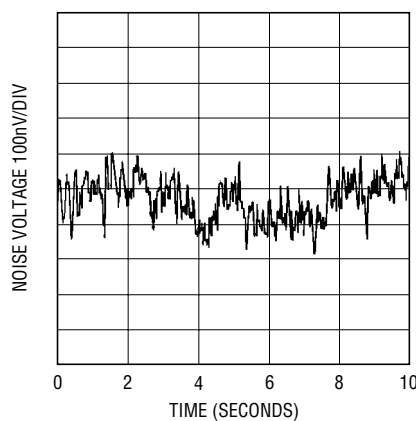

1001 G08

Noise Spectrum

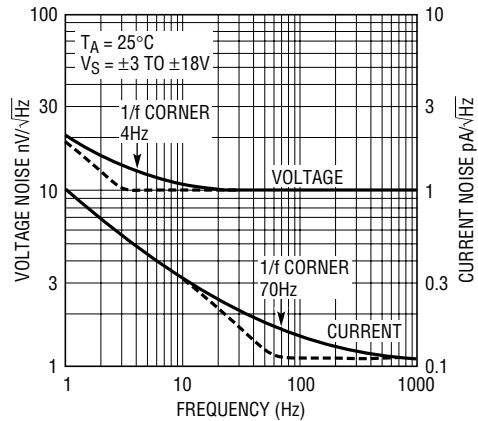

1002 G09

TYPICAL PERFORMANCE CHARACTERISTICS

Matching and Individual Amplifier Bias and Offset Currents vs Temperature

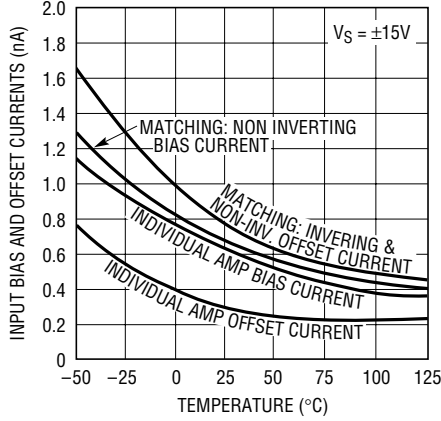

1001 G10

Input Bias Current Over the Common Mode Range

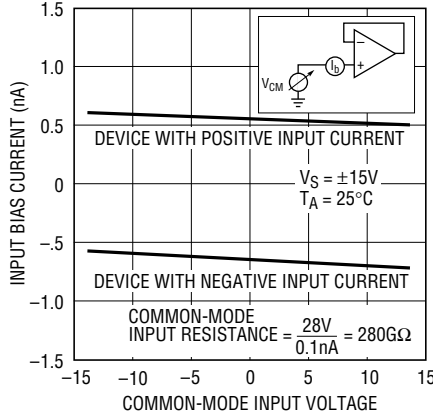

1002 G11

Input Bias Current vs. Differential Input Voltage

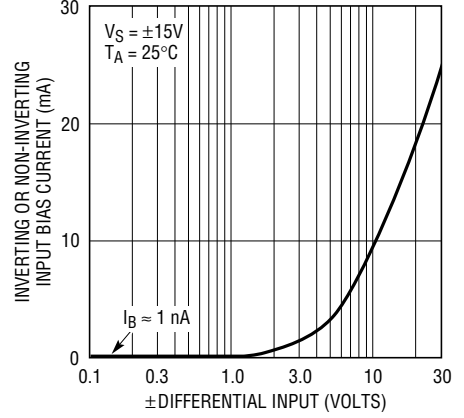

1002 G12

Open Loop Voltage Gain vs Temperature

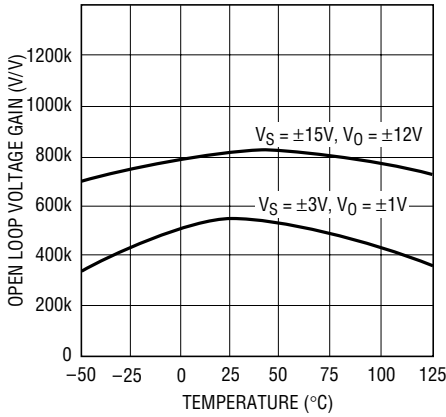

1002 G13

Open Loop Voltage Gain Frequency Response

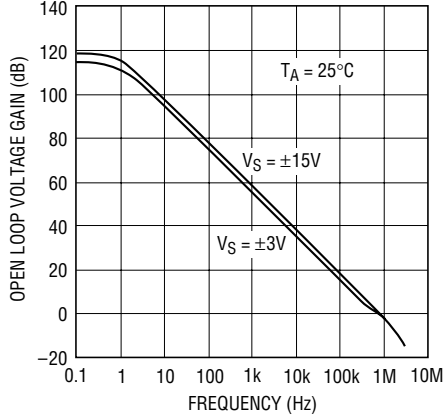

1002 G14

Gain, Phase Shift vs. Frequency

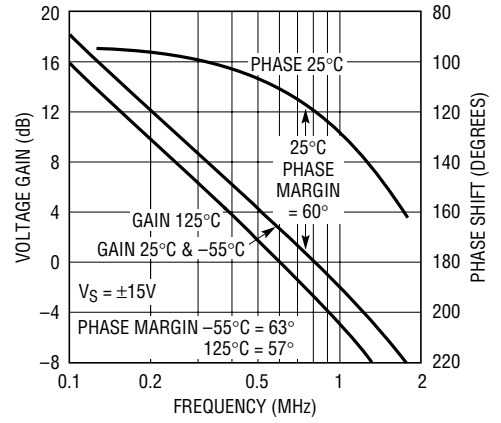

1002 G15

Open Loop Gain Mismatch vs Frequency

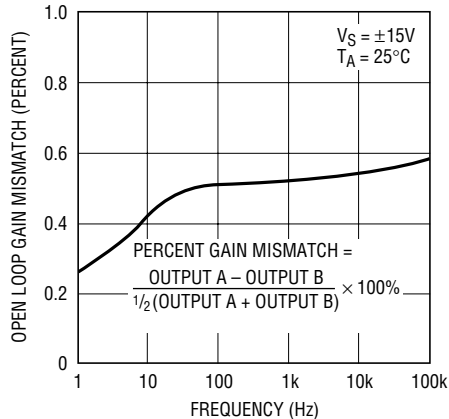

1002 G16

Closed Loop Output Impedance

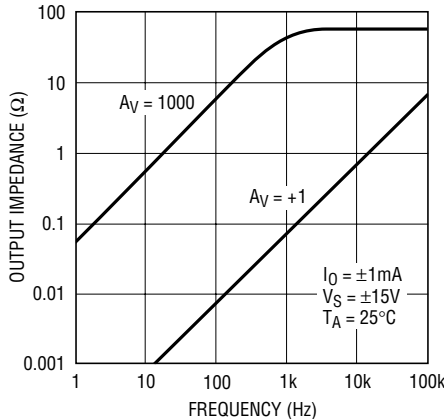

1002 G17

Power Supply Rejection and PSRR Match vs Frequency

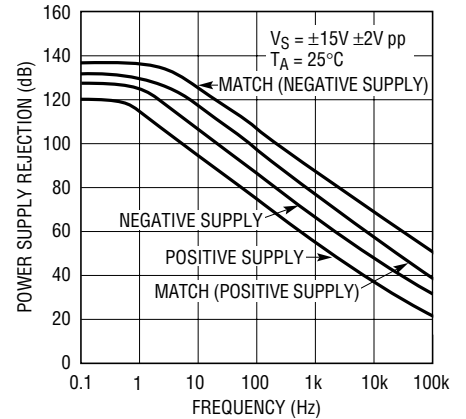

1002 G18

TYPICAL PERFORMANCE CHARACTERISTICS

Channel Separation vs Frequency

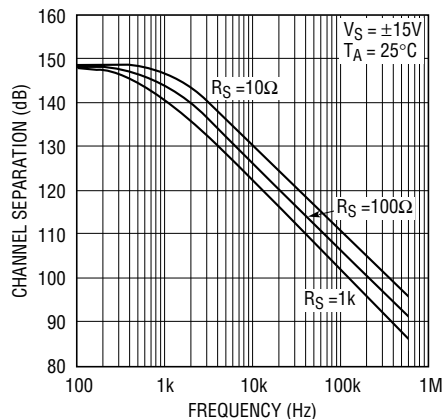

1002 G19

Common Mode Rejection and CMRR Match vs Frequency

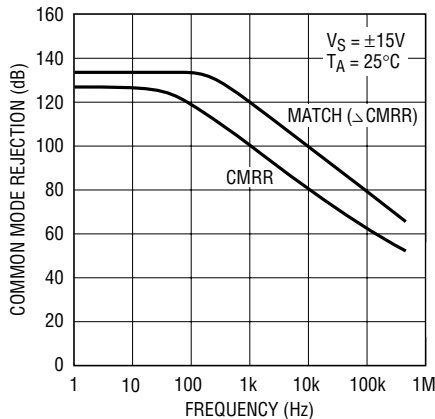

1002 G20

Common Mode Limit vs Temperature

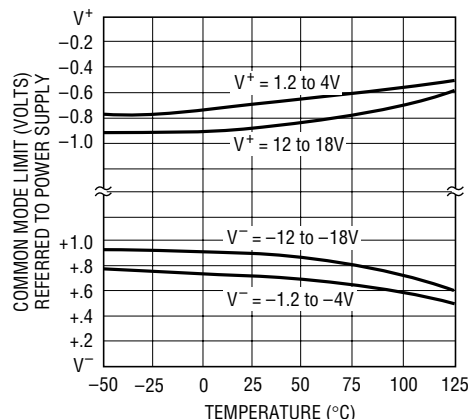

1002 G21

Supply Current vs. Supply Voltage For Each Amplifier

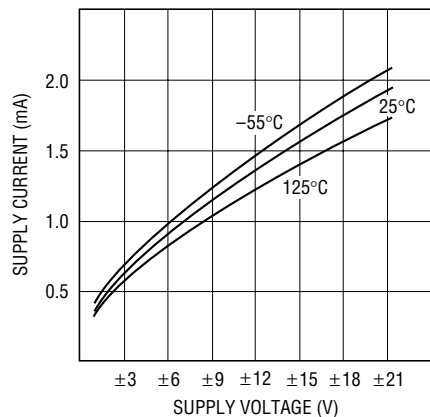

1002 G22

Large Signal Transient Response

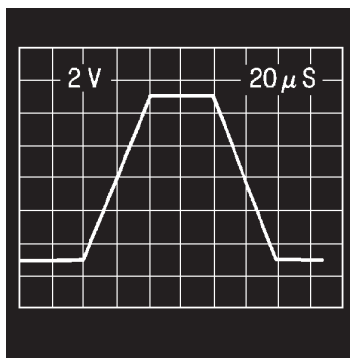

1002 G23

Maximum Undistorted Output vs. Frequency

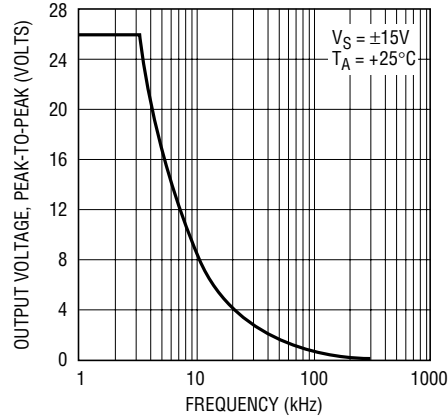

1002 G24

Small Signal Transient Response

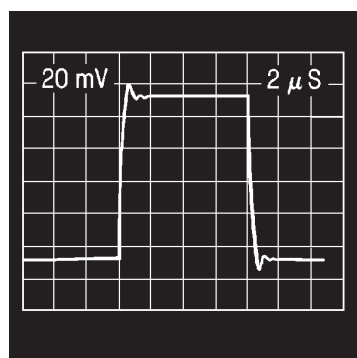

$A_V = +1, C_L = 50\text{pF}$

1002 G25

Voltage Follower Overshoot vs Capacitive Load

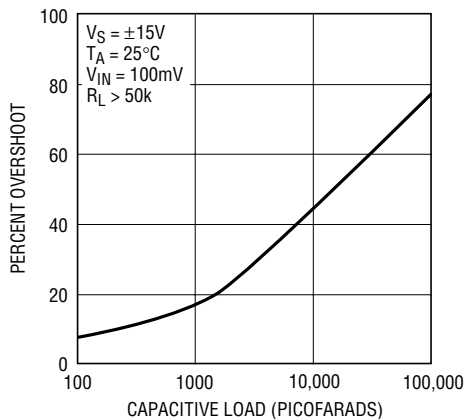

1002 G26

Small Signal Transient Response

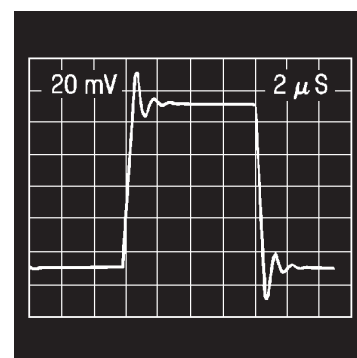

$A_V = +1, C_L = 1000\text{pF}$

1002 G27

TYPICAL PERFORMANCE CHARACTERISTICS

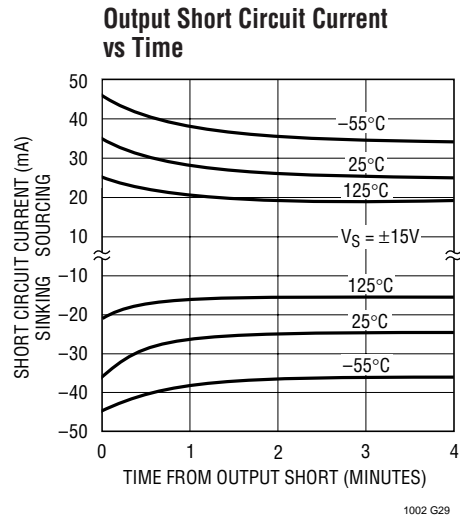
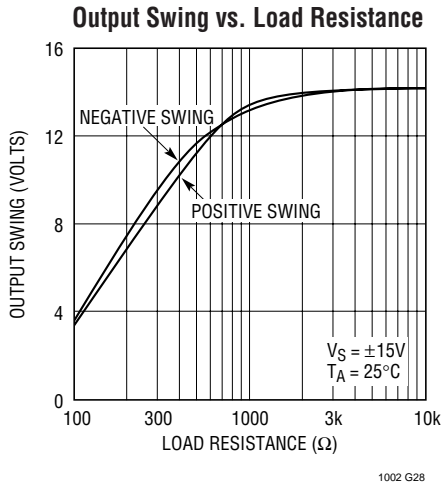

APPLICATIONS INFORMATION

The LT1002 dual amplifier may be inserted directly into OP-10, OP207, OP227 sockets with or without removal of external nulling potentiometers.

Offset Voltage Adjustment The input offset voltage of the LT1002, and its drift with temperature, are permanently trimmed at wafer testing to a low level. However, if further adjustment of V_{OS} is necessary, nulling with a 10k or 20k potentiometer will not degrade drift with temperature. Trimming to a value other than zero creates a drift of $(V_{OS}/300)\mu V/^\circ C$, e.g. if V_{OS} is adjusted to $300\mu V$, the change in drift will be $1\mu V/^\circ C$. The adjustment range with a 10k or 20k pot is approximately $\pm 2.5mV$. If less adjustment range is needed, the sensitivity and resolution of the nulling can be improved by using a smaller pot in conjunction with fixed resistors. The example has an approximate null range of $\pm 100\mu V$.

In matching applications, both amplifiers can be trimmed to zero, or the offset of one amplifier can be trimmed to match the offset of the other. Offset adjustment, however, slightly degrades the gain, common-mode and power-supply rejection match between the two op amps. Fortu-

nately, the guaranteed offset voltage match of the LT1002 is very low, in most applications offset adjustment will be unnecessary.

Standard Adjustment

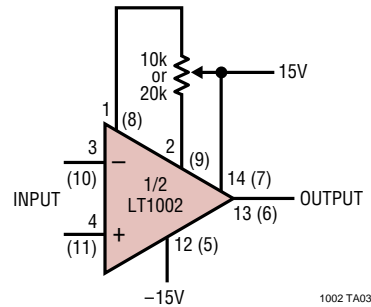

Improved Sensitivity Adjustment

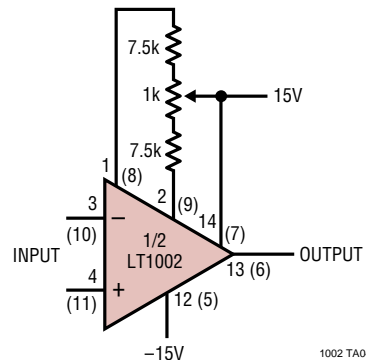

APPLICATIONS INFORMATION

Test Circuit for Offset Voltage and its Drift with Temperature

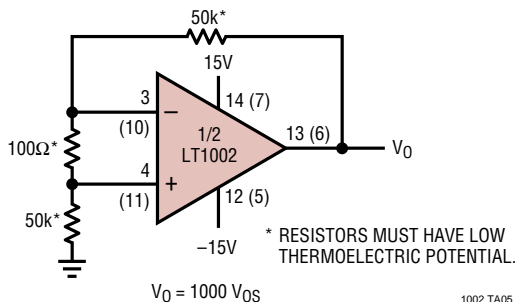

This circuit is also used as burn-in configuration for the LT1002, with supply voltages increased to $\pm 20V$.

Unless proper care is exercised, thermocouple effects, caused by temperature gradients across dissimilar metals at the contacts to the input terminals, can exceed the inherent drift of the amplifier. Air currents should be minimized, package leads should be short, the two input leads should be as close together as possible and maintained at the same temperature.

Channel Separation

This parameter is defined as the ratio of the change in input offset voltage of one amplifier to the change in output voltage of the other amplifier causing the offset change.

At low frequencies the LT1002's channel separation is an almost unmeasurable 148dB. As frequency increases, pin to pin capacitance of the package, between the output of one amplifier and the inputs of the other, becomes dominant. Since these pins are non-adjacent, the capacitance is only 0.02pF. To maintain the LT1002's excellent channel separation at higher frequencies, the socket and PC board capacitances should be minimized.

0.1Hz to 10Hz Noise Test Circuit

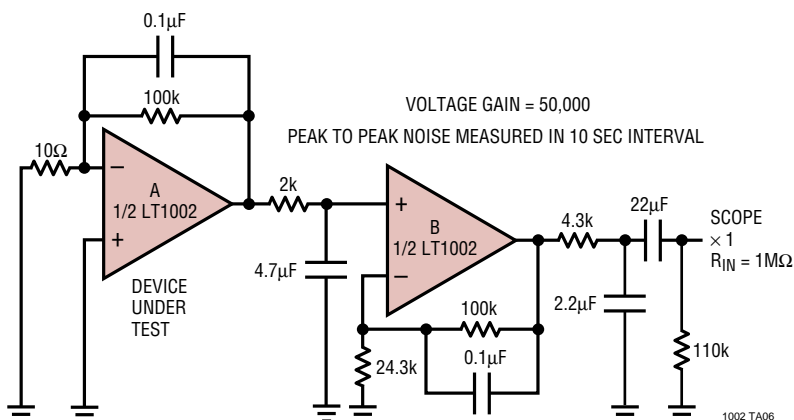

The device under test should be warmed up for three minutes and shielded from air currents. Turn the device 180° to measure the noise of side B.

Power supplies

The LT1002 is specified over a wide range of power supply voltages from $\pm 3V$ to $\pm 18V$. Operation with lower supplies is possible, down to $\pm 1.2V$ (two Ni-Cad batteries). However, with $\pm 1.2V$ supplies, the device is stable only in closed loop gains of +2 or higher (or inverting gain of one or higher).

The $V+$ supply terminals are completely independent and may be powered by separate supplies if desired (this approach, however, would sacrifice the advantages of the power supply rejection ratio matching). The $V-$ supply terminals are both connected to the common substrate and must be tied to the same voltage. Both $V-$ pins should be used.

APPLICATIONS INFORMATION

Advantages of Matched Dual Op Amps In many applications the performance of a system depends on the matching between two operational amplifiers rather than the individual characteristics of the two op amps. Two or three op amp instrumentation amplifiers, tracking voltage references and low drift active filters are some of the circuits requiring matching between two op amps.

The well-known triple op amp configuration illustrates these concepts. Output offset is a function of the difference between the offsets of the two halves of the LT1002. This error cancellation principle holds for a considerable number of input referred parameters in addition to offset voltage and its drift with temperature. Input bias current will be the average of the two non-inverting input currents (I_B^+). The difference between these two currents (I_{OS}^+) is the offset current of the instrumentation amplifier. The difference between the inverting input currents (I_{OS}^-) will cause errors flowing through R1, R2, and R3. Common-mode and power supply rejections will be dependent only on the match between the two amplifiers (assuming perfect resistor matching).

The concepts of common mode and power supply rejection ratio match ($\Delta CMRR$ and $\Delta PSRR$) are best demonstrated with a numerical example:

Assume $CMRR_A = +1.0\mu V/V$ or 120dB, and $CMRR_B = +0.75\mu V/V$ or 122.5dB, then $\Delta CMRR = 0.25\mu V/V$ or 132dB; if $CMRR_B = -0.75\mu V/V$ which is still 122.5dB, then $\Delta CMRR = 1.75\mu V/V$ or 115dB.

Clearly, the LT1002, by specifying and guaranteeing all of these matching parameters, can significantly improve the performance of matching dependent circuits.

Three Op Amp Instrumentation Amplifier

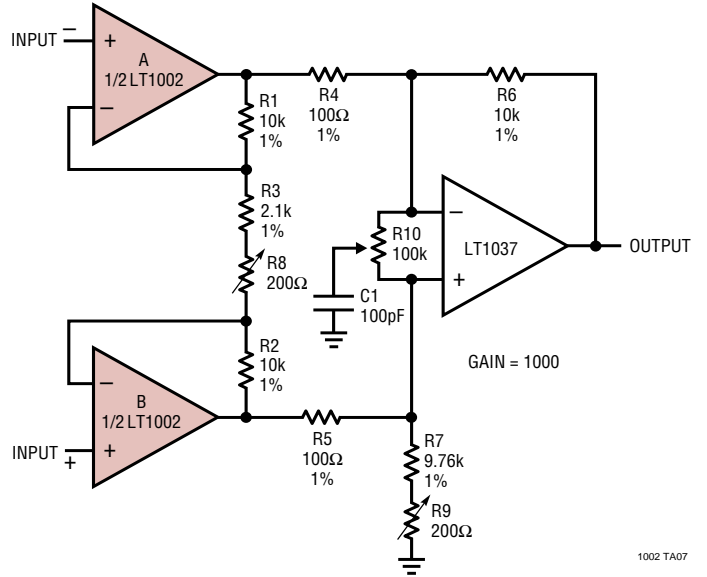

- Trim R8 for gain
- Trim R9 for DC common mode rejection
- Trim R10 for AC common mode rejection

Typical performance of the instrumentation amplifier:

- Input offset voltage = 25 μV
- Input bias current = 0.7nA
- Input resistance = 200 G Ω
- Input offset current = 0.6nA
- Input noise = 0.5 μV p-p
- Power bandwidth ($V_0 = \pm 10V$) = 80kHz

1002 TA07

APPLICATIONS INFORMATION

Precision $\pm 10V$ Reference

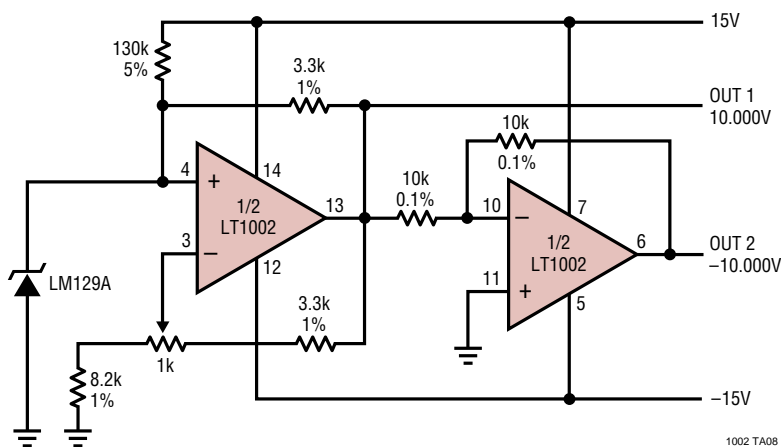

The LT1002 contributes less than 5% of the total drift with temperature, noise and long term drift of the reference.

The accuracy of the $-10V$ output is limited by the matching of the two 10k resistors.

Dual Limit Microvolt Comparator

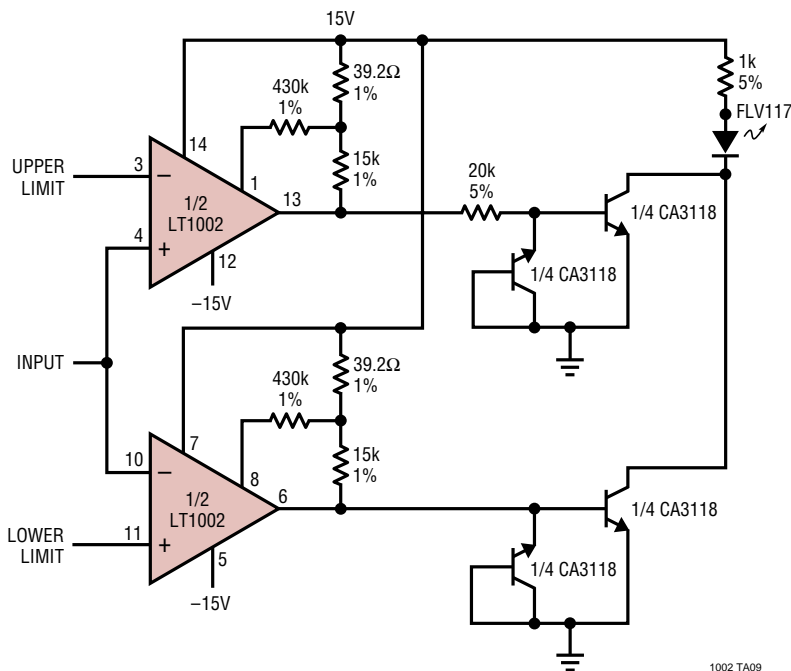

When the upper or lower limit is exceeded the LED lights up. Positive feedback to one of the nulling terminals creates 5 to 20 μV of hysteresis on both amplifiers. This

feedback changes the offset voltage of the LT1002 by less than 5 μV . Therefore, the basic accuracy of the comparator is limited only by the low offset voltage of the LT1002.

APPLICATIONS INFORMATION

Two Op Amp Instrumentation Amplifier

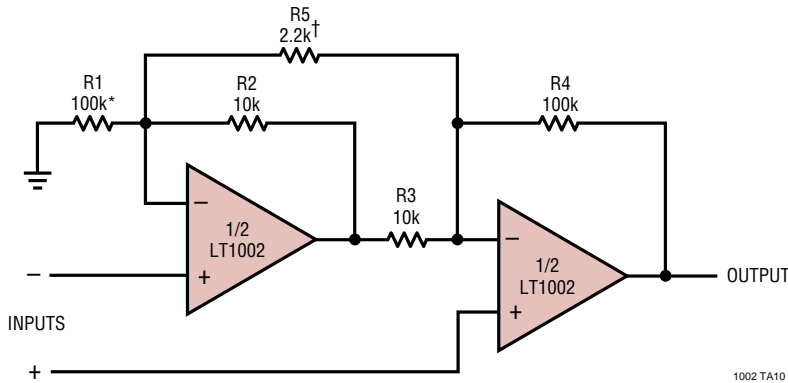

* TRIM FOR COMMON-MODE REJECTION

† TRIM FOR GAIN

$$\text{GAIN} = \frac{R4}{R3} \left[1 + \frac{1}{2} \left(\frac{R2}{R1} + \frac{R3}{R4} \right) + \frac{R2 + R3}{R5} \right] = 100$$

Precision Amplifier Drives 500Ω Load to ±10V

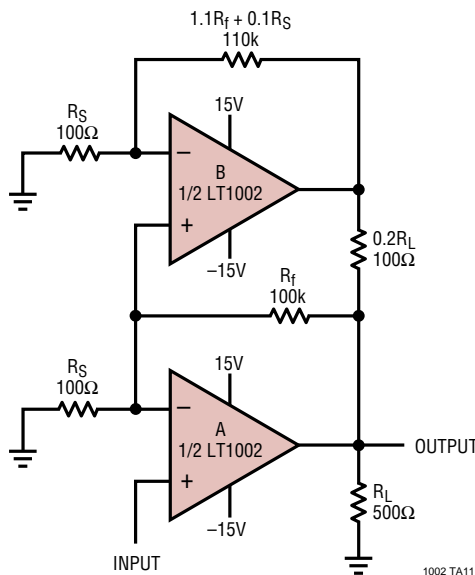

This application utilizes the guaranteed 10mA load driving capability of the LT1002. The offset voltage of amplifier A is the offset of the configuration. Amplifier B provides the additional 10mA load current. When load resistor R_L is

removed, amplifier A sinks this current without affecting accuracy. In the gain of 1000 configuration shown, approximately 0.3% gain accuracy can be realized.

APPLICATIONS INFORMATION

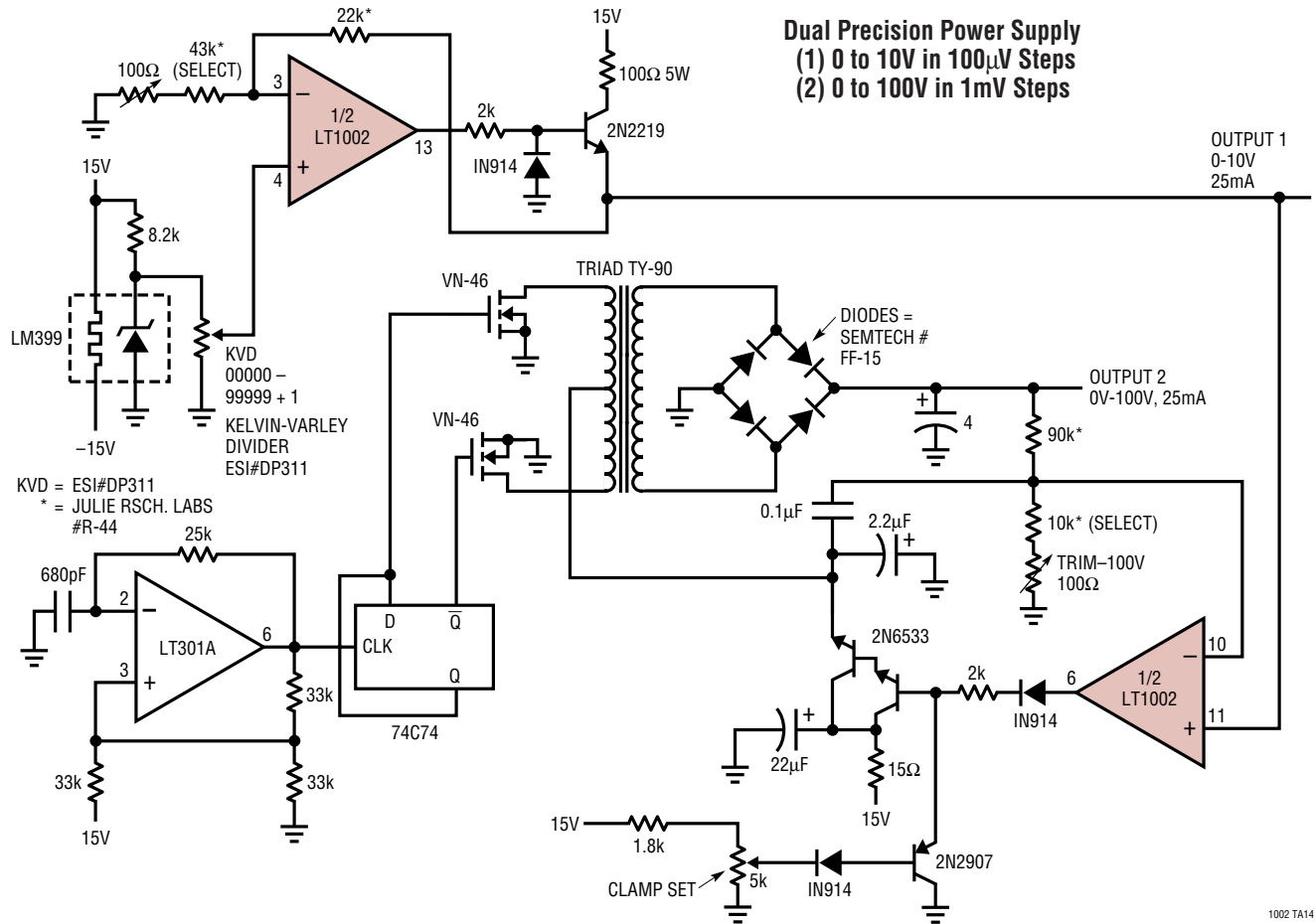

SCHEMATIC DIAGRAM

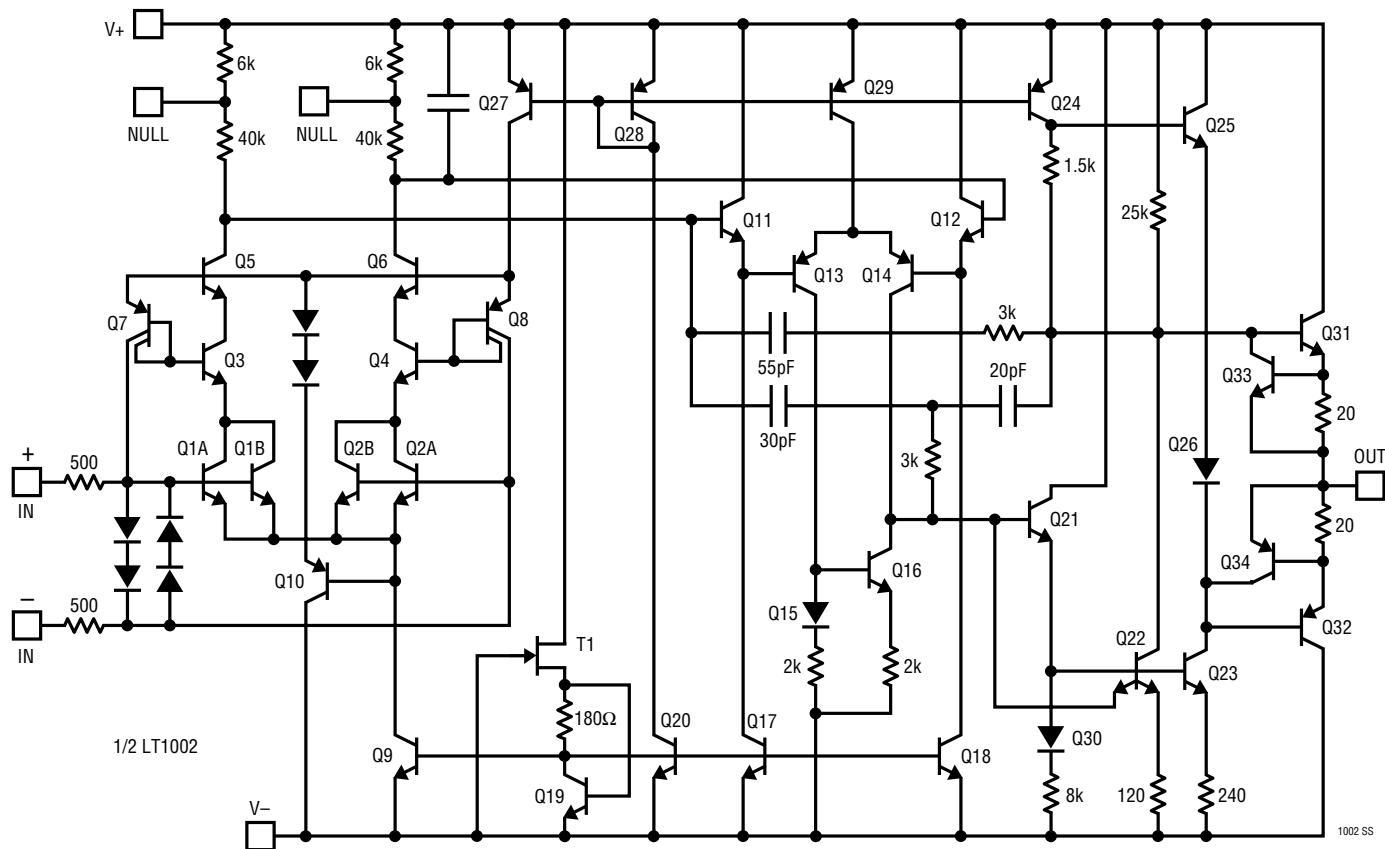

PACKAGE DESCRIPTION

J Package
14-Lead CERDIP (Narrow .300 Inch, Hermetic)
 (Reference LTC DWG # 05-08-1110)

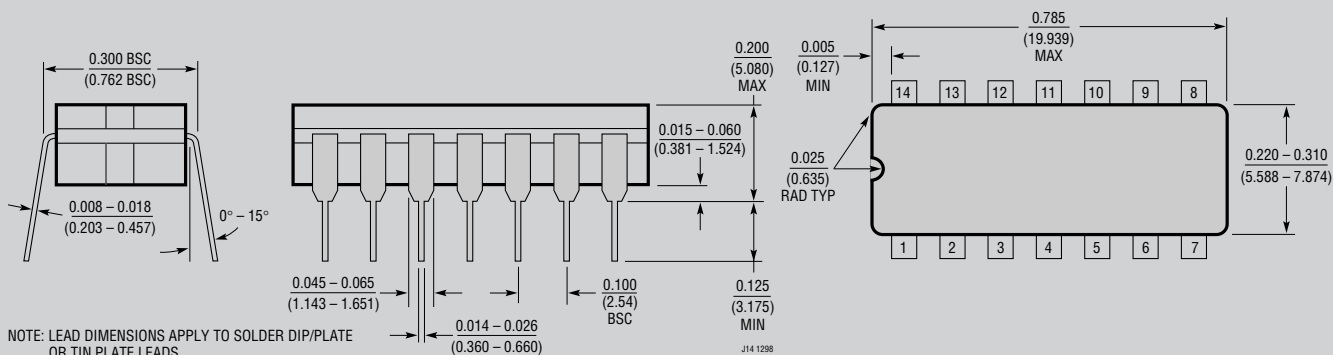

OBsolete PACKAGE

PACKAGE DESCRIPTION

N Package
14-Lead PDIP (Narrow .300 Inch)
 (Reference LTC DWG # 05-08-1510)

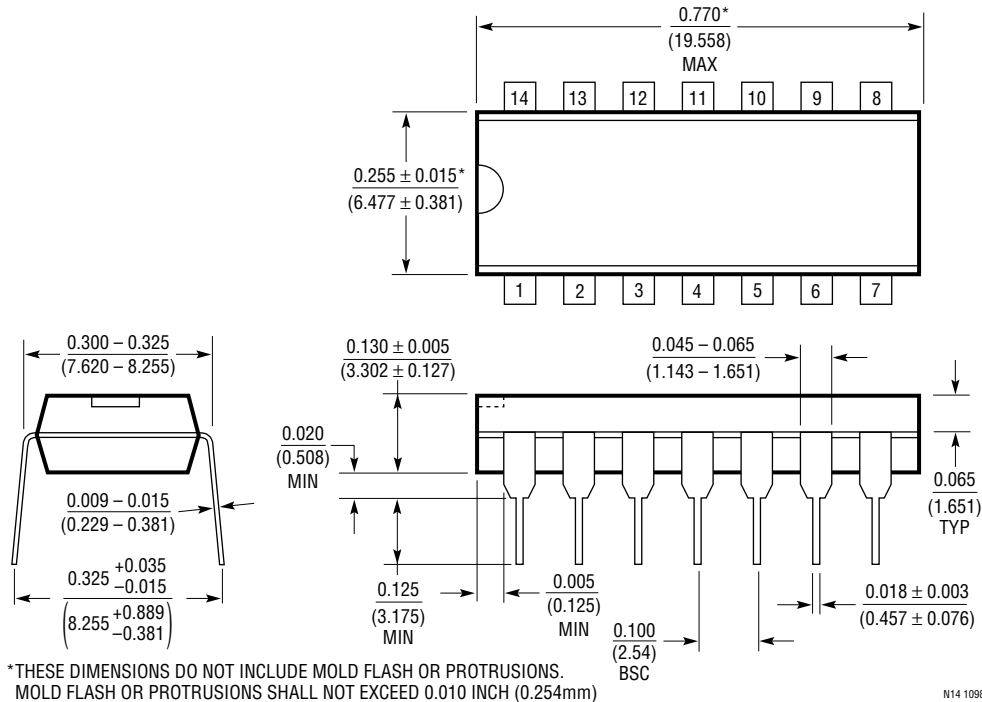

RELATED PARTS

PART NUMBER	DESCRIPTION	COMMENTS
LT1001	Single LT1002	60μV V _{OS} , 1μV/°C Precision Op Amp
LT1884/LT1885	Dual/Quad Precision Op Amp with Rail-to-Rail Output	50μV Max V _{OS} , 400pA Max I _B