

FEATURES

- Maximum Offset Voltage Drift: $0.05\mu\text{V}/^\circ\text{C}$
- High Voltage Operation: $\pm 18\text{V}$
- No External Components Required
- Maximum Offset Voltage: $5\mu\text{V}$
- Low Noise: $1.5\mu\text{V}_{\text{P-P}}$ (0.1Hz to 10Hz)
- Minimum Voltage Gain: 125dB
- Minimum CMRR: 106dB
- Minimum PSRR: 110dB
- Low Supply Current: 0.9mA/Amplifier
- Single Supply Operation: 4.75V to 36V
- Input Common Mode Range Includes Ground
- Typical Overload Recovery Time: 20ms
- Available in 8-Lead N8 and 16-Lead SW Packages

APPLICATIONS

- Strain Gauge Amplifiers
- Instrumentation Amplifiers
- Electronic Scales
- Medical Instrumentation
- Thermocouple Amplifiers
- High Resolution Data Acquisition

DESCRIPTION

The LTC[®]1151 is a high voltage, high performance dual zero-drift operational amplifier. The two sample-and-hold capacitors per amplifier required externally by other chopper amplifiers are integrated on-chip. The LTC1151 also incorporates proprietary high voltage CMOS structures which allow operation at up to 36V total supply voltage.

The LTC1151 has a typical offset voltage of $0.5\mu\text{V}$, drift of $0.01\mu\text{V}/^\circ\text{C}$, 0.1Hz to 10Hz input noise voltage of $1.5\mu\text{V}_{\text{P-P}}$, and a typical voltage gain of 140dB. It has a slew rate of $3\text{V}/\mu\text{s}$ and a gain-bandwidth product of 2.5MHz with a supply current of 0.9mA per amplifier. Overload recovery times from positive and negative saturation are 3ms and 20ms, respectively.

The LTC1151 is available in a standard 8-lead plastic DIP package as well as a 16-lead wide body SO. The LTC1151 is pin compatible with industry-standard dual op amps and runs from standard $\pm 15\text{V}$ supplies, allowing it to plug in to most standard bipolar op amp sockets while offering significant improvement in DC performance.

 LTC and LT are registered trademarks of Linear Technology Corporation. All other trademarks are the property of their respective owners.

TYPICAL APPLICATION

$\pm 15\text{V}$ Dual Thermocouple Amplifier

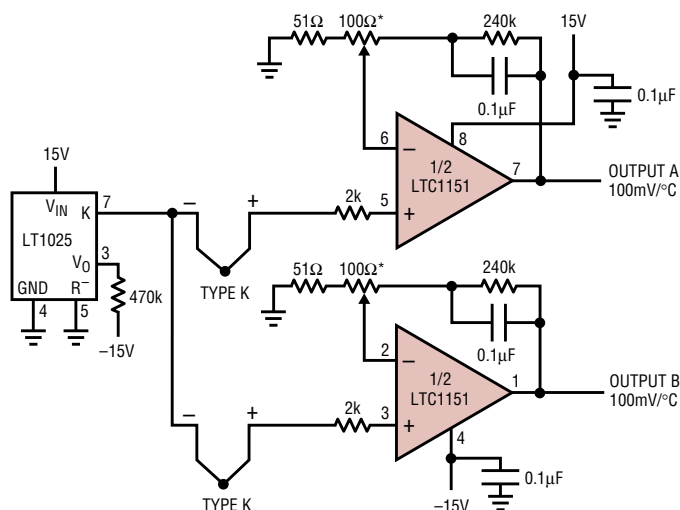

* FULL SCALE TRIM: TRIM FOR 10.0V OUTPUT WITH THERMOCOUPLE AT 100°C

1151 TA01

Noise Spectrum

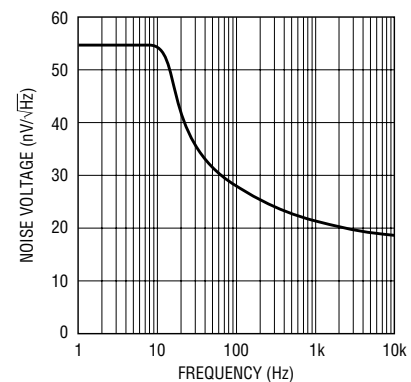

1151 TA02

LTC1151

ABSOLUTE MAXIMUM RATINGS

(Note 1)

Total Supply Voltage (V^+ to V^-)	36V	Operating Temperature Range	
Input Voltage (Note 2)	($V^+ + 0.3V$) to ($V^- - 0.3V$)	LTC1151C	0°C to 70°C
Output Short Circuit Duration	Indefinite	Storage Temperature Range	-65°C to 150°C
Burn-In Voltage	36V	Lead Temperature (Soldering, 10 sec)	300°C

PACKAGE/ORDER INFORMATION

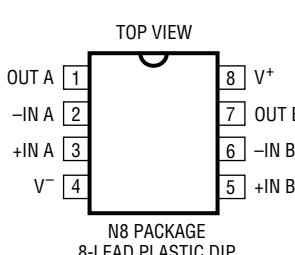
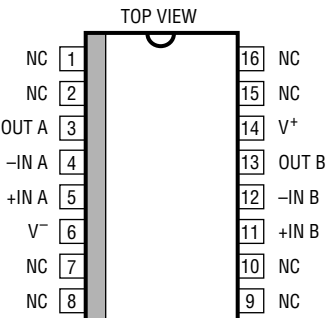
 <p>N8 PACKAGE 8-LEAD PLASTIC DIP</p> <p>$T_{JMAX} = 110^{\circ}C, \theta_{JA} = 130^{\circ}C/W$</p>	ORDER PART NUMBER	 <p>SW PACKAGE 16-LEAD PLASTIC SO (WIDE)</p> <p>$T_{JMAX} = 110^{\circ}C, \theta_{JA} = 200^{\circ}C/W$</p>	ORDER PART NUMBER
	LTC1151CN8		LTC1151CSW
Order Options Tape and Reel: Add #TR Lead Free: Add #PBF Lead Free Tape and Reel: Add #TRPBF Lead Free Part Marking: http://www.linear.com/leadfree/			

Consult LTC Marketing for parts specified with wider operating temperature ranges.

ELECTRICAL CHARACTERISTICS

The ● denotes the specifications which apply over the full operating temperature range, otherwise specifications are at $T_A = 25^{\circ}C$. $V_S = \pm 15V$, unless otherwise specified.

PARAMETER	CONDITIONS	LTC1151C			UNITS
		MIN	TYP	MAX	
Input Offset Voltage	$T_A = 25^{\circ}C$ (Note 3)		±0.5	±5	μV
Average Input Offset Drift	(Note 3)	●	±0.01	±0.05	μV/°C
Long Term Offset Voltage Drift			50		nV/√mo
Input Offset Current	$T_A = 25^{\circ}C$	●	±20	±200 ±0.5	pA nA
Input Bias Current	$T_A = 25^{\circ}C$	●	±15	±100 ±0.5	pA nA
Input Noise Voltage	$R_S = 100\Omega, 0.1Hz$ to 10Hz $R_S = 100\Omega, 0.1Hz$ to 1Hz		1.5 0.5		μV _{p-p} μV _{p-p}
Input Noise Current	$f = 10Hz$ (Note 4)		2.2		fA/√Hz
Input Voltage Range	Positive	●	12	13.2	V
	Negative	●	-15	-15.3	V
Common Mode Rejection Ratio	$V_{CM} = V^-$ to 12V	●	106	130	dB
Power Supply Rejection Ratio	$V_S = \pm 2.375V$ to ±16V	●	110	130	dB
Large-Signal Voltage Gain	$R_L = 10k, V_{OUT} = \pm 10V$	●	125	140	dB

1151fa

ELECTRICAL CHARACTERISTICS

The ● denotes the specifications which apply over the full operating temperature range, otherwise specifications are at $T_A = 25^\circ\text{C}$. $V_S = \pm 15\text{V}$, unless otherwise specified.

PARAMETER	CONDITIONS	LTC1151C			UNITS
		MIN	TYP	MAX	
Maximum Output Voltage Swing	$R_L = 10\text{k}$, $T_A = 25^\circ\text{C}$	●	± 13.5	± 14.50	V
	$R_L = 10\text{k}$		$+10.5/-13.5$		V
	$R_L = 100\text{k}$			± 14.95	V
Slew Rate	$R_L = 10\text{k}$, $C_L = 50\text{pF}$		2.5		V/ μs
Gain-Bandwidth Product			2		MHz
Supply Current per Amplifier	No Load, $T_A = 25^\circ\text{C}$	●	0.9	1.5	mA
	No Load			2.0	mA
Internal Sampling Frequency			1000		Hz

The ● denotes the specifications which apply over the full operating temperature range, otherwise specifications are at $T_A = 25^\circ\text{C}$. $V_S = 5\text{V}$, unless otherwise specified.

Input Offset Voltage	$T_A = 25^\circ\text{C}$ (Note 3)		± 0.05	± 5	μV
Average Input Offset Drift	(Note 3)	●	± 0.01	± 0.05	$\mu\text{V}/^\circ\text{C}$
Long Term Offset Voltage Drift			50		nV/ $\sqrt{\text{mo}}$
Input Offset Current	$T_A = 25^\circ\text{C}$		± 10	100	pA
Input Bias Current	$T_A = 25^\circ\text{C}$		± 5	50	pA
Input Noise Voltage	$R_S = 100\Omega$, 0.1Hz to 10Hz $R_S = 100\Omega$, 0.1Hz to 1Hz		2.0		$\mu\text{V}_{\text{P-P}}$
			0.7		$\mu\text{V}_{\text{P-P}}$
Input Noise Current	$f = 10\text{Hz}$ (Note 4)		1.3		fA/ $\sqrt{\text{Hz}}$
Input Voltage Range	Positive		2.7	3.2	V
	Negative		0	-0.3	V
Common Mode Rejection Ratio	$V_{\text{CM}} = 0\text{V}$ to 2.7V		110		dB
Power Supply Rejection Ratio	$V_S = \pm 2.375\text{V}$ to $\pm 16\text{V}$	●	110	130	dB
Large-Signal Voltage Gain	$R_L = 10\text{k}$, $V_{\text{OUT}} = 0.3\text{V}$ to 4.5V	●	115	140	dB
Maximum Output Voltage Swing	$R_L = 10\text{k}$ to GND		4.85		V
	$R_L = 100\text{k}$ to GND		4.97		V
Slew Rate	$R_L = 10\text{k}$, $C_L = 50\text{pF}$		1.5		V/ μs
Gain Bandwidth Product			1.5		MHz
Supply Current per Amplifier	No Load, $T_A = 25^\circ\text{C}$	●	0.5	1.0	mA
				1.5	mA
Internal Sampling Frequency			750		Hz

Note 1: Absolute Maximum Ratings are those values beyond which the life of a device may be impaired.

Note 2: Connecting any terminal to voltages greater than V^+ or less than V^- may cause destructive latch-up. It is recommended that no sources operating from external supplies be applied prior to power-up of the LTC1151.

Note 3: These parameters are guaranteed by design. Thermocouple effects preclude measurement of these voltage levels in high speed automatic test systems. V_{OS} is measured to a limit determined by test equipment capability.

Note 4: Current Noise is calculated from the formula:

$$I_N = \sqrt{(2q \cdot I_b)}$$

where $q = 1.6 \times 10^{-19}$ Coulomb.

TYPICAL PERFORMANCE CHARACTERISTICS

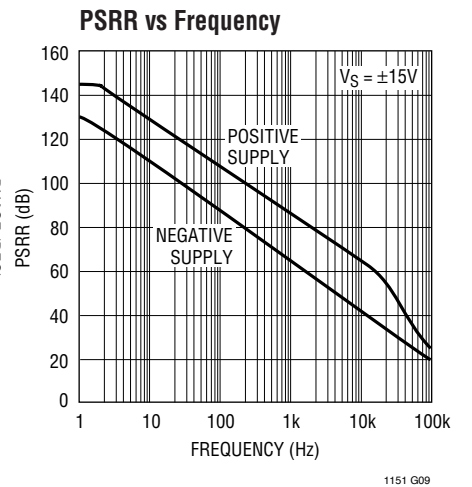
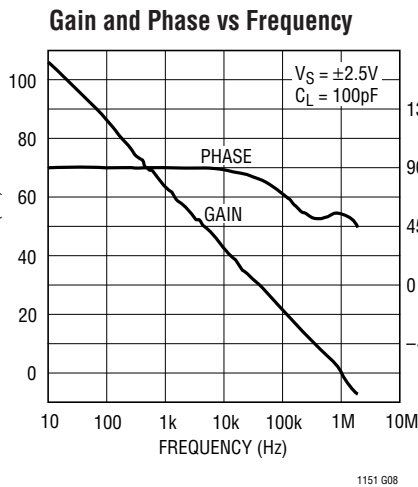
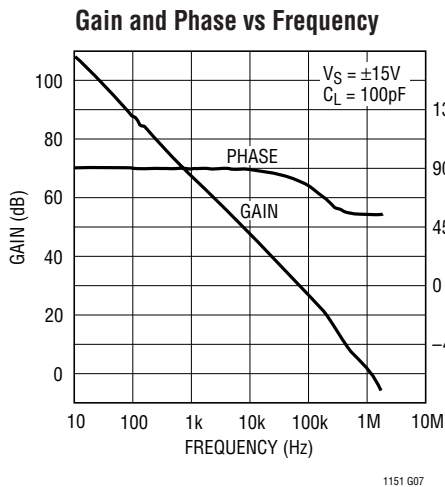
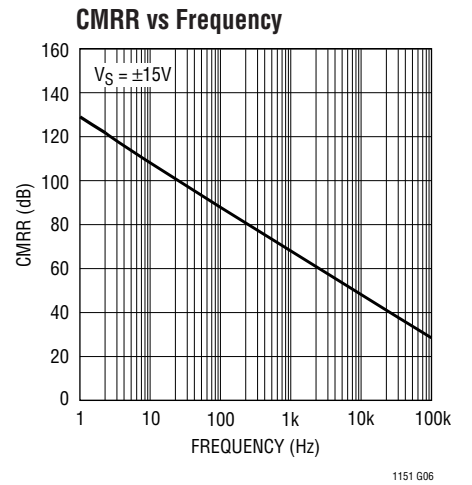
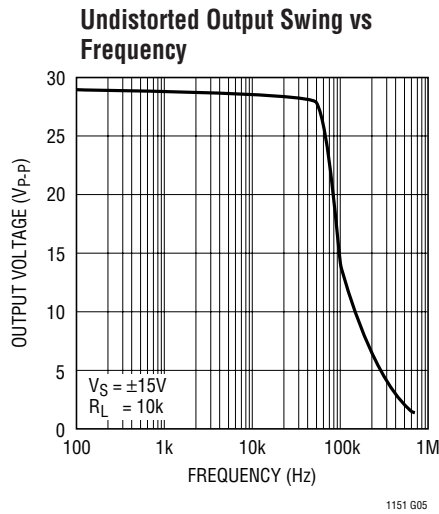
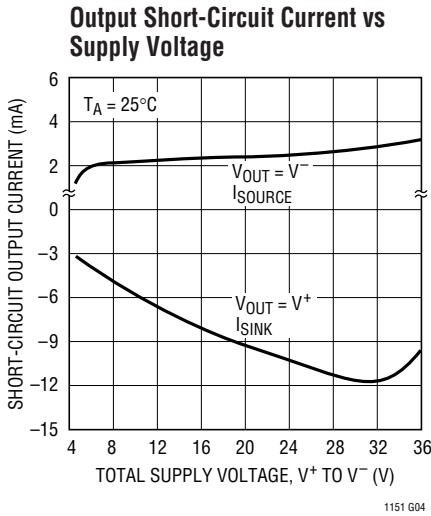
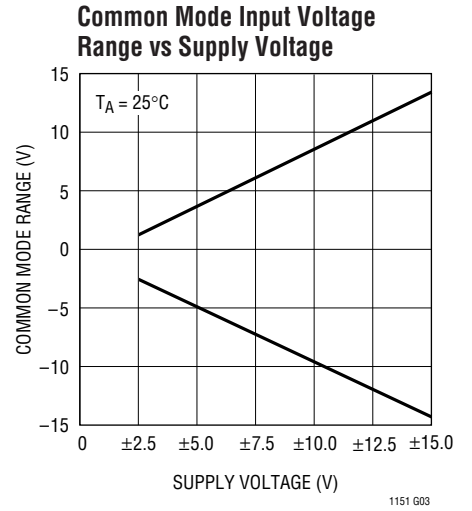
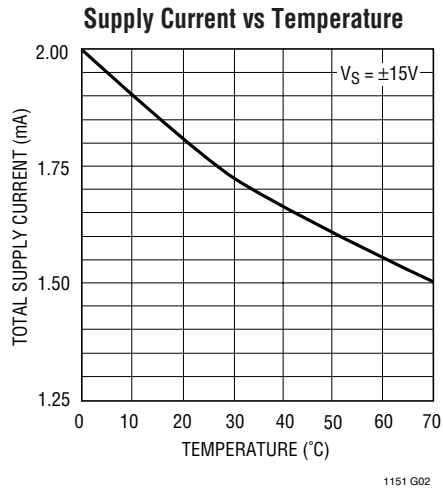
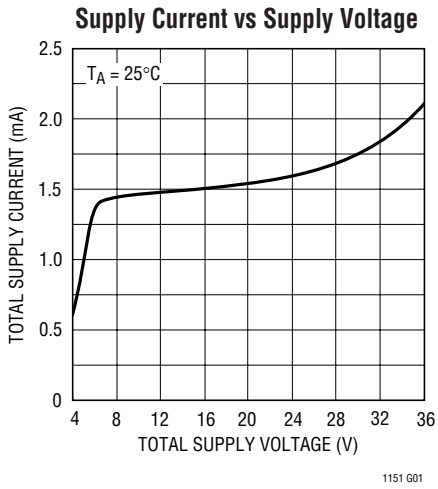

TYPICAL PERFORMANCE CHARACTERISTICS

Input Bias Current Magnitude vs Temperature

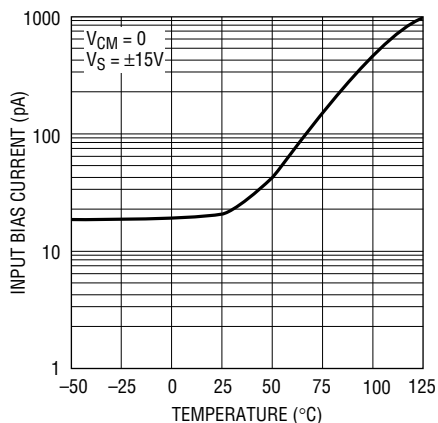

1151 G10

Input Bias Current Magnitude vs Supply Voltage

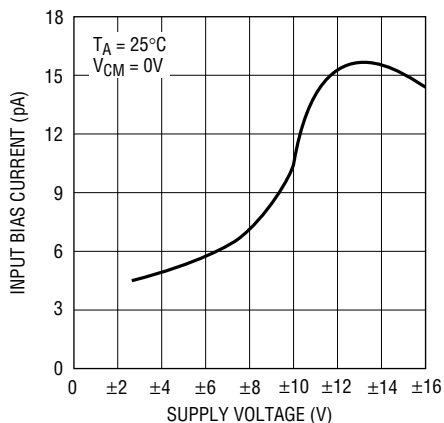

1151 G11

Input Bias Current vs Input Common Mode Voltage

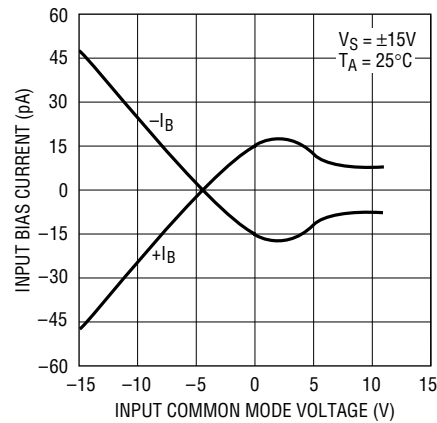

1151 G12

0.1Hz to 10Hz Noise

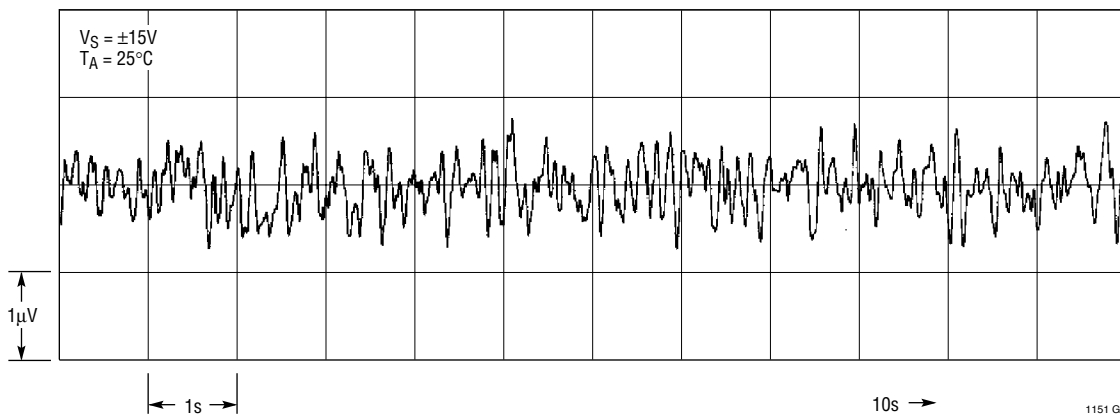

1151 G13

Small-Signal Transient Response

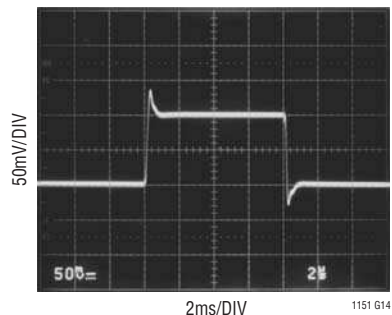

1151 G14

$V_S = \pm 15V, A_V = 1$
 $C_L = 100pF, R_L = 10k$

Large-Signal Transient Response

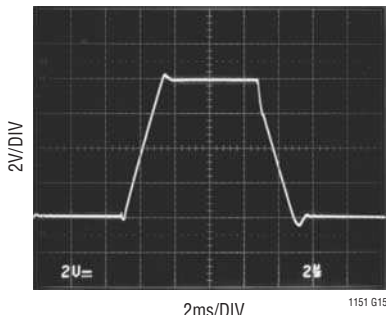

1151 G15

$V_S = \pm 15V, A_V = 1$
 $C_L = 100pF, R_L = 10k$

Negative Overload Recovery

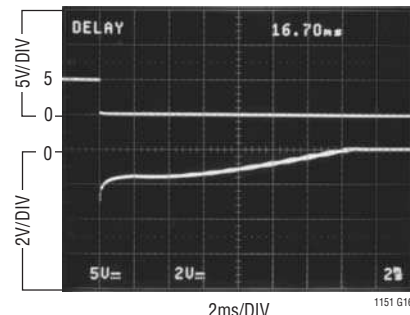

1151 G16

$V_S = \pm 15V, A_V = -100$
NOTE: POSITIVE OVERLOAD RECOVERY IS TYPICALLY 3ms.

TEST CIRCUITS

Offset Voltage Test Circuit

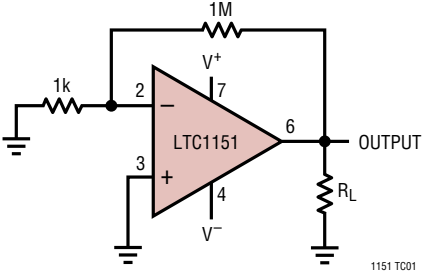

1151 T001

DC-10Hz Noise Test Circuit

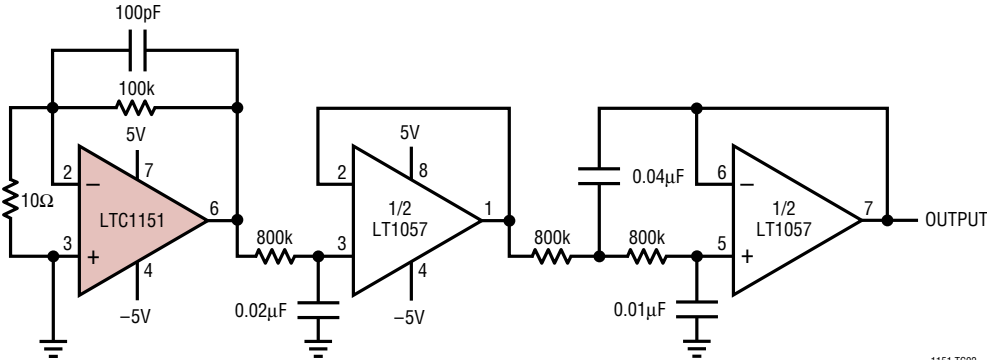

1151 T002

APPLICATIONS INFORMATION

ACHIEVING PICOAMPERE/MICROVOLT PERFORMANCE

Picoamperes

In order to realize the picoampere level of accuracy of the LTC1151 proper care must be exercised. Leakage currents in circuitry external to the amplifier can significantly degrade performance. High quality insulation should be used (e.g., Teflon); cleaning of all insulating surfaces to remove fluxes and other residues will probably be necessary, particularly for high temperature performance. Surface coating may be necessary to provide a moisture barrier in high humidity environments.

Board leakage can be minimized by encircling the input connections with a guard ring operated at a potential close to that of the inputs: in inverting configurations the guard ring should be tied to ground; in noninverting connections to the inverting input. Guarding both sides of the printed circuit board is required. Bulk leakage reduction depends on the guard ring width.

Microvolts

Thermocouple effects must be considered if the LTC1151's ultra low drift is to be fully utilized. Any connection of dissimilar metals forms a thermoelectric junction producing an electric potential which varies with temperature (Seebeck effect). As temperature sensors, thermocouples exploit this phenomenon to produce useful information. In low drift amplifier circuits the effect is a primary source of error.

Connectors, switches, relay contacts, sockets, resistors, solder, and even copper wire are all candidates for thermal EMF generation. Junctions of copper wire from different manufacturers can generate thermal EMFs of $200\text{nV}/^\circ\text{C}$; four times the maximum drift specification of the LTC1151.

Minimizing thermal EMF-induced errors is possible if judicious attention is given to circuit board layout and component selection. It is good practice to minimize the number of junctions in the amplifier's input signal path. Avoid connectors, sockets, switches and relays where possible. In instances where this is not possible, attempt to balance the number and type of junctions so that differential cancellation occurs. Doing this may involve deliberately introducing junctions to offset unavoidable junctions.

Figure 1 is an example of the introduction of an unnecessary resistor to promote differential thermal balance. Maintaining compensating junctions in close physical proximity will keep them at the same temperature and reduce thermal EMF errors.

When connectors, switches, relays and/or sockets are necessary they should be selected for low thermal EMF activity. The same techniques of thermally balancing and coupling the matching junctions are effective in reducing the thermal EMF errors of these components.

APPLICATIONS INFORMATION

Resistors are another source of thermal EMF errors. Table 1 shows the thermal EMF generated for different resistors. The temperature gradient across the resistor is important, not the ambient temperature. There are two junctions formed at each end of the resistor and if these junctions are at the same temperature, their thermal EMFs will cancel each other. The thermal EMF numbers are approximate and vary with resistor value. High values give higher thermal EMF.

Table 1. Resistor Thermal EMF

RESISTOR TYPE	THERMAL EMF/°C GRADIENT
Tin Oxide	>1mV/°C
Carbon Composition	~450μV/°C
Metal Film	~20μV/°C
Wire Wound Evenohm, Manganin	~2μV/°C

PACKAGE-INDUCED OFFSET VOLTAGE

Package-induced thermal EMF effects are another important source of errors. They arise at the junctions formed when wire or printed circuit traces contact a package lead. Like all the previously mentioned thermal EMF effects,

they are outside the LTC1151's offset nulling loop and cannot be cancelled. The input offset voltage specification of the LTC1151 is actually set by the package-induced warm-up drift rather than by the circuit itself. The thermal time constant ranges from 0.5 to 3 minutes, depending on package type.

ALIASING

Like all sampled data systems, the LTC1151 exhibits aliasing behavior at input frequencies near the sampling frequency. The LTC1151 includes a high frequency correction loop which minimizes this effect. As a result, aliasing is not a problem for many applications.

For a complete discussion of the correction circuitry and aliasing behavior, please refer to the LTC1051/LTC1053 data sheet.

LOW SUPPLY OPERATION

The minimum supply for proper operation of the LTC1151 is typically 4.0V ($\pm 2.0V$). In single supply applications, PSRR is guaranteed down to 4.7V ($\pm 2.35V$) to ensure proper operation at minimum TTL supply voltage of 4.75V.

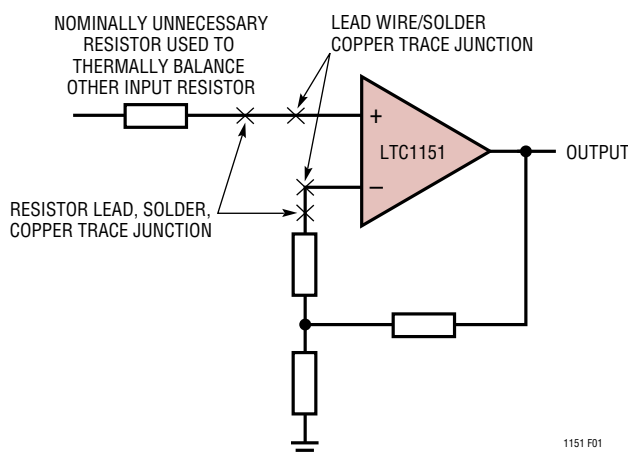
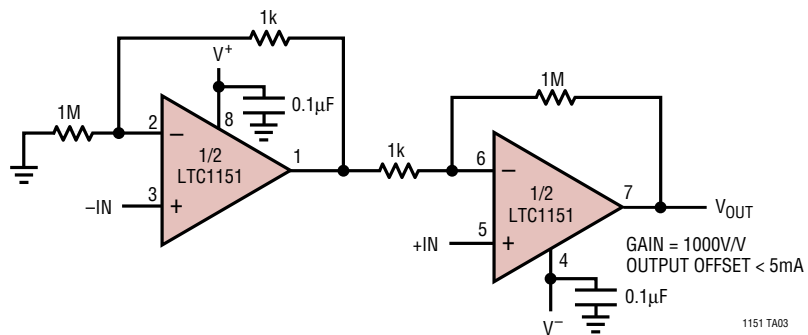

Figure 1. Extra Resistors Cancel Thermal EMF

TYPICAL APPLICATIONS

High Voltage Instrumentation Amplifier



PACKAGE DESCRIPTION

N8 Package
8-Lead PDIP (Narrow .300 Inch)
 (Reference LTC DWG # 05-08-1510)

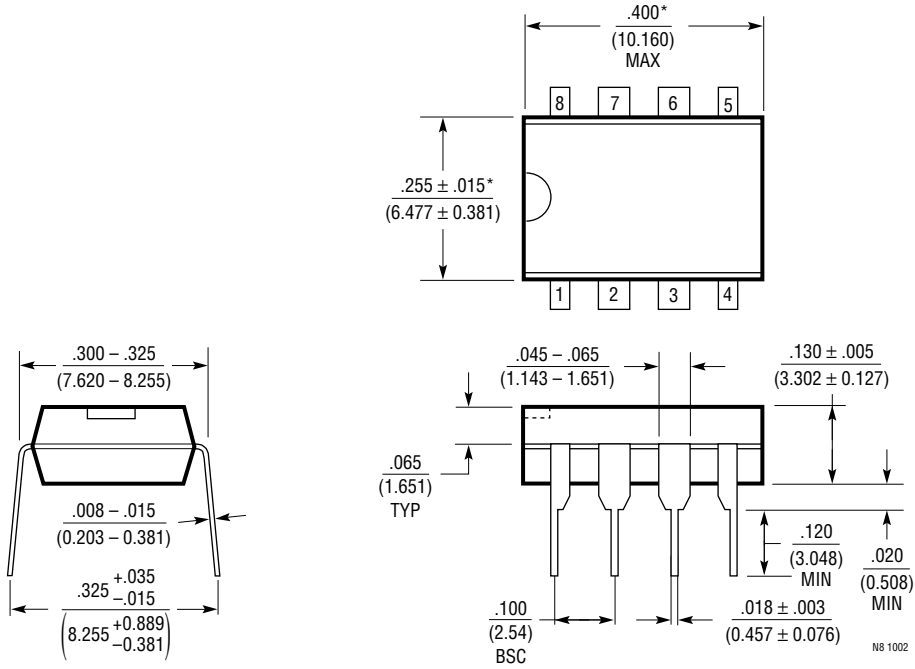

NOTE:
 1. DIMENSIONS ARE $\frac{\text{INCHES}}{\text{MILLIMETERS}}$
 *THESE DIMENSIONS DO NOT INCLUDE MOLD FLASH OR PROTRUSIONS.
 MOLD FLASH OR PROTRUSIONS SHALL NOT EXCEED .010 INCH (0.254mm)

PACKAGE DESCRIPTION

SW Package
16-Lead Plastic Small Outline (Wide .300 Inch)
 (Reference LTC DWG # 05-08-1620)

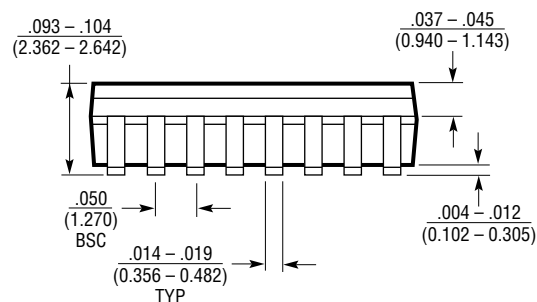
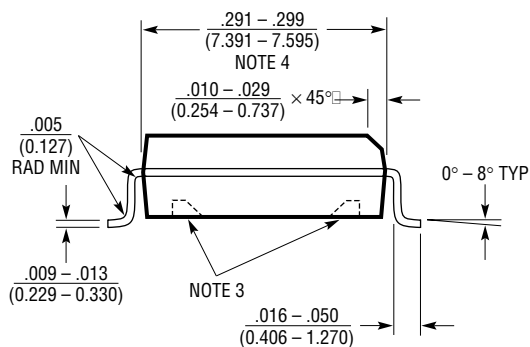
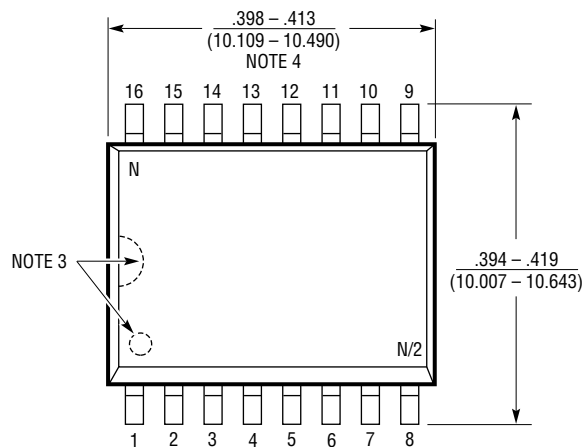
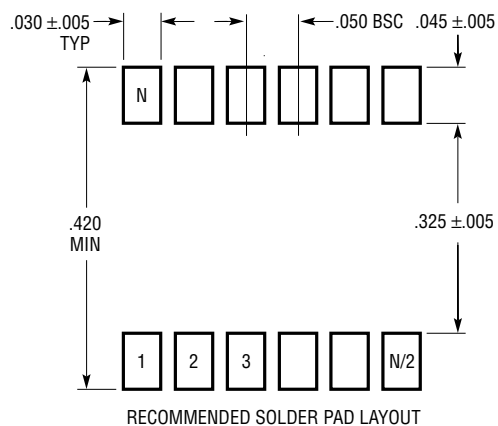

- NOTE:
1. DIMENSIONS IN $\frac{\text{INCHES}}{\text{(MILLIMETERS)}}$
 2. DRAWING NOT TO SCALE
 3. PIN 1 IDENT, NOTCH ON TOP AND CAVITIES ON THE BOTTOM OF PACKAGES ARE THE MANUFACTURING OPTIONS. THE PART MAY BE SUPPLIED WITH OR WITHOUT ANY OF THE OPTIONS
 4. THESE DIMENSIONS DO NOT INCLUDE MOLD FLASH OR PROTRUSIONS. MOLD FLASH OR PROTRUSIONS SHALL NOT EXCEED .006" (0.15mm)

S16 (WIDE) 0502

TYPICAL APPLICATIONS

Bridge Amplifier with Active Common-Mode Suppression

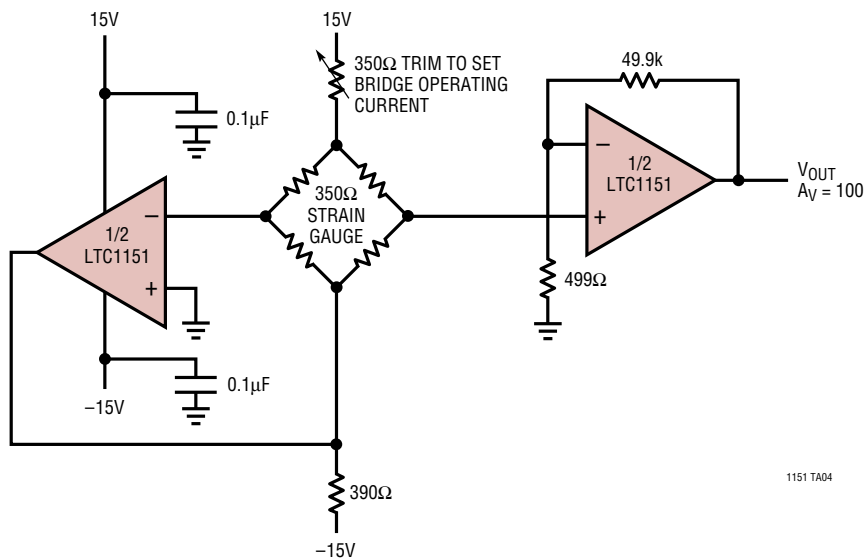

RELATED PARTS

PART NUMBER	DESCRIPTION	COMMENTS
LTC1049	Low Power Zero-Drift Op Amp	Low Supply Current 200μA
LTC1050	Precision Zero-Drift Op Amp	Single Supply Operation 4.75V to 16V, Noise Tested and Guaranteed
LTC1051/LTC1053	Precision Zero-Drift Op Amp	Dual/Quad
LTC1150	±15V Zero-Drift Op Amp	High Voltage Operation ±18V
LTC1152	Rail-to-Rail Input and Output Zero-Drift Op Amp	Single Zero-Drift Op Amp with Rail-to-Rail Input and Output and Shutdown
LT1677	Low Noise Rail-to-Rail Input and Output	$V_{OS} = 90\mu V$, $V_S = 2.7V$ to 44V Precision Op Amp
LT1884/LT1885	Rail-to-Rail Output Precision Op Amp	$V_{OS} = 50\mu V$, $I_B = 400pA$, $V_S = 2.7V$ to 40V
LTC2050/LTC2051/LTC2052	Single/Dual/Quad Zero-Drift Op Amp	Single Supply, 2.7V to ±5V, SOT-23/MS8/GN 16 Package
LTC2053	Zero-Drift Instrumentation Amp	Rail-to-Rail, MS8, 116dB, Two Resistors Set Gain
LTC2054/LTC2055	Single/Dual Zero-Drift Op Amp	150μA per Amplifier (Max), SOT-23/MS8 Package