

Precision, 100 μ A Gain Selectable Amplifier

FEATURES

- Pin Configurable as a Difference Amplifier, Inverting and Noninverting Amplifier
- **Difference Amplifier**
Gain Range 9 to 117
CMRR >80dB
- **Noninverting Amplifier**
Gain Range 0.008 to 118
- **Inverting Amplifier**
Gain Range -0.08 to -117
- **Gain Error: <0.05%**
- **Gain Drift: < 3ppm/°C**
- **Wide Supply Range: Single 2.7V to Split \pm 18V**
- **Micropower Operation: 100 μ A Supply**
- **Input Offset Voltage: 50 μ V (Max)**
- **Gain Bandwidth Product: 560kHz**
- **Rail-to-Rail Output**
- **Space Saving 10-Lead MSOP and DFN Packages**

APPLICATIONS

- Handheld Instrumentation
- Medical Instrumentation
- Strain Gauge Amplifiers
- Differential to Single-Ended Conversion

LT, LTC and LT are registered trademarks of Linear Technology Corporation. All other trademarks are the property of their respective owners. Patents Pending.

DESCRIPTION

The LT[®]1996 combines a precision operational amplifier with eight precision resistors to form a one-chip solution for accurately amplifying voltages. Gains from -117 to 118 with a gain accuracy of 0.05% can be achieved without any external components. The device is particularly well suited for use as a difference amplifier, where the excellent resistor matching results in a common mode rejection ratio of greater than 80dB.

The amplifier features a 50 μ V maximum input offset voltage and a gain bandwidth product of 560kHz. The device operates from any supply voltage from 2.7V to 36V and draws only 100 μ A supply current on a 5V supply. The output swings to within 40mV of either supply rail.

The internal resistors have excellent matching characteristics; variation is 0.05% over temperature with a guaranteed matching temperature coefficient of less than 3ppm/°C. The resistors are also extremely stable over voltage, exhibiting a nonlinearity of less than 10ppm.

The LT1996 is fully specified at 5V and \pm 15V supplies and from -40°C to 85°C. The device is available in space saving 10-lead MSOP and DFN packages. For an amplifier with selectable gains from -13 to 14, see the LT1991 data sheet.

TYPICAL APPLICATION

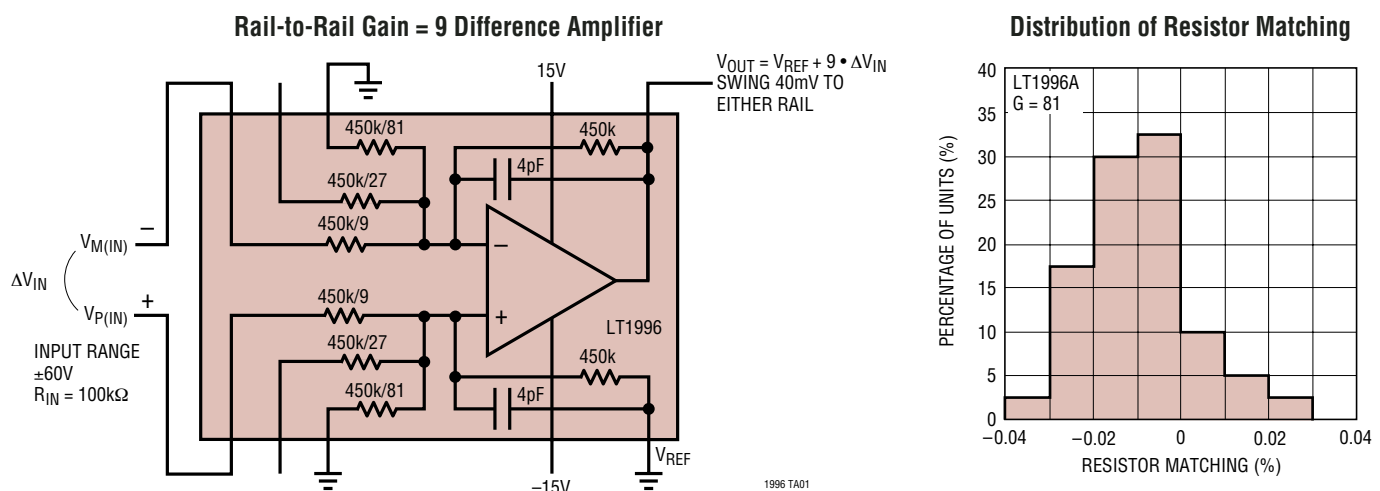

ABSOLUTE MAXIMUM RATINGS (Note 1)

Total Supply Voltage (V^+ to V^-)	40V	Maximum Junction Temperature	
Input Voltage (Pins P9/M9, Note 2)	$\pm 60V$	DD Package	125°C
Input Current		MS Package	150°C
(Pins P27/M27/P81/M81, Note 2)	$\pm 10mA$	Storage Temperature Range	
Output Short-Circuit Duration (Note 3)	Indefinite	DD Package	-65°C to 125°C
Operating Temperature Range (Note 4) ...	-40°C to 85°C	MS Package	-65°C to 150°C
Specified Temperature Range (Note 5)	-40°C to 85°C	MSOP-Lead Temperature (Soldering, 10 sec).....	300°C

PACKAGE/ORDER INFORMATION

<p>DD PACKAGE 10-LEAD (3mm x 3mm) PLASTIC DFN $T_{JMAX} = 125^\circ C$, $\theta_{JA} = 160^\circ C/W$ UNDERSIDE METAL CONNECTED TO V_{EE} (PCB CONNECTION OPTIONAL)</p>	ORDER PART NUMBER	<p>MS PACKAGE 10-LEAD PLASTIC MSOP $T_{JMAX} = 150^\circ C$, $\theta_{JA} = 230^\circ C/W$</p>	ORDER PART NUMBER
	LT1996CDD LT1996IDD LT1996ACDD LT1996AIDD		LT1996CMS LT1996IMS LT1996ACMS LT1996AIMS
	DD PART MARKING*		MS PART MARKING*
	LBPC		LTBPB

*Temperature and electrical grades are identified by a label on the shipping container. Consult LTC Marketing for parts specified with wider operating temperature ranges.

ELECTRICAL CHARACTERISTICS

The ● denotes the specifications which apply over the full operating temperature range, otherwise specifications are at $T_A = 25^\circ C$. Difference amplifier configuration, $V_S = 5V, 0V$ or $\pm 15V$; $V_{CM} = V_{REF} =$ half supply, unless otherwise noted.

SYMBOL	PARAMETER	CONDITIONS	MIN	TYP	MAX	UNITS	
ΔG	Gain Error	$V_S = \pm 15V$, $V_{OUT} = \pm 10V$; $R_L = 10k$					
		$G = 81$; LT1996AMS	●	± 0.02	± 0.05	%	
		$G = 27$; LT1996AMS	●	± 0.03	± 0.06	%	
		$G = 9$; LT1996AMS	●	± 0.03	± 0.07	%	
		$G = 81$; LT1996ADD	●	± 0.02	± 0.05	%	
		$G = 27$; LT1996ADD	●	± 0.02	± 0.07	%	
		$G = 9$; LT1996ADD	●	± 0.03	± 0.08	%	
		$G = 81$; LT1996	●	± 0.04	± 0.12	%	
		$G = 27$; LT1996	●	± 0.04	± 0.12	%	
$G = 9$; LT1996	●	± 0.04	± 0.12	%			
GNL	Gain Nonlinearity	$V_S = \pm 15V$; $V_{OUT} = \pm 10V$; $R_L = 10k$; $G = 9$	●	1	10	ppm	
$\Delta G/\Delta T$	Gain Drift vs Temperature (Note 6)	$V_S = \pm 15V$; $V_{OUT} = \pm 10V$; $R_L = 10k$	●	0.3	3	ppm/ $^\circ C$	
CMRR	Common Mode Rejection Ratio, Referred to Inputs (RTI)	$V_S = \pm 15V$; $G = 9$; $V_{CM} = \pm 15.3V$					
		LT1996AMS	●	80	100	dB	
		LT1996ADD	●	80	100	dB	
		LT1996	●	70	100	dB	
		$V_S = \pm 15V$; $G = 27$; $V_{CM} = -14.5V$ to $14.3V$					
		LT1996AMS	●	95	105	dB	
LT1996ADD	●	90	105	dB			
LT1996	●	75	105	dB			

ELECTRICAL CHARACTERISTICS The ● denotes the specifications which apply over the full operating temperature range, otherwise specifications are at $T_A = 25^\circ\text{C}$. Difference amplifier configuration, $V_S = 5\text{V}$, 0V or $\pm 15\text{V}$; $V_{CM} = V_{REF} = \text{half supply}$, unless otherwise noted.

SYMBOL	PARAMETER	CONDITIONS	MIN	TYP	MAX	UNITS	
CMRR	Common Mode Rejection Ratio (RTI)	$V_S = \pm 15\text{V}$; $G = 81$; $V_{CM} = -14.1\text{V}$ to 13.9V LT1996AMS	●	105	120	dB	
		LT1996ADD	●	100	120	dB	
		LT1996	●	85	120	dB	
V_{CM}	Input Voltage Range (Note 7)	P9/M9 Inputs $V_S = \pm 15\text{V}$; $V_{REF} = 0\text{V}$	●	-15.5	15.3	V	
		$V_S = 5\text{V}$, 0V ; $V_{REF} = 2.5\text{V}$	●	0.84	3.94	V	
		$V_S = 3\text{V}$, 0V ; $V_{REF} = 1.25\text{V}$	●	0.98	1.86	V	
		P9/M9 Inputs, P81/M81 Connected to REF $V_S = \pm 15\text{V}$; $V_{REF} = 0\text{V}$	●	-60	60	V	
		$V_S = 5\text{V}$, 0V ; $V_{REF} = 2.5\text{V}$	●	-12.6	15.6	V	
		$V_S = 3\text{V}$, 0V ; $V_{REF} = 1.25\text{V}$	●	-1.25	6.8	V	
		P27/M27 Inputs $V_S = \pm 15\text{V}$; $V_{REF} = 0\text{V}$	●	-14.5	14.3	V	
		$V_S = 5\text{V}$, 0V ; $V_{REF} = 2.5\text{V}$	●	0.95	3.84	V	
		$V_S = 3\text{V}$, 0V ; $V_{REF} = 1.25\text{V}$	●	1	1.82	V	
		P81/M81 Inputs $V_S = \pm 15\text{V}$; $V_{REF} = 0\text{V}$	●	-14.1	13.9	V	
		$V_S = 5\text{V}$, 0V ; $V_{REF} = 2.5\text{V}$	●	0.99	3.81	V	
		$V_S = 3\text{V}$, 0V ; $V_{REF} = 1.25\text{V}$	●	1	1.8	V	
V_{OS}	Op Amp Offset Voltage (Note 8)	LT1996AMS, $V_S = 5\text{V}$, 0V	●		15 50 135	μV μV	
		LT1996AMS, $V_S = \pm 15\text{V}$	●		15 80 160	μV μV	
		LT1996MS	●		25 100 200	μV μV	
		LT1996DD	●		25 150 250	μV μV	
$\Delta V_{OS}/\Delta T$	Op Amp Offset Voltage Drift (Note 6)		●	0.3	1	$\mu\text{V}/^\circ\text{C}$	
I_B	Op Amp Input Bias Current		●	2.5	5	nA	
			●		7.5	nA	
I_{OS}	Op Amp Input Offset Current	LT1996A	●	50	500	pA	
		LT1996	●	50	1000	pA	
e_n	Op Amp Input Noise Voltage	0.01Hz to 1Hz		0.35		μV_{P-P}	
		0.01Hz to 1Hz		0.07		μV_{RMS}	
		0.1Hz to 10Hz		0.25		μV_{P-P}	
		0.1Hz to 10Hz		0.05		μV_{RMS}	
e_n	Input Noise Voltage Density (Includes Resistor Noise)	$G = 9$; $f = 1\text{kHz}$		46		$\text{nV}/\sqrt{\text{Hz}}$	
		$G = 117$; $f = 1\text{kHz}$		18		$\text{nV}/\sqrt{\text{Hz}}$	
R_{IN}	Input Impedance (Note 10)	P9 (M9 = Ground)	●	350	500	650	k Ω
		P27 (M27 = Ground)	●	326.9	467	607.1	k Ω
		P81 (M81 = Ground)	●	319.2	456	592.8	k Ω
		M9 (P9 = Ground)	●	35	50	65	k Ω
		M27 (P27 = Ground)	●	11.69	16.7	21.71	k Ω
		M81 (P81 = Ground)	●	3.85	5.5	7.15	k Ω

ELECTRICAL CHARACTERISTICS The ● denotes the specifications which apply over the full operating temperature range, otherwise specifications are at $T_A = 25^\circ\text{C}$. Difference amplifier configuration, $V_S = 5\text{V}, 0\text{V}$ or $\pm 15\text{V}$; $V_{CM} = V_{REF} = \text{half supply}$, unless otherwise noted.

SYMBOL	PARAMETER	CONDITIONS	MIN	TYP	MAX	UNITS	
ΔR	Resistor Matching (Note 9)	G = 81; LT1996AMS	●	± 0.02	± 0.05	%	
		G = 27; LT1996AMS	●	± 0.03	± 0.06	%	
		G = 9; LT1996AMS	●	± 0.03	± 0.07	%	
		G = 81; LT1996ADD	●	± 0.02	± 0.05	%	
		G = 27; LT1996ADD	●	± 0.02	± 0.07	%	
		G = 9; LT1996ADD	●	± 0.03	± 0.08	%	
		G = 81; LT1996	●	± 0.04	± 0.12	%	
		G = 27; LT1996	●	± 0.04	± 0.12	%	
		G = 9; LT1996	●	± 0.04	± 0.12	%	
$\Delta R/\Delta T$	Resistor Temperature Coefficient (Note 6)	Resistor Matching	●	0.3	3	ppm/ $^\circ\text{C}$	
		Absolute Value	●	-30		ppm/ $^\circ\text{C}$	
PSRR	Power Supply Rejection Ratio	$V_S = \pm 1.35\text{V}$ to $\pm 18\text{V}$ (Note 8)	●	105	135	dB	
	Minimum Supply Voltage		●	2.4	2.7	V	
V_{OUT}	Output Voltage Swing (to Either Rail)	No Load					
		$V_S = 5\text{V}, 0\text{V}$		40	55	mV	
		$V_S = 5\text{V}, 0\text{V}$	●		65	mV	
		$V_S = \pm 15\text{V}$	●		110	mV	
		1mA Load					
		$V_S = 5\text{V}, 0\text{V}$		150	225	mV	
$V_S = 5\text{V}, 0\text{V}$	●			275	mV		
$V_S = \pm 15\text{V}$	●			300	mV		
I_{SC}	Output Short-Circuit Current (Sourcing)	Drive Output Positive; Short Output to Ground	●	8 4	12	mA mA	
	Output Short-Circuit Current (Sinking)	Drive Output Negative; Short Output to V_S or Midsupply	●	8 4	21	mA mA	
BW	-3dB Bandwidth	G = 9		38		kHz	
		G = 27		17		kHz	
		G = 81		7		kHz	
GBWP	Op Amp Gain Bandwidth Product	f = 10kHz		560		kHz	
t_r, t_f	Rise Time, Fall Time	G = 9; 0.1V Step; 10% to 90%		8		μs	
		G = 81; 0.1V Step; 10% to 90%		40		μs	
t_S	Settling Time to 0.01%	G = 9; $V_S = 5\text{V}, 0\text{V}$; 2V Step		85		μs	
		G = 9; $V_S = 5\text{V}, 0\text{V}$; -2V Step		85		μs	
		G = 9; $V_S = \pm 15\text{V}$; 10V Step		110		μs	
		G = 9; $V_S = \pm 15\text{V}$; -10V Step		110		μs	
SR	Slew Rate	$V_S = 5\text{V}, 0\text{V}$; $V_{OUT} = 1\text{V}$ to 4V	●	0.06	0.12	$\text{V}/\mu\text{s}$	
		$V_S = \pm 15\text{V}$; $V_{OUT} = \pm 10\text{V}$	●	0.08	0.12	$\text{V}/\mu\text{s}$	
I_S	Supply Current	$V_S = 5\text{V}, 0\text{V}$	●	100	110	μA	
					150	μA	
		$V_S = \pm 15\text{V}$	●	130	160	μA	
				210	μA		

Note 1: Absolute Maximum Ratings are those beyond which the life of the device may be impaired.

Note 2: The P27/M27 and P81/M81 inputs are protected by ESD diodes to the supply rails. If one of these four inputs goes outside the rails, the input current should be limited to less than 10mA. The P9/M9 inputs can

withstand $\pm 60\text{V}$ if P81/M81 are grounded and $V_S = \pm 15\text{V}$ (see Applications Information section about "High Voltage CM Difference Amplifiers").

Note 3: A heat sink may be required to keep the junction temperature below absolute maximum ratings.

ELECTRICAL CHARACTERISTICS

Note 4: Both the LT1996C and LT1996I are guaranteed functional over the -40°C to 85°C temperature range.

Note 5: The LT1996C is guaranteed to meet the specified performance from 0°C to 70°C and is designed, characterized and expected to meet specified performance from -40°C to 85°C but is not tested or QA sampled at these temperatures. The LT1996I is guaranteed to meet specified performance from -40°C to 85°C .

Note 6: This parameter is not 100% tested.

Note 7: Input voltage range is guaranteed by the CMRR test at $V_S = \pm 15\text{V}$. For the other voltages, this parameter is guaranteed by design and through correlation with the $\pm 15\text{V}$ test. See the Applications Information section to

determine the valid input voltage range under various operating conditions.

Note 8: Offset voltage, offset voltage drift and PSRR are defined as referred to the internal op amp. You can calculate output offset as follows. In the case of balanced source resistance, $V_{OS, OUT} = V_{OS} \cdot \text{Noise Gain} + I_{OS} \cdot 450\text{k} + I_B \cdot 450\text{k} \cdot (1 - R_P/R_N)$ where R_P and R_N are the total resistance at the op amp positive and negative terminal respectively.

Note 9: Resistors connected to the minus inputs. Resistor matching is not tested directly, but is guaranteed by the gain error test.

Note 10: Input impedance is tested by a combination of direct measurements and correlation to the CMRR and gain error tests.

TYPICAL PERFORMANCE CHARACTERISTICS (Difference Amplifier Configuration)

Supply Current vs Supply Voltage

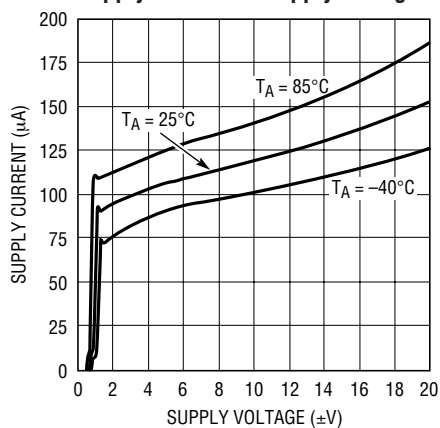

1996 G01

Output Voltage Swing vs Temperature

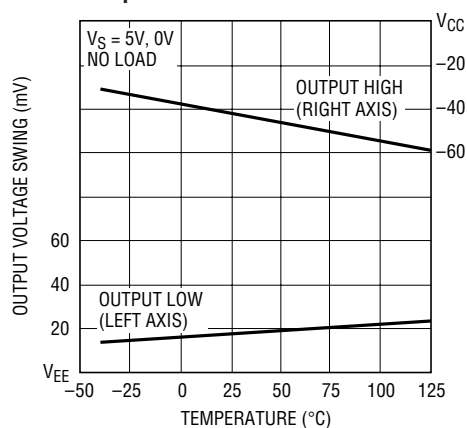

1996 G02

Output Voltage Swing vs Load Current (Output Low)

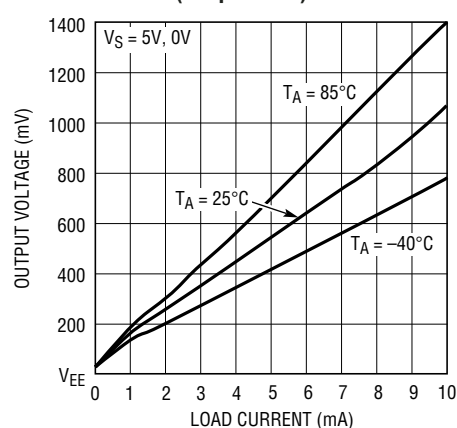

1996 G03

Output Voltage Swing vs Load Current (Output High)

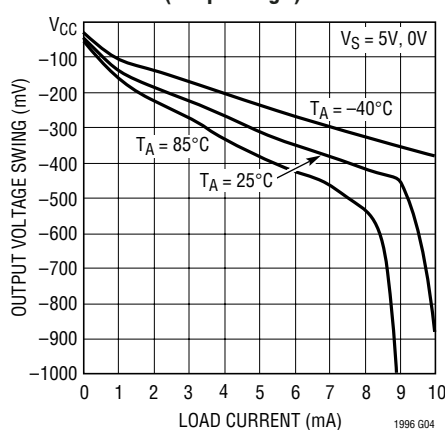

1996 G04

Output Short-Circuit Current vs Temperature

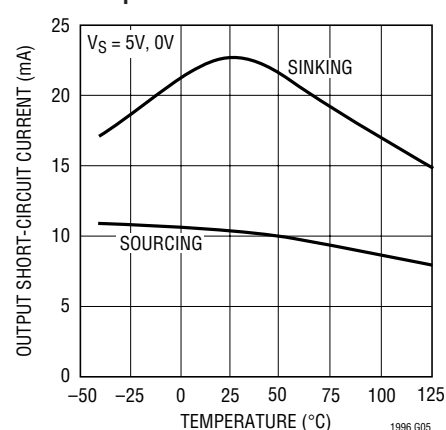

1996 G05

Input Offset Voltage vs Difference Gain

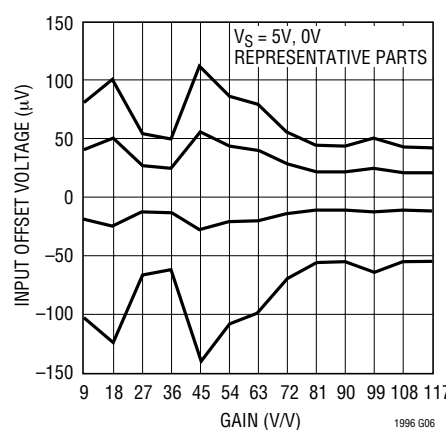

1996 G06

TYPICAL PERFORMANCE CHARACTERISTICS (Difference Amplifier Configuration)

Output Offset Voltage vs Difference Gain

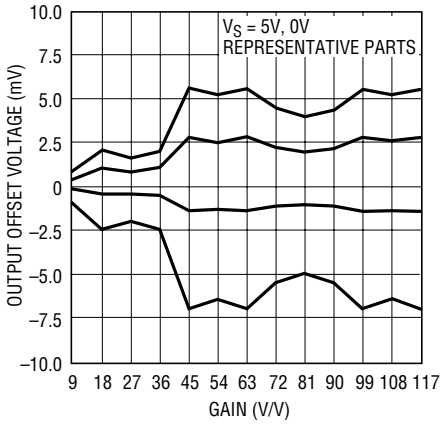

1996 G07

Gain Error vs Load Current

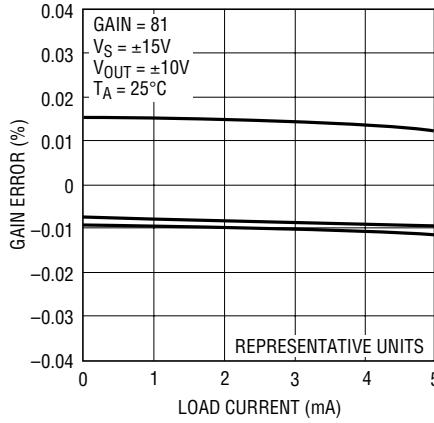

1996 G08

Slew Rate vs Temperature

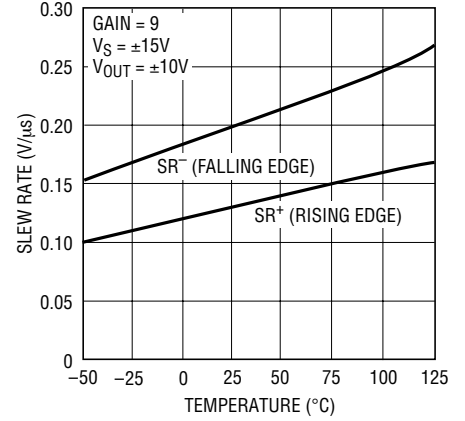

1996 G09

Bandwidth vs Gain

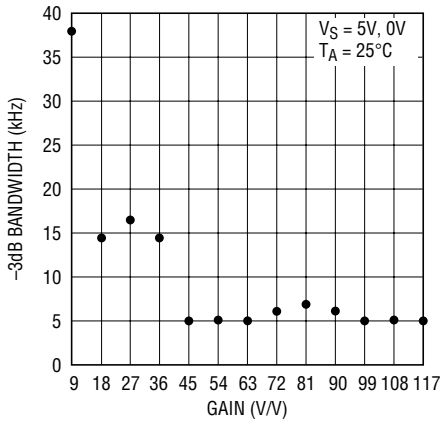

1996 G10

CMRR vs Frequency

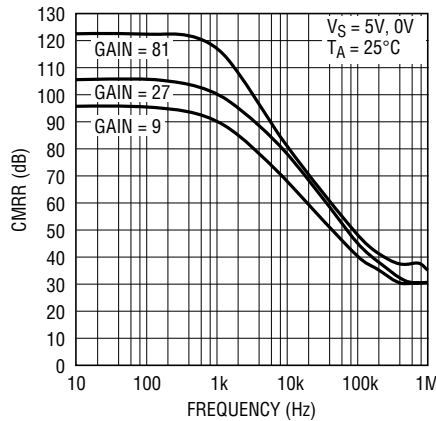

1996 G11

PSRR vs Frequency

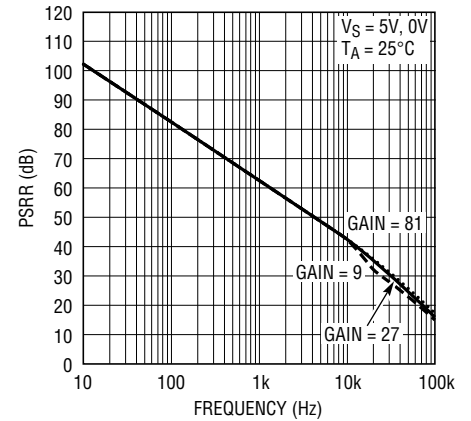

1996 G12

Output Impedance vs Frequency

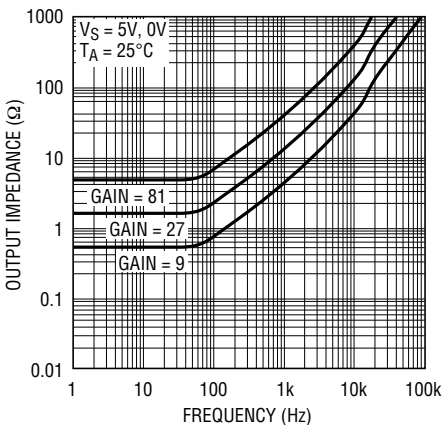

1996 G13

CMRR vs Temperature

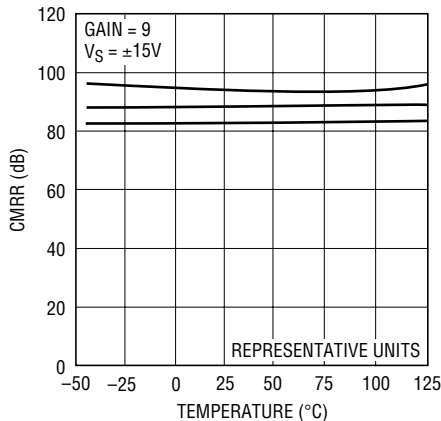

1996 G14

Gain Error vs Temperature

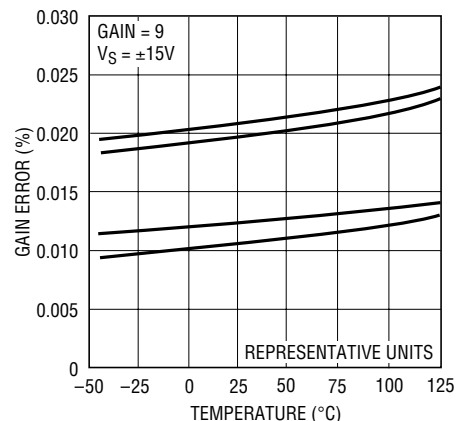

1996 G15

TYPICAL PERFORMANCE CHARACTERISTICS (Difference Amplifier Configuration)

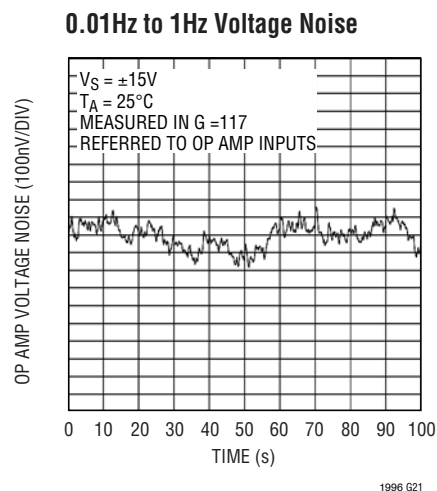
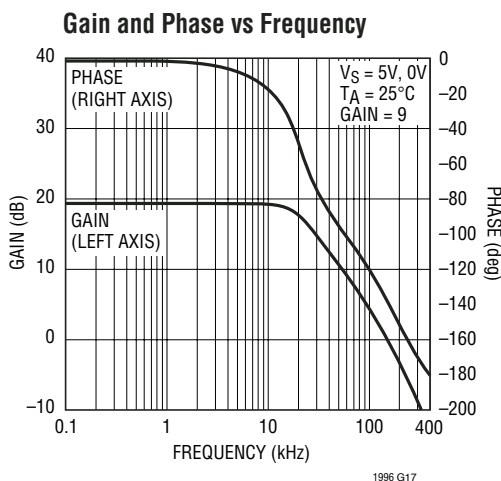
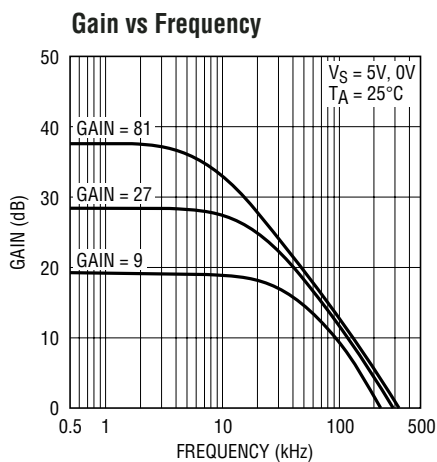

Small Signal Transient Response, Gain = 9

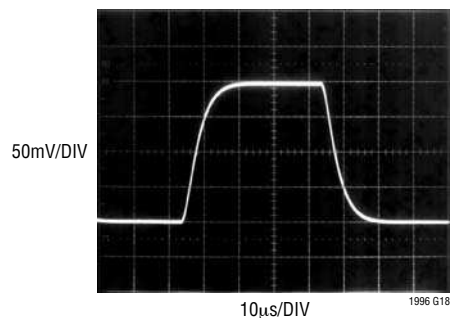

Small Signal Transient Response, Gain = 27

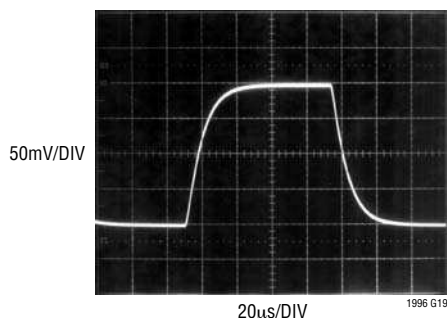

Small Signal Transient Response, Gain = 81

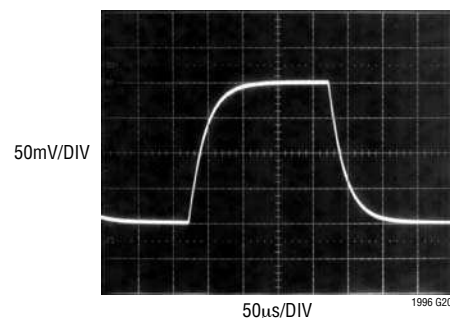

PIN FUNCTIONS (Difference Amplifier Configuration)

P9 (Pin 1): Noninverting Gain-of-9 input. Connects a 50k internal resistor to the op amp's noninverting input.

P27 (Pin 2): Noninverting Gain-of-27 input. Connects a (50k/3) internal resistor to the op amp's noninverting input.

P81 (Pin 3): Noninverting Gain-of-81 input. Connects a (50k/9) internal resistor to the op amp's noninverting input.

VEE (Pin 4): Negative Power Supply. Can be either ground (in single supply applications), or a negative voltage (in split supply applications).

REF (Pin 5): Reference Input. Sets the output level when difference between inputs is zero. Connects a 450k internal

resistor to the op amp's noninverting input.

OUT (Pin 6): Output. $V_{OUT} = V_{REF} + 9 \cdot (V_{P1} - V_{M1}) + 27 \cdot (V_{P3} - V_{M3}) + 81 \cdot (V_{P9} - V_{M9})$.

VCC (Pin 7): Positive Power Supply. Can be anything from 2.7V to 36V above the VEE voltage.

M81 (Pin 8): Inverting Gain-of-81 input. Connects a (50k/9) internal resistor to the op amp's inverting input.

M27 (Pin 9): Inverting Gain-of-27 input. Connects a (50k/3) internal resistor to the op amp's inverting input.

M9 (Pin 10): Inverting Gain-of-9 input. Connects a 50k internal resistor to the op amp's inverting input.

BLOCK DIAGRAM

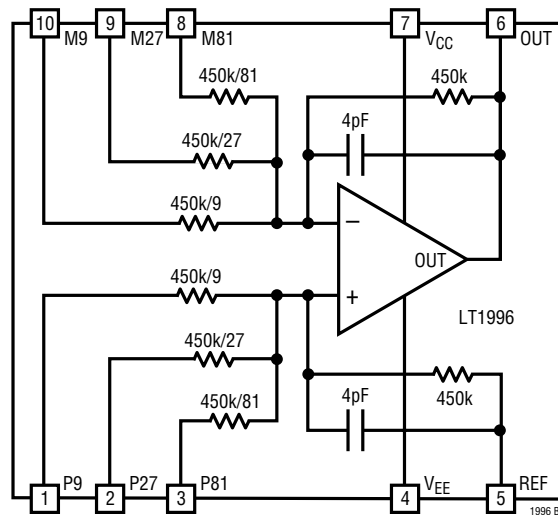

APPLICATIONS INFORMATION

Introduction

The LT1996 may be the last op amp you ever have to stock. Because it provides you with several precision matched resistors, you can easily configure it into several different classical gain circuits without adding external components. The several pages of simple circuits in this data sheet demonstrate just how easy the LT1996 is to use. It can be configured into difference amplifiers, as well as into inverting and noninverting single ended amplifiers. The fact that the resistors and op amp are provided together in such a small package will often save you board space and reduce complexity for easy probing.

The Op Amp

The op amp internal to the LT1996 is a precision device with 15 μ V typical offset voltage and 3nA input bias current. The input offset current is extremely low, so matching the source resistance seen by the op amp inputs will provide for the best output accuracy. The op amp inputs are not rail-to-rail, but extend to within 1.2V of V_{CC} and 1V

of V_{EE} . For many configurations though, the chip inputs will function rail-to-rail because of effective attenuation to the +input. The output is truly rail-to-rail, getting to within 40mV of the supply rails. The gain bandwidth product of the op amp is about 560kHz. In noise gains of 2 or more, it is stable into capacitive loads up to 500pF. In noise gains below 2, it is stable into capacitive loads up to 100pF.

The Resistors

The resistors internal to the LT1996 are very well matched SiChrome based elements protected with barrier metal. Although their absolute tolerance is fairly poor ($\pm 30\%$), their matching is to within 0.05%. This allows the chip to achieve a CMRR of 80dB, and gain errors within 0.05%. The resistor values are (450k/9), (450k/27), (450k/81) and 450k, connected to each of the inputs. The resistors have power limitations of 1watt for the 450k and (450k/81) resistors, 0.3watt for the (450k/27) resistors and 0.5watt for the (450k/9) resistors; however, in practice, power dissipation will be limited well below these values by the

APPLICATIONS INFORMATION

maximum voltage allowed on the input and REF pins. The 50k resistors connected to the M9 and P9 inputs are isolated from the substrate, and can therefore be taken beyond the supply voltages. The naming of the pins “P9,” “P27,” “P81,” etc., is based on their admittances relative to the feedback and REF admittances. Because it has 9 times the admittance, the voltage applied to the P9 input has 9 times the effect of the voltage applied to the REF input.

Bandwidth

The bandwidth of the LT1996 will depend on the gain you select (or more accurately the noise gain resulting from the gain you select). In the lowest configurable gain of 1, the -3dB bandwidth is limited to 450kHz, with peaking of about 2dB at 280kHz. In the highest configurable gains, bandwidth is limited to 5kHz.

Input Noise

The LT1996 input noise is comprised of the Johnson noise of the internal resistors ($\sqrt{4kTR}$), and the input voltage noise of the op amp. Paralleling all four resistors to the +input gives a $3.8\text{k}\Omega$ resistance, for $8\text{nV}/\sqrt{\text{Hz}}$ of voltage noise. The equivalent network on the $-$ input gives another $8\text{nV}/\sqrt{\text{Hz}}$, and the op amp $14\text{nV}/\sqrt{\text{Hz}}$. Taking their RMS sum gives a total $18\text{nV}/\sqrt{\text{Hz}}$ input referred noise floor. Output noise depends on configuration and noise gain.

Input Resistance

The LT1996 input resistances vary with configuration, but once configured are apparent on inspection. Note that resistors connected to the op amp's $-$ input are looking into a virtual ground, so they simply parallel. Any feedback resistance around the op amp does not contribute to input resistance. Resistors connected to the op amp's +input are looking into a high impedance, so they add as parallel or series depending on how they are connected, and whether or not some of them are grounded. The op amp +input itself presents a very high $\text{G}\Omega$ impedance. In the

classical noninverting op amp configuration, the LT1996 presents the high input impedance of the op amp, as is usual for the noninverting case.

Common Mode Input Voltage Range

The LT1996 valid common mode input range is limited by three factors:

1. Maximum allowed voltage on the pins
2. The input voltage range of the internal op amp
3. Valid output voltage

The maximum voltage allowed on the P27, M27, P81 and M81 inputs includes the positive and negative supply plus a diode drop. These pins should not be driven more than a diode drop outside of the supply rails. This is because they are connected through diodes to internal manufacturing post-package trim circuitry, and through a substrate diode to V_{EE} . If more than 10mA is allowed to flow through these pins, there is a risk that the LT1996 will be detrimmed or damaged. The P9 and M9 inputs do not have clamp diodes or substrate diodes or trim circuitry and can be taken well outside the supply rails. The maximum allowed voltage on the P9 and M9 pins is $\pm 60\text{V}$.

The input voltage range of the internal op amp extends to within 1.2V of V_{CC} and 1V of V_{EE} . The voltage at which the op amp inputs common mode is determined by the voltage at the op amp's +input, and this is determined by the voltages on pins P9, P27, P81 and REF. (See “Calculating Input Voltage Range” section.) This is true provided that the op amp is functioning and feedback is maintaining the inputs at the same voltage, which brings us to the third requirement.

For valid circuit function, the op amp output must not be clipped. The output will clip if the input signals are attempting to force it to within 40mV of its supply voltages. This usually happens due to too large a signal level, but it can also occur with zero input differential and must therefore be included as an example of a common mode problem.

APPLICATIONS INFORMATION

Consider Figure 1. This shows the LT1996 configured as a gain of 117 difference amplifier on a single supply with

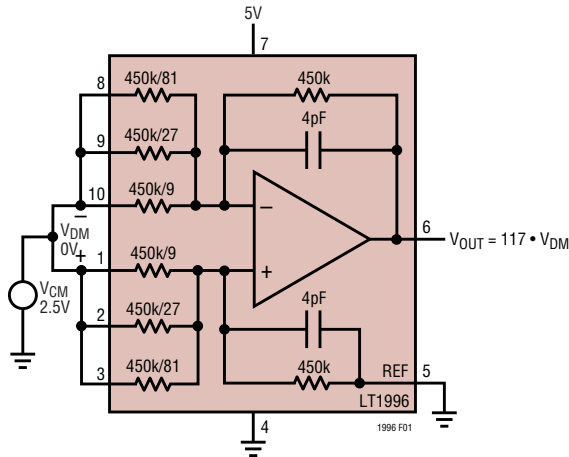

Figure 1. Difference Amplifier Cannot Produce 0V on a Single Supply. Provide a Negative Supply, or Raise Pin 5, or Provide 400µV of V_{DM}

the output REF connected to ground. This is a great circuit, but it does not support V_{DM} = 0V at any common mode because the output clips into ground while trying to produce 0V_{OUT}. It can be fixed simply by declaring the valid input differential range not to extend below +0.4mV, or by elevating the REF pin above 40mV, or by providing a negative supply.

Calculating Input Voltage Range

Figure 2 shows the LT1996 in the generalized case of a difference amplifier, with the inputs shorted for the common mode calculation. The values of R_F and R_G are dictated by how the P inputs and REF pin are connected. By superposition we can write:

$$V_{INT} = V_{EXT} \cdot (R_F / (R_F + R_G)) + V_{REF} \cdot (R_G / (R_F + R_G))$$

Or, solving for V_{EXT}:

$$V_{EXT} = V_{INT} \cdot (1 + R_G / R_F) - V_{REF} \cdot R_G / R_F$$

But valid V_{INT} voltages are limited to V_{CC} - 1.2V and V_{EE} + 1V, so:

$$\text{MAX } V_{EXT} = (V_{CC} - 1.2) \cdot (1 + R_G / R_F) - V_{REF} \cdot R_G / R_F$$

and:

$$\text{MIN } V_{EXT} = (V_{EE} + 1) \cdot (1 + R_G / R_F) - V_{REF} \cdot R_G / R_F$$

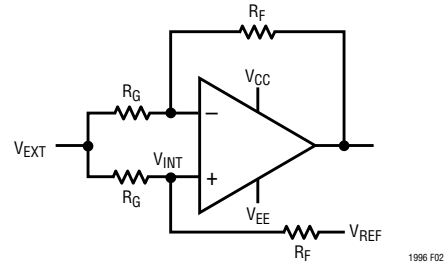

Figure 2. Calculating CM Input Voltage Range

These two voltages represent the high and low extremes of the common mode input range, if the other limits have not already been exceeded (1 and 3, above). In most cases, the inverting inputs M9 through M81 can be taken further than these two extremes because doing this does not move the op amp input common mode. To calculate the limit on this additional range, see Figure 3. Note that, with

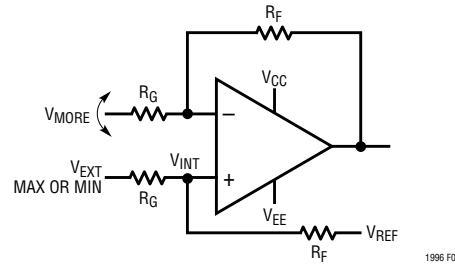

Figure 3. Calculating Additional Voltage Range of Inverting Inputs

V_{MORE} = 0, the op amp output is at V_{REF}. From the max V_{EXT} (the high cm limit), as V_{MORE} goes positive, the op amp output will go more negative from V_{REF} by the amount V_{MORE} • R_F/R_G, so:

$$V_{OUT} = V_{REF} - V_{MORE} \cdot R_F / R_G$$

Or:

$$V_{MORE} = (V_{REF} - V_{OUT}) \cdot R_G / R_F$$

The most negative that V_{OUT} can go is V_{EE} + 0.04V, so:

$$\text{Max } V_{MORE} = (V_{REF} - V_{EE} - 0.04V) \cdot R_G / R_F$$

(should be positive)

The situation where this function is negative, and therefore problematic, when V_{REF} = 0 and V_{EE} = 0, has already been dealt with in Figure 1. The strength of the equation is demonstrated in that it provides the three solutions

APPLICATIONS INFORMATION

suggested in Figure 1: raise V_{REF} , lower V_{EE} , or provide some negative V_{MORE} .

Likewise, from the lower common mode extreme, making the negative input more negative will raise the output voltage, limited by $V_{CC} - 0.04V$.

$$\text{MIN } V_{MORE} = (V_{REF} - V_{CC} + 0.04V) \cdot R_G/R_F$$

(should be negative)

Again, the additional input range calculated here is only available provided the other remaining constraint is not violated, the maximum voltage allowed on the pin.

The Classical Noninverting Amplifier: High Input Z

Perhaps the most common op amp configuration is the noninverting amplifier. Figure 4 shows the textbook

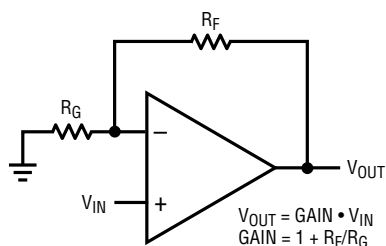

CLASSICAL NONINVERTING OP AMP CONFIGURATION. YOU PROVIDE THE RESISTORS.

$$V_{OUT} = \text{GAIN} \cdot V_{IN}$$

$$\text{GAIN} = 1 + R_F/R_G$$

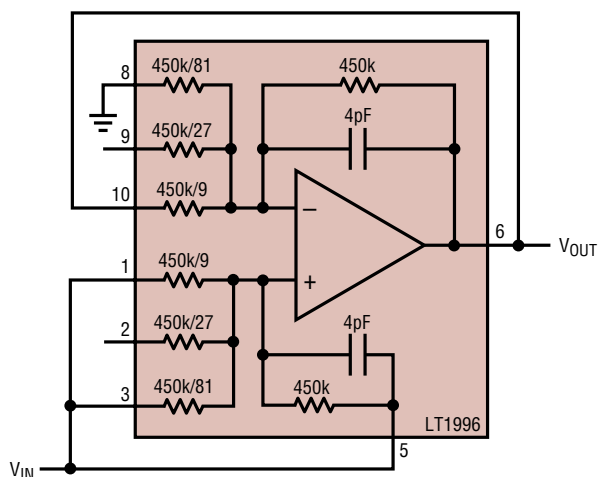

CLASSICAL NONINVERTING OP AMP CONFIGURATION IMPLEMENTED WITH LT1991. $R_F = 45k$, $R_G = 5.6k$, GAIN = 9.1.

GAIN IS ACHIEVED BY GROUNDING, FLOATING OR FEEDING BACK THE AVAILABLE RESISTORS TO ARRIVE AT DESIRED R_F AND R_G .

WE PROVIDE YOU WITH <0.1% RESISTORS.

1996 F04

representation of the circuit on the top. The LT1996 is shown on the bottom configured in a precision gain of 9.1. One of the benefits of the noninverting op amp configuration is that the input impedance is extremely high. The LT1996 maintains this benefit. Given the finite number of available feedback resistors in the LT1996, the number of gain configurations is also finite. The complete list of such Hi-Z input noninverting gain configurations is shown in Table 1. Many of these are also represented in Figure 5 in schematic form. Note that the P-side resistor inputs have been connected so as to match the source impedance seen by the internal op amp inputs. Note also that gain and noise gain are identical, for optimal precision.

Table 1. Configuring the M Pins for Simple Noninverting Gains. The P Inputs are driven as shown in the examples on the next page

Gain	M81, M27, M9 Connection		
	M81	M27	M9
1	Output	Output	Output
1.08	Output	Output	Grounded
1.11	Output	Float	Grounded
1.30	Output	Grounded	Output
1.32	Float	Output	Grounded
1.33	Output	Grounded	Float
1.44	Output	Grounded	Grounded
3.19	Grounded	Output	Output
3.7	Float	Grounded	Output
3.89	Grounded	Output	Float
4.21	Grounded	Output	Grounded
9.1	Grounded	Float	Output
10	Float	Float	Grounded
11.8	Grounded	Grounded	Output
28	Float	Grounded	Float
37	Float	Grounded	Grounded
82	Grounded	Float	Float
91	Grounded	Float	Grounded
109	Grounded	Grounded	Float
118	Grounded	Grounded	Grounded

Figure 4. The LT1996 as a Classical Noninverting Op Amp

APPLICATIONS INFORMATION

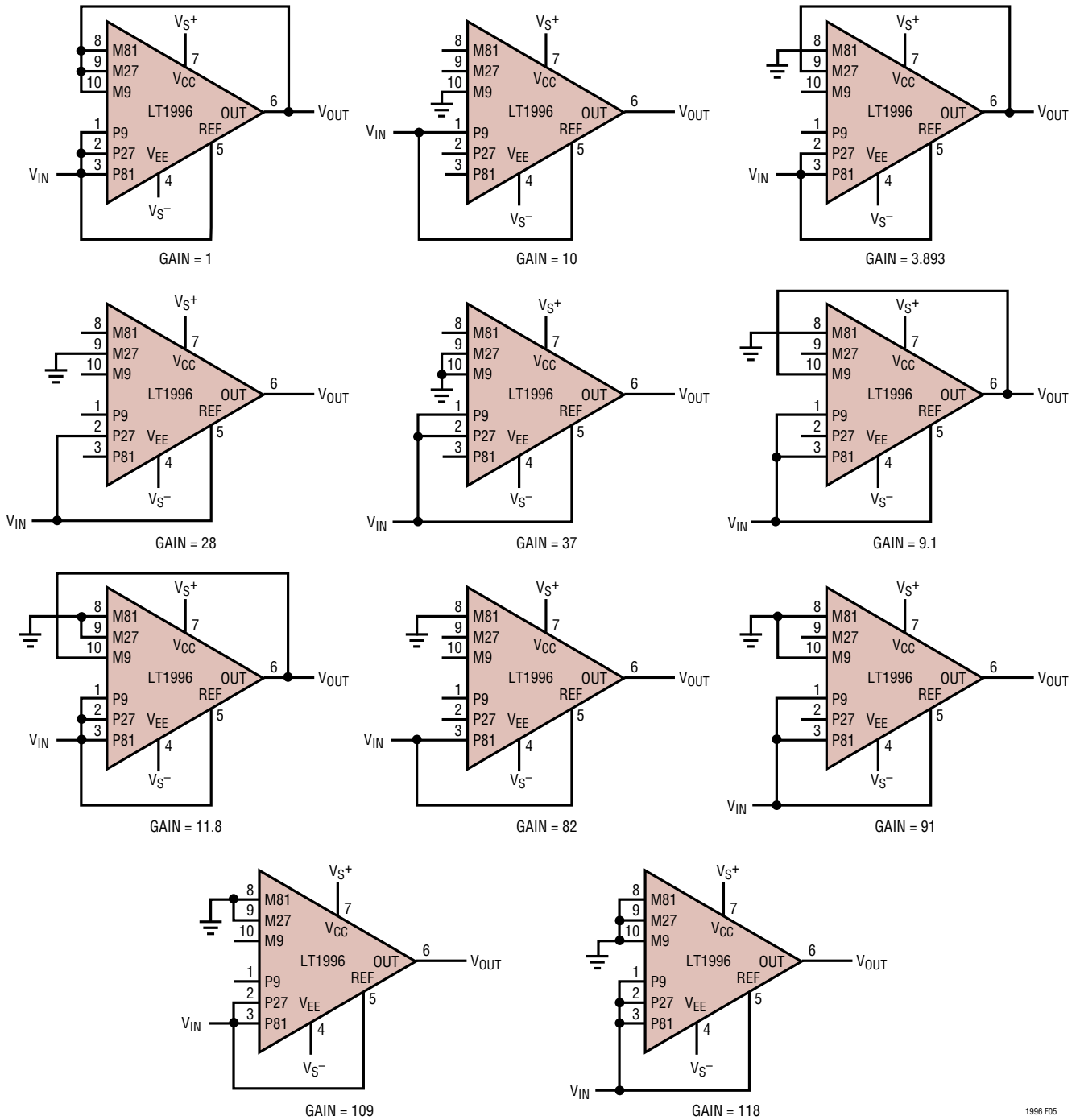

Figure 5. Some Implementations of Classical Noninverting Gains Using the LT1996. High Input Z Is Maintained

1996 F05

APPLICATIONS INFORMATION

Attenuation Using the P Input Resistors

Attenuation happens as a matter of fact in difference amplifier configurations, but it is also used for reducing peak signal level or improving input common mode range even in single ended systems. When signal conditioning indicates a need for attenuation, the LT1996 resistors are ready at hand. The four precision resistors can provide several attenuation levels, and these are tabulated in Table 2 as a design reference.

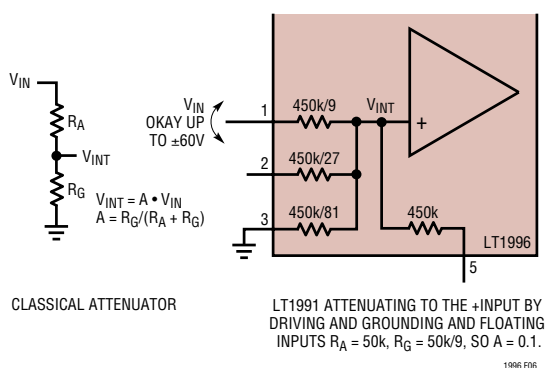

Figure 6. LT1996 Provides for Easy Attenuation to the Op Amp's +input. The P9 Input Can Be Taken Well Outside of the Supplies

Because the attenuations and the noninverting gains are set independently, they can be combined. This provides high gain resolution, about 700 unique gains between 0.0085 and 118, as plotted in Figure 7. This is too large a number to tabulate, but the designer can calculate achievable gain by taking the vector product of the gains and attenuations in Tables 1 and 2, and seeking the best match. Average gain resolution is 1.5%, with worst case steps of about 50% as seen in Figure 7.

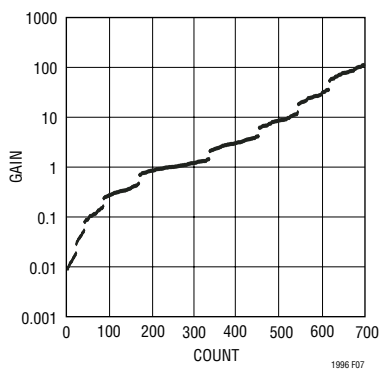

Figure 7. Over 600 Unique Gain Settings Achievable with the LT1996 by Combining Attenuation with Noninverting Gain

Table 2. Configuring the P Pins for Various Attenuations. Those Shown in Bold Are Functional Even When the Input Drive Exceeds the Supplies

A	P81, P27, P9, REF Connection			
	P81	P27	P9	REF
0.0085	Grounded	Grounded	Grounded	Driven
0.0092	Grounded	Grounded	Float	Driven
0.0110	Grounded	Float	Grounded	Driven
0.0122	Grounded	Float	Float	Driven
0.0270	Float	Grounded	Grounded	Driven
0.0357	Float	Grounded	Float	Driven
0.0763	Grounded	Grounded	Driven	Grounded
0.0769	Grounded	Grounded	Driven	Float
0.0847	Grounded	Grounded	Driven	Driven
0.0989	Grounded	Float	Driven	Grounded
0.1	Grounded	Float	Driven	Float
0.110	Grounded	Float	Driven	Driven
0.229	Grounded	Driven	Grounded	Grounded
0.231	Grounded	Driven	Grounded	Float
0.237	Grounded	Driven	Grounded	Driven
0.243	Float	Grounded	Driven	Grounded
0.248	Grounded	Driven	Float	Grounded
0.25	Float	Grounded	Driven	Float
0.25	Grounded	Driven	Float	Float
0.257	Grounded	Driven	Float	Driven
0.270	Float	Grounded	Driven	Driven
0.305	Grounded	Driven	Driven	Grounded
0.308	Grounded	Driven	Driven	Float
0.314	Grounded	Driven	Driven	Driven
0.686	Driven	Grounded	Grounded	Grounded
0.692	Driven	Grounded	Grounded	Float
0.695	Driven	Grounded	Grounded	Driven
0.730	Float	Driven	Grounded	Grounded
0.743	Driven	Grounded	Float	Grounded
0.75	Float	Driven	Grounded	Float
0.752	Driven	Grounded	Float	Driven
0.757	Float	Driven	Grounded	Driven
0.763	Driven	Grounded	Driven	Grounded
0.769	Driven	Grounded	Driven	Float
0.771	Driven	Grounded	Driven	Driven
0.890	Driven	Float	Grounded	Grounded
0.9	Float	Float	Driven	Grounded
0.901	Driven	Float	Grounded	Driven
0.915	Driven	Driven	Grounded	Grounded
0.923	Driven	Driven	Grounded	Float
0.924	Driven	Driven	Grounded	Driven
0.964	Float	Driven	Float	Grounded
0.973	Float	Driven	Driven	Grounded
0.988	Driven	Float	Float	Grounded
0.989	Driven	Float	Driven	Grounded
0.991	Driven	Driven	Float	Grounded
0.992	Driven	Driven	Driven	Grounded

APPLICATIONS INFORMATION

Inverting Configuration

The inverting amplifier, shown in Figure 8, is another classical op amp configuration. The circuit is actually identical to the noninverting amplifier of Figure 4, except that V_{IN} and GND have been swapped. The list of available gains is shown in Table 3, and some of the circuits are shown in Figure 9. Noise gain is $1+|Gain|$, as is the usual case for inverting amplifiers. Again, for the best DC performance, match the source impedance seen by the op amp inputs.

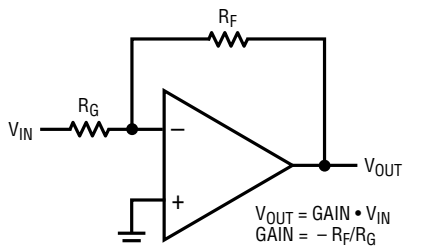

CLASSICAL INVERTING OP AMP CONFIGURATION. YOU PROVIDE THE RESISTORS.

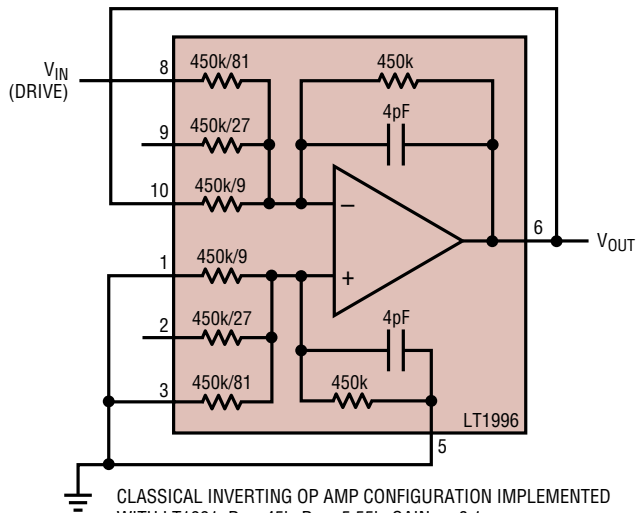

CLASSICAL INVERTING OP AMP CONFIGURATION IMPLEMENTED WITH LT1991. $R_F = 45k$, $R_G = 5.55k$, $GAIN = -8.1$.

GAIN IS ACHIEVED BY GROUNDING, FLOATING OR FEEDING BACK THE AVAILABLE RESISTORS TO ARRIVE AT DESIRED R_F AND R_G .

WE PROVIDE YOU WITH <0.1% RESISTORS.

1996 F08

Table 3. Configuring the M Pins for Simple Inverting Gains

Gain	M81, M27, M9 Connection		
	M81	M27	M9
-0.083	Output	Output	Drive
-0.110	Output	Float	Drive
-0.297	Output	Drive	Output
-0.321	Float	Output	Drive
-0.329	Output	Drive	Float
-0.439	Output	Drive	Drive
-2.19	Drive	Output	Output
-2.7	Float	Drive	Output
-2.89	Drive	Output	Float
-3.21	Drive	Output	Drive
-8.1	Drive	Float	Output
-9	Float	Float	Drive
-10.8	Drive	Drive	Output
-27	Float	Drive	Float
-36	Float	Drive	Drive
-81	Drive	Float	Float
-90	Drive	Float	Drive
-108	Drive	Drive	Float
-117	Drive	Drive	Drive

Figure 8. The LT1996 as a Classical Inverting Op Amp. Note the Circuit Is Identical to the Noninverting Amplifier, Except that V_{IN} and Ground Have Been Swapped

APPLICATIONS INFORMATION

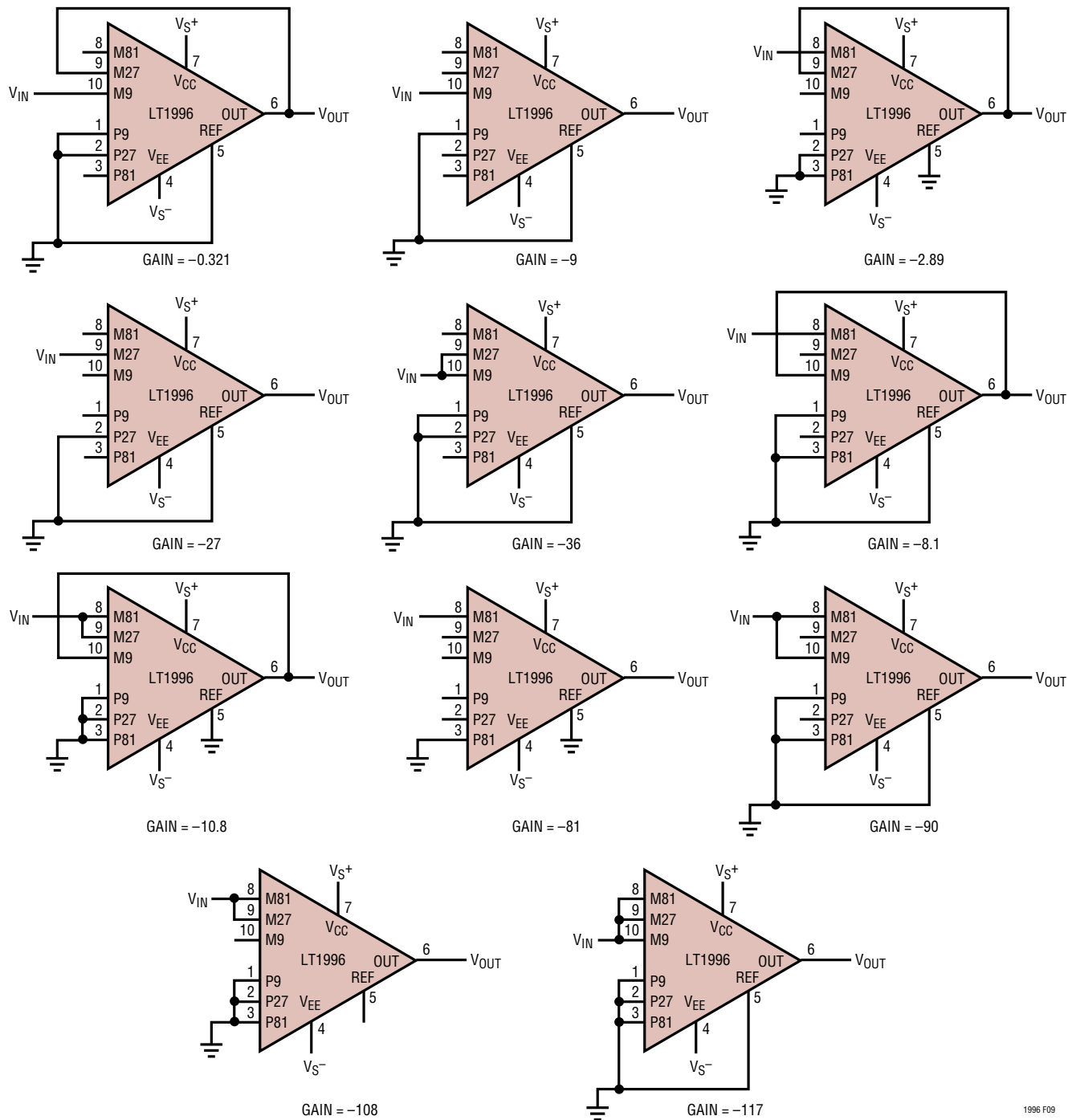

Figure 9. It Is Simple to Get Precision Inverting Gains with the LT1996. Input Impedance Varies from 3.8kΩ (Gain = -117) to 50kΩ (Gain = -9)

1996 F09

APPLICATIONS INFORMATION

Difference Amplifiers

The resistors in the LT1996 allow it to easily make difference amplifiers also. Figure 10 shows the basic 4-resistor difference amplifier and the LT1996. A difference gain of 27 is shown, but notice the effect of the additional dashed connections. By connecting the 50k resistors in parallel, the gain is reduced by a factor of 10. Of course, with so many resistors, there are many possible gains. Table 4 shows the difference gains and how they are achieved. Note that, as for inverting amplifiers, the noise gain is 1 more than the signal gain.

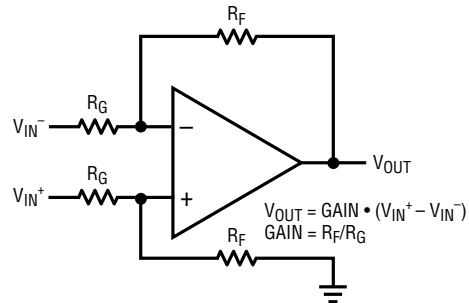

CLASSICAL DIFFERENCE AMPLIFIER USING THE LT1991

Table 4. Connections Giving Difference Gains for the LT1996

Gain	V _{IN} ⁺	V _{IN} ⁻	Output	GND (REF)
0.083	P9	M9	M27, M81	P27, P81
0.110	P9	M9	M81	P81
0.297	P27	M27	M9, M81	P9, P81
0.321	P9	M9	M27	P27
0.329	P27	M27	M81	P81
0.439	P9, P27	M9, M27	M81	P81
2.189	P81	M81	M9, M27	P9, P27
2.700	P27	M27	M9	P9
2.893	P81	M81	M27	P27
3.214	P9, P81	M9, M81	M27	P27
8.1	P81	M81	M9	P9
9	P9	M9		
10.8	P27, P81	M27, M81	M9	P9
27	P27	M27		
36	P9, P27	M9, M27		
81	P81	M81		
90	P9, P81	M9, M81		
108	P27, P81	M27, M81		
117	P9, P27, P81	M9, M27, M81		

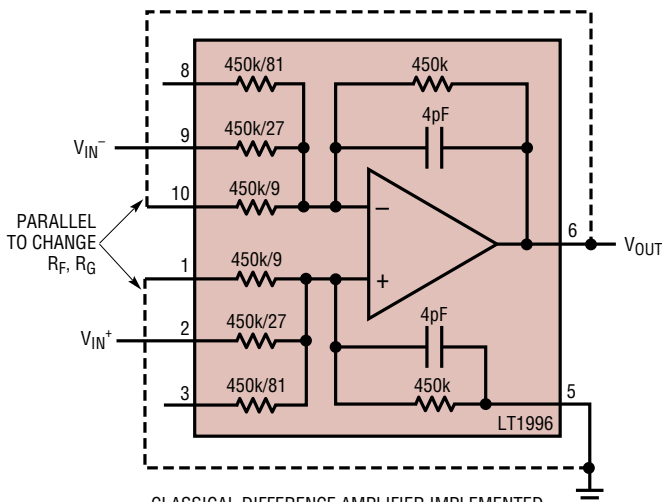

CLASSICAL DIFFERENCE AMPLIFIER IMPLEMENTED WITH LT1991. R_F = 450k, R_G = 16.7k, GAIN = 3.

ADDING THE DASHED CONNECTIONS CONNECTS THE TWO 450k RESISTOR IN PARALLEL, SO R_F IS REDUCED TO 45k. GAIN BECOMES 45k/16.7k = 2.7.

1996 F10

Figure 10. Difference Amplifier Using the LT1996. Gain Is Set Simply by Connecting the Correct Resistors or Combinations of Resistors. Gain of 27 Is Shown, with Dashed Lines Modifying It to Gain of 2.7. Noise Gain Is Optimal

APPLICATIONS INFORMATION

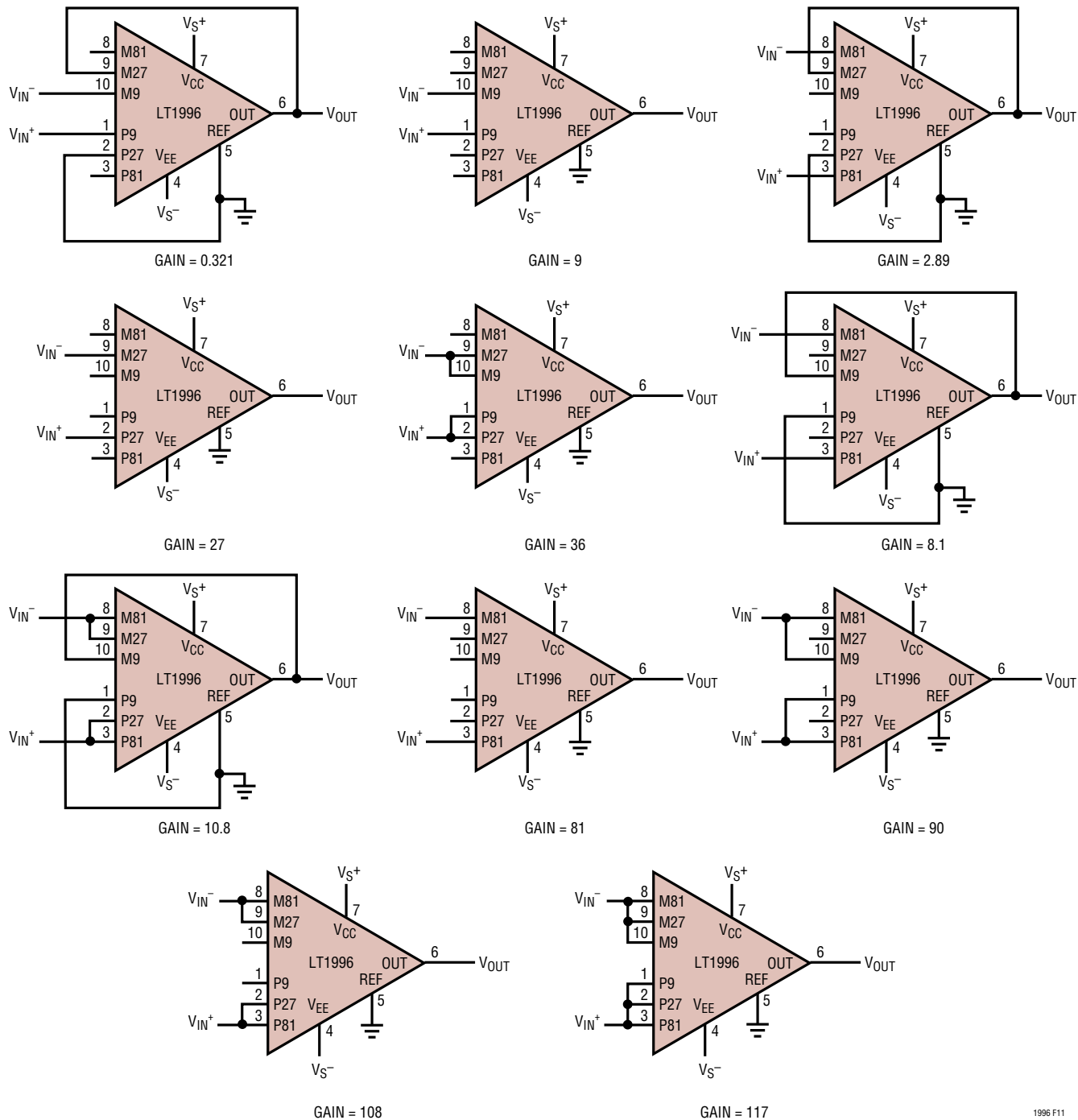
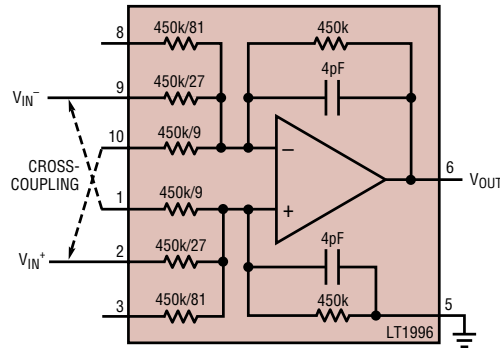
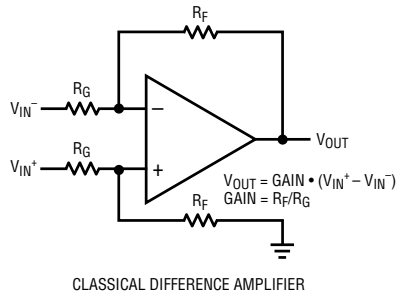

Figure 11. Many Difference Gains Are Achievable Just by Strapping the Pins

1996 F11

APPLICATIONS INFORMATION



CLASSICAL DIFFERENCE AMPLIFIER IMPLEMENTED WITH LT1991. $R_F = 450k$, $R_G = 16.7k$, $GAIN = 27$. GAIN CAN BE ADJUSTED BY "CROSS COUPLING." MAKING THE DASHED CONNECTIONS REDUCE THE GAIN FROM 3 TO 2. WHEN CROSS COUPLING, SEE WHAT IS CONNECTED TO THE V_{IN+} VOLTAGE. CONNECTING P27 AND M9 GIVES $27 - 9 = 18$. CONNECTIONS TO V_{IN-} ARE SYMMETRIC: M27 AND P9.

Figure 12. Another Method of Selecting Difference Gain Is "Cross-Coupling." The Additional Method Means the LT1996 Provides Extra Integer Gains

Difference Amplifier: Additional Integer Gains Using Cross-Coupling

Figure 12 shows the basic difference amplifier as well as the LT1996 in a difference gain of 27. But notice the effect of the additional dashed connections. This is referred to as "cross-coupling" and has the effect of reducing the differential gain from 27 to 18. Using this method, additional integer gains are achievable, as shown in Table 5 below. Note that the equations can be written by inspection from the V_{IN+} connections, and that the V_{IN-} connections are simply the opposite (swap P for M and M for P). The method is the same as for the LT1991, except that the LT1996 applies a multiplier of 9. Noise gain, bandwidth, and input impedance specifications for the various cases are also tabulated, as these are not obvious. Schematics are provided in Figure 13.

Table 5. Connections Using Cross-Coupling. Note That Equations Can Be Written by Inspection of the V_{IN+} Column

Gain	V_{IN+}	V_{IN-}	Gain Equation	Noise Gain	-3dB BW kHz	R_{IN+} Typ k Ω	R_{IN-} Typ k Ω
18	P27, M9	M27, P9	$27 - 9$	39	14	46	16
45	P81, M27, M9	M81, P27, P9	$81 - 27 - 9$	117	5	12	6
54	P81, M27	M81, P27	$81 - 27$	108	5	16	6
63	P81, P9, M27	M81, M9, P27	$81 + 9 - 27$	117	5	16	5
72	P81, M9	M81, P9	$81 - 9$	90	6	45	6
99	P81, P27, M9	M81, M27, P9	$81 + 27 - 9$	117	5	45	4

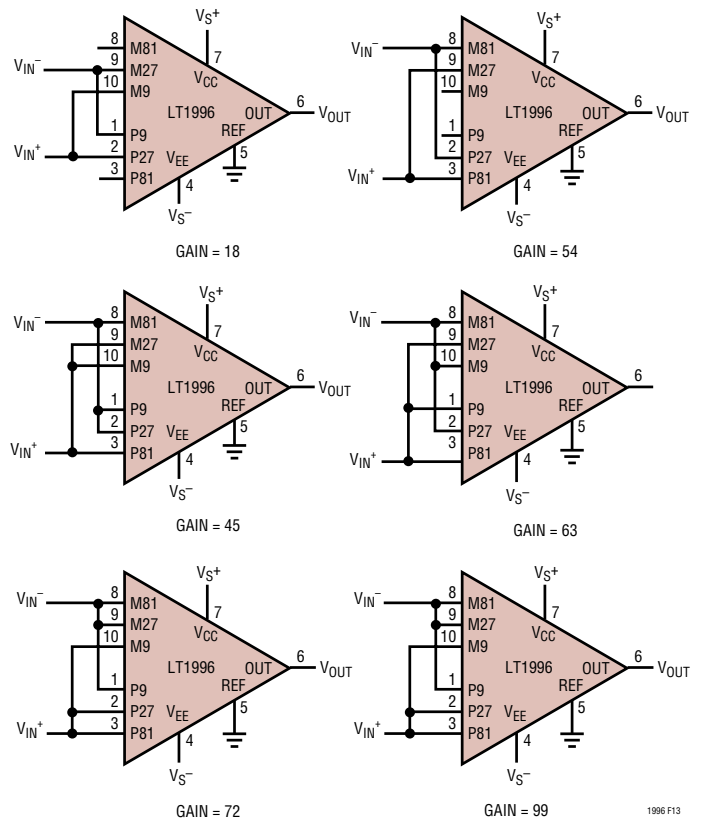

Figure 13. Integer Gain Difference Amplifiers Using Cross-Coupling

APPLICATIONS INFORMATION

High Voltage CM Difference Amplifiers

This class of difference amplifier remains to be discussed. Figure 14 shows the basic circuit on the top. The effective input voltage range of the circuit is extended by the fact that resistors R_T attenuate the common mode voltage seen by the op amp inputs. For the LT1996, the most useful resistors for R_G are the M9 and P9 50kΩ resistors, because they do not have diode clamps to the supplies and therefore can be taken outside the supplies. As before, the input CM of the op amp is the limiting factor and is set by the voltage at the op amp +input, V_{INT} . By superposition we can write:

$$V_{INT} = V_{EXT} \cdot (R_F || R_T) / (R_G + R_F || R_T) + V_{REF} \cdot (R_G || R_T) / (R_F + R_G || R_T) + V_{TERM} \cdot (R_F || R_G) / (R_T + R_F || R_G)$$

Solving for V_{EXT} :

$$V_{EXT} = (1 + R_G / (R_F || R_T)) \cdot (V_{INT} - V_{REF} \cdot (R_G || R_T) / (R_F + R_G || R_T)) - V_{TERM} \cdot (R_F || R_G) / (R_T + R_F || R_G)$$

Given the values of the resistors in the LT1996, this equation has been simplified and evaluated, and the resulting equations provided in Table 6. As before, substituting $V_{CC} - 1.2$ and $V_{EE} + 1$ for V_{LIM} will give the valid upper and lower common mode extremes respectively. Following are sample calculations for the case shown in Figure 14, right-hand side. Note that P81 and M81 are terminated so row 3 of Table 6 provides the equation:

$$\begin{aligned} \text{MAX } V_{EXT} &= 91/9 \cdot (V_{CC} - 1.2V) - V_{REF}/9 - 9 \cdot V_{TERM} \\ &= (10.11) \cdot (10.8) - 0.11(2.5) - 9(10) = 18.9V \end{aligned}$$

and:

$$\begin{aligned} \text{MIN } V_{EXT} &= 91/9 \cdot (V_{EE} + 1V) - V_{REF}/9 - 9 \cdot V_{TERM} \\ &= (10.11)(1) - 0.11(2.5) - 9(10) = -80.2V \end{aligned}$$

but this exceeds the 60V absolute maximum rating of the P9, M9 pins, so $-60V$ becomes the de facto negative common mode limit. Several more examples of high CM circuits are shown in Figures 15, 16, 17 for various supplies.

Table 6. HighV CM Connections Giving Difference Gains for the LT1996

Gain	V_{IN}^+	V_{IN}^-	R_T	Noise Gain	Max, Min V_{EXT} (Substitute $V_{CC} - 1.2$, $V_{EE} + 1$ for V_{LIM})
9	P9	M9		10	$10/9 \cdot V_{LIM} - V_{REF}/9$
9	P9	M9	P27, M27	37	$37/9 \cdot V_{LIM} - V_{REF}/9 - 3 \cdot V_{TERM}$
9	P9	M9	P81, M81	91	$91/9 \cdot V_{LIM} - V_{REF}/9 - 9 \cdot V_{TERM}$
9	P9	M9	P27 P81 M27 M81	118	$118/9 \cdot V_{LIM} - V_{REF}/9 - 12 \cdot V_{TERM}$

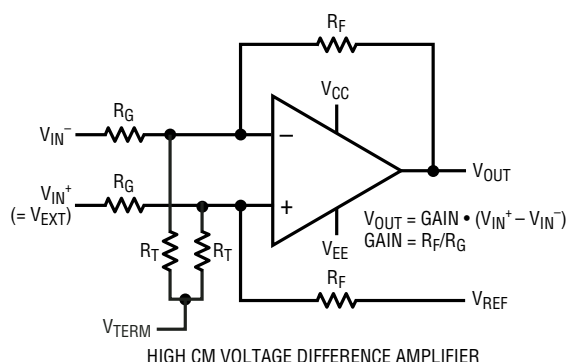

HIGH CM VOLTAGE DIFFERENCE AMPLIFIER

INPUT CM TO OP AMP IS ATTENUATED BY RESISTORS R_T CONNECTED TO V_{TERM} .

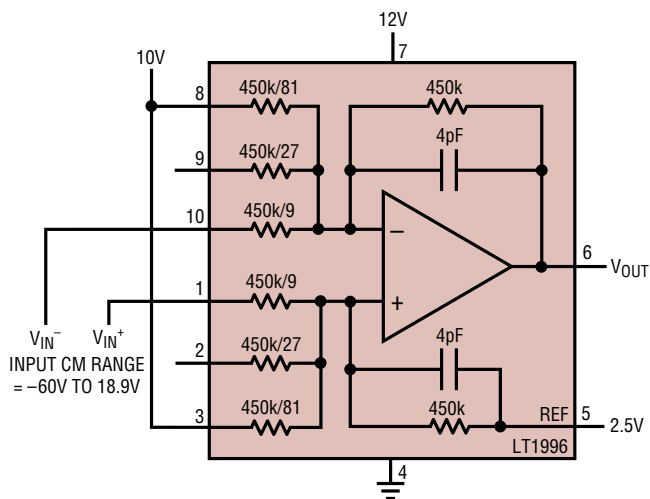

HIGH NEGATIVE CM VOLTAGE DIFFERENCE AMPLIFIER IMPLEMENTED WITH LT1996.
 $R_F = 450k$, $R_G = 50k$, $R_T = 5.55k$, $GAIN = 9$

$V_{TERM} = 10V = V_{CC} = 12V$, $V_{REF} = 2.5V$, $V_{EE} = 0V$.

1996 F14

Figure 14. Extending CM Input Range

APPLICATIONS INFORMATION

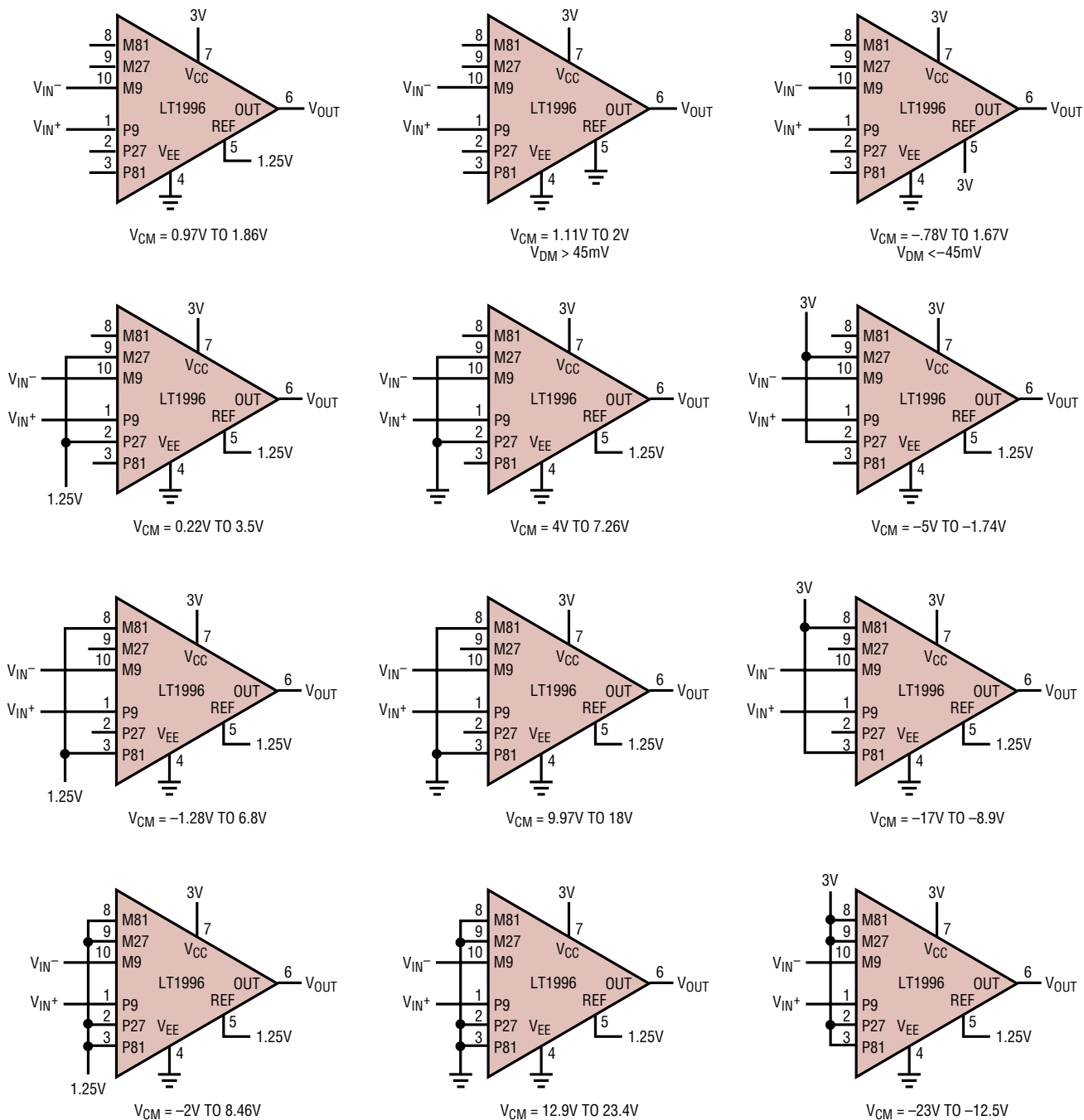

1996 F15

Figure 15. Common Mode Ranges for Various LT1996 Difference Amp Configurations on $V_S = 3V, 0V$, with Gain = 9

APPLICATIONS INFORMATION

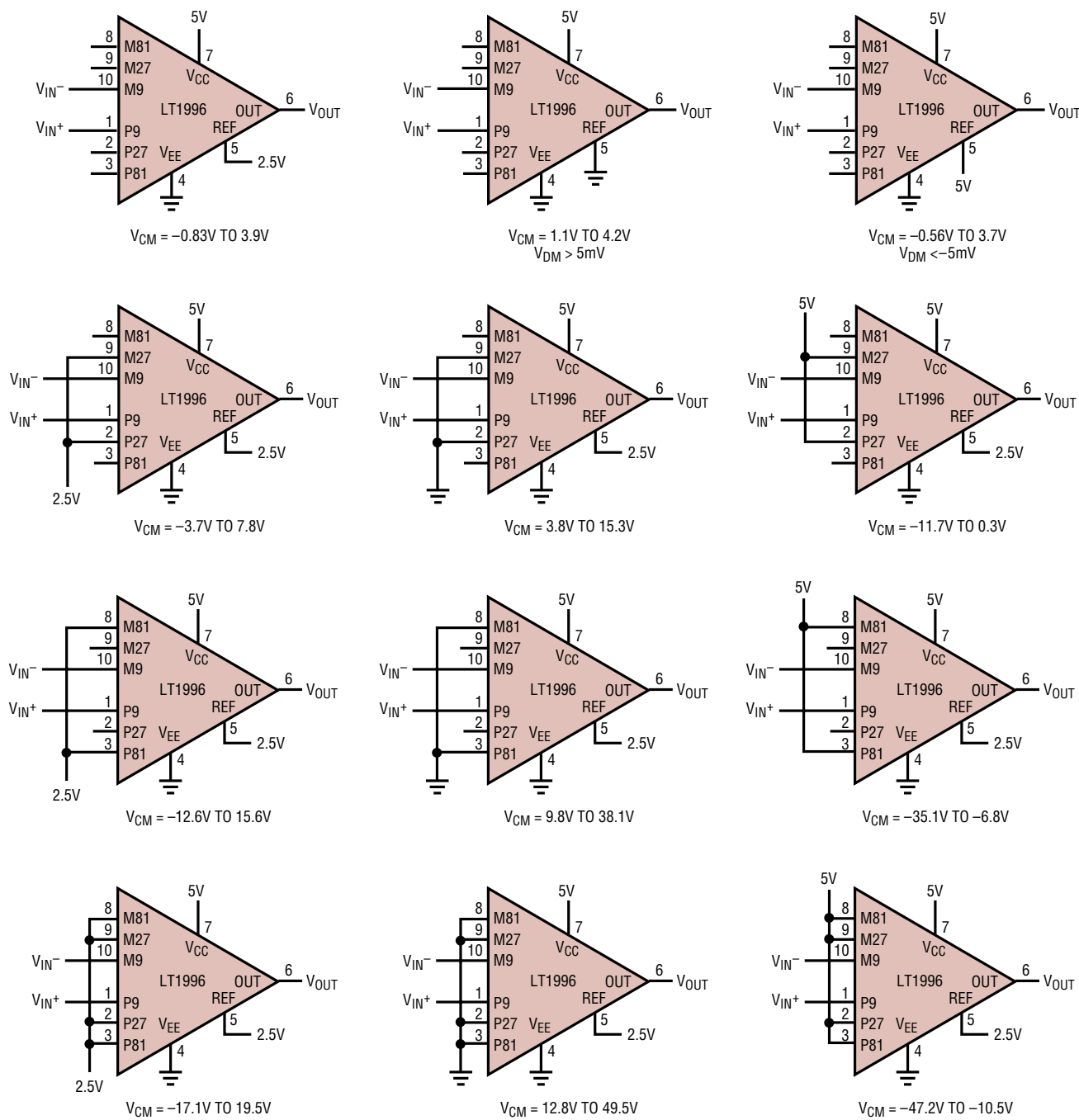
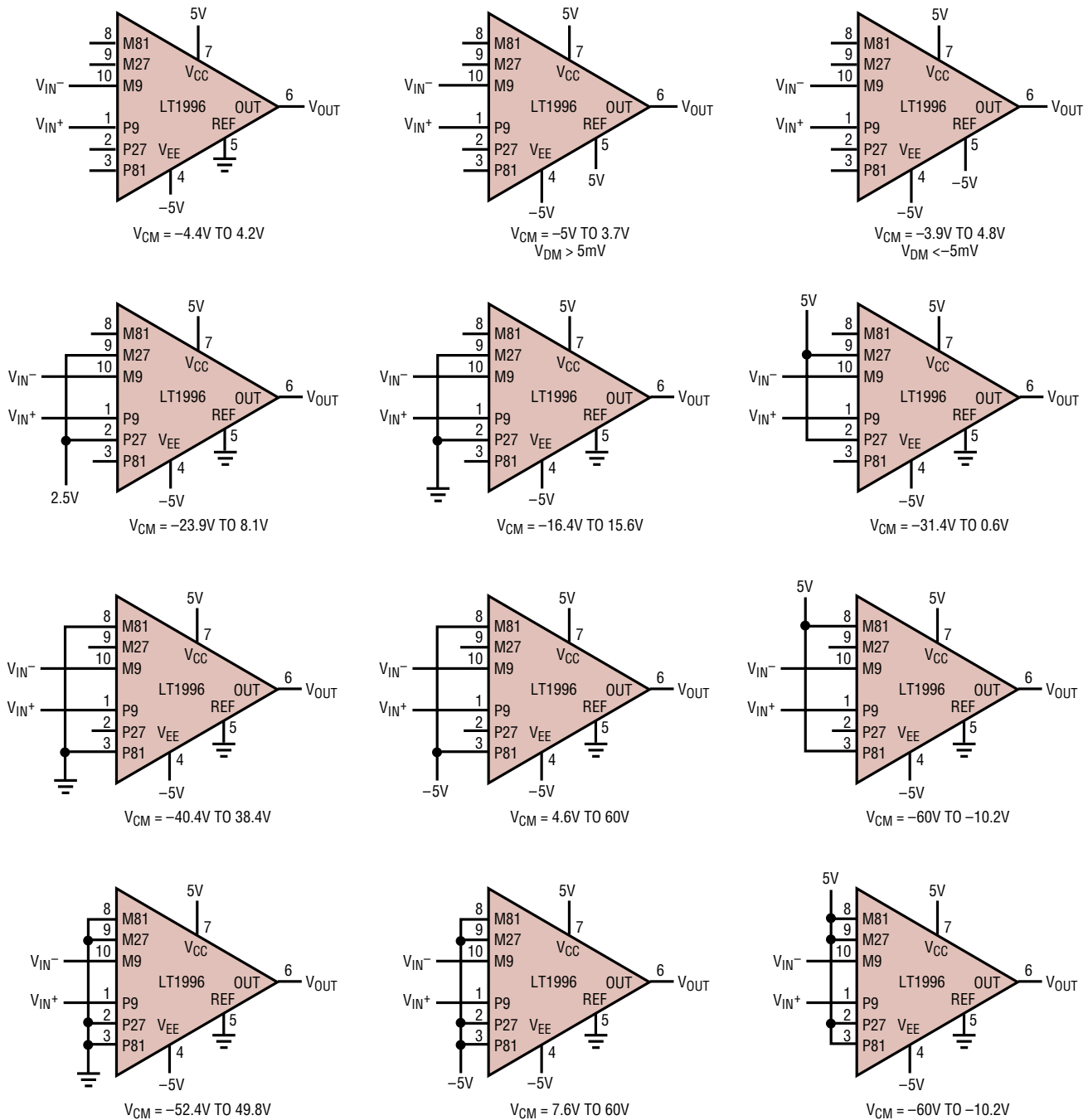

Figure 16. Common Mode Ranges for Various LT1996 Difference Amp Configurations on V_S = 5V, 0V, with Gain = 9

1996 F16

APPLICATIONS INFORMATION



1996 F17

Figure 17. Common Mode Ranges for Various LT1996 Difference Amp Configurations on $V_S = \pm 5V$, with Gain = 9

PACKAGE DESCRIPTION

DD Package 10-Lead Plastic DFN (3mm × 3mm) (Reference LTC DWG # 05-08-1699)

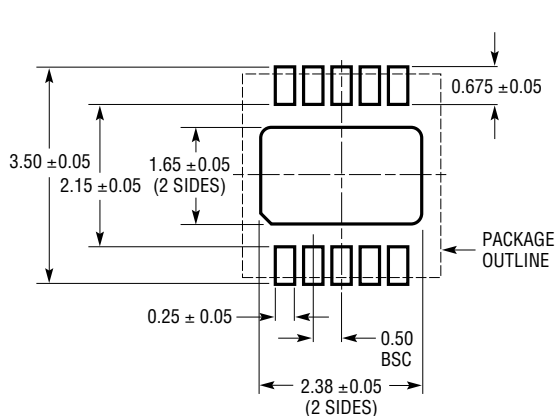

RECOMMENDED SOLDER PAD PITCH AND DIMENSIONS

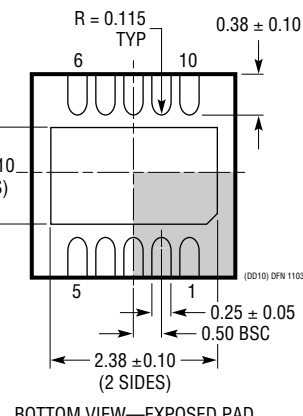
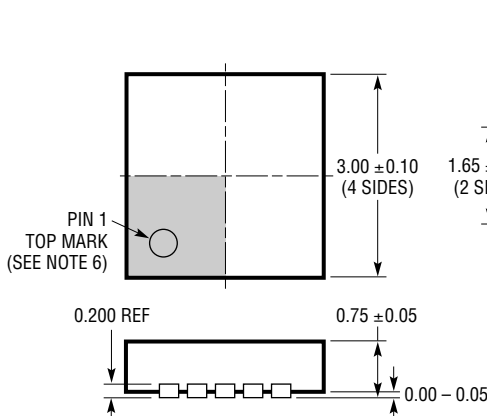

BOTTOM VIEW—EXPOSED PAD

NOTE:

1. DRAWING TO BE MADE A JEDEC PACKAGE OUTLINE M0-229 VARIATION OF (WEED-2). CHECK THE LTC WEBSITE DATA SHEET FOR CURRENT STATUS OF VARIATION ASSIGNMENT
2. DRAWING NOT TO SCALE
3. ALL DIMENSIONS ARE IN MILLIMETERS
4. DIMENSIONS OF EXPOSED PAD ON BOTTOM OF PACKAGE DO NOT INCLUDE MOLD FLASH. MOLD FLASH, IF PRESENT, SHALL NOT EXCEED 0.15mm ON ANY SIDE
5. EXPOSED PAD SHALL BE SOLDER PLATED
6. SHADED AREA IS ONLY A REFERENCE FOR PIN 1 LOCATION ON THE TOP AND BOTTOM OF PACKAGE

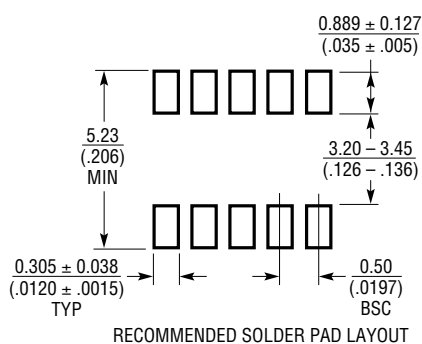

RECOMMENDED SOLDER PAD LAYOUT

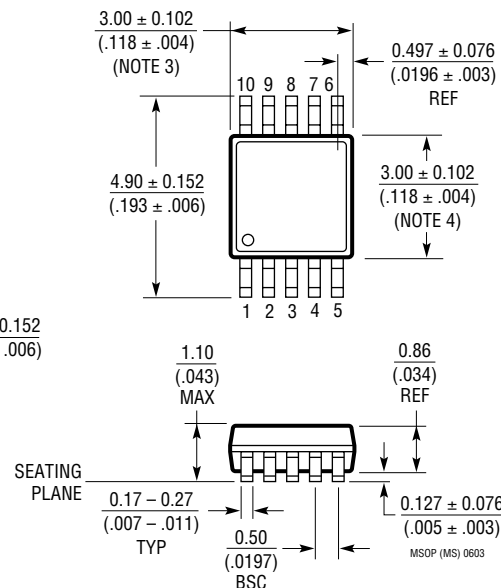
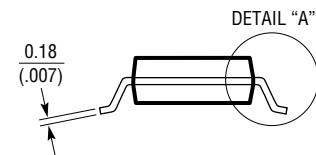
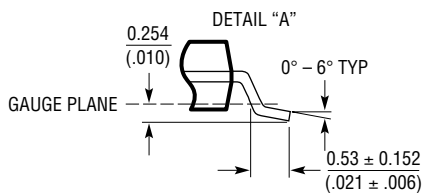

NOTE:

1. DIMENSIONS IN MILLIMETER/(INCH)
2. DRAWING NOT TO SCALE
3. DIMENSION DOES NOT INCLUDE MOLD FLASH, PROTRUSIONS OR GATE BURRS. MOLD FLASH, PROTRUSIONS OR GATE BURRS SHALL NOT EXCEED 0.152mm (.006") PER SIDE
4. DIMENSION DOES NOT INCLUDE INTERLEAD FLASH OR PROTRUSIONS. INTERLEAD FLASH OR PROTRUSIONS SHALL NOT EXCEED 0.152mm (.006") PER SIDE
5. LEAD COPLANARITY (BOTTOM OF LEADS AFTER FORMING) SHALL BE 0.102mm (.004") MAX

TYPICAL APPLICATION

Micropower $A_V = 90$ Instrumentation Amplifier

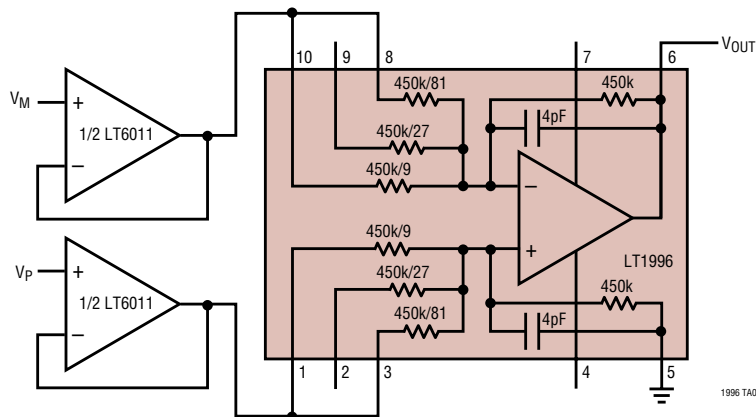

Bidirectional Controlled Current Source

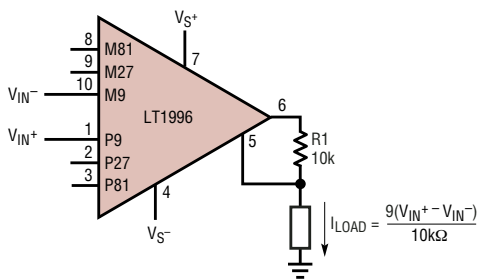

AC Coupled Amplifier

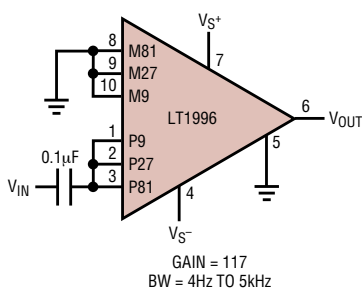

Differential Input/Output $G = 9$ Amplifier

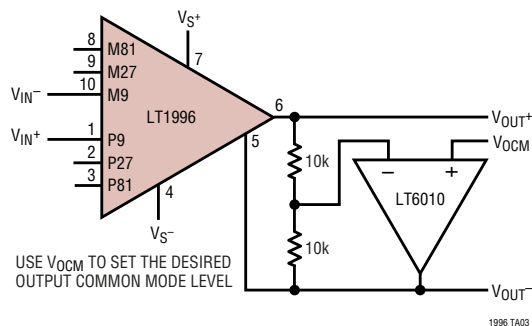

RELATED PARTS

PART NUMBER	DESCRIPTION	COMMENTS
LT1990	High Voltage Difference Amplifier	$\pm 250V$ Input Common Mode, Micropower, Pin Selectable Gain = 1, 10
LT1991	Precision, 100 μA Gain Selectable Amplifier	Gain Resistors of 450k, 150k, 50k
LT1995	30MHz, 1000V/ μs Gain Selectable Amplifier	High Speed, Pin Selectable Gain = -7 to 8
LT6010/LT6011/LT6012	Single/Dual/Quad Precision Op Amp	Similar Performance as LT1996 Diff Amp, 135 μA , 14nV/ \sqrt{Hz} , Rail-to-Rail Out
LT6013/LT6014	Single/Dual Precision Op Amp	Lower Noise $A_V \geq 5$ Version of LT1991, 145 μA , 8nV/ \sqrt{Hz} , Rail-to-Rail Out
LTC6910-X	Programmable Gain Amplifiers	3 Gain Configurations, Rail-to-Rail Input and Output