

# Precision, Gain Selectable High Side Current Sense Amplifier

## FEATURES

- Input Offset Voltage: 300 $\mu$ V (Max)
- Sense Inputs Up to 48V
- 0.5% Gain Accuracy
- Pin Selectable Gain: 10, 12.5, 20, 25, 40, 50V/V
- Separate Power Supply: 2.7V to 36V
- Operating Current: 60 $\mu$ A
- Sense Input Current ( $V_{CC}$  Powered Down): 1nA
- Reverse Battery Protected to -48V
- Buffered Output
- Noise Filtering Input
- -40°C to 125°C Operating Temperature Range
- Available in 8-Lead DFN and MSOP Packages

## APPLICATIONS

- Battery Monitoring
- Fuse Monitoring
- Portable and Cellular Phones
- Portable Test/Measurement Systems

LT, LT, LTC and LTM are registered trademarks of Linear Technology Corporation. All other trademarks are the property of their respective owners.

## DESCRIPTION

The LT<sup>®</sup>6100 is a complete micropower, precision, high side current sense amplifier. The LT6100 monitors unidirectional currents via the voltage across an external sense resistor. Fixed gains of 10, 12.5, 20, 25, 40, 50V/V are obtained by simply strapping or floating two gain select pins. Gain accuracy is better than 0.5% for all gains.

The LT6100 sense inputs have a voltage range that extends from 4.1V to 48V, and can withstand a differential voltage of the full supply. This makes it possible to monitor the voltage across a MOSFET switch or a fuse. The part can also withstand a reverse battery condition on the inputs.

Input offset is a low 300 $\mu$ V. CMRR and PSRR are in excess of 105dB, resulting in a wide dynamic range. A filter pin is provided to easily implement signal filtering with a single capacitor.

The LT6100 has a separate supply input, which operates from 2.7V to 36V and draws only 60 $\mu$ A. When  $V_{CC}$  is powered down, the sense pins are biased off. This prevents loading of the monitored circuit, irrespective of the sense voltage. The LT6100 is available in an 8-lead DFN and MSOP package.

## TYPICAL APPLICATION

### 0A to 33A High Side Current Monitor with 12kHz Frequency Roll-off

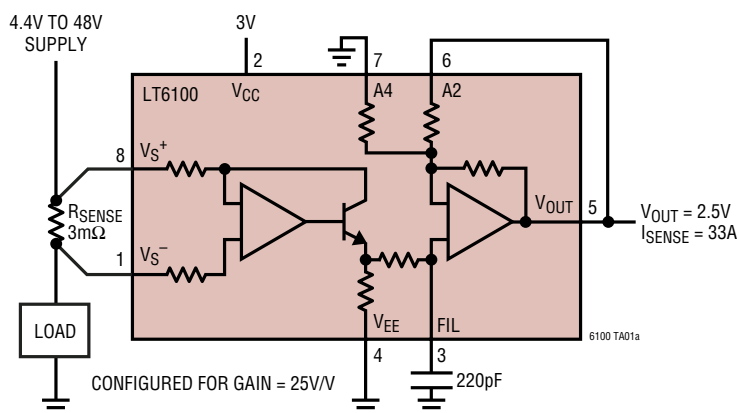

Input Offset Voltage  
vs  $V_S$  Sense Input Voltage

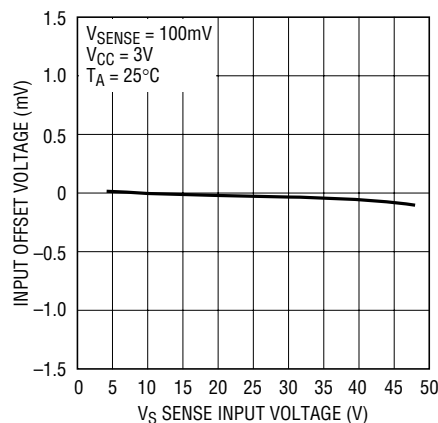

6100 TA01b

# LT6100

## ABSOLUTE MAXIMUM RATINGS (Notes 1, 2)

|   |                                    |                                      |                |
|---|------------------------------------|--------------------------------------|----------------|
| Differential Sense Voltage .....                  | ±48V                               | Specified Temperature Range (Note 5) |                |
| Total $V_{S^+}$ , $V_{S^-}$ to $V_{EE}$ .....     | 48V                                | LT6100C .....                        | -40°C to 85°C  |
| Total $V_{CC}$ Supply Voltage from $V_{EE}$ ..... | 36V                                | LT6100I .....                        | -40°C to 85°C  |
| Output Voltage .....                              | ( $V_{EE}$ ) to ( $V_{EE} + 36V$ ) | LT6100H .....                        | -40°C to 125°C |
| Output Short-Circuit Duration (Note 3) .....      | Continuous                         | Storage Temperature Range .....      |                |
| Operating Temperature Range (Note 4)              |                                    | DFN .....                            | -65°C to 125°C |
| LT6100C .....                                     | -40°C to 85°C                      | MSOP .....                           | -65°C to 150°C |
| LT6100I .....                                     | -40°C to 85°C                      | Lead Temperature (Soldering, 10 sec) |                |
| LT6100H .....                                     | -40°C to 125°C                     | MSOP .....                           | 300°C          |

## PACKAGE/ORDER INFORMATION

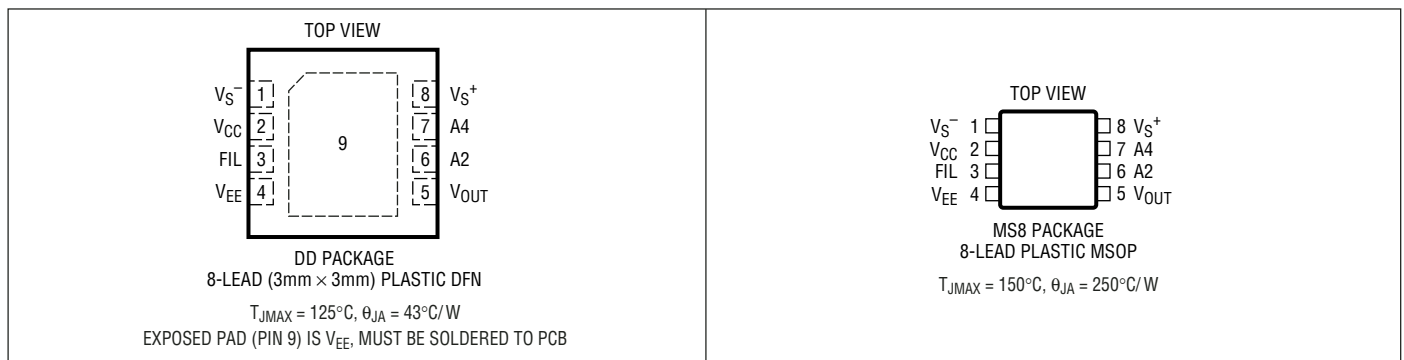

| ORDER PART NUMBER | DD PART MARKING* | ORDER PART NUMBER | MS PART MARKING* |
|-------------------|------------------|-------------------|------------------|
| LT6100CDD         | LBMW             | LT6100CMS8        | LTCBMV           |
| LT6100IDD         | LBMW             | LT6100IMS8        | LTCBMV           |
| LT6100HDD         | LBMW             | LT6100HMS8        | LTCBMV           |

**Order Options** Tape and Reel: Add #TR  
Lead Free: Add #PBF Lead Free Tape and Reel: Add #TRPBF  
Lead Free Part Marking: <http://www.linear.com/leadfree/>

Consult LTC Marketing for parts specified with wider operating temperature ranges. \*The temperature grades are identified by a label on the shipping container.

## ELECTRICAL CHARACTERISTICS

The ● denotes specifications which apply over the temperature range  $0^{\circ}\text{C} \leq T_A \leq 70^{\circ}\text{C}$  (LT6100C), otherwise specifications are  $T_A = 25^{\circ}\text{C}$ .  $V_{CC} = 5V$ ,  $V_{EE} = 0V$ ,  $V_{S^+} = V_{CC} + 1.4V$  unless otherwise specified. (Note 5)

| SYMBOL                | PARAMETER                           | CONDITIONS   | MIN | TYP  | MAX     | UNITS |
|-----------------------|-------------------------------------|--|-----|------|---------|-------|
| $V_{S^-}$ , $V_{S^+}$ | Sense Amplifier Supply Voltage      | $V_{CC} = 2.7V$  | ●   | 4.1  | 48      | V     |
| $V_{SENSE}$           | Input Sense Voltage Full Scale      | $V_{SENSE} = V_{S^+} - V_{S^-}$ , $V_{CC} = 3V$ , $A_V = 10V/V$<br>$V_{SENSE} = V_{S^+} - V_{S^-}$ , $V_{CC} = 5V$ , $A_V = 10V/V$ | ●   | 110  |         | mV    |
| $V_{OS}$              | Input Offset Voltage (MS Package)   | $I_{OUT} = 0$  | ●   | -300 | ±80 300 | μV    |
|                       | Input Offset Voltage (DD Package)   | $I_{OUT} = 0$  | ●   | -350 | ±80 350 | μV    |
| $V_{OS\ TC}$          | Temperature Coefficient of $V_{OS}$ | (Note 6)   | ●   | 0.5  | 3       | μV/°C |

## ELECTRICAL CHARACTERISTICS

The ● denotes specifications which apply over the temperature range  $0^{\circ}\text{C} \leq T_A \leq 70^{\circ}\text{C}$  (LT6100C), otherwise specifications are  $T_A = 25^{\circ}\text{C}$ .  $V_{CC} = 5\text{V}$ ,  $V_{EE} = 0\text{V}$ ,  $V_{S^+} = V_{CC} + 1.4\text{V}$  unless otherwise specified. (Note 5)

| SYMBOL                             | PARAMETER   | CONDITIONS  | MIN  | TYP   | MAX   | UNITS            |
|------------------------------------|---|---|------|-------|-------|------------------|
| $A_V$                              | Gain, $V_{OUT}/V_{SENSE}$   | $V_{SENSE} = 50\text{mV}$ to $80\text{mV}$ , $A_V = 10\text{V/V}$<br>LT6100MS8                                  | 9.95 |       | 10.05 | V/V              |
|                                    |   | LT6100DD8   | 9.94 |       | 10.06 | V/V              |
|                                    |   | $V_S = 48\text{V}$ , $V_{SENSE} = 50\text{mV}$ to $80\text{mV}$ , $A_V = 10\text{V/V}$                          | 9.90 |       | 10.10 | V/V              |
|                                    |   | $V_S = 48\text{V}$ , $V_{SENSE} = 50\text{mV}$ to $80\text{mV}$ , $A_V = 10\text{V/V}$                          | 9.90 |       | 10.10 | V/V              |
| Output Voltage Gain Error (Note 7) | $V_{SENSE} = 50\text{mV}$ to $80\text{mV}$ ,<br>$A_V = 10, 12.5, 20, 25, 40, 50\text{V/V}$<br>LT6100MS8 |   | -0.5 |       | 0.5   | %                |
|                                    |   |   | -0.6 |       | 0.6   | %                |
|                                    |   | $V_S = 48\text{V}$ , $V_{SENSE} = 50\text{mV}$ to $80\text{mV}$ ,<br>$A_V = 10, 12.5, 20, 25, 40, 50\text{V/V}$ | -1.0 |       | 1.0   | %                |
|                                    |   | $V_S = 48\text{V}$ , $V_{SENSE} = 50\text{mV}$ to $80\text{mV}$ ,<br>$A_V = 10, 12.5, 20, 25, 40, 50\text{V/V}$ | -1.0 |       | 1.0   | %                |
| $V_S$ CMRR                         | $V_S$ Sense Input Common Mode Rejection Ratio   | $V_{SENSE} = 50\text{mV}$ , $V_{CC} = 2.7\text{V}$ , $V_S = 4.1\text{V}$ to $36\text{V}$                        | 105  | 120   |       | dB               |
|                                    |   |   | 100  | 120   |       | dB               |
| $V_{CC}$ PSRR                      | $V_{CC}$ Supply Rejection Ratio   | $V_{SENSE} = 50\text{mV}$ , $V_S = 36\text{V}$ , $V_{CC} = 3\text{V}$ to $30\text{V}$                           | 105  | 120   |       | dB               |
|                                    |   |   | 100  | 120   |       | dB               |
| $V_{CC}$                           | Supply Voltage $V_{CC}$   |   | 2.7  |       | 36    | V                |
| BW                                 | Bandwidth   | $A_V = 10\text{V/V}$ , $f_0 = -3\text{dB}$ , $V_{CC} = 15\text{V}$  | 100  | 150   |       | kHz              |
|                                    |   | $A_V = 50\text{V/V}$ , $f_0 = -3\text{dB}$ , $V_{CC} = 15\text{V}$  | 20   | 50    |       | kHz              |
| $t_S$                              | Output Settling to 1% Final Value   | $V_{SENSE} = 10\text{mV}$ to $100\text{mV}$   |      | 15    |       | $\mu\text{s}$    |
| $I_{S^+}(0), I_{S^-}(0)$           | Sense Input Current   | $V_{SENSE} = 0\text{V}$   | ●    | 4.5   | 10    | $\mu\text{A}$    |
| $I_{CC}(0)$                        | $V_{CC}$ Supply Current   | $V_{SENSE} = 0\text{V}$   | ●    | 60    | 130   | $\mu\text{A}$    |
| SR                                 | Slew Rate (Note 8)  | $V_{CC} = 15\text{V}$ , $V_{SENSE} = 26\text{mV}$ to $380\text{mV}$ , $A_V = 50\text{V/V}$                      | ●    | 0.03  | 0.05  | V/ $\mu\text{s}$ |
|                                    |   |   | ●    | 0.02  | 0.05  | V/ $\mu\text{s}$ |
| $I_{SC}$                           | Short-Circuit Current   | $I_{SC}^+, I_{SC}^-$  |      | 8     | 15    | mA               |
|                                    | Reverse $V_S$ Supply  | $I_{S(TOTAL)} = -200\mu\text{A}$ , $V_{CC} = \text{Open}$   | ●    | 50    | 60    | V                |
| $V_{O(MIN)}$                       | Minimum Output Voltage  | $V_{SENSE} = 0\text{V}$ , No Load   | ●    | 15    | 30    | mV               |
|                                    |   | $V_{SENSE} = V_{S^+} - V_{S^-} = -100\text{mV}$ , $A_V = 50\text{V/V}$ , No Load                                | ●    | 15    | 25    | mV               |
| $V_{O(MAX)}$                       | Output High (Referred to $V_{CC}$ )   | $A_V = 50\text{V/V}$ , $V_{SENSE} = 100\text{mV}$ , $I_L = 0$   | ●    | 75    | 125   | mV               |
|                                    |   | $V_{SENSE} = 100\text{mV}$ , $I_L = 100\mu\text{A}$   | ●    | 85    | 150   | mV               |
|                                    |   | $V_{SENSE} = 100\text{mV}$ , $I_L = 500\mu\text{A}$   | ●    | 125   | 250   | mV               |
|                                    |   | $V_{SENSE} = 100\text{mV}$ , $I_L = 1\text{mA}$   | ●    | 175   | 400   | mV               |
| $I_{S^+}, I_{S^-}$ (Off)           | Sense Input Current (Power Down)  | $V_{CC} = 0\text{V}$ , $V_S = 48\text{V}$ , $V_{SENSE} = 0\text{V}$   | ●    | 0.001 | 1     | $\mu\text{A}$    |

The ● denotes specifications which apply over the temperature range  $-40^{\circ}\text{C} \leq T_A \leq 85^{\circ}\text{C}$  (LT6100I), otherwise specifications are  $T_A = 25^{\circ}\text{C}$ .  $V_{CC} = 5\text{V}$ ,  $V_{EE} = 0\text{V}$ ,  $V_{S^+} = V_{CC} + 1.4\text{V}$  unless otherwise specified. (Note 5)

| SYMBOL             | PARAMETER                           | CONDITIONS  | MIN | TYP  | MAX      | UNITS                          |               |
|--------------------|-------------------------------------|---|-----|------|----------|--------------------------------|---------------|
| $V_{S^-}, V_{S^+}$ | Sense Amplifier Supply Voltage      | $V_{CC} = 2.7\text{V}$  | ●   | 4.1  | 48       | V                              |               |
| $V_{SENSE}$        | Input Sense Voltage Full Scale      | $V_{SENSE} = V_{S^+} - V_{S^-}$ , $V_{CC} = 3\text{V}$ , $A_V = 10\text{V/V}$ | ●   | 110  |          | mV                             |               |
|                    |                                     | $V_{SENSE} = V_{S^+} - V_{S^-}$ , $V_{CC} = 5\text{V}$ , $A_V = 10\text{V/V}$ | ●   | 300  |          | mV                             |               |
| $V_{OS}$           | Input Offset Voltage (MS Package)   | $I_{OUT} = 0$   | ●   | -300 | $\pm 80$ | 300                            | $\mu\text{V}$ |
|                    |                                     |   | ●   | -550 |          | 550                            | $\mu\text{V}$ |
|                    | Input Offset Voltage (DD Package)   | $I_{OUT} = 0$   | ●   | -350 | $\pm 80$ | 350                            | $\mu\text{V}$ |
|                    |                                     |   | ●   | -600 |          | 600                            | $\mu\text{V}$ |
| $V_{OS}$ TC        | Temperature Coefficient of $V_{OS}$ | (Note 6)  | ●   | 0.5  | 3        | $\mu\text{V}/^{\circ}\text{C}$ |               |

## ELECTRICAL CHARACTERISTICS

The ● denotes specifications which apply over the temperature range  $-40^{\circ}\text{C} \leq T_A \leq 85^{\circ}\text{C}$  (LT6100I), otherwise specifications are  $T_A = 25^{\circ}\text{C}$ .  $V_{CC} = 5\text{V}$ ,  $V_{EE} = 0\text{V}$ ,  $V_{S^+} = V_{CC} + 1.4\text{V}$  unless otherwise specified. (Note 5)

| SYMBOL                   | PARAMETER                                     | CONDITIONS  | MIN  | TYP   | MAX   | UNITS            |
|--------------------------|---|---|------|-------|-------|------------------|
| $A_V$                    | Gain, $V_{OUT}/V_{SENSE}$                     | $V_{SENSE} = 50\text{mV}$ to $80\text{mV}$ , $A_V = 10\text{V/V}$<br>LT6100MS8                                  | 9.95 |       | 10.05 | V/V              |
|                          |   | LT6100DD8   | 9.94 |       | 10.06 | V/V              |
|                          |   | $V_S = 48\text{V}$ , $V_{SENSE} = 50\text{mV}$ to $80\text{mV}$ , $A_V = 10\text{V/V}$                          | 9.90 |       | 10.10 | V/V              |
|                          | Output Voltage Gain Error (Note 7)            | $V_{SENSE} = 50\text{mV}$ to $80\text{mV}$ ,<br>$A_V = 10, 12.5, 20, 25, 40, 50\text{V/V}$<br>LT6100MS8         | -0.5 |       | 0.5   | %                |
|                          | LT6100DD8                                     | -0.6  |      | 0.6   | %     |                  |
|                          |   | $V_S = 48\text{V}$ , $V_{SENSE} = 50\text{mV}$ to $80\text{mV}$ ,<br>$A_V = 10, 12.5, 20, 25, 40, 50\text{V/V}$ | -1.0 |       | 1.0   | %                |
| $V_S$ CMRR               | $V_S$ Sense Input Common Mode Rejection Ratio | $V_{SENSE} = 50\text{mV}$ , $V_{CC} = 2.7\text{V}$ , $V_S = 4.1\text{V}$ to $36\text{V}$                        | 105  | 120   |       | dB               |
|                          |   |   | 100  | 120   |       | dB               |
| $V_{CC}$ PSRR            | $V_{CC}$ Supply Rejection Ratio               | $V_{SENSE} = 50\text{mV}$ , $V_S = 36\text{V}$ , $V_{CC} = 3\text{V}$ to $30\text{V}$                           | 105  | 120   |       | dB               |
|                          |   |   | 100  | 120   |       | dB               |
| $V_{CC}$                 | Supply Voltage $V_{CC}$                       |   | 2.7  |       | 36    | V                |
| BW                       | Bandwidth                                     | $A_V = 10\text{V/V}$ , $f_0 = -3\text{dB}$ , $V_{CC} = 15\text{V}$  | 100  | 150   |       | kHz              |
|                          |   | $A_V = 50\text{V/V}$ , $f_0 = -3\text{dB}$ , $V_{CC} = 15\text{V}$  | 20   | 50    |       | kHz              |
| $t_S$                    | Output Settling to 1% Final Value             | $V_{SENSE} = 10\text{mV}$ to $100\text{mV}$   |      | 15    |       | $\mu\text{s}$    |
| $I_{S^+(0)}, I_{S^-(0)}$ | Sense Input Current                           | $V_{SENSE} = 0\text{V}$   | ●    | 4.5   | 10    | $\mu\text{A}$    |
| $I_{CC(0)}$              | Supply Current                                | $V_{SENSE} = 0\text{V}$   | ●    | 60    | 145   | $\mu\text{A}$    |
| SR                       | Slew Rate (Note 8)                            | $V_{CC} = 15\text{V}$ , $V_{SENSE} = 26\text{mV}$ to $380\text{mV}$ , $A_V = 50\text{V/V}$                      | 0.03 | 0.05  |       | V/ $\mu\text{s}$ |
|                          |   |   | 0.02 | 0.05  |       | V/ $\mu\text{s}$ |
| $I_{SC}$                 | Short-Circuit Current                         | $I_{SC^+}, I_{SC^-}$  | 8    | 15    |       | mA               |
|                          | Reverse $V_S$ Supply                          | $I_{S(TOTAL)} = -200\mu\text{A}$ , $V_{CC} = \text{Open}$   | ●    | 50    | 60    | V                |
| $V_{O(MIN)}$             | Minimum Output Voltage                        | $V_{SENSE} = 0\text{V}$ , No Load   | ●    | 15    | 30    | mV               |
|                          |   | $V_{SENSE} = V_{S^+} - V_{S^-} = -100\text{mV}$ , $A_V = 50\text{V/V}$ , No Load                                |      | 15    | 25    | mV               |
| $V_{O(MAX)}$             | Output High (Referred to $V_{CC}$ )           | $A_V = 50\text{V/V}$ , $V_{SENSE} = 100\text{mV}$ , $I_L = 0$   | ●    | 75    | 125   | mV               |
|                          |   | $V_{SENSE} = 100\text{mV}$ , $I_L = 100\mu\text{A}$   | ●    | 85    | 150   | mV               |
|                          |   | $V_{SENSE} = 100\text{mV}$ , $I_L = 500\mu\text{A}$   | ●    | 125   | 250   | mV               |
|                          |   | $V_{SENSE} = 100\text{mV}$ , $I_L = 1\text{mA}$   | ●    | 175   | 400   | mV               |
| $I_{S^+}, I_{S^-}$ (Off) | Sense Input Current (Power Down)              | $V_{CC} = 0\text{V}$ , $V_S = 48\text{V}$ , $V_{SENSE} = 0\text{V}$   | ●    | 0.001 | 1     | $\mu\text{A}$    |

The ● denotes specifications which apply over the temperature range  $-40^{\circ}\text{C} \leq T_A \leq 125^{\circ}\text{C}$  (LT6100H), otherwise specifications are  $T_A = 25^{\circ}\text{C}$ .  $V_{CC} = 5\text{V}$ ,  $V_{EE} = 0\text{V}$ ,  $V_{S^+} = V_{CC} + 1.4\text{V}$  unless otherwise specified. (Note 5)

| SYMBOL             | PARAMETER                           | CONDITIONS  | MIN | TYP  | MAX      | UNITS                          |               |
|--------------------|-------------------------------------|---|-----|------|----------|--------------------------------|---------------|
| $V_{S^-}, V_{S^+}$ | Sense Amplifier Supply Voltage      | $V_{CC} = 2.7\text{V}$  | ●   | 4.1  | 48       | V                              |               |
| $V_{SENSE}$        | Input Sense Voltage Full Scale      | $V_{SENSE} = V_{S^+} - V_{S^-}$ , $V_{CC} = 3\text{V}$ , $A_V = 10\text{V/V}$ | ●   | 110  |          | mV                             |               |
|                    |                                     | $V_{SENSE} = V_{S^+} - V_{S^-}$ , $V_{CC} = 5\text{V}$ , $A_V = 10\text{V/V}$ | ●   | 300  |          | mV                             |               |
| $V_{OS}$           | Input Offset Voltage (MS Package)   | $I_{OUT} = 0$   | ●   | -300 | $\pm 80$ | 300                            | $\mu\text{V}$ |
|                    | Input Offset Voltage (DD Package)   | $I_{OUT} = 0$   | ●   | -600 | $\pm 80$ | 600                            | $\mu\text{V}$ |
| $V_{OS}$ TC        | Temperature Coefficient of $V_{OS}$ | (Note 6)  | ●   | -350 | $\pm 80$ | 350                            | $\mu\text{V}$ |
|                    |                                     |   | ●   | -650 | $\pm 80$ | 650                            | $\mu\text{V}$ |
|                    |                                     |   | ●   | 0.5  | 5        | $\mu\text{V}/^{\circ}\text{C}$ |               |

## ELECTRICAL CHARACTERISTICS

The ● denotes specifications which apply over the temperature range  $-40^{\circ}\text{C} \leq T_A \leq 125^{\circ}\text{C}$  (LT6100H), otherwise specifications are  $T_A = 25^{\circ}\text{C}$ .  $V_{CC} = 5\text{V}$ ,  $V_{EE} = 0\text{V}$ ,  $V_{S^+} = V_{CC} + 1.4\text{V}$  unless otherwise specified. (Note 5)

| SYMBOL                   | PARAMETER                                     | CONDITIONS  | MIN  | TYP   | MAX   | UNITS            |
|--------------------------|---|---|------|-------|-------|------------------|
| $A_V$                    | Gain, $V_{OUT}/V_{SENSE}$                     | $V_{SENSE} = 50\text{mV}$ to $80\text{mV}$ , $A_V = 10\text{V/V}$<br>LT6100MS8                                  | 9.95 |       | 10.05 | V/V              |
|                          |   | LT6100DD8   | 9.94 |       | 10.06 | V/V              |
|                          |   | $V_S = 48\text{V}$ , $V_{SENSE} = 50\text{mV}$ to $80\text{mV}$ , $A_V = 10\text{V/V}$                          | 9.90 |       | 10.10 | V/V              |
|                          | Output Voltage Gain Error (Note 7)            | $V_{SENSE} = 50\text{mV}$ to $80\text{mV}$ ,<br>$A_V = 10, 12.5, 20, 25, 40, 50\text{V/V}$<br>LT6100MS8         | -0.5 |       | 0.5   | %                |
|                          | LT6100DD8                                     | -0.6  |      | 0.6   | %     |                  |
|                          |   | $V_S = 48\text{V}$ , $V_{SENSE} = 50\text{mV}$ to $80\text{mV}$ ,<br>$A_V = 10, 12.5, 20, 25, 40, 50\text{V/V}$ | -1.0 |       | 1.0   | %                |
| $V_S$ CMRR               | $V_S$ Sense Input Common Mode Rejection Ratio | $V_{SENSE} = 50\text{mV}$ , $V_{CC} = 2.7\text{V}$ , $V_S = 4.1\text{V}$ to $36\text{V}$                        | 105  | 120   |       | dB               |
|                          |   |   | 100  | 120   |       | dB               |
| $V_{CC}$ PSRR            | $V_{CC}$ Supply Rejection Ratio               | $V_{SENSE} = 50\text{mV}$ , $V_S = 36\text{V}$ , $V_{CC} = 3\text{V}$ to $30\text{V}$                           | 105  | 120   |       | dB               |
|                          |   |   | 95   | 120   |       | dB               |
| $V_{CC}$                 | Supply Voltage $V_{CC}$                       |   | 2.7  |       | 36    | V                |
| BW                       | Bandwidth                                     | $A_V = 10\text{V/V}$ , $f_0 = -3\text{dB}$ , $V_{CC} = 15\text{V}$  | 100  | 150   |       | kHz              |
|                          |   | $A_V = 50\text{V/V}$ , $f_0 = -3\text{dB}$ , $V_{CC} = 15\text{V}$  | 20   | 50    |       | kHz              |
| $t_S$                    | Output Settling to 1% Final Value             | $V_{SENSE} = 10\text{mV}$ to $100\text{mV}$   |      | 15    |       | $\mu\text{s}$    |
| $I_{S^+(0)}, I_{S^-(0)}$ | Sense Input Current                           | $V_{SENSE} = 0\text{V}$   | ●    | 4.5   | 10    | $\mu\text{A}$    |
| $I_{CC(0)}$              | Supply Current                                | $V_{SENSE} = 0\text{V}$   | ●    | 60    | 170   | $\mu\text{A}$    |
| SR                       | Slew Rate (Note 8)                            | $V_{CC} = 15\text{V}$ , $V_{SENSE} = 26\text{mV}$ to $380\text{mV}$ , $A_V = 50\text{V/V}$                      | 0.03 | 0.05  |       | V/ $\mu\text{s}$ |
|                          |   |   | 0.02 | 0.05  |       | V/ $\mu\text{s}$ |
| $I_{SC}$                 | Short-Circuit Current                         | $I_{SC^+}, I_{SC^-}$  | 8    | 15    |       | mA               |
|                          | Reverse $V_S$ Supply                          | $I_{S(TOTAL)} = -200\mu\text{A}$ , $V_{CC} = \text{Open}$   | ●    | 50    | 60    | V                |
| $V_{O(MIN)}$             | Minimum Output Voltage                        | $V_{SENSE} = 0\text{V}$ , No Load   | ●    | 15    | 35    | mV               |
|                          |   | $V_{SENSE} = V_{S^+} - V_{S^-} = -100\text{mV}$ , $A_V = 50\text{V/V}$ , No Load                                |      | 15    | 25    | mV               |
| $V_{O(MAX)}$             | Output High (Referred to $V_{CC}$ )           | $A_V = 50\text{V/V}$ , $V_{SENSE} = 100\text{mV}$ , $I_L = 0$   | ●    | 75    | 140   | mV               |
|                          |   | $V_{SENSE} = 100\text{mV}$ , $I_L = 100\mu\text{A}$   | ●    | 85    | 160   | mV               |
|                          |   | $V_{SENSE} = 100\text{mV}$ , $I_L = 500\mu\text{A}$   | ●    | 125   | 250   | mV               |
|                          |   | $V_{SENSE} = 100\text{mV}$ , $I_L = 1\text{mA}$   | ●    | 175   | 400   | mV               |
| $I_{S^+}, I_{S^-}$ (Off) | Sense Input Current (Power Down)              | $V_{CC} = 0\text{V}$ , $V_S = 48\text{V}$ , $V_{SENSE} = 0\text{V}$   | ●    | 0.001 | 1     | $\mu\text{A}$    |

**Note 1:** Stresses beyond those listed under Absolute Maximum Ratings may cause permanent damage to the device. Exposure to any Absolute Maximum Rating condition for extended periods may affect device reliability and lifetime.

**Note 2:** ESD (Electrostatic Discharge) sensitive devices. Extensive use of ESD protection devices are used internal to the LT6100, however, high electrostatic discharge can damage or degrade the device. Use proper ESD handling precautions.

**Note 3:** A heat sink may be required to keep the junction temperature below absolute maximum ratings.

**Note 4:** The LT6100C/LT6100I are guaranteed functional over the operating temperature range of  $-40^{\circ}\text{C}$  to  $85^{\circ}\text{C}$ . The LT6100H is guaranteed functional over the operating temperature range of  $-40^{\circ}\text{C}$  to  $125^{\circ}\text{C}$ .

**Note 5:** The LT6100C is guaranteed to meet specified performance from  $0^{\circ}\text{C}$  to  $70^{\circ}\text{C}$ . The LT6100C is designed, characterized and expected to meet specified performance from  $-40^{\circ}\text{C}$  to  $85^{\circ}\text{C}$  but is not tested or QA sampled at these temperatures. The LT6100I is guaranteed to meet specified performance from  $-40^{\circ}\text{C}$  to  $85^{\circ}\text{C}$ . The LT6100H is guaranteed to meet specified performance from  $-40^{\circ}\text{C}$  to  $125^{\circ}\text{C}$ .

**Note 6:** This parameter is not 100% tested.

**Note 7:** Gain error for  $A_V = 12.5, 25\text{V/V}$  is guaranteed by the other gain error tests.

**Note 8:** Slew rate is measured on the output between  $3.5\text{V}$  and  $13.5\text{V}$ .

TYPICAL PERFORMANCE CHARACTERISTICS

Input Offset Voltage vs Temperature

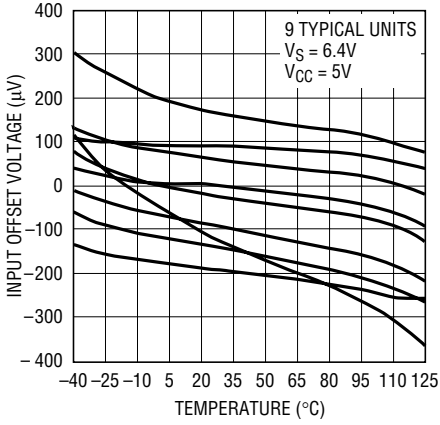

6100 G21

Input Offset Voltage vs VS+ Input Voltage

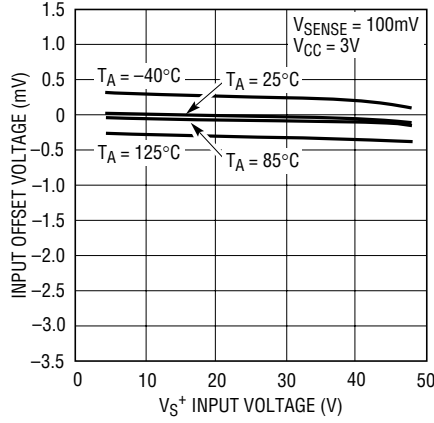

6100 G01

Input Offset Voltage vs VCC Supply Voltage

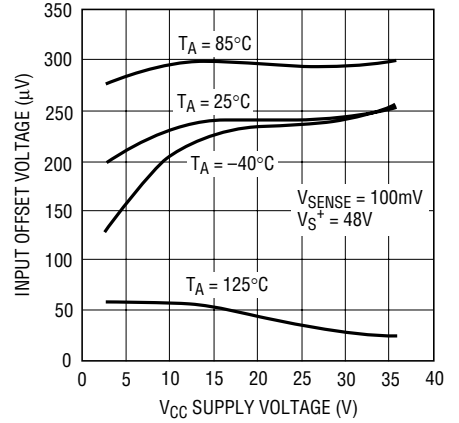

6100 G02

Output Voltage vs Sense Voltage

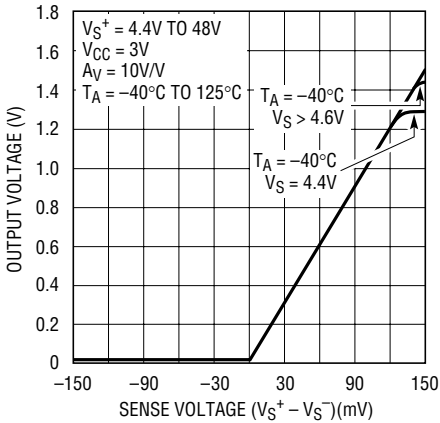

6100 G03

Output Voltage vs Sense Voltage

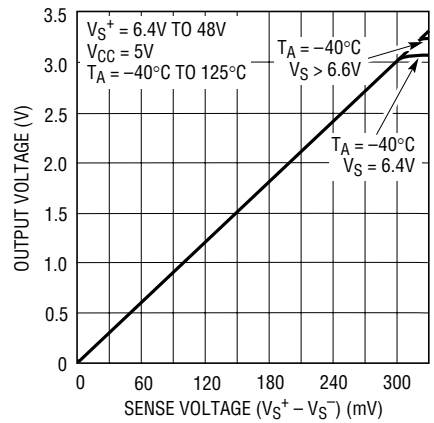

6100 G04

Gain vs Temperature

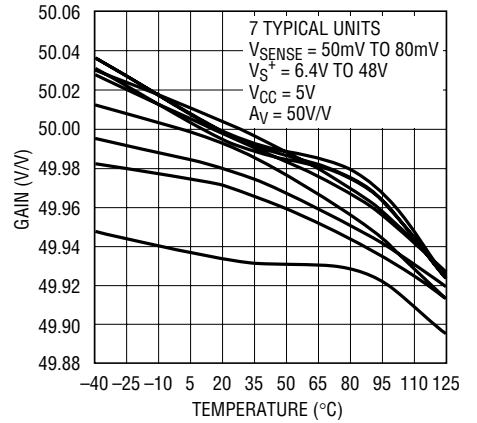

6100 G05

Negative Sense Input Current vs Sense Voltage

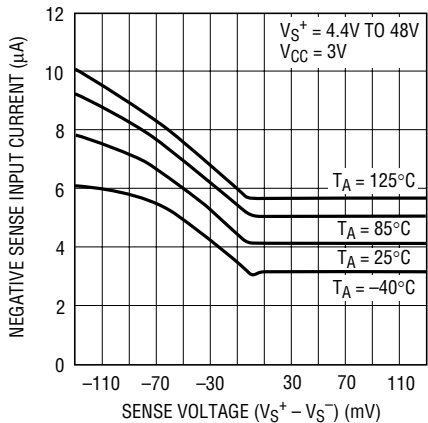

6100 G06

Positive Sense Input Current vs Sense Voltage

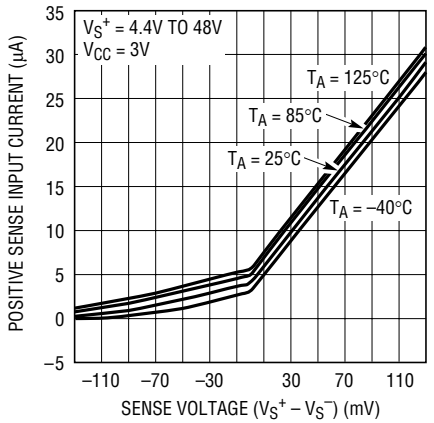

6100 G07

Output Positive Swing vs Load Current

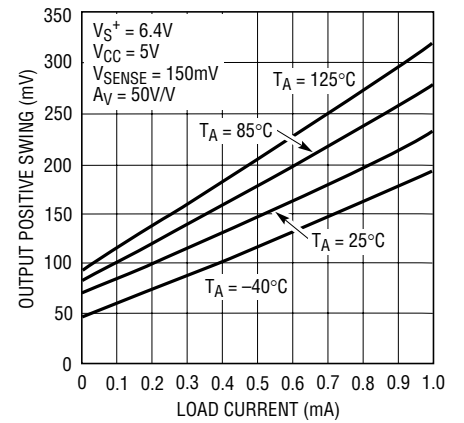

6100 G08

# TYPICAL PERFORMANCE CHARACTERISTICS

**V<sub>CC</sub> Supply Current vs V<sub>S</sub> Input Voltage**

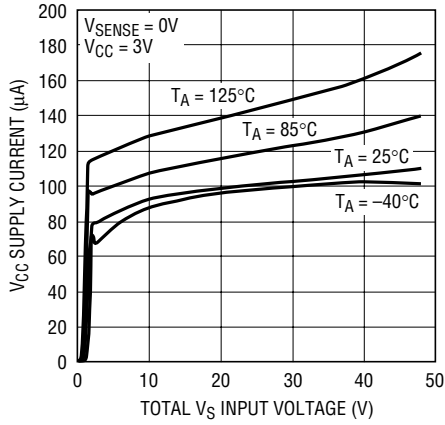

**Op Amp Output Impedance vs Frequency**

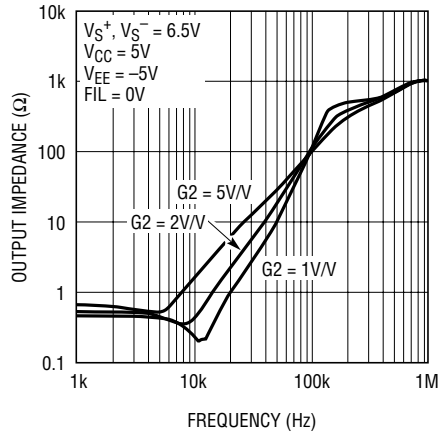

**Gain vs Frequency**

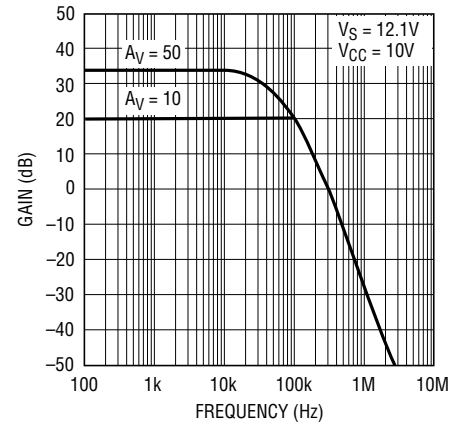

**CMRR vs Frequency**

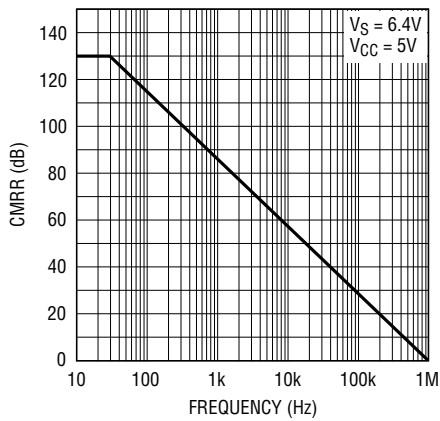

**V<sub>CC</sub> PSRR vs Frequency**

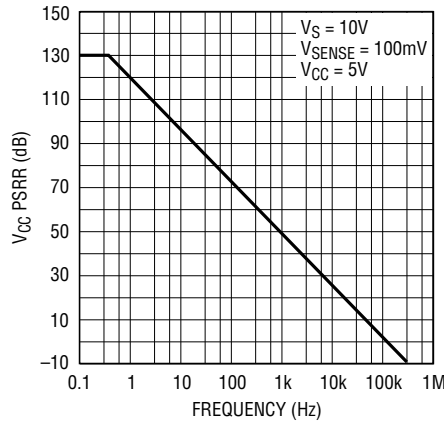

**Gain Error vs VSENSE**

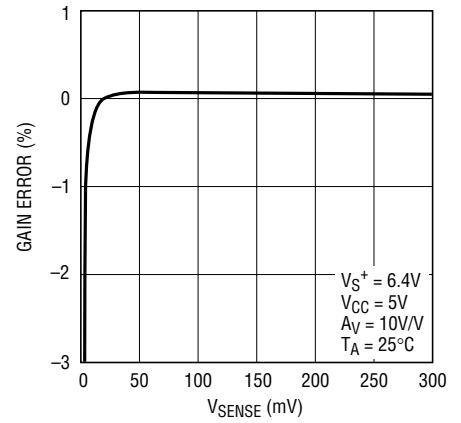

**Sense Input Current (V<sub>CC</sub> Powered Down) vs VS+**

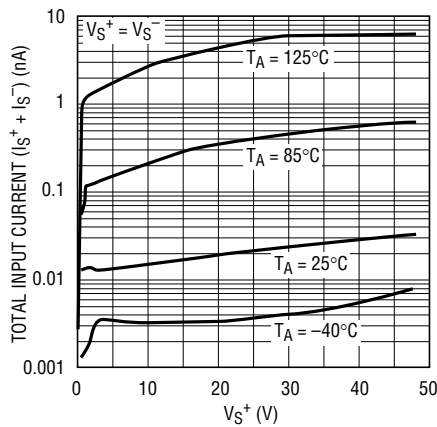

**Step Response at VSENSE = 0V to 130mV**

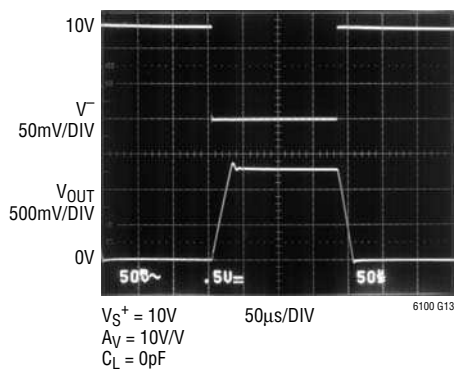

**Step Response at VSENSE = 0V to 130mV**

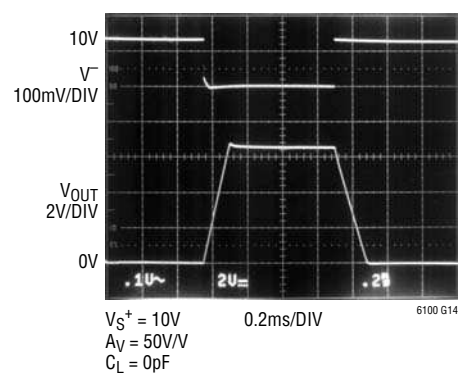

# TYPICAL PERFORMANCE CHARACTERISTICS

Step Response at  $V_{SENSE} = 0V$  to  $10mV$

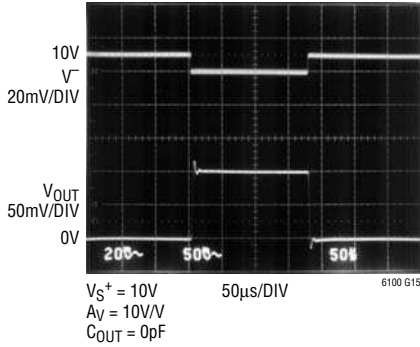

Step Response at  $V_{SENSE} = 0V$  to  $10mV$

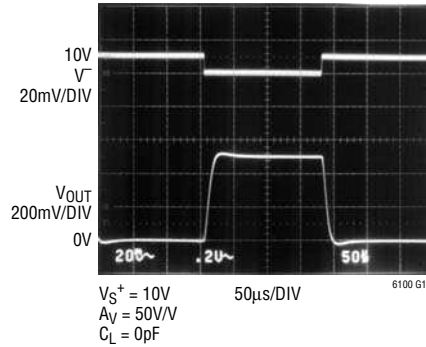

Step Response at  $V_{SENSE} = 0V$  to  $130mV$

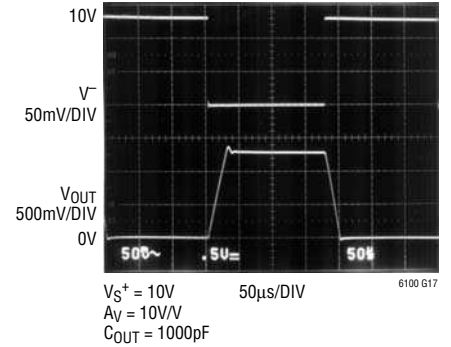

Step Response at  $V_{SENSE} = 0V$  to  $130mV$

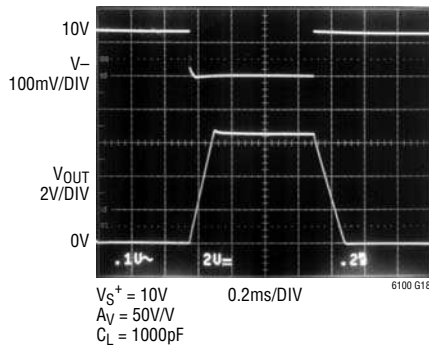

Step Response at  $V_{SENSE} = 0V$  to  $10mV$

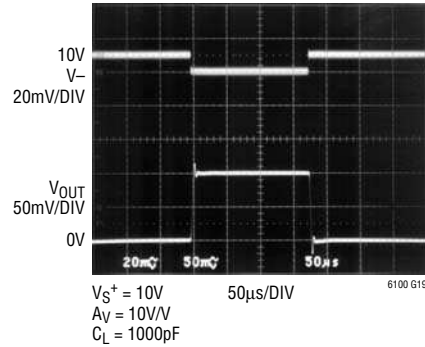

Step Response at  $V_{SENSE} = 0V$  to  $10mV$

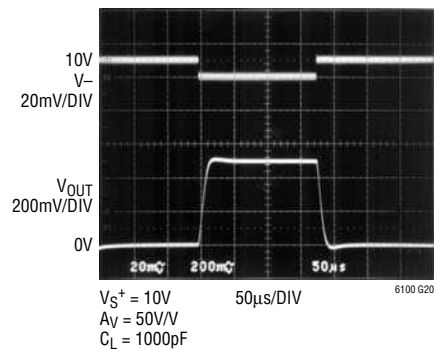

Start-Up Delay

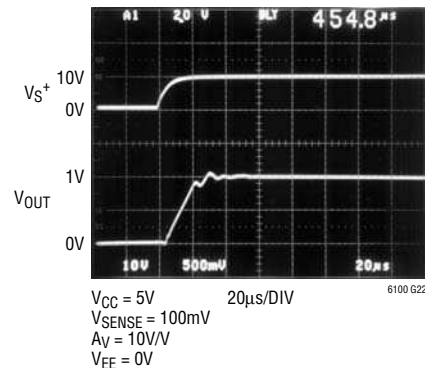

## PIN FUNCTIONS

**V<sub>S</sub><sup>-</sup> (Pin 1):** Negative Sense Input Terminal. Negative sense voltage input will remain functional for voltages up to 48V. V<sub>S</sub><sup>-</sup> is connected to an internal gain-setting resistor R<sub>G1</sub> = 5k.

**V<sub>CC</sub> (Pin 2):** Supply Voltage Input. This power supply pin supplies current to both current sense amplifier and op amp.

**FIL (Pin 3):** Filter Pin. Connects to an external capacitor to roll off differential noise of the system. Pole frequency  $f_{-3dB} = 1/(2\pi R_{FIL}C)$ , R<sub>FIL</sub> = R<sub>E</sub> + R<sub>O</sub> = 60k.

**V<sub>EE</sub> (Pin 4):** Negative Supply or Ground for Single Supply Operation.

**V<sub>OUT</sub> (Pin 5):** Voltage Output Proportional to the Magnitude of the Current Flowing Through R<sub>SENSE</sub>:

$$V_{OUT} = A_V \cdot (V_{SENSE} \pm V_{OS})$$

V<sub>OS</sub> is the input offset voltage. A<sub>V</sub> is the total gain of the LT6100.

**A2 (Pin 6):** Gain Select Pin. Refer to Table 1.

**A4 (Pin 7):** Gain Select Pin. When Pin 7 is shorted to V<sub>EE</sub>, the total gain is 40V/V. When both Pin 6 and Pin 7 are shorted to V<sub>EE</sub>, the total gain is 50V/V. When both Pin 6 and Pin 7 are opened, the total gain is 10V/V.

**V<sub>S</sub><sup>+</sup> (Pin 8):** Positive Sense Input Terminal. Connecting a supply to V<sub>S</sub><sup>+</sup> and a load to V<sub>S</sub><sup>-</sup> will allow the LT6100 to monitor the current through R<sub>SENSE</sub>, refer to Figure 1. V<sub>S</sub><sup>+</sup> is connected to an internal gain setting resistor R<sub>G2</sub> = 5k. V<sub>S</sub><sup>+</sup> remains functional for voltages up to 48V.

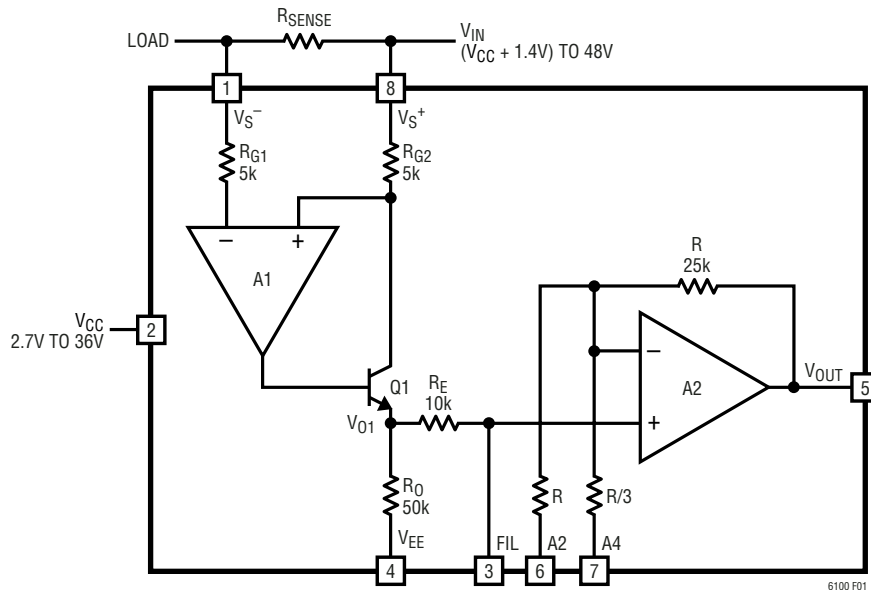

Figure 1. Functional Diagram

## APPLICATIONS INFORMATION

The LT6100 high side current sense amplifier (Figure 1) provides accurate unidirectional monitoring of current through a user-selected sense resistor. The LT6100 features a fully specified 4.1V to 48V input common mode range. A high PSRR  $V_{CC}$  supply (2.7V to 36V) powers the current sense amplifier and the internal op amp circuitry. The input sense voltage is level shifted from the positive sense power supply to the ground reference and amplified by a user-selected gain to the output. The buffered output voltage is directly proportional to the current flowing through the sense resistor.

### Theory of Operation (Refer to Figure 1)

Current from the source at  $V_S^+$  flows through  $R_{SENSE}$  to the load at  $V_S^-$ , creating a sense voltage,  $V_{SENSE}$ . Inputs  $V_S^+$  and  $V_S^-$  apply the sense voltage to  $R_{G2}$ . The opposite ends of resistors  $R_{G1}$  and  $R_{G2}$  are forced to be at equal potentials by the voltage gain of amplifier A1. The current through  $R_{G2}$  is forced to flow through transistor Q1 and is sourced to node  $V_{O1}$ . The current from  $R_{G2}$  flowing through resistor  $R_O$  gives a voltage gain of ten,  $V_{O1}/V_{SENSE} = R_O/R_{G2} = 10V/V$ . The sense amplifier output at  $V_{O1}$  is amplified again by amplifier A2. The inputs of amplifier A2 can operate to ground which ensures that small sense voltage signals are detected. Amplifier A2 can be programmed to different gains via Pin 6 and Pin 7. Thus, the total gain of the system becomes  $A_V = 10 \cdot A_2$  and  $V_{OUT} = V_{SENSE} \cdot A_V$ .

### Gain Setting

The LT6100 gain is set by strapping (or floating) the two gain pins (see Table 1). This feature allows the user to “zoom in” by increasing the gain for accurate measurement of low currents.

$A_V = 10V/V \cdot G_2$ ,  $G_2$  is the gain of op amp A2.

**Table 1. Gain Set with Pin 6 and Pin 7**

| A2 (PIN 6) | A4 (PIN 7) | G2   | $A_V$ |
|------------|------------|------|-------|
| Open       | Open       | 1    | 10    |
| $V_{EE}$   | Out        | 1.25 | 12.5  |
| $V_{EE}$   | Open       | 2    | 20    |
| Out        | $V_{EE}$   | 2.5  | 25    |
| Open       | $V_{EE}$   | 4    | 40    |
| $V_{EE}$   | $V_{EE}$   | 5    | 50    |

### Selection of External Current Sense Resistor

External  $R_{SENSE}$  resistor selection is a delicate trade-off between power dissipation in the resistor and current measurement accuracy. The maximum sense voltage may be as large as  $\pm 300mV$  to get maximum dynamic range. For high current applications, the user may want to minimize the sense voltage to minimize the power dissipation in the sense resistor. The LT6100’s low input offset voltage of  $80\mu V$  allows for high resolution of low sense voltages. This allows limiting the maximum sense voltage while still providing high resolution current monitoring.

Kelvin connection of the LT6100’s  $V_S^+$  and  $V_S^-$  inputs to the sense resistor should be used to provide the highest accuracy in high current applications. Solder connections and PC board interconnect resistance (approximately  $0.5m\Omega$  per square) can be a large error in high current systems. A 5A application might choose a  $20m\Omega$  sense resistor to give a  $100mV$  full-scale input to the LT6100. Input offset voltage will limit resolution to 4mA. Neglecting contact resistance at solder joints, even one square of PC board copper at each resistor end will cause an error of 5%. This error will grow proportionately higher as monitored current levels rise.

## APPLICATIONS INFORMATION

### Noise Filtering

The LT6100 provides signal filtering via pin FIL that is internally connected to the resistors  $R_E$  and  $R_O$ . This pin may be used to filter the input signal entering the LT6100's internal op amp, and should be used when fast ripple current or transients flow through the sense resistor. High frequency signals above the 300kHz bandwidth of the LT6100's internal amplifier will cause errors. A capacitor connected between FIL and  $V_{EE}$  creates a single pole low pass filter with corner frequency:

$$f_{-3dB} = 1/(2\pi R_{FIL}C)$$

where  $R_{FIL} = 60k$ . A 220pF capacitor creates a pole at 12kHz, a good choice for many applications.

### Output Signal Range

The LT6100's output signal is developed by current through  $R_{G2}$  into output resistor  $R_O$ . The current is  $V_{SENSE}/R_{G2}$ . The sense amplifier output,  $V_{O1}$ , is buffered by the internal op amp so that connecting the output pins to other systems will preserve signal accuracy. For zero  $V_{SENSE}$ , internal circuit saturation with loss of accuracy occurs at the minimum  $V_{OUT}$  swing, 15mV above  $V_{EE}$ .  $V_{OUT}$  may swing positive to within 0.75V of  $V_{CC}$  or a maximum of 36V, a limit set by internal junction breakdown. Within

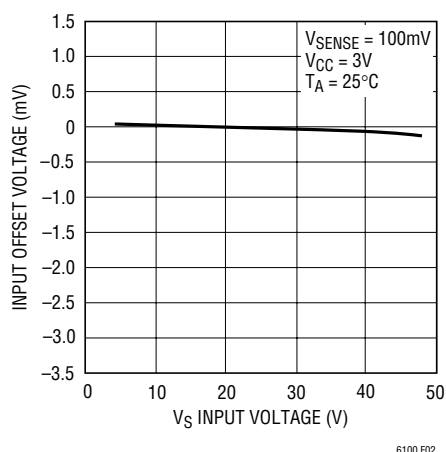

Figure 2.  $V_{OS}$  vs  $V_S$  Input Voltage

these constraints, an amplified, level shifted representation of the  $R_{SENSE}$  voltage is developed at  $V_{OUT}$ . The output is well behaved driving capacitive loads to 1000pF.

### Sense Input Signal Range

The LT6100 has high CMRR over the wide input voltage range of 4.1V to 48V. The minimum operation voltage of the sense amplifier input is 1.4V above  $V_{CC}$ . The output remains accurate even when the sense inputs are driven to 48V. Figure 2 shows that  $V_{OS}$  changes very slightly over a wide input range. Furthermore, the sense inputs  $V_S^+$  and  $V_S^-$  can collapse to zero volts without incurring any damage to the device. The LT6100 can handle differential sense voltages up to the voltage of the sense inputs supplies. For example,  $V_S^+ = 48V$  and  $V_S^- = 0V$  can be a valid condition in a current monitoring application (Figure 3) when an overload protection fuse is blown and  $V_S^-$  voltage collapses to ground. Under this condition, the output of the LT6100 goes to the positive rail,  $V_{OH}$ . There is no phase inversion to cause an erroneous output signal. For the opposite case when  $V_S^+$  collapse to ground with  $V_S^-$  held up at some higher voltage potential, the output will sit at  $V_{OL}$ . If both inputs fall below the minimum CM voltage,  $V_{CC} + 1.4V$ , the output is indeterminate but the LT6100 will not be damaged.

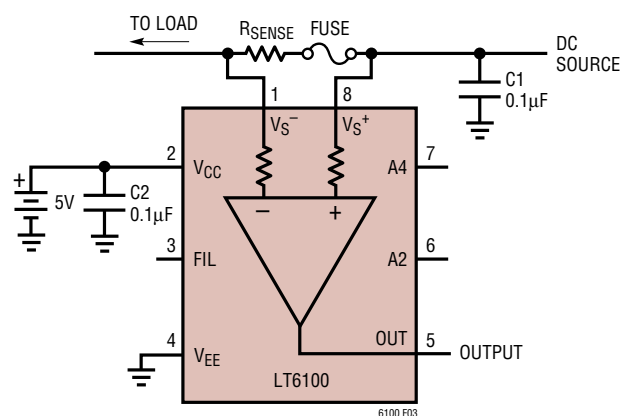

Figure 3. Current Monitoring of a Fuse Protected Circuit

## APPLICATIONS INFORMATION

### Low Sense Voltage Operation

Figure 4 shows the simplest circuit configuration in which the LT6100 may be used. While  $V_{OUT}$  (output voltage) increases with positive sense current, at  $V_{SENSE} = 0V$ , the LT6100's buffered output can only swing as low

as  $V_{OL} = 15mV$ . The accuracy at small sense voltages can be improved by selecting higher gain. When gain of  $50V/V$  is selected, as shown in Figure 7,  $V_{OUT}$  leaves the clipped region for a positive  $V_{SENSE}$  greater than  $1mV$  compared to  $2.5mV$  for gain of  $10V/V$  (see Figure 6).

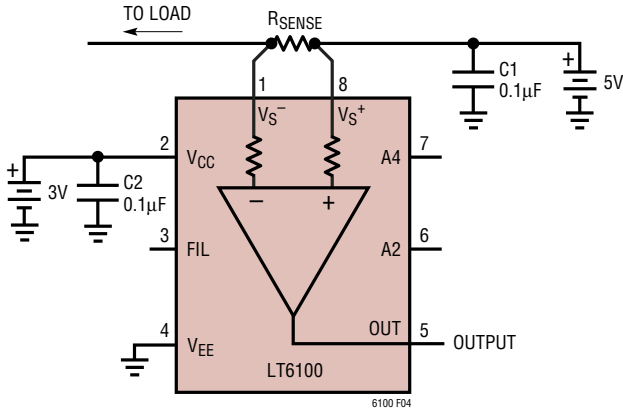

Figure 4. LT6100 Load Current Monitor

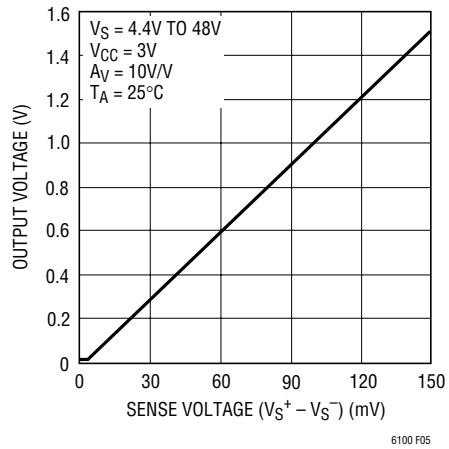

Figure 5. Output Voltage vs  $V_{SENSE}$

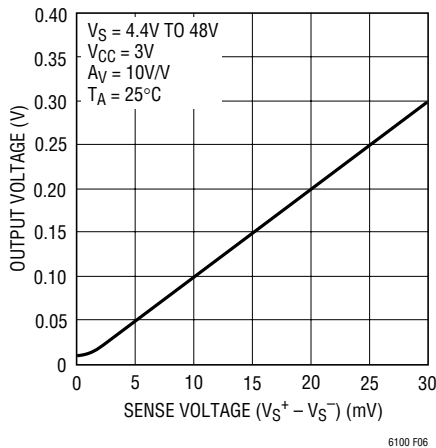

Figure 6. Expanded View of Output Voltage vs  $V_{SENSE}$ ,  $A_V = 10V/V$

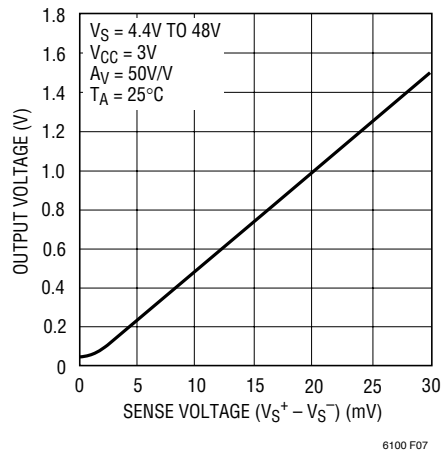

Figure 7. Expanded View of Output Voltage vs  $V_{SENSE}$ ,  $A_V = 50V/V$

## APPLICATIONS INFORMATION

### Power Down While Connected to a Battery

Another unique benefit of the LT6100 is that you can leave it connected to a battery even when it is denied power. When the LT6100 loses power or is intentionally powered down, its inputs remain high impedance (see Figure 8).

This is due to the implementation of Linear Technology's Over-The-Top<sup>®</sup> input topology at its front end. When powered down, the LT6100 inputs draw less than 1 $\mu$ A of current.

Over-The-Top is a registered trademark of Linear Technology Corporation.

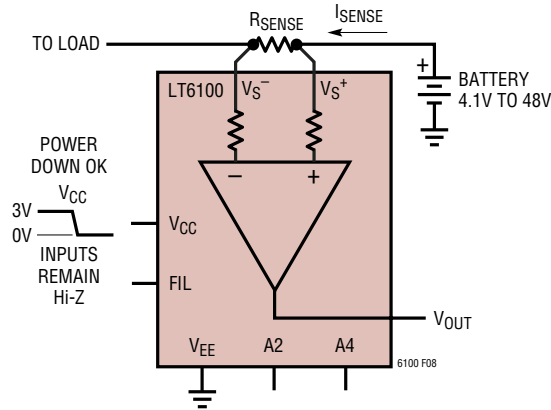
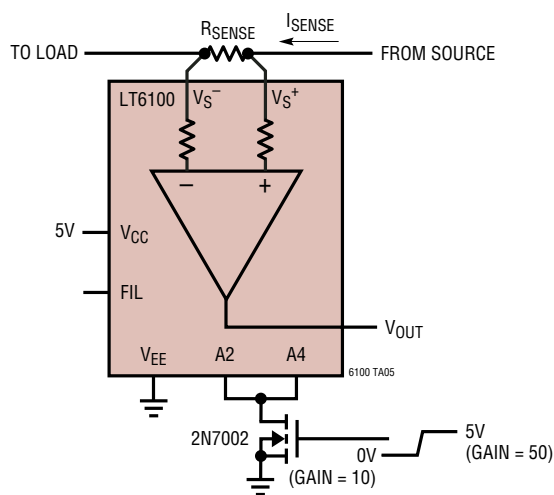

Figure 8. Input Remains Hi-Z when LT6100 is Powered Down

## TYPICAL APPLICATION

### Adjust Gain Dynamically for Enhanced Range



### Micro-Hotplate Voltage and Current Monitor

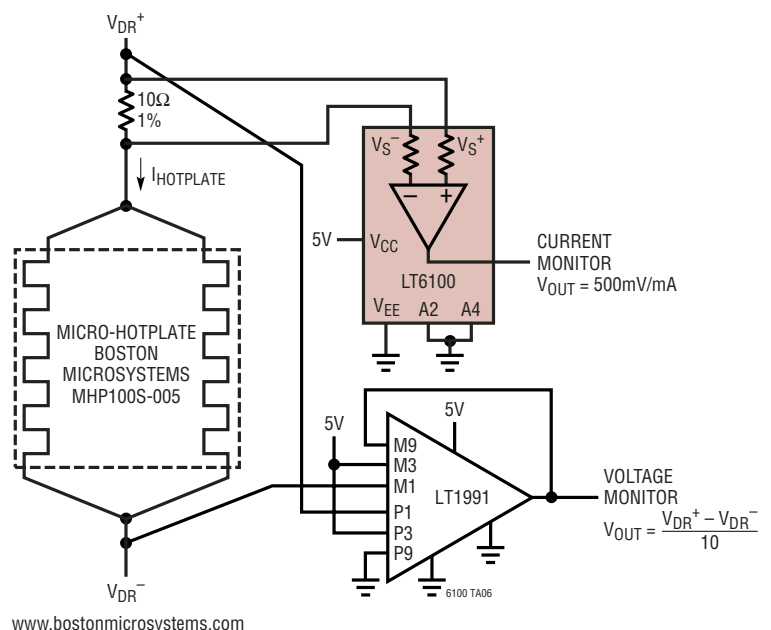

www.bostonmicrosystems.com

**PACKAGE DESCRIPTION**

**DD Package**  
**8-Lead Plastic DFN (3mm × 3mm)**  
 (Reference LTC DWG # 05-08-1698)

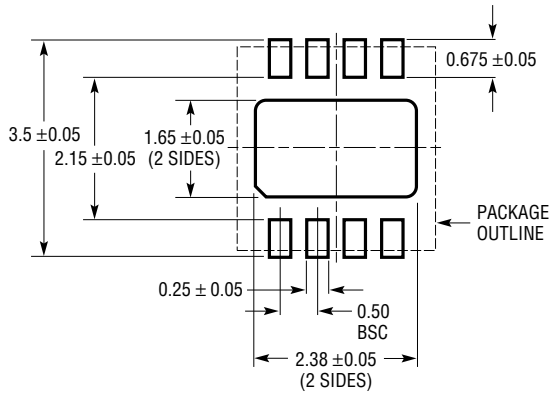

RECOMMENDED SOLDER PAD PITCH AND DIMENSIONS

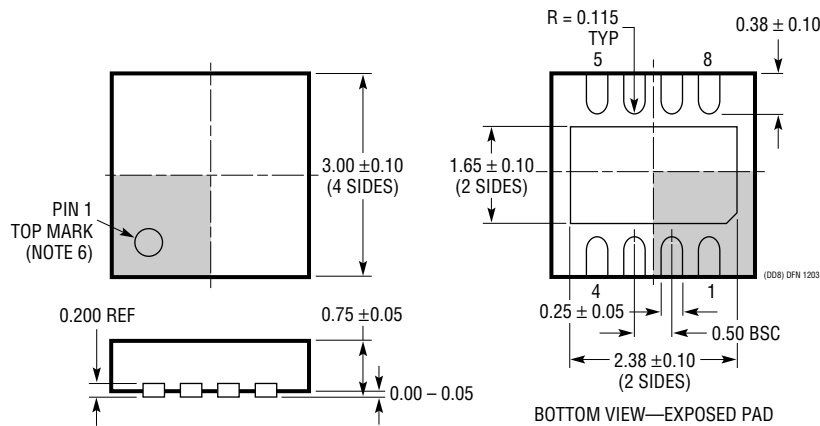

- NOTE:
1. DRAWING TO BE MADE A JEDEC PACKAGE OUTLINE M0-229 VARIATION OF (WEED-1)
  2. DRAWING NOT TO SCALE
  3. ALL DIMENSIONS ARE IN MILLIMETERS
  4. DIMENSIONS OF EXPOSED PAD ON BOTTOM OF PACKAGE DO NOT INCLUDE MOLD FLASH. MOLD FLASH, IF PRESENT, SHALL NOT EXCEED 0.15mm ON ANY SIDE
  5. EXPOSED PAD SHALL BE SOLDER PLATED
  6. SHADED AREA IS ONLY A REFERENCE FOR PIN 1 LOCATION ON TOP AND BOTTOM OF PACKAGE

# PACKAGE DESCRIPTION

## MS8 Package 8-Lead Plastic MSOP (Reference LTC DWG # 05-08-1660)

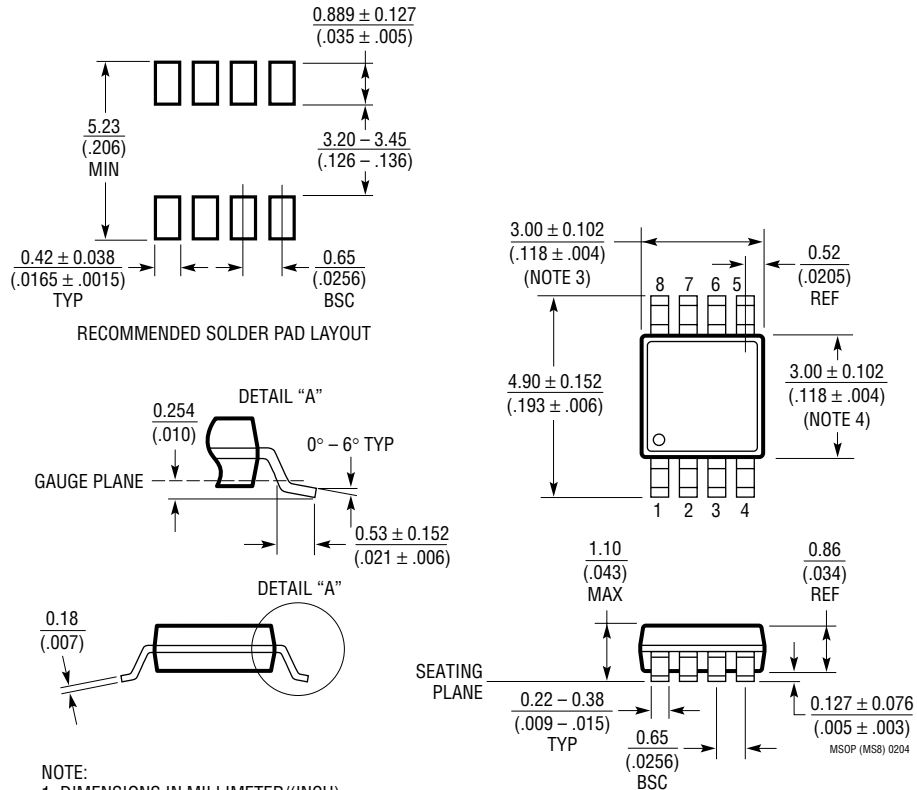

**NOTE:**

1. DIMENSIONS IN MILLIMETER/(INCH)
2. DRAWING NOT TO SCALE
3. DIMENSION DOES NOT INCLUDE MOLD FLASH, PROTRUSIONS OR GATE BURRS.  
MOLD FLASH, PROTRUSIONS OR GATE BURRS SHALL NOT EXCEED 0.152mm (.006") PER SIDE
4. DIMENSION DOES NOT INCLUDE INTERLEAD FLASH OR PROTRUSIONS.  
INTERLEAD FLASH OR PROTRUSIONS SHALL NOT EXCEED 0.152mm (.006") PER SIDE
5. LEAD COPLANARITY (BOTTOM OF LEADS AFTER FORMING) SHALL BE 0.102mm (.004") MAX

**TYPICAL APPLICATIONS**

**800mA/1A White LED Current Regulator**

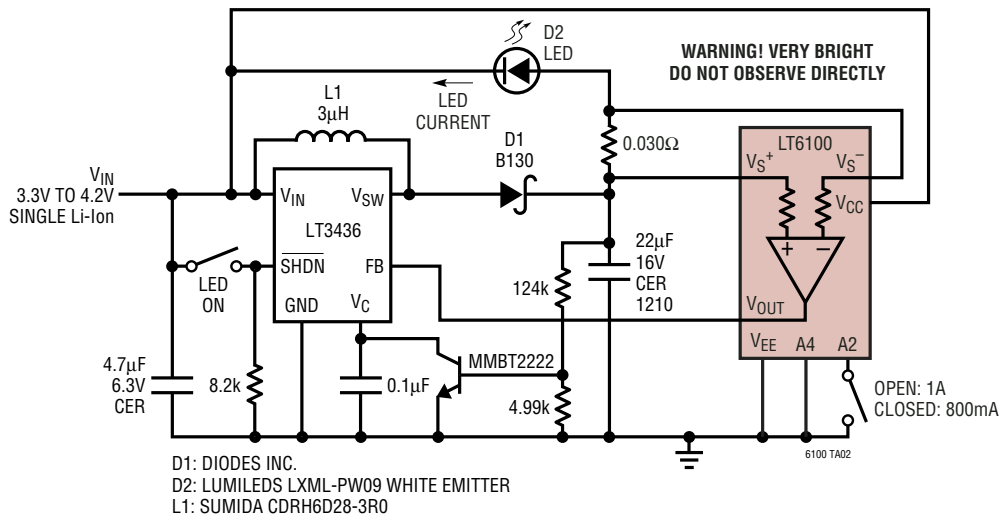

**Filtered Gain of 20 Current Sense**

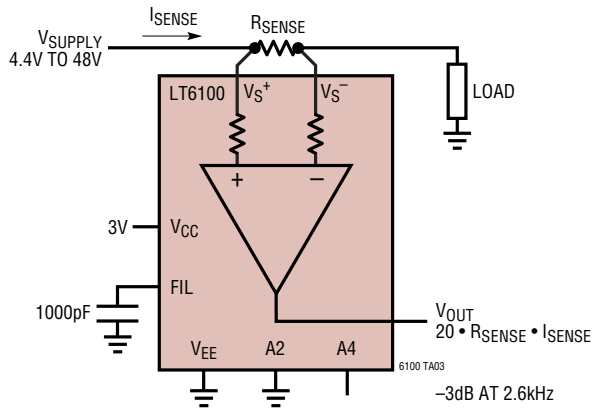

**Gain of 50 Current Sense**

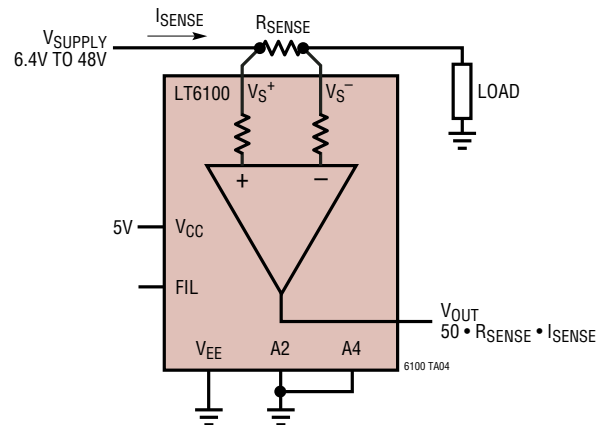

**RELATED PARTS**

| PART NUMBER       | DESCRIPTION  | COMMENTS   |
|-------------------|--|--|
| LTC1043           | Dual Precision Instrumentation Switched Capacitor Building Block | 120dB CMRR, 3V to 18V Operation                                  |
| LT1490/LT1491     | Dual and Quad Micropower Rail-to-Rail Input and Output Op Amps   | 50 $\mu$ A Amplifier, 2.7V to 40V Operation, Over-The-Top Inputs |
| LT1620/LT1621     | Rail-to-Rail Current Sense Amplifiers                            | Accurate Output Current Programming, Battery Charging to 32V     |
| LT1787            | Precision Bidirectional, High Side Current Sense Amplifier       | 75 $\mu$ V $V_{OS}$ , 60V, 60 $\mu$ A Operation                  |
| LTC6101/LTC6101HV | High Voltage, High Side, Precision Current Sense Amplifiers      | 4V to 60V/5V to 100V, Gain Configurable, SOT-23                  |