

1MHz/500kHz Continuous Time, Low Noise, Lowpass Elliptic Filter

FEATURES

- 5th Order, 1MHz Elliptic Filter in SO-8 Package
- Pin Selectable 1MHz/500kHz Cutoff Frequency
- Signal-to-Noise Ratio (SNR): 75dB
- Signal-to-Noise Ratio with -63dB THD: 69dB
- Passband Ripple ($f_{CUTOFF} = 1\text{MHz}$): $\pm 0.3\text{dB}$
- Stopband Attenuation Better Than 60dB
- No External Components Required

APPLICATIONS

- Antialiasing Filters
- Smoothing or Reconstruction Filters
- Communication Filters

DESCRIPTION

The LTC[®]1560-1 is a 5th order, continuous-time, lowpass filter. *The elliptic transfer function of the LTC1560-1 was carefully chosen to reach a compromise between selectivity, for antialiasing applications, and transient response.* The filter cutoff frequency, f_{CUTOFF} , is pin selectable to

either 500kHz (Pin 5 to V^+) or 1MHz (Pin 5 to V^-). When programmed for 1MHz, the passband ripple is typically $\pm 0.2\text{dB}$ up to $0.55f_{CUTOFF}$ and $\pm 0.3\text{dB}$ to $0.9f_{CUTOFF}$. The transition band gain is -24dB at $1.4f_{CUTOFF}$ and -51dB at $2f_{CUTOFF}$. Stopband attenuation is 63dB at $2.43f_{CUTOFF}$ and above, remaining at least 60dB to 10MHz with proper board layout. When the LTC1560-1 is programmed for $f_{CUTOFF} = 500\text{kHz}$, the filter response closely follows the 1MHz case with the exception of passband flatness near the cutoff frequency; the gain at f_{CUTOFF} is -1.3dB .

The LTC1560-1, unlike other high frequency filters, is designed for low noise and low distortion. With a $1V_{RMS}$ input signal, the signal-to-noise ratio is 69dB and the THD is -63dB . The maximum SNR of 75dB is obtained with a $2.1V_{RMS}$ input signal. This results in -46dB THD.

The LTC1560-1 operates with $\pm 5\text{V}$ supplies, has a power saving mode and is available in an SO-8 surface mount package.

Other cutoff frequencies from 450kHz to 1.5MHz can be obtained. Demo board DC135A is available for the LTC1560-1. For more information please contact LTC Marketing.

 LTC and LT are registered trademarks of Linear Technology Corporation.

TYPICAL APPLICATION

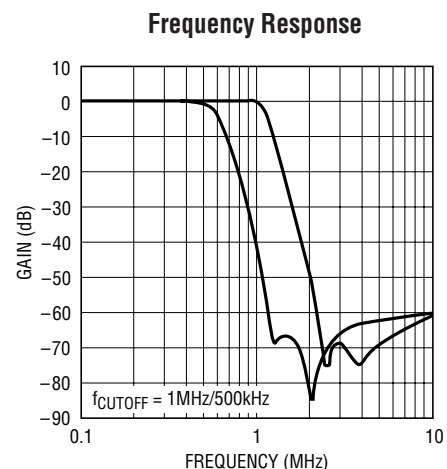
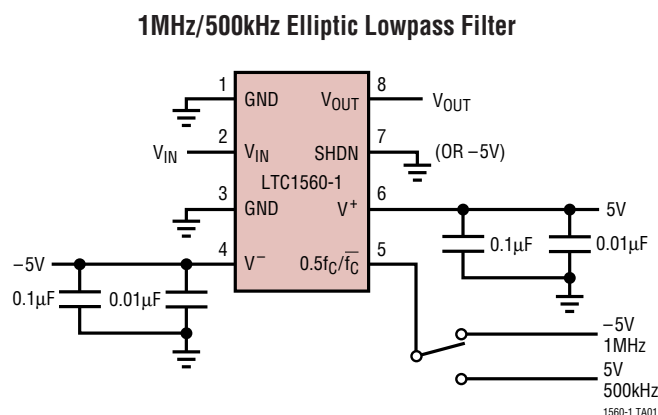

ABSOLUTE MAXIMUM RATINGS

Total Supply Voltage (V^+ to V^-) 12V
 Power Dissipation 400mW
 Burn-In Voltage $\pm 5.5V$
 Operating Temperature Range
 LTC1560-1C $0^\circ C$ to $70^\circ C$
 LTC1560-1I $-40^\circ C$ to $85^\circ C$
 Maximum Junction Temperature $150^\circ C$
 Storage Temperature Range $-65^\circ C$ to $150^\circ C$
 Lead Temperature (Soldering, 10 sec) $300^\circ C$

PACKAGE/ORDER INFORMATION

<p>S8 PACKAGE 8-LEAD PLASTIC SO $T_{JMAX} = 150^\circ C, \theta_{JA} = 125^\circ C/W$</p>	ORDER PART NUMBER
	LTC1560-1CS8 LTC1560-1IS8
	S8 PART MARKING
	15601 15601I

Consult factory for Military grade parts.

ELECTRICAL CHARACTERISTICS

$V_S = \pm 5V, T_A = 25^\circ C, Pin\ 5 = -5V (f_{CUTOFF} = 1MHz), Pin\ 7 = 0V$ unless otherwise specified.

PARAMETER	CONDITIONS	MIN	TYP	MAX	UNITS	
Operating Supply Voltage Range		± 4.5	± 5.0	± 5.5	V	
Passband Gain ($f_{CUTOFF} = 1MHz$)	$V_{IN} = 0.5V_{RMS}, f_{IN} = 20kHz$ $f_{IN} = 100kHz$ $f_{IN} = 300kHz$ $f_{IN} = 550kHz$ (Gain Relative to 100kHz) $f_{IN} = 850kHz$ (Gain Relative to 100kHz) $f_{IN} = 950kHz$ (Gain Relative to 100kHz) $f_{IN} = f_{CUTOFF} = 1MHz$ (Gain Relative to 100kHz)	● ● ● ● ● ●	0.17 0.18 0.08 0.05 -0.3 0.6	0.6 0.3 0 0.5 1.0	dB dB dB dB dB dB	
Transition Band Gain (Note 1)	$V_{IN} = 0.5V_{RMS}, f_{IN} = 1.4MHz$ $f_{IN} = 1.9MHz$ $f_{IN} = 2.0MHz$	●	-24 -42 -51	-18	dB dB dB	
Stopband Gain ($f_{CUTOFF} = 1MHz$) (Note 2)	$f_{IN} = 2.44MHz$ $f_{IN} = 3.0MHz$ $f_{IN} = 6.0MHz$	●	-70 -68 -66.1	-65	dB dB dB	
Passband Gain ($f_{CUTOFF} = 500kHz$)	$f_{IN} = 100kHz, Pin\ 5 = 5V$ $f_{IN} = f_{CUTOFF} = 500kHz$ $f_{IN} = 1.4MHz$	●	-4 -1.6 -45	0.5	dB dB dB	
Output Voltage Swing	$R_L = 5k$ $R_L = 5k$	●	± 2.20 ± 1.75	± 3	V V	
Output DC Offset (V_{OS})			± 250		mV	
Power Supply Current (I_S)		●	22	29	mA	
Power Supply Current in Shutdown Mode	Pin 7 at 5V		1		mA	
Total Output Noise	V_{IN} (Pin 2) Tied to Ground, $f_{CUTOFF} = 1MHz, BW = 2MHz$ V_{IN} (Pin 2) Tied to Ground, $f_{CUTOFF} = 0.5MHz, BW = 1MHz$		350 322		μV_{RMS} μV_{RMS}	
Total Harmonic Distortion (THD)	$V_{IN} = 1V_{RMS}, f_{IN} = 200kHz, f_{CUTOFF} = 1MHz, BW = 1MHz$ $f_{IN} = 300kHz, f_{CUTOFF} = 1MHz, BW = 1MHz$ $f_{IN} = 1MHz, f_{CUTOFF} = 1MHz, BW = 2MHz$		-63 -61 -62		dB dB dB	
	$f_{IN} = 300kHz, f_{CUTOFF} = 0.5MHz, BW = 1MHz$ $f_{IN} = 500kHz, f_{CUTOFF} = 0.5MHz, BW = 1MHz$		-62 -63		dB dB	
Input Resistance (R_{IN})		●	6	8	10	k Ω

The ● denotes specifications which apply over the full operating temperature range.

Note 1: To properly measure high frequency characteristics of the filter, a noninverting output buffer is recommended as shown on the demo board

connection diagram, Figure 2. A small resistor (e.g. 100 Ω) can also be used instead of the buffer to isolate any high capacitive load ($C_L > 10pF$) from the filter output.

Note 2: The stopband gain at 2.44MHz is guaranteed by design.

TYPICAL PERFORMANCE CHARACTERISTICS

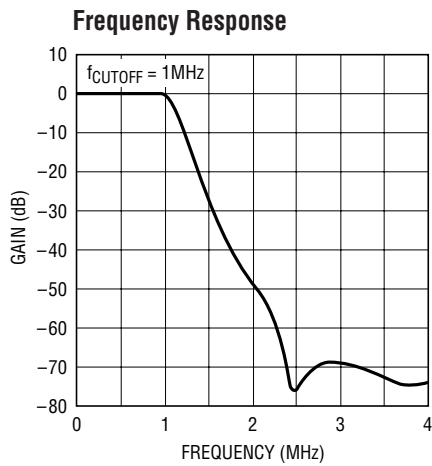

1560-1 G01

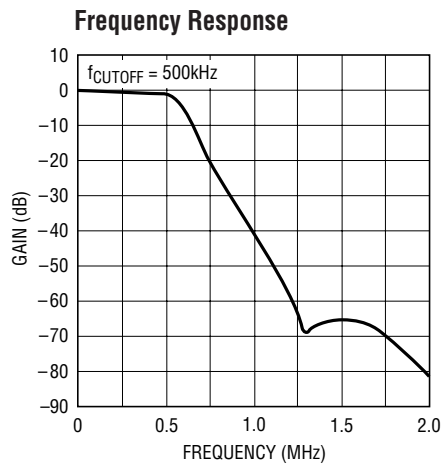

1560-1 G02

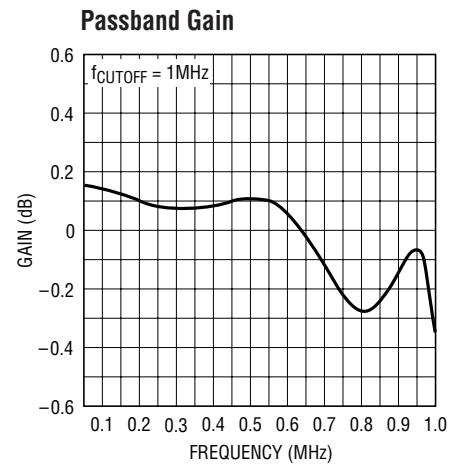

1560-1 G03

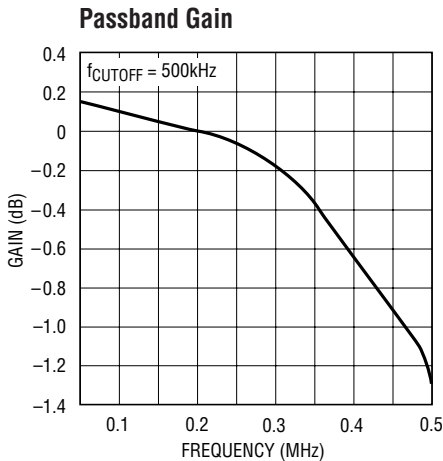

1560-1 G04

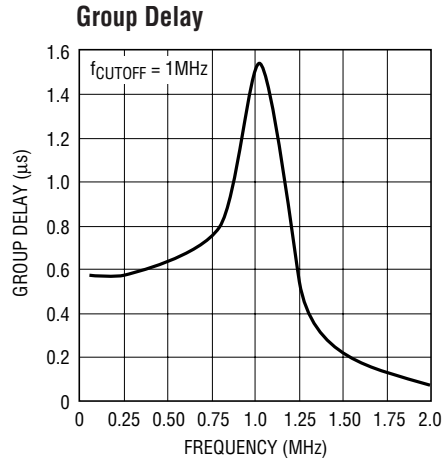

1560-1 G05

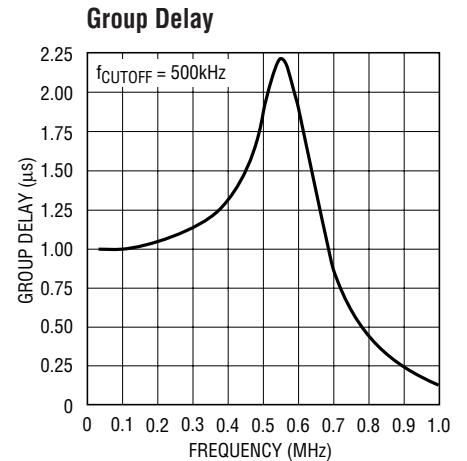

1560-1 G06

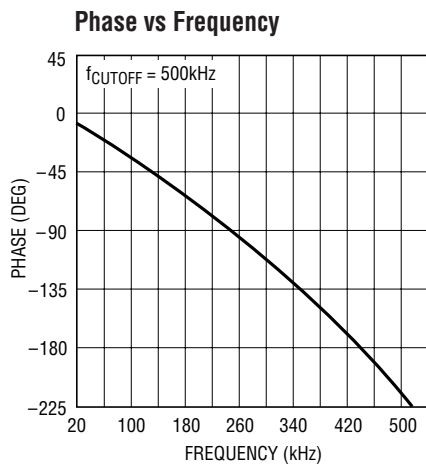

1560-1 G07

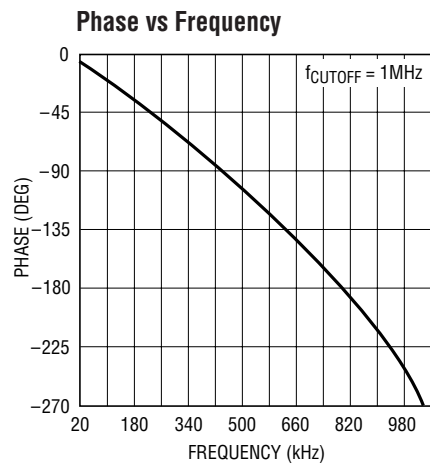

1560-1 G08

TYPICAL PERFORMANCE CHARACTERISTICS

Transient Response

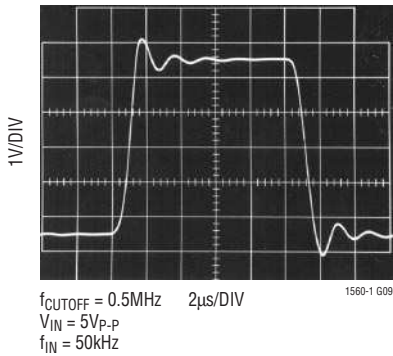

Transient Response

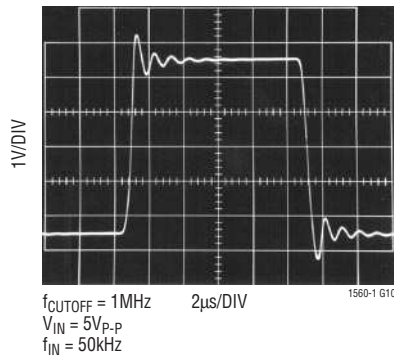

Output Noise vs Frequency

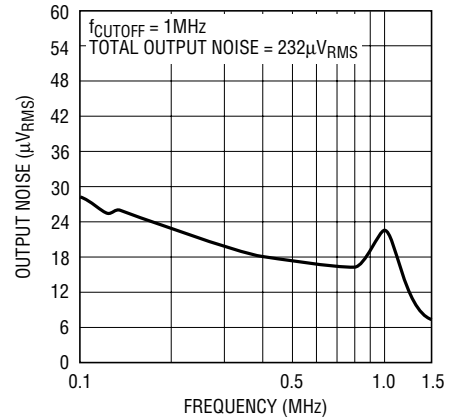

Output Noise vs Frequency

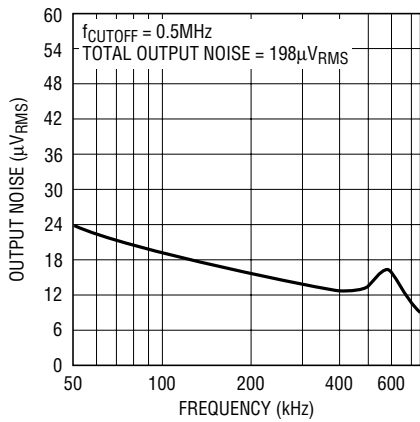

Dynamic Range

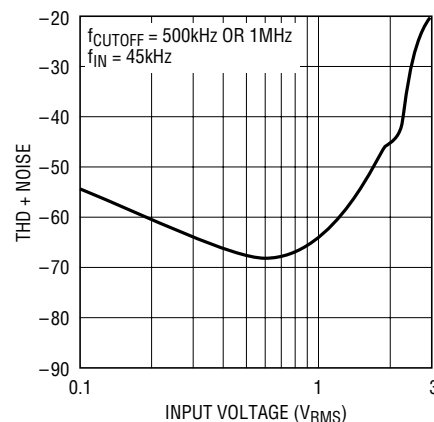

THD + Noise vs Input Frequency

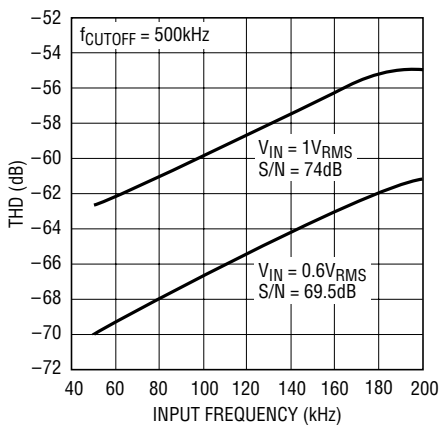

THD + Noise vs Input Frequency

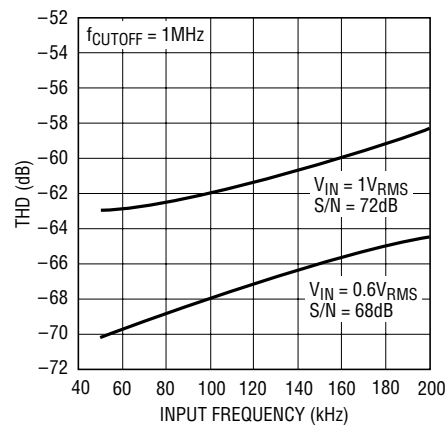

PIN FUNCTIONS

GND (Pins 1, 3): Analog Ground Pins. The quality of the analog ground can affect the filter performance. For dual supply operation the analog ground pin should be connected to an analog ground plane surrounding the package. The analog ground plane should be connected to a digital ground plane (if any) at a single point. For single supply operation, the analog ground pin should be biased at one-half the power supply across the device (see Figure 1) and the analog ground plane should then be connected to V^- (Pin 4).

V_{IN} (Pin 2): The filter input is internally connected to the inverting input of a high frequency op amp through an 8k resistor.

V^- , V^+ (Pins 4, 6): Power Supply Pins. The negative and positive power supply (Pins 4 and 6 respectively) should be decoupled with a $0.1\mu\text{F}$ capacitor in parallel with a $0.01\mu\text{F}$. Both capacitors should be types designed for decoupling video frequencies and they should be placed as close as possible to the power supply pins of the filter. Parallel routing of high frequency signal paths should be avoided; they will couple into the device's power supply pins and cause gain inaccuracy and stopband degradation.

The power supplies can be applied in any order, that is, the positive supply can be applied before the negative supply and vice versa. Switching power supplies are not recommended.

$0.5f_c/\bar{f}_c$ (Pin 5): By tying Pin 5 high the filter cutoff frequency is internally programmed for 500kHz. By tying Pin 5 low the cutoff frequency will switch to 1MHz. Pin 5 should not be left floating. The logic threshold of Pin 5 is approximately 0.4 times the total power supply across the device.

SHDN (Pin 7): Shutdown. Under normal operating conditions, Pin 7 should be shorted either to the analog ground (Pin 1) or to V^- (Pin 4). If Pin 7 is pulled high to V^+ , the filter operation will stop and the IC will be placed in a power saving mode. The power supply current will then be reduced to 1mA. For a $\pm 5\text{V}$ supply, the logic threshold of Pin 7 is 2.5V. Pin 7 is internally connected to the analog ground pin via a 50k resistor.

V_{OUT} (Pin 8): The filter output pin can sink or source 1mA. The total harmonic distortion of the filter will degrade when driving coaxial cables or loads less than 10k without an output buffer.

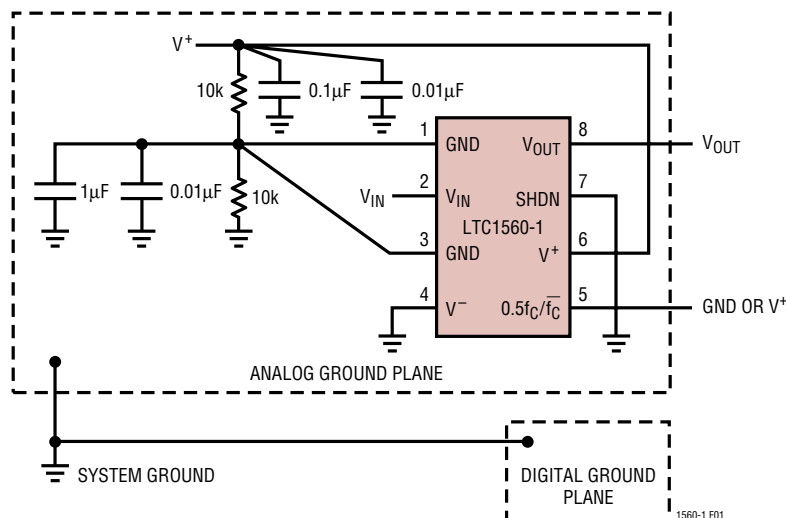

Figure 1. Connections for Single Supply Operation

APPLICATIONS INFORMATION

The performance of the LTC1560-1 can be easily evaluated by using demo board 135A which can be obtained through LTC marketing. Figure 2 shows the circuit connection of the LTC1560-1 in demo board 135A. The filter cutoff frequency can be switched via S2 and the power savings

mode can also be activated via S1. The output of the filter is buffered by U2, an LT[®]1360 op amp. The buffering can be bypassed by using jumper JP1. Figure 3 shows the demo board layout.

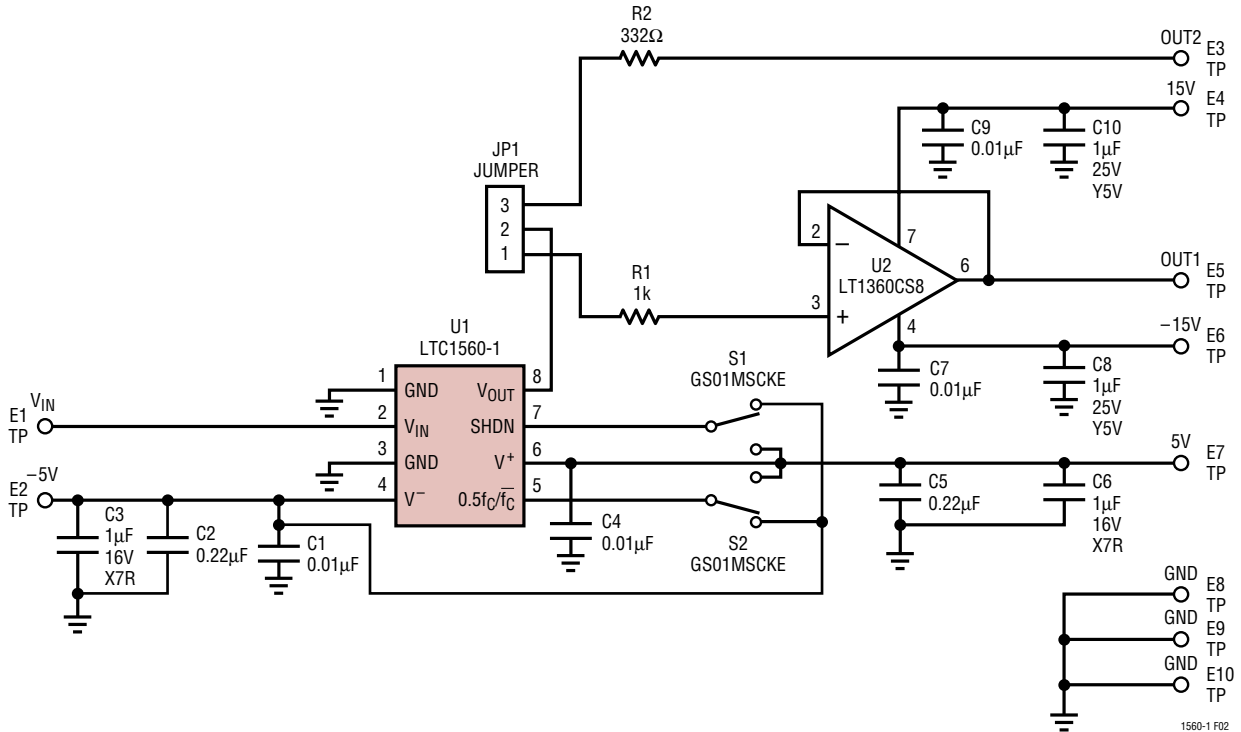

Figure 2. Demo Board 135A Connection Diagram

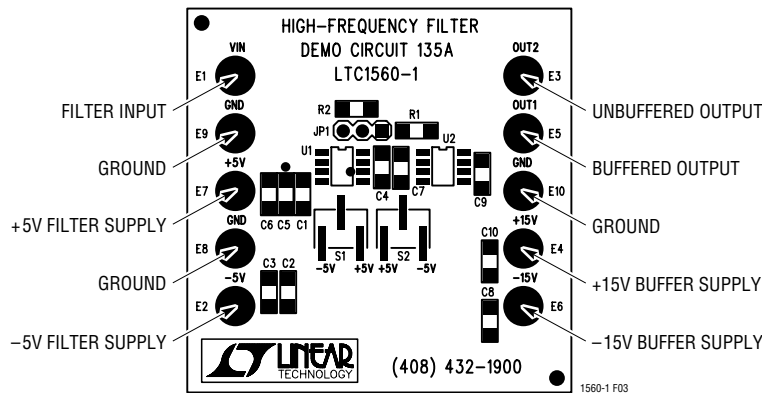
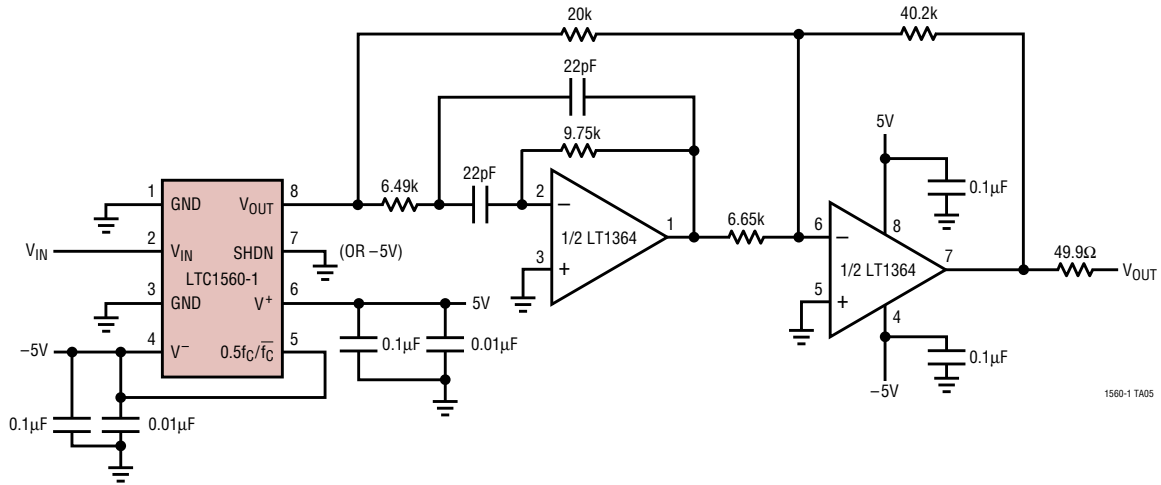

Figure 3. Demo Board 135A Layout

TYPICAL APPLICATIONS

Augmenting the LTC1560-1 for Improved Delay Flatness



2-Level Eye Diagram of the Equalized Filter

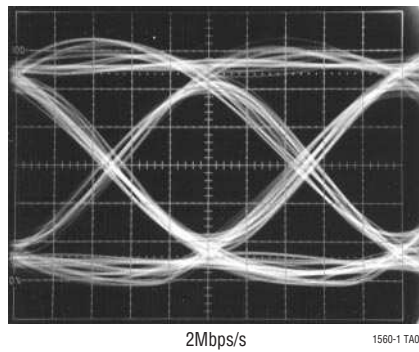

1MHz Lowpass Filter Cascaded with a 30kHz 3rd Order Highpass Filter

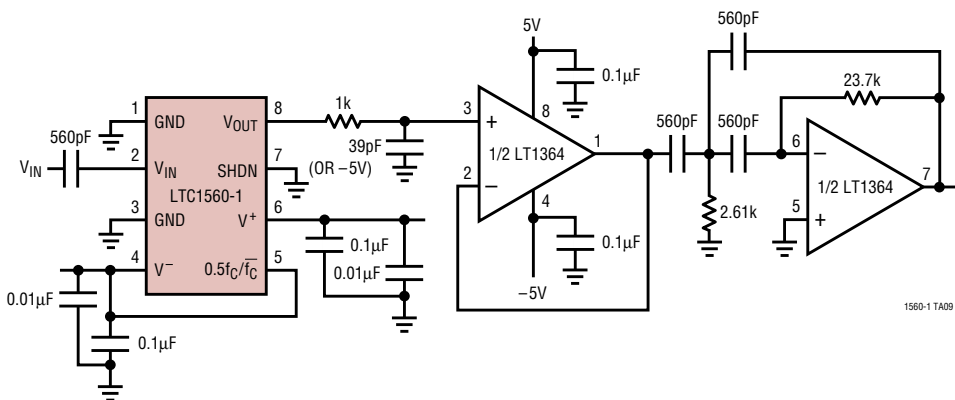

Gain vs Frequency

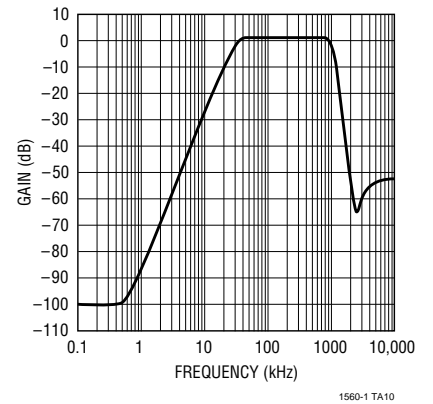

LTC1560-1

TYPICAL APPLICATION

A Simple Highpass/Lowpass Filter

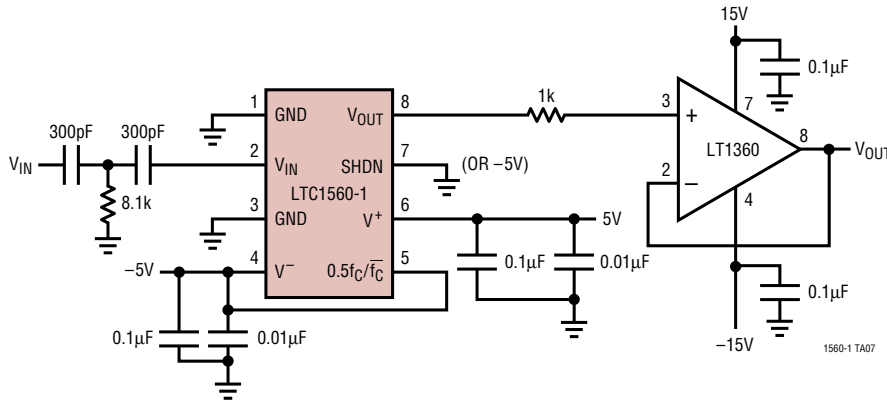

Measured Frequency Response

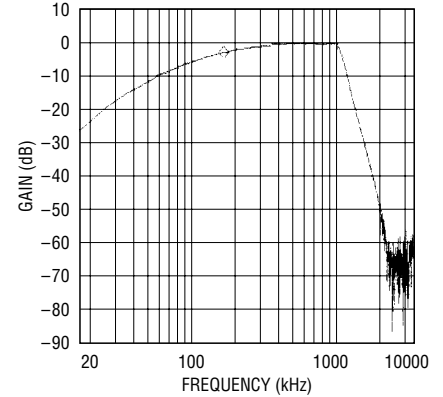

PACKAGE DESCRIPTION Dimensions in inches (millimeters) unless otherwise noted.

S8 Package
8-Lead Plastic Small Outline (Narrow 0.150)
 (LTC DWG # 05-08-1610)

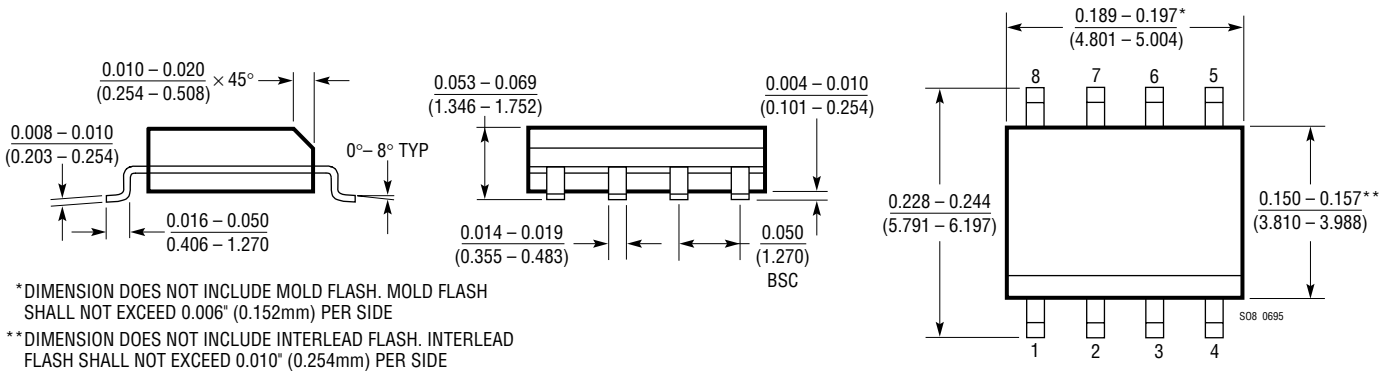

RELATED PARTS

PART NUMBER	DESCRIPTION	COMMENTS
LT1360/LT1361/ LT1362	50MHz, 800V/ μ s Op Amp(s)	Single/Dual/Quad C-Load™ Op Amps
LTC1562	Active RC Quad Universal Filter	Very Low Noise, Low Distortion

C-Load is a trademark of Linear Technology Corporation