

1A High Voltage, Efficiency Switching Voltage Regulator

FEATURES

- Wide Input Voltage Range: 3V to 75V
- High Switch Voltage: 100V
- Low Quiescent Current: 4.5mA
- Internal 1A Switch
- Shutdown Mode Draws Only 120 μ A Supply Current
- Isolated Flyback Regulation Mode for Fully Floating Outputs
- Can Be Externally Synchronized
- Available in MiniDIP and TO-220 Packages
- Same Pinout as LT1072

APPLICATIONS

- Telecom 5V Supply at 0.7A from -48V
- 90V Supply at 120mA from 15V
- All Applications Using LT1072 (See Below for Specification Differences)

LT1082 and LT1072 Major Specification Differences

	LT1082C	LT1072HV
V_{IN}	3V to 75V	3V to 60V
V_{SW}	100V	75V
Switch Current Limit	1A	1.25A
Quiescent Current	4.5mA	6mA
Operating Frequency	60kHz	40kHz
Flyback Reference Voltage	$16.2 + 0.6 (35k\Omega/R_{FB})$	$16 + 0.35 (7k\Omega/R_{FB})$

USER NOTE: This data sheet is only intended to provide specifications, graphs, and a general functional description of the LT1082. Application circuits are included to show the capability of the LT1082. A complete design manual (AN19) and Switcher CAD (LTC Switching Power Supply Design Program) should be obtained to assist in developing new designs. This manual contains a comprehensive discussion of both the LT1070 and the external components used with it, as well as complete formulas for calculating the values of these components. The manual can also be used for the LT1082 by factoring in the lower switch current rating.

DESCRIPTION

The LT[®]1082 is a monolithic high voltage switching regulator. It can be operated in all standard switching configurations including buck, boost, flyback, forward, and inverting. A 1A high efficiency switch is included on the die along with all oscillator, control, and protection circuitry.

The LT1082 operates with supply voltages from 3V to 75V, switch voltage up to 100V and draws only 4.5mA quiescent current. It can deliver load power up to 20W with no external power devices. By utilizing current-mode switching techniques, it provides excellent AC and DC load and line regulation.

An externally activated shutdown mode reduces total supply current to 120 μ A typical for standby operation. Totally isolated and regulated outputs can be generated by using the optional "isolated flyback regulation mode" built into the LT1082, without the need for optocouplers or extra transformer windings.

The LT1082 has a unique feature to provide high voltage short-circuit protection. When the FB pin is pulled down to 0.6V and the current out of the pin reaches approximately 350 μ A, the switching frequency will shift down from 60kHz to 12kHz.

The LT1082 is nearly identical to the lower voltage LT1072. For the major differences in specifications, see the table on the left.

 , LTC and LT are registered trademarks of Linear Technology Corporation

TYPICAL APPLICATION

Negative-to-Positive Telecom 5V Supply

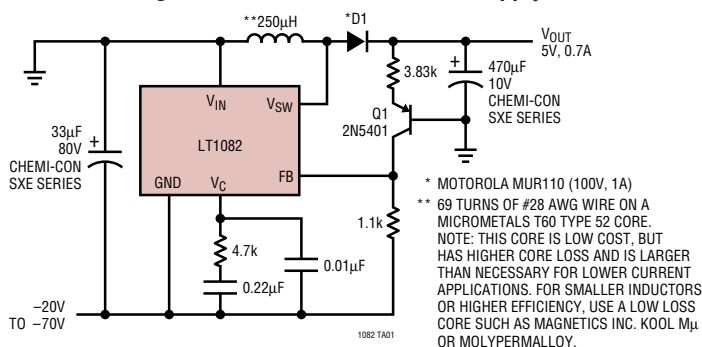

Telecom 5V Supply Maximum Output Current vs Input Voltage

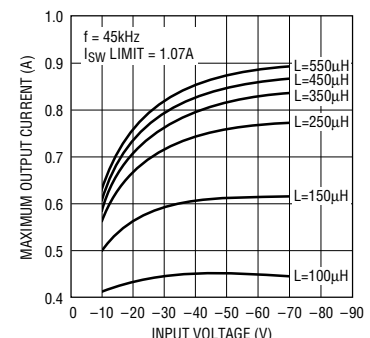

ABSOLUTE MAXIMUM RATINGS (Note 1)

Supply Voltage	75V	Operating Junction Temperature Range	
Switch Output Voltage	100V	LT1082M (OBSOLETE)	-55°C to 150°C
Feedback Pin Voltage (Transient, 1ms)	±15V	LT1082I	-40°C to 125°C
Storage Temperature Range	-65°C to 150°C	LT1082C	0°C to 100°C
Lead Temperature (Soldering, 10 sec).....	300°C		

PACKAGE/ORDER INFORMATION

<p>TOP VIEW</p> <p>N8 PACKAGE 8-LEAD PLASTIC DIP</p> <p>$T_{JMAX} = 100^{\circ}C, \theta_{JA} = 90^{\circ}C/W$ (CN8) $T_{JMAX} = 125^{\circ}C, \theta_{JA} = 90^{\circ}C/W$ (IN8)</p>	<p>FRONT VIEW</p> <p>Q PACKAGE 5-LEAD DD</p> <p>$T_{JMAX} = 100^{\circ}C, \theta_{JA} = 40^{\circ}C/W$ (CQ) $T_{JMAX} = 125^{\circ}C, \theta_{JA} = 40^{\circ}C/W$ (IQ)</p> <p>NOTE: θ_{JA} VARIES FROM 25°C/W TO 50°C/W DEPENDING ON BOARD COMPOSITION.</p>	<p>FRONT VIEW</p> <p>T PACKAGE 5-LEAD TO-220</p> <p>$T_{JMAX} = 100^{\circ}C, \theta_{JA} = 75^{\circ}C/W, \theta_{JC} = 8^{\circ}C/W$ (CT) $T_{JMAX} = 125^{\circ}C, \theta_{JA} = 75^{\circ}C/W, \theta_{JC} = 8^{\circ}C/W$ (IT)</p>
ORDER PART NUMBER	ORDER PART NUMBER	ORDER PART NUMBER
LT1082CN8 LT1082IN8	LT1082CQ LT1082IQ	LT1082CT LT1082IT
<p>J8 PACKAGE 8-LEAD CERAMIC DIP</p> <p>$T_{JMAX} = 150^{\circ}C, \theta_{JA} = 100^{\circ}C/W$ (MJ8)</p> <p>LT1082MJ8</p> <p>OBSOLETE PACKAGE Consider the Q Package for Alternate Source</p>		

Consult LTC Marketing for parts specified with wider operating temperature ranges.

ELECTRICAL CHARACTERISTICS

The ● denotes the specifications which apply over the full operating temperature range, otherwise specifications are at $T_A = 25^{\circ}C$. $V_{IN} = 15V$, $V_C = 0.5V$, $V_{FB} = V_{REF}$, output pin open, unless otherwise specified.

SYMBOL	PARAMETER	CONDITIONS	MIN	TYP	MAX	UNITS
V_{REF}	Reference Voltage	Measured at Feedback Pin $V_C = 0.8V$	1.224	1.244	1.264	V
			1.214	1.244	1.274	V
I_B	Feedback Input Current	$V_{FB} = V_{REF}$	350	750	1100	nA
						nA
g_m	Error Amplifier Transconductance	$\Delta I_C = \pm 25\mu A$	3000	4400	6000	μmho
			2400		7000	μmho
	Error Amplifier Source or Sink Current	$V_C = 1.5V$	150	200	400	μA
			120		400	μA
	Error Amplifier Clamp Voltage	Hi Clamp, $V_{FB} = 1V$ Lo Clamp, $V_{FB} = 1.5V$	1.8		2.3	V
			0.12	0.22	0.36	V
	Reference Voltage Line Regulation	$3V \leq V_{IN} \leq V_{MAX}, V_C = 0.8V$			0.03	%/V
A_V	Error Amplifier Voltage Gain	$0.9V \leq V_C \leq 1.4V$	350	650		V/V
						V
	Minimum Input Voltage		2.6	3.0		V

sn1082 1082fas

ELECTRICAL CHARACTERISTICS The ● denotes the specifications which apply over the full operating temperature range, otherwise specifications are at $T_A = 25^\circ\text{C}$. $V_{IN} = 15\text{V}$, $V_C = 0.5\text{V}$, $V_{FB} = V_{REF}$, output pin open, unless otherwise specified.

SYMBOL	PARAMETER	CONDITIONS	MIN	TYP	MAX	UNITS	
I_Q	Supply Current	$3\text{V} \leq V_{IN} \leq V_{MAX}$, $V_C = 0.6\text{V}$		4.5	7.0	mA	
	Control Pin Threshold	Duty Cycle = 0	●	0.7 0.5	0.9 1.1 1.25	V V	
	Normal/Flyback Threshold on Feedback Pin			0.58	0.67	0.8	V
f	Switching Frequency		●	50 45	60 70 75	kHz kHz	
		$800\mu\text{A} \geq I_{FB} \geq 450\mu\text{A}$			12	kHz	
BV	Output Switch Breakdown Voltage	$3\text{V} \leq V_{IN} \leq V_{MAX}$, $I_{SW} = 1.5\text{mA}$	●	100	115	V	
	Control Voltage to Switch Current Transconductance			1.5		A/V	
V_{FB}	Flyback Reference Voltage	$I_{FB} = 60\mu\text{A}$	●	17 16	18.6 20.5 21.5	V V	
	Change in Flyback Reference Voltage	$60\mu\text{A} \leq I_{FB} \leq 200\mu\text{A}$		3.5	4.6	6.5	V
	Flyback Reference Voltage Line Regulation	$I_{FB} = 60\mu\text{A}$, $3\text{V} \leq V_{IN} \leq V_{MAX}$			0.01	0.03	%/V
	Flyback Amplifier Transconductance (g_m)	$\Delta I_C = \pm 10\mu\text{A}$		150	300	500	μmho
	Flyback Amplifier Source and Sink Current	$V_C = 0.6\text{V}$ Source $I_{FB} = 60\mu\text{A}$ Sink	● ●	15 30	32 50	70 90	μA μA
V_{SAT}	Output Switch "On" Resistance (Note 2)	$I_{SW} = 0.7\text{A}$ (LT1082C), $I_{SW} = 0.5\text{A}$ (LT1082M)	●	0.8	1.2	Ω	
I_{LIM}	Switch Current Limit (LT1082C)	Duty Cycle = 20%	●	1.07	2.6	A	
		Duty Cycle \leq 50%	●	1.0	2.6	A	
		Duty Cycle = 80% (Note 3)	●	0.8	2.4	A	
	Switch Current Limit (LT1082I)	Duty Cycle = 20%	●	0.85	2.8	A	
		Duty Cycle \leq 50%	●	0.8	2.8	A	
		Duty Cycle = 80% (Note 3)	●	0.65	2.6	A	
	Switch Current Limit (LT1082M)	Duty Cycle = 20%	●	0.75	3.0	A	
		Duty Cycle \leq 50%	●	0.7	3.0	A	
		Duty Cycle = 80% (Note 3)	●	0.6	2.8	A	
ΔI_{IN} ΔI_{SW}	Supply Current Increase During Switch-On Time			35	45	mA/A	
DC_{MAX}	Maximum Switch Duty Cycle			85	92	97	%
	Flyback Sense Delay Time				1.5		μs
	Shutdown Mode Supply Current	$3\text{V} \leq V_{IN} \leq V_{MAX}$, $V_C = 0.05\text{V}$			120	350	μA
	Shutdown Mode Threshold Voltage	$3\text{V} \leq V_{IN} \leq V_{MAX}$	●	70 50	150 250	250 300	mV mV

Note 1: Absolute Maximum Ratings are those values beyond which the life of a device may be impaired.

Note 2: Measured with V_C in hi clamp, $V_{FB} = 0.8\text{V}$.

Note 3: For duty cycles (DC) between 50% and 80%, minimum guaranteed switch current decreases linearly.

TYPICAL PERFORMANCE CHARACTERISTICS

Suggested Core Size and Inductance for Telecom 5V Supply

LOAD CURRENT	TYPE 52 POWDERED IRON	KOOL M μ OR MOLY-PERMALLOY
100mA	T38 250 μ H	T38 200 μ H
200mA	T50 250 μ H	T38 150 μ H
400mA	T60 250 μ H	T50 150 μ H
600mA	T60 250 μ H	T50 200 μ H
800mA	T80 350 μ H	T80 350 μ H

1082 GA

Telecom 5V Supply Efficiency

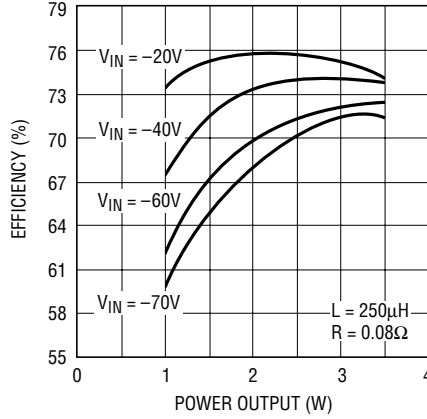

NOTE: THIS GRAPH IS BASED ON LOW CORE LOSS PERMALLOY INDUCTOR. IF POWDERED IRON CORE INDUCTOR IS USED, THE CORE LOSS IS TYPICALLY 100mW HIGHER.

1082 G01

Telecom 5V Supply Short-Circuit Frequency Shift-Down

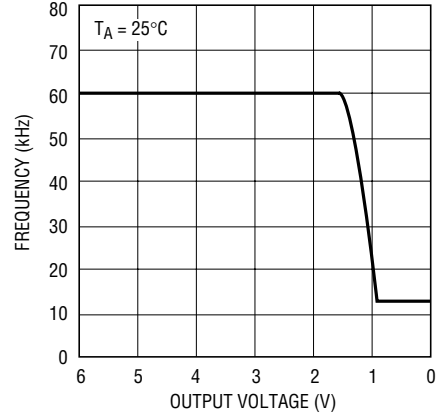

1082 G02

Short-Circuit Frequency Shift-Down vs Feedback Current

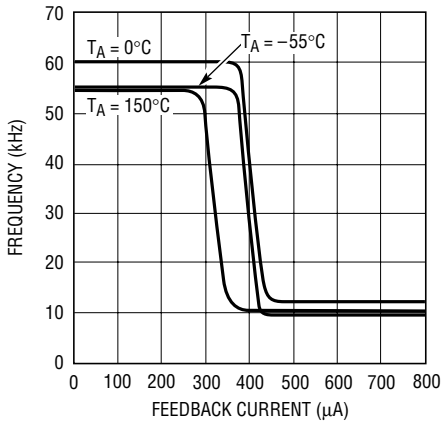

1082 G03

Switch Current Limit

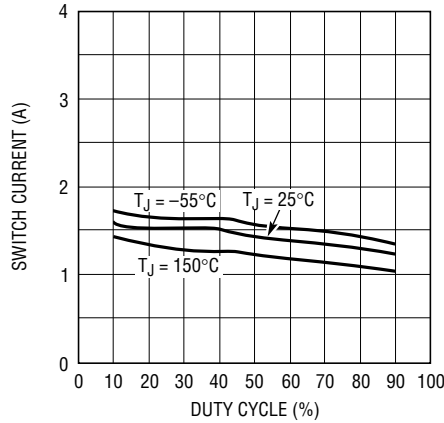

1082 G04

Maximum Duty Cycle

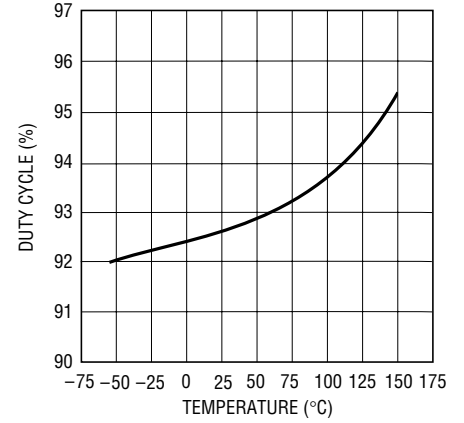

1082 G05

Flyback Blanking Time

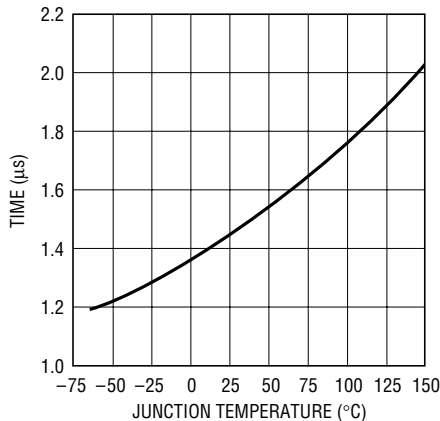

1082 G06

Minimum Input Voltage

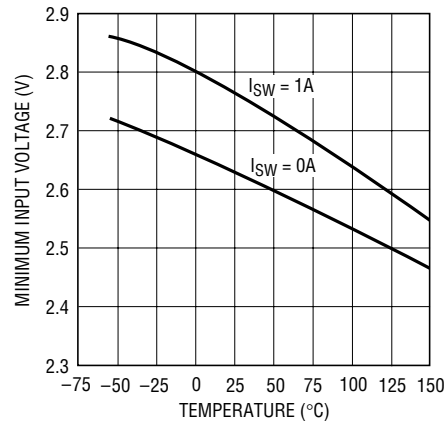

1082 G07

Switch Saturation Voltage

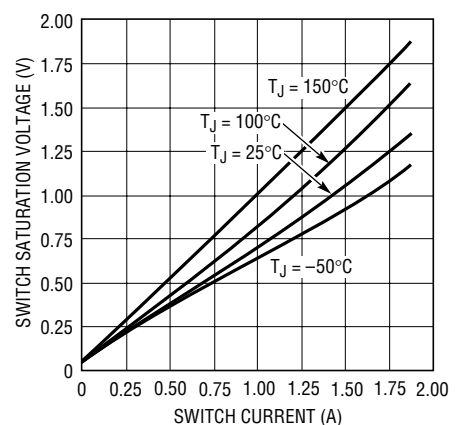

1082 G08

sn1082 1082fas

TYPICAL PERFORMANCE CHARACTERISTICS

Isolated Mode Flyback Reference Voltage

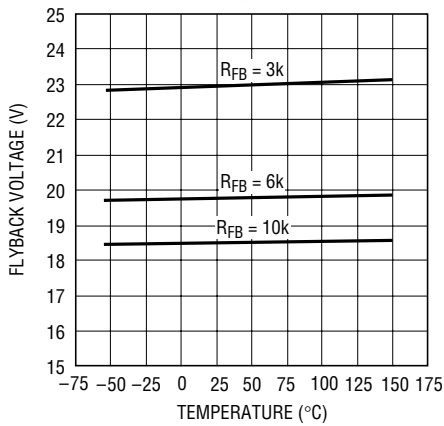

1082 G09

Reference Voltage and Switching Frequency vs Temperature

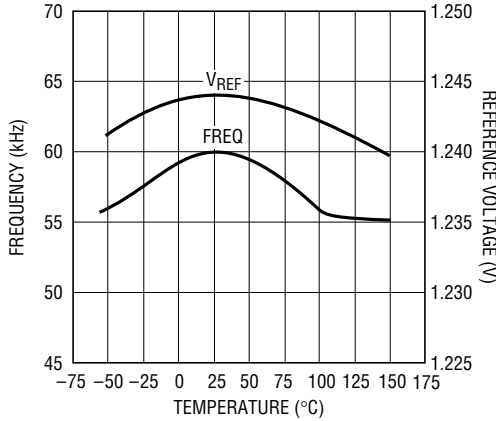

1082 G11

Line Regulation

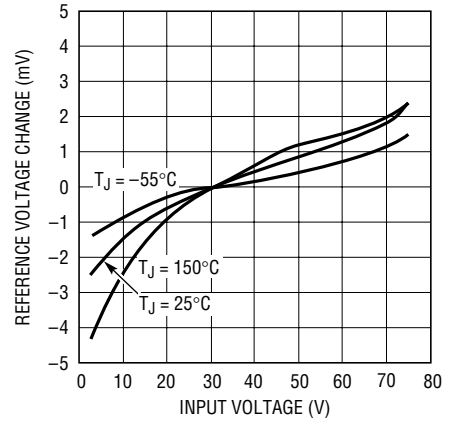

1082 G10

Feedback Bias Current vs Temperature

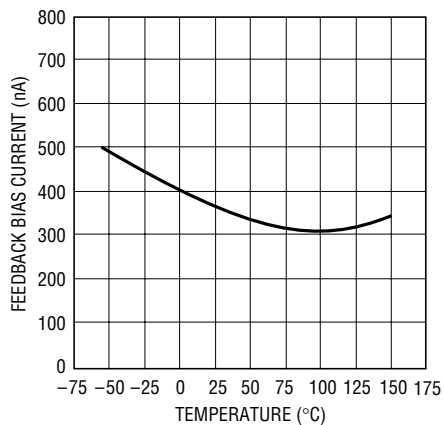

1082 G12

Normal/Feedback Mode Threshold on Feedback Pin

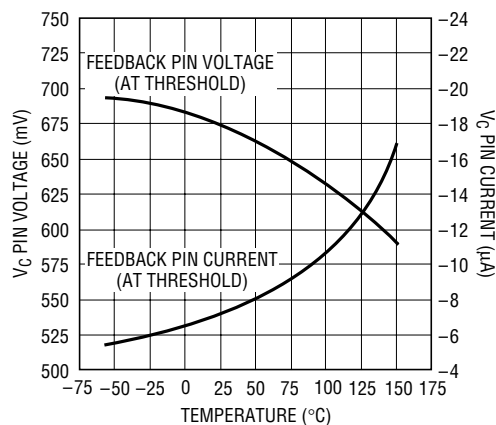

1082 G16

Shutdown Mode Supply Current

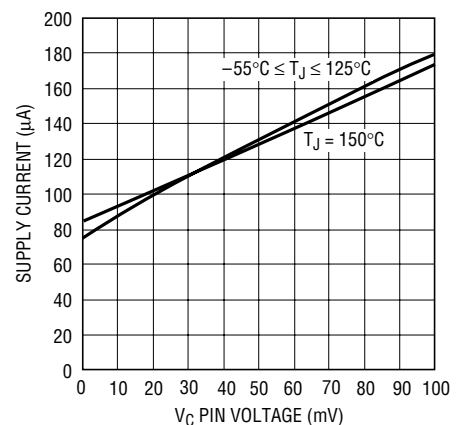

1082 G17

Supply Current vs Supply Voltage (Shutdown Mode)

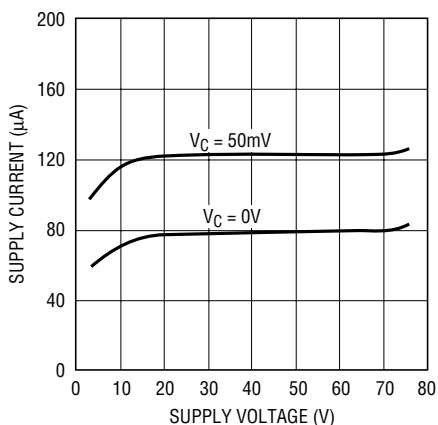

1082 G15

Driver Current* vs Switch Current

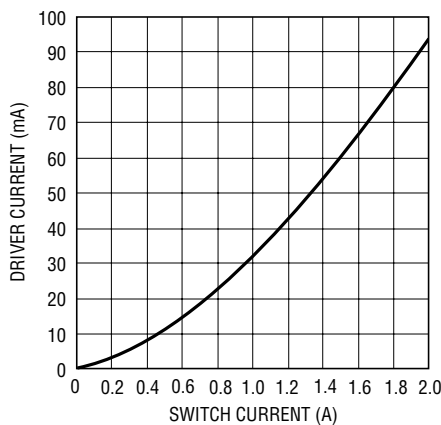

1082 G13

* AVERAGE SUPPLY CURRENT
 $= I_Q + DC(2.9 + 10^{-2} I_{SW} + 10^{-5} I_{SW}^2)$
 I_Q = QUIESCENT CURRENT, DC = DUTY CYCLE,
 I_{SW} = SWITCH CURRENT

Supply Current vs Input Voltage**

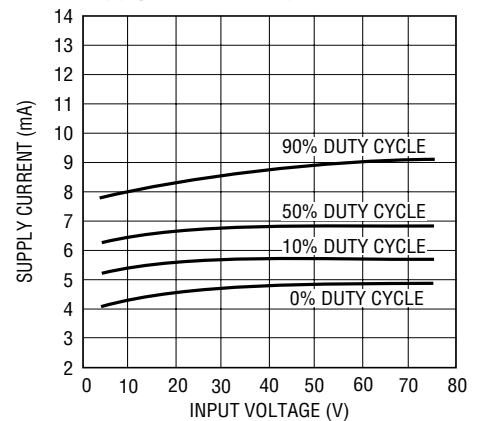

** UNDER VERY LOW OUTPUT CURRENT CONDITIONS, DUTY CYCLE FOR MOST CIRCUITS WILL APPROACH 10% OR LESS.

1082 G14

TYPICAL PERFORMANCE CHARACTERISTICS

Error Amplifier Transconductance

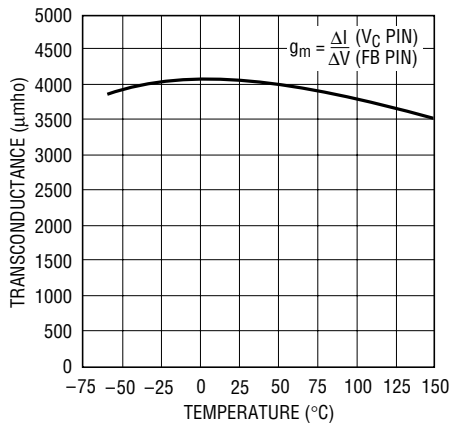

1082 G18

Shutdown Thresholds

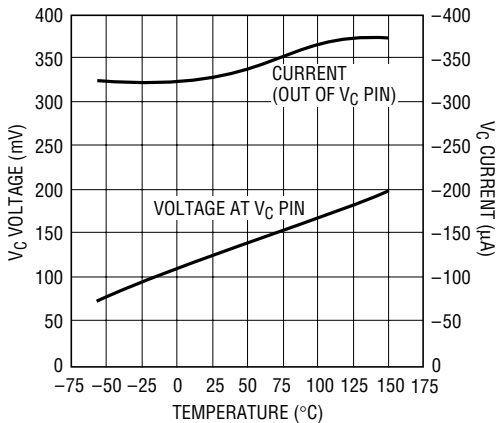

1082 G19

Idle Supply Current vs Temperature

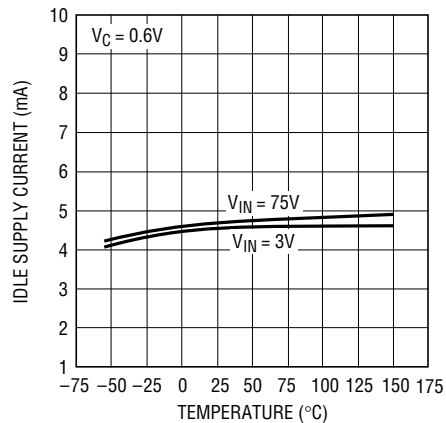

1082 G20

Feedback Pin Clamp Voltage

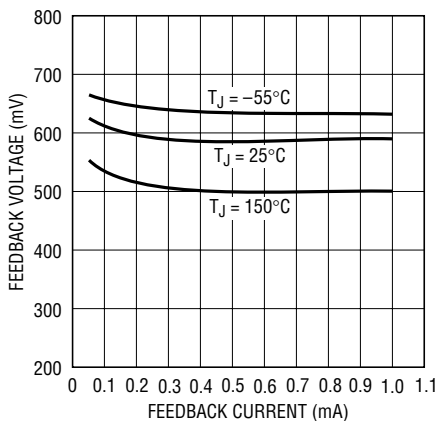

1082 G21

Switch "Off" Characteristics

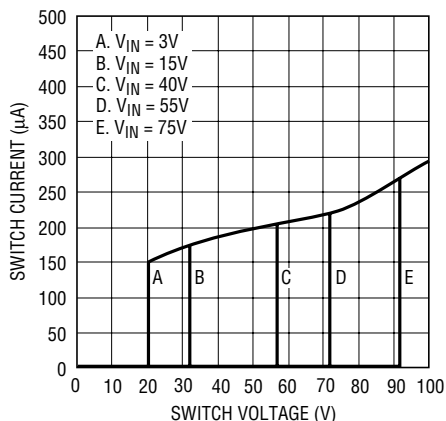

1082 G22

V_C Pin Characteristics

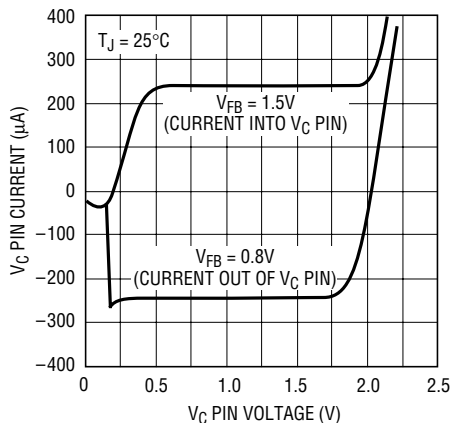

1082 G23

Transconductance of Error Amplifier

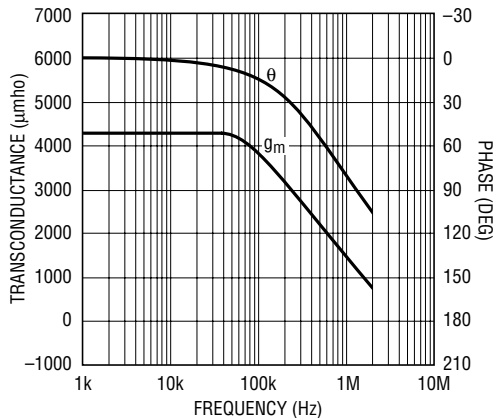

1082 G24

BLOCK DIAGRAM

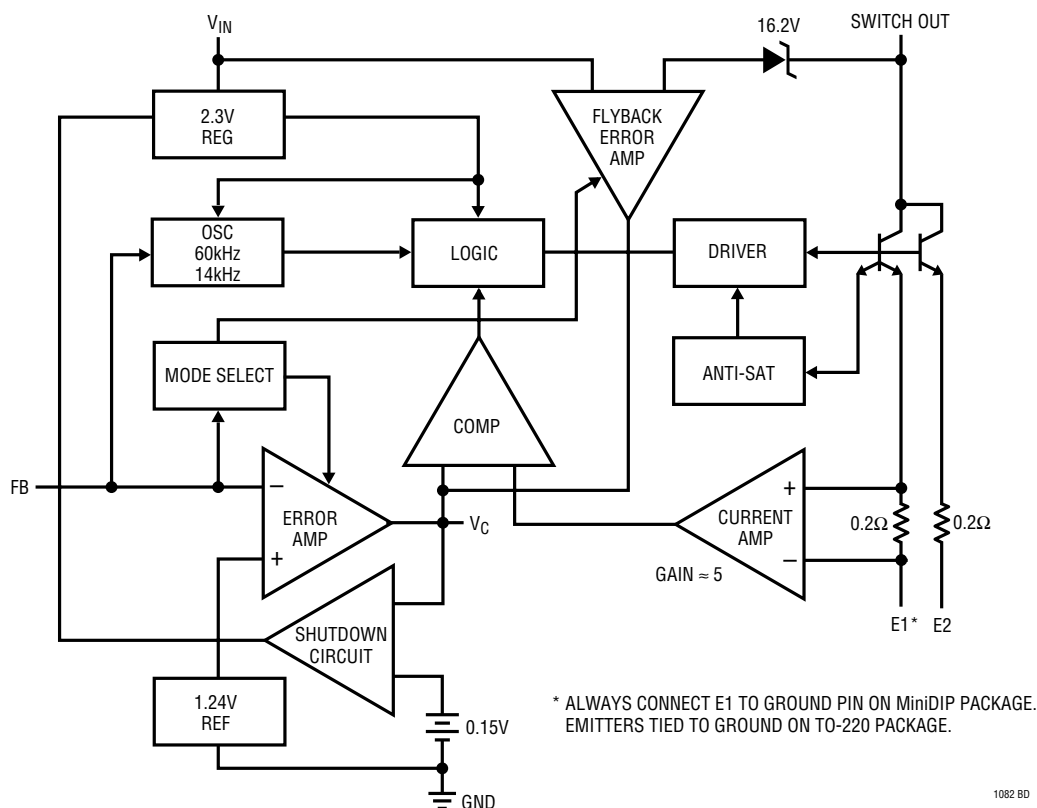

OPERATION

The LT1082 is a current mode switch. This means that switch duty cycle is directly controlled by switch current rather than by output voltage. Referring to the block diagram, the switch is turned “on” at the start of each oscillator cycle. It is turned “off” when switch current reaches a predetermined level. Control of output voltage is obtained by using the output of a voltage sensing error amplifier to set current trip level. This technique has several advantages. First, it has immediate response to input voltage variations, unlike ordinary switchers which have notoriously poor line transient response. Second, it reduces the 90° phase shift at mid-frequencies in the energy storage inductor. This greatly simplifies closed-loop frequency compensation under widely varying input voltage or output load conditions. Finally, it allows simple pulse-by-pulse current limiting to provide maximum switch protection under output overload or short conditions. A

low dropout internal regulator provides a 2.3V supply for all internal circuitry on the LT1082. This low dropout design allows input voltage to vary from 3V to 75V with virtually no change in device performance. A 60kHz oscillator is the basic clock for all internal timing. It turns “on” the output switch via the logic and driver circuitry. Special adaptive anti-sat circuitry detects onset of saturation in the power switch and adjusts driver current instantaneously to limit switch saturation. This minimizes driver dissipation and provides very rapid turn-off of the switch.

A 1.2V bandgap reference biases the positive input of the error amplifier. The negative input is brought out for output voltage sensing. This feedback pin has a second function: when pulled low with an external resistor and with I_{FB} of 60μA to 200μA, it programs the LT1082 to

OPERATION

disconnect the main error amplifier output and connects the output of the flyback amplifier to the comparator input. The LT1082 will then regulate the value of the flyback pulse with respect to the supply voltage. This flyback pulse is directly proportional to output voltage in the traditional transformer coupled flyback topology regulator. By regulating the amplitude of the flyback pulse, the output voltage can be regulated with no direct connection between input and output. The output is fully floating up to the breakdown voltage of the transformer windings. Multiple floating outputs are easily obtained with additional windings. A special delay network inside the LT1082 ignores the leakage inductance spike at the leading edge of the flyback pulse to improve output regulation.

When I_{FB} drawn out of the FB pin reaches $350\mu\text{A}$, the LT1082 shifts the switching frequency down to 12kHz . This unique feature provides high voltage short-circuit protection in systems like the telecom 5V supplies with input voltages down to -70V ; lower frequency is needed under short-circuit conditions with current mode switchers because minimum “on” time cannot be forced below the internally set blanking time. Referring to the telecom 5V supply circuit on the front page, with output shorted to ground, the V_{FB} stays at 0.6V when sourcing I_{FB} up to 1mA . If the FB pin is forced to source more than 1mA , the frequency shifting function may be defeated. Therefore, the minimum suggested value for R_{FB} is 1k and the maximum suggested value is 1.2k . Also, no capacitance more than 1nF should be used on the FB pin, because it may cause unstable switching frequency in this low frequency mode.

The error signal developed at the comparator input is brought out externally. This pin (V_C) has four different functions. It is used for frequency compensation, current limit adjustment, soft starting, and total regulator shutdown. During normal regulator operation this pin sits at a voltage between 0.9V (low output current) and 2V (high output current). The error amplifiers are current output (g_m) types, so this voltage can be externally clamped for adjusting current limit. Likewise, a capacitor-coupled external clamp will provide soft start. Switch duty cycle goes to zero if the V_C pin is pulled to ground through a diode, placing the LT1082 in an idle mode. Pulling the V_C pin below 0.15V causes total regulator shutdown, with

only $120\mu\text{A}$ supply current for shutdown circuitry biasing. See AN19 for full application details.

Extra Pins on the MiniDIP Packages

The miniDIP LT1082 has the emitters of the power transistor brought out separately from the ground pin. This eliminates errors due to ground pin voltage drops and allows the user to reduce switch current limit by a factor of 2:1 by leaving the second emitter (E2) disconnected. The first emitter (E1) should always be connected to the ground pin. Note that switch “on” resistance doubles when E2 is left open, so efficiency will suffer somewhat when switch currents exceed 100mA . Also, note that chip dissipation will actually *increase* with E2 open during normal load operation, even though dissipation in current limit mode will *decrease*. See “Thermal Considerations.”

Thermal Considerations When Using the MiniDIP Packages

The low supply current and high switch efficiency of the LT1082 allow it to be used without a heat sink in most applications when the TO-220 package is selected.

This package is rated at $50^\circ\text{C}/\text{W}$. The miniDIPs, however, are rated at $100^\circ\text{C}/\text{W}$ in ceramic (J) and $90^\circ\text{C}/\text{W}$ in plastic (N).

Care should be taken for miniDIP applications to ensure that the worst case input voltage and load current conditions do not cause excessive die temperatures. The following formulas can be used as a rough guide to calculate LT1082 power dissipation. For more details, the reader is referred to Application Note 19 (AN19), “Efficiency Calculations” section.

Average supply current (including driver current) is:

$$I_{IN} \approx 4.5\text{mA} + I_{SW} (0.004 + \text{DC}/28)$$

I_{SW} = switch current

DC = switch duty cycle

Switch power dissipation is given by:

$$P_{SW} = (I_{SW})^2 \cdot R_{SW} \cdot \text{DC}$$

R_{SW} = LT1082 switch “on” resistance (1.2Ω maximum)

OPERATION

Total power dissipation is the sum of supply current times input voltage plus switch power:

$$P_{TOT} = (I_{IN})(V_{IN}) + P_{SW}$$

In a typical example, using negative-to-positive converter to generate 5V at 0.5A from a -45V input, duty cycle is approximately 12%, and switch current is about 0.5A, yielding:

$$I_{IN} = 4.5\text{mA} + 0.5(0.004 + DC/28) = 8.7\text{mA}$$

$$P_{SW} = (0.5)^2 \cdot 1.2\Omega \cdot (0.12) = 0.036\text{W}$$

$$P_{TOT} = (45\text{V})(8.7\text{mA}) + 0.036 = 0.43\text{W}$$

Temperature rise in a plastic miniDIP would be 90°C/W times 0.43W, or approximately 39°C. The maximum ambient temperature would be limited to 100°C (commercial temperature limit) minus 39°C, or 61°C.

In most applications, full load current is used to calculate die temperature. However, if overload conditions must also be accounted for, four approaches are possible. First, if loss of regulated output is acceptable under overload conditions, the internal *thermal limit* of the LT1082 will protect the die in most applications by shutting off switch current. *Thermal limit* is not a tested parameter, however, and should be considered only for noncritical applications with temporary overloads. A second approach is to use the larger TO-220 (T) package which, even without a heat sink, may limit die temperatures to safe levels under overload conditions. In critical situations, heat sinking of these packages is required; especially if overload conditions must be tolerated for extended periods of time.

The third approach for lower current applications is to leave the second switch emitter (miniDIP only) open. This increases switch “on” resistance by 2:1, but reduces switch current limit by 2:1 also, resulting in a net 2:1 reduction in I²R switch dissipation under current limit conditions.

The fourth approach is to clamp the V_C pin to a voltage less than its internal clamp level of 2V. The LT1082 switch current limit is zero at approximately 1V on the V_C pin and 1.6A at 2V on the V_C pin. Peak switch current can be externally clamped between these two levels with a diode. See AN19 for details.

LT1082 Synchronizing

The LT1082 can be externally synchronized in the frequency range of 75kHz to 90kHz. This is accomplished as shown in the accompanying figures. Synchronizing occurs when the V_C pin is pulled to ground with an external transistor. To avoid disturbing the DC characteristics of the internal error amplifier, the width of the synchronizing pulse should be under 1μs. C2 sets the pulse width at ≈ 0.6μs. The effect of a synchronizing pulse on the LT1082 amplifier offset can be calculated from:

$$\Delta V_{OS} = \frac{\left(\frac{KT}{q}\right)(t_s)(f_s)\left(I_C + \frac{V_C}{R3}\right)}{I_C}$$

KT/q = 26mV at 25°C

t_s = pulse width

f_s = pulse frequency

I_C = LT1082 V_C source current (≈ 200μA)

V_C = LT1082 operating V_C voltage (1V to 2V)

R3 = resistor used to set mid-frequency “zero” in LT1082 frequency compensation network.

With t_s = 0.6μs, f_s = 80kHz, V_C = 1.5V, and R3 = 2k, offset voltage shift is ≈ 5mV. This is not particularly bothersome, but note that high offset could result if R3 were reduced to a much lower value. Also, the synchronizing transistor must sink higher currents with low values of R3, so larger drives may have to be used. The transistor must be capable of pulling the V_C pin to within 100mV of ground to ensure synchronizing.

Synchronizing the LT1082

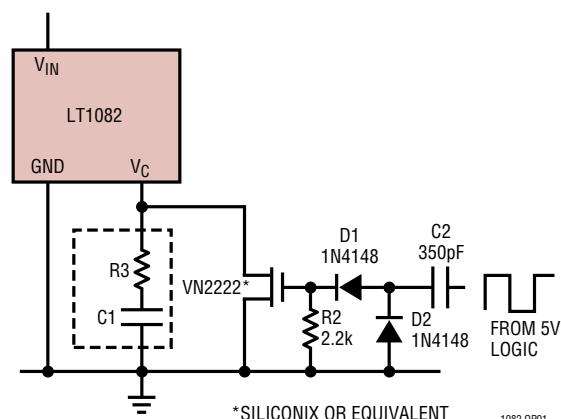

1082 OP01

sn1082 1082fas

TYPICAL APPLICATIONS

Totally Isolated Converter

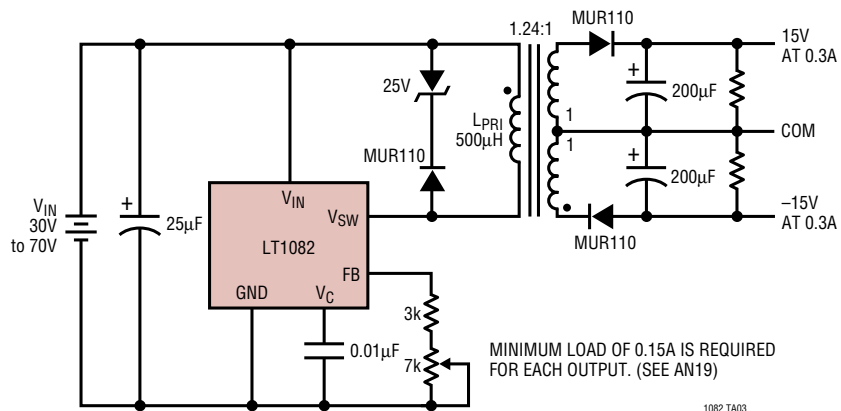

Boost Converter

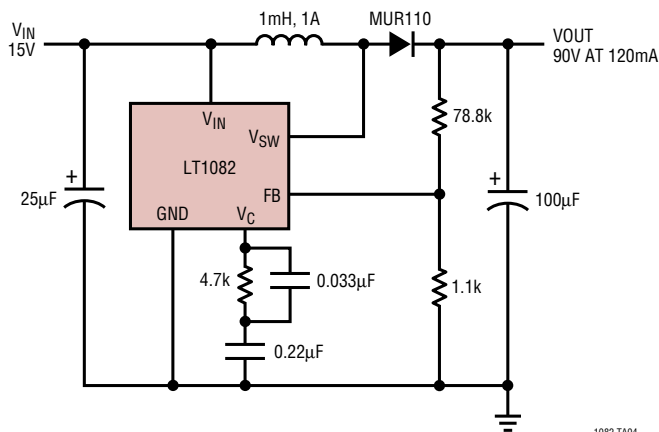

PACKAGE DESCRIPTION

J8 Package
8-Lead Cerdip (Narrow .300 Inch, Hermetic)
 (Reference LTC DWG # 05-08-1110)

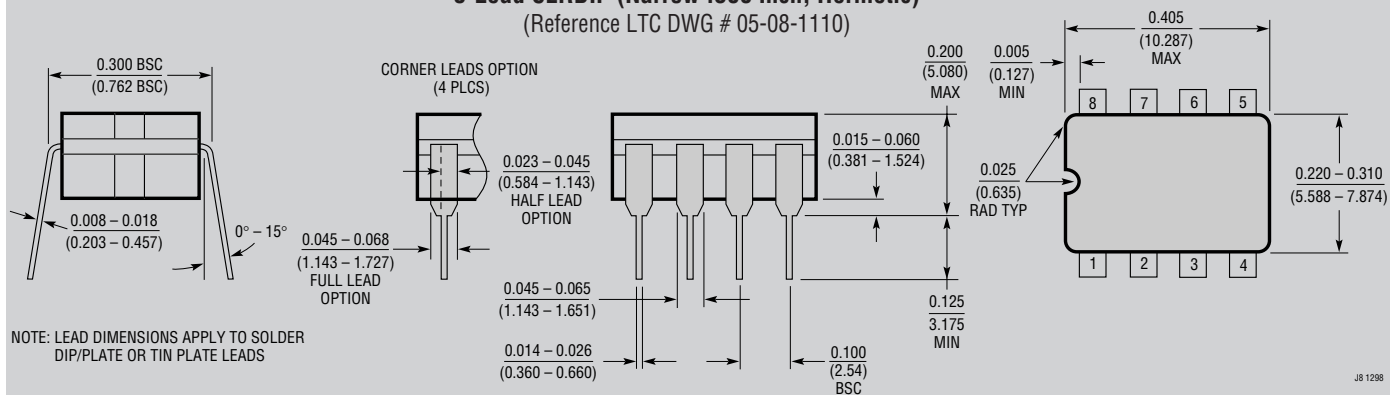

OBsolete PACKAGE

PACKAGE DESCRIPTION

N8 Package 8-Lead PDIP (Narrow .300 Inch) (Reference LTC DWG # 05-08-1510)

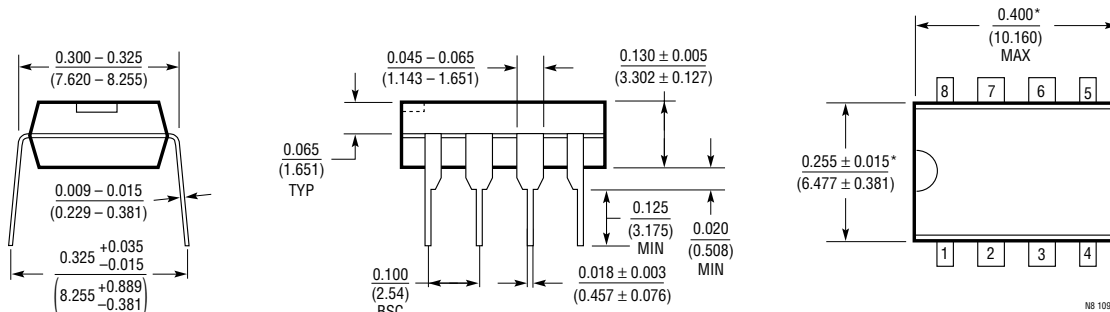

*THESE DIMENSIONS DO NOT INCLUDE MOLD FLASH OR PROTRUSIONS.
MOLD FLASH OR PROTRUSIONS SHALL NOT EXCEED 0.010 INCH (0.254mm)

Q Package 5-Lead Plastic DD Pak (Reference LTC DWG # 05-08-1461)

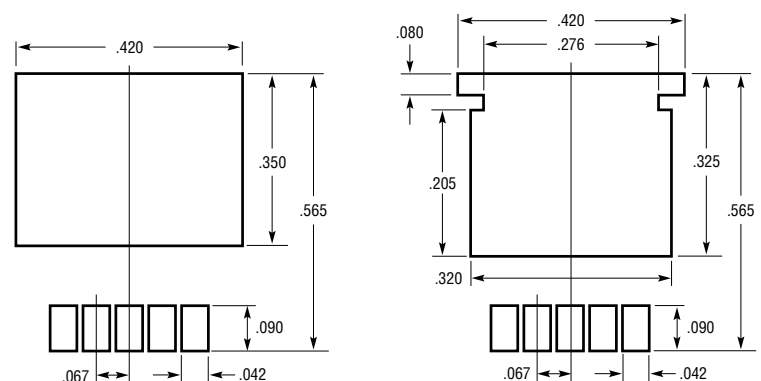
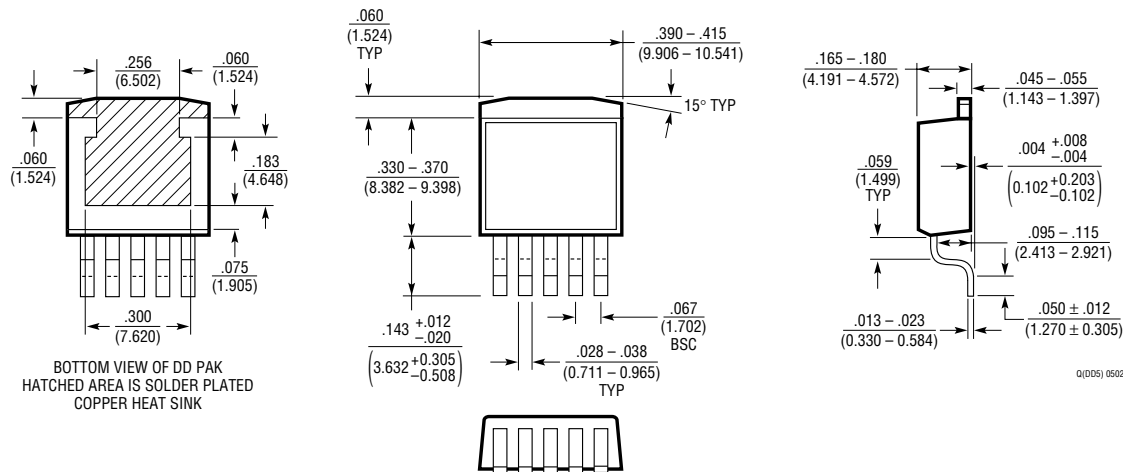

NOTE:
1. DIMENSIONS IN INCH/(MILLIMETER)
2. DRAWING NOT TO SCALE

PACKAGE DESCRIPTION

T Package
5-Lead Plastic TO-220 (Standard)
 (Reference LTC DWG # 05-08-1421)

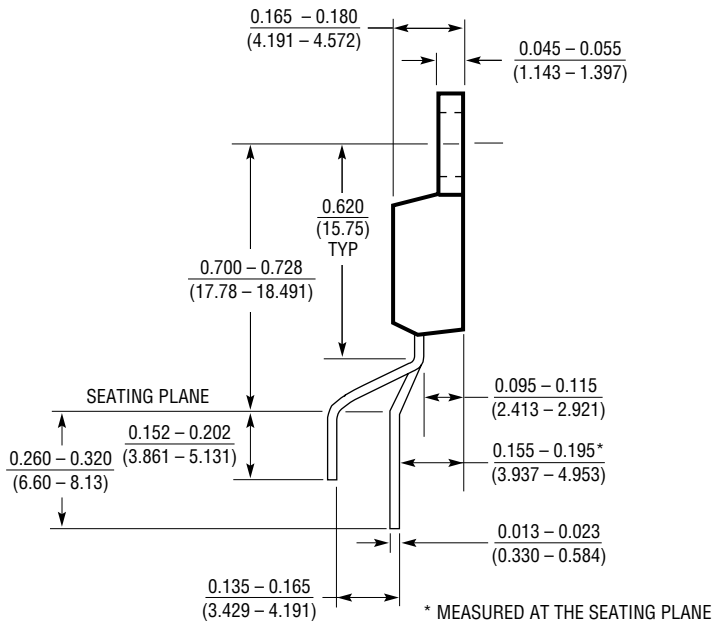
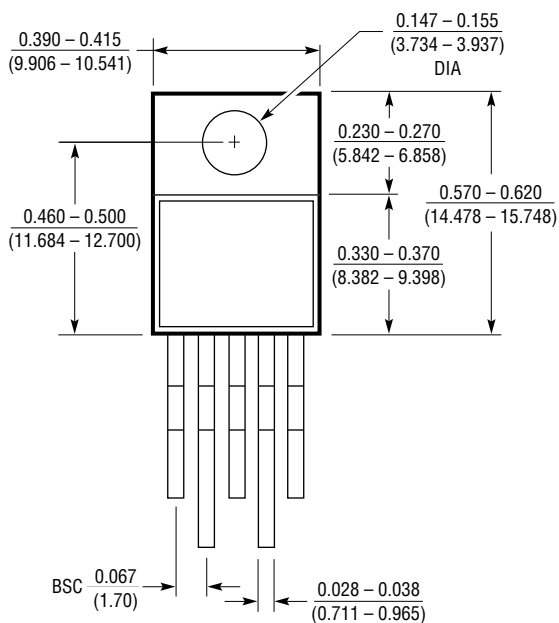

T5 (TO-220) 0399

RELATED PARTS

PART NUMBER	DESCRIPTION	COMMENTS
LT1765	1.25MHz, 3A, Step-Down Regulator	V_{IN} : 3V to 25V, V_{REF} = 1.2V, S08 Package
LT1767	1.25MHz, 1.25A, Step-Down Regulator	V_{IN} : 3V to 25V, V_{REF} = 1.2V, MSOP-8 Package
LTC3401	3MHz, 1A, Step-Up Regulator	V_{IN} : 0.5V to 5V, MSOP-10 Package
LTC3404	1.4MHz, I_{OUT} = 600mA, Step-Down Regulator	V_{IN} : 2.65V to 6V, V_{REF} = 0.8V, MSOP-8 Package
LTC3411	2MHz, 1.25A, Step-Down Regulator	V_{IN} : 2.5V to 5.5V, V_{REF} = 0.8V, MSOP-10, TSSOP-16E Package