

# Micropower High Power DC/DC Converter with Low-Battery Detector

## FEATURES

- 5V at 400mA from 2V Input
- Supply Voltage As Low As 1.8V
- 120µA Quiescent Current
- Low-Battery Detector
- Low  $V_{CESAT}$  Switch: 310mV at 2A Typ
- Uses Inexpensive Surface Mount Inductors
- 8-Lead SO Package

## APPLICATIONS

- 2-Cell and 3-Cell to 5V Conversion
- EL Panel Drivers
- Portable Instruments

## DESCRIPTION

The LT<sup>®</sup>1305 is a micropower step-up DC/DC converter that uses Burst Mode™ operation. Similar to the LT1303, the LT1305 features a 2A internal low-loss switch and can deliver up to four times the output power of the LT1303.

Quiescent current is only 120µA and the Shutdown pin further reduces current to 10µA. A low-battery detector provides an open-collector output that goes low when the input voltage drops below a preset level. The LT1305 is available in an 8-pin SO, easing board space requirements.

LT, LTC and LT are registered trademarks of Linear Technology Corporation. Burst Mode is a trademark of Linear Technology Corporation

## TYPICAL APPLICATION

2-Cell and 3-Cell to 5V/400mA DC/DC Converter with Low-Battery Detect

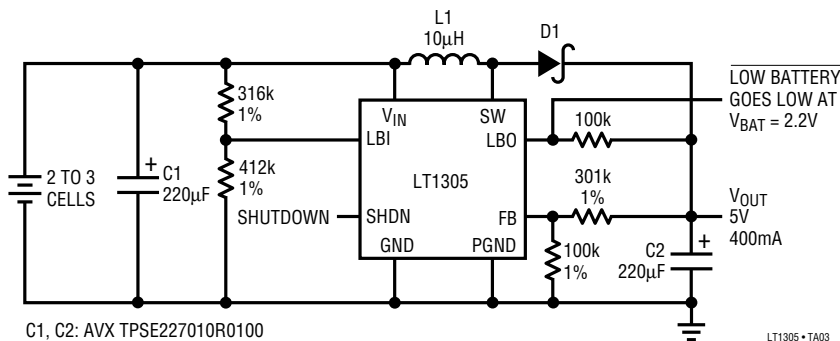

C1, C2: AVX TPSE227010R0100  
 D1: MOTOROLA MBRS130LT3  
 L1: COILCRAFT D03316-103

LT1305 • TA03

Efficiency

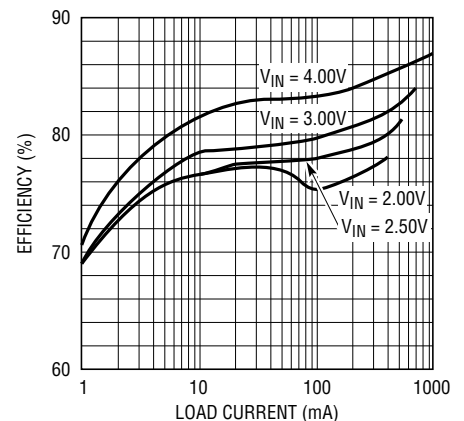

LT1305 • TA02

## ABSOLUTE MAXIMUM RATINGS

$V_{IN}$ Voltage .....	10V
SW1 Voltage .....	25V
FB Voltage .....	10V
Shutdown Voltage .....	10V
LBO Voltage .....	10V
LBI Voltage .....	10V
Maximum Power Dissipation .....	500mW
Operating Temperature Range .....	0°C to 70°C
Storage Temperature Range .....	-65°C to 150°C
Lead Temperature (Soldering, 10 sec).....	300°C

## PACKAGE/ORDER INFORMATION

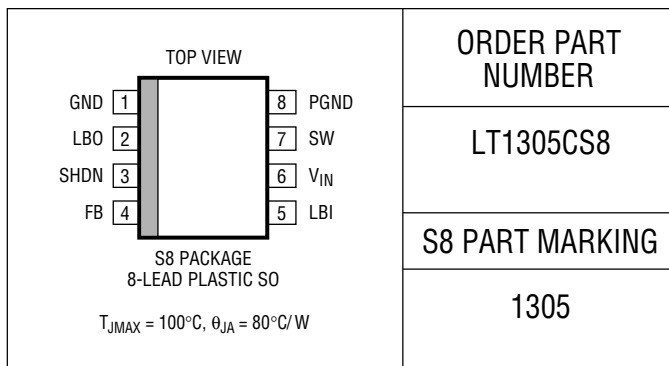

Consult factory for Industrial and Military grade parts.

## ELECTRICAL CHARACTERISTICS $T_A = 25^{\circ}C, V_{IN} = 2.0V$ , unless otherwise noted.

SYMBOL	PARAMETER	CONDITIONS	MIN	TYP	MAX	UNITS	
$I_Q$	Quiescent Current	$V_{SHDN} = 0.5V, V_{FB} = 2V$ $V_{SHDN} = 1.8V$	●	120	200	$\mu A$	
			●	7	15	$\mu A$	
$V_{IN}$	Input Voltage Range		●	1.8	1.55	V	
			●	2.0		V	
	Feedback Voltage		●	1.22	1.24	1.26	V
	Comparator Hysteresis		●	6	12.5	mV	
	Feedback Pin Bias Current	$V_{FB} = 1V$	●	7	20	nA	
	Oscillator Frequency	Current Limit Not Asserted		120	155	185	kHz
	Oscillator TC			0.2		%/°C	
DC	Maximum Duty Cycle		●	75	86	95	%
$t_{ON}$	Switch On Time	Current Limit Not Asserted		5.6		$\mu s$	
	Output Line Regulation	$1.8V < V_{IN} < 6V$	●	0.06	0.15	%/V	
$V_{CESAT}$	Switch Saturation Voltage	$I_{SW} = 1A$	●	140	280	mV	
	Switch Leakage Current	$V_{SW} = 5V$ , Switch Off	●	0.1	10	$\mu A$	
	Peak Switch Current	$V_{IN} = 2V$	●	1.35	2	2.35	A
			●	1.20		2.50	A
				$V_{IN} = 5V$	1.15		2.15
	LBI Trip Voltage	(Note 2)	●	1.21	1.24	1.27	V
	LBI Input Bias Current	$V_{LBI} = 1V$	●	7	20	nA	
	LBO Output Low	$I_{LOAD} = 100\mu A$	●	0.11	0.4	V	
	LBO Leakage Current	$V_{LBI} = 1.3V, V_{LBO} = 5V$	●	0.1	5	$\mu A$	
$V_{SHDNH}$	Shutdown Pin High		●	1.8		V	
$V_{SHDNL}$	Shutdown Pin Low				0.5	V	
$I_{SHDN}$	Shutdown Pin Bias Current	$V_{SHDN} = 5V$ $V_{SHDN} = 2V$ $V_{SHDN} = 0V$	●	8.0	20	$\mu A$	
			●	3.0		$\mu A$	
			●	0.1	1	$\mu A$	

The ● denotes specifications which apply over the 0°C to 70°C operating temperature range.

**Note 1:** Hysteresis specified is DC. Output ripple may be higher if output capacitance is insufficient or capacitor ESR is excessive.

**Note 2:** Low-battery detector comparator is inoperative when device is in shutdown.

# TYPICAL PERFORMANCE CHARACTERISTICS

Switch On Time

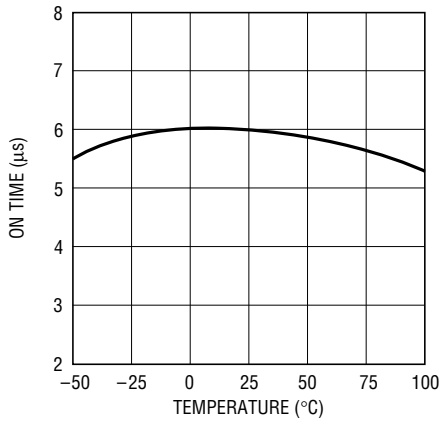

LT1305 • G01

Oscillator Frequency

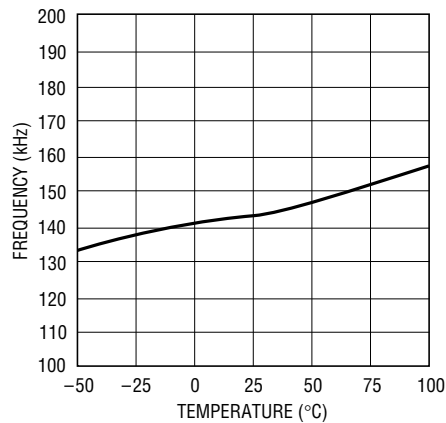

LT1305 • G02

Maximum Duty Cycle

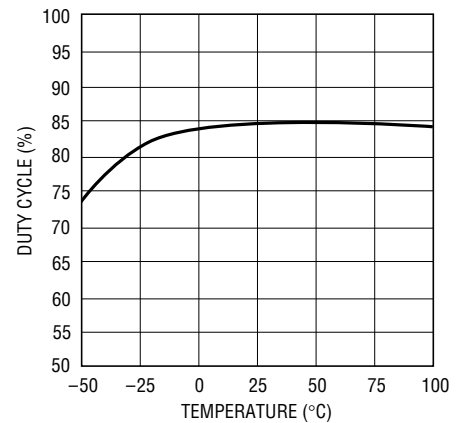

LT1305 • G03

Quiescent Current

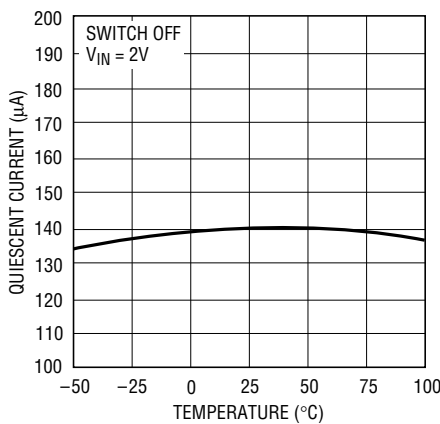

LT1305 • G04

Quiescent Current

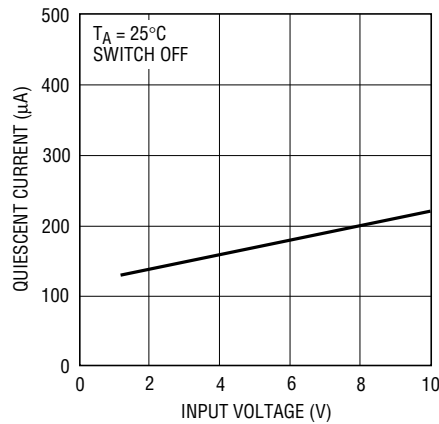

LT1305 • G05

Current Limit

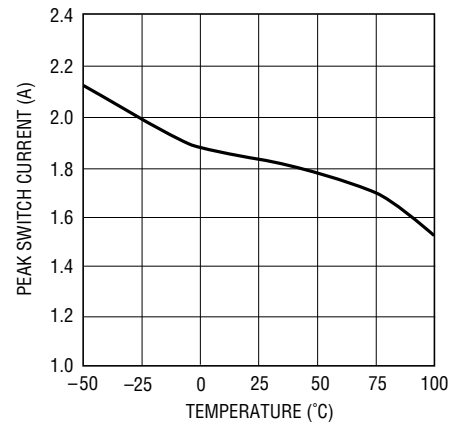

LT1305 • G06

LBI Pin Bias Current

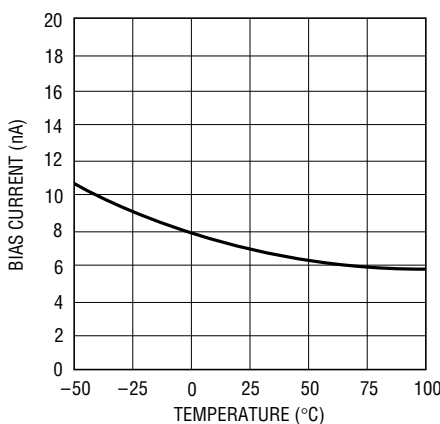

LT1305 • G07

FB Pin Bias Current

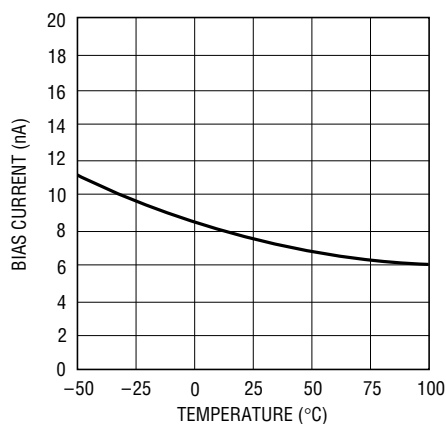

LT1305 • G08

FB Voltage

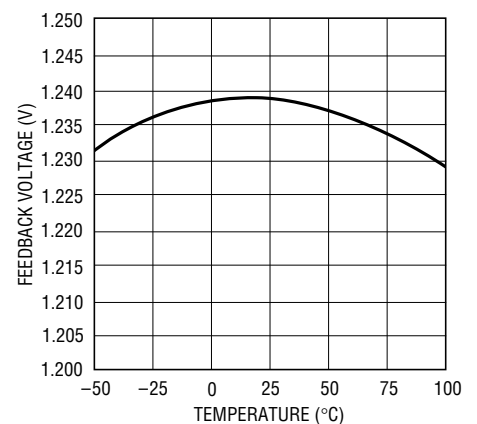

LT1305 • G09

## TYPICAL PERFORMANCE CHARACTERISTICS

Low-Battery Detect Trip Point

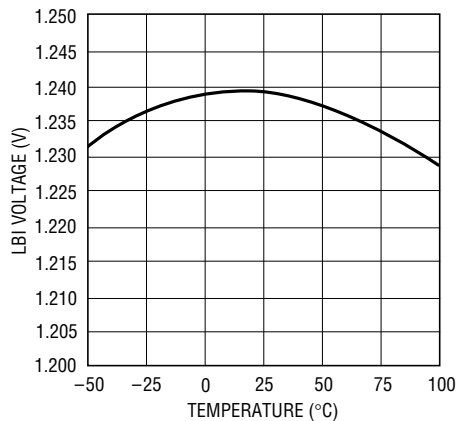

LT1305 • G10

Switch Saturation Voltage

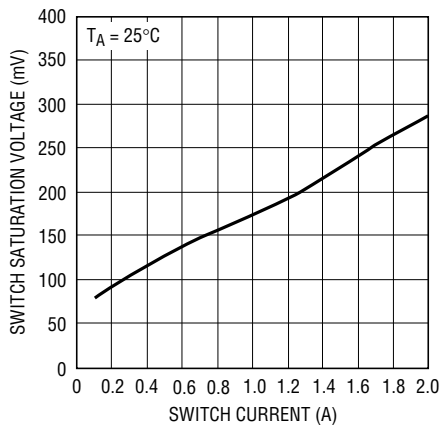

LT1305 • F12

Switch Saturation Voltage

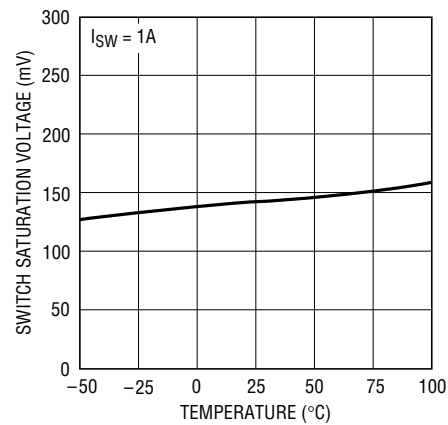

LT1305 • G13

## PIN FUNCTIONS

**GND (Pin 1):** Signal Ground. Tie to PGND under the package.

**LBO (Pin 2):** Open-Collector Output of Comparator C3. Can sink 100 $\mu$ A. High impedance when device is in shut-down.

**SHDN (Pin 3):** Shutdown. Pull high to shut down the LT1305. Ground for normal operation.

**FB (Pin 4):** Feedback Input. Connects to main comparator C1 input.

**LBI (Pin 5):** Low-Battery Comparator Input. When voltage on this pin is below 1.24V, LBO is low.

**V<sub>IN</sub> (Pin 6):** Supply Pin. Must be bypassed with a large value capacitor to ground. Keep bypass within 0.2" of the device.

**SW (Pin 7):** Switch Pin. Connect inductor and diode here. Keep layout short and direct to minimize radio frequency interference.

**PGND (Pin 8):** Power Ground. Tie to signal ground (pin 1) under the package. Bypass capacitor from V<sub>IN</sub> should be tied directly to PGND within 0.2" of the device.

## BLOCK DIAGRAM

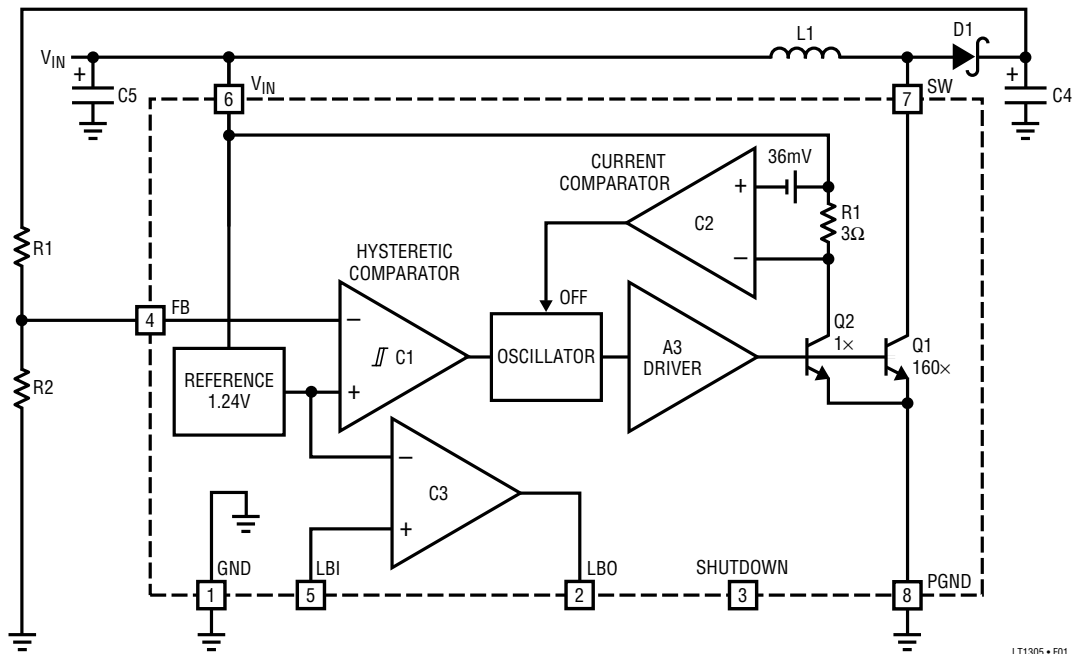

Figure 1. LT1305 Block Diagram

## OPERATION

Operation of the LT1305 is best understood by referring to the Block Diagram in Figure 1. When C1's negative input, related to the output voltage by the appropriate resistor-divider ratio, is higher than the 1.24V reference voltage, C1's output is low. C2, A3 and the oscillator are turned off, drawing no current. Only the reference and C1 consume current, typically 120 $\mu$ A. When C1's negative input drops below 1.24V and overcomes C1's 6mV hysteresis, C1's output goes high, enabling the oscillator, current comparator C2 and driver A3. Quiescent current increases to 2mA as the device goes into active switching mode. Q1 then turns on in controlled saturation for nominally 6 $\mu$ s or until current comparator C2 trips, whichever comes first. The switch then turns off for approximately 1.5 $\mu$ s, then turns on again. The LT1305's switching causes current to alternately build up in L1 and dump into output capacitor C4 via D1, increasing the output voltage. When the output is high enough to cause C1's output to go high, switching action ceases. Capacitor C4 is left to supply current to the load

until  $V_{OUT}$  decreases enough to force C1's output high, and the entire cycle repeats. Figure 2 details relevant waveforms. C1's cycling causes low-to-mid-frequency ripple voltage on the output. Ripple can be reduced by making the output capacitor large. The 220 $\mu$ F unit specified results in ripple of 50mV to 100mV on the 5V output. Paralleling two capacitors will decrease ripple by approximately 50%.

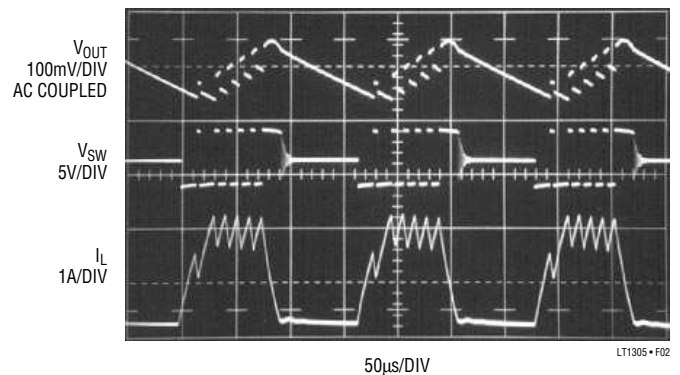

Figure 2. Burst Mode Operation

## OPERATION

If switch current reaches 2A, causing C2 to trip, switch on time is reduced and off time increases slightly. This allows continuous operation during bursts. C2 monitors the voltage across 3Ω resistor R1 which is directly related to the switch current. Q2's collector current is set by the emitter-area ratio to 0.6% of Q1's collector current. When R1's voltage drop exceeds 36mV, corresponding to 2A switch current, C2's output goes high, truncating the on time portion of the oscillator cycle and increasing off time to about 2μs. Response time of C2, which determines minimum on time, is approximately 300ns.

### Low-Battery Detector

The low-battery detector is enabled when SHDN is low and disabled when SHDN is high. The comparator has no hysteresis built in, but hysteresis can be added by connecting a high-value resistor from LBI to LBO as shown in Figure 3. The internal reference can be accessed via the comparator as shown in Figure 4.

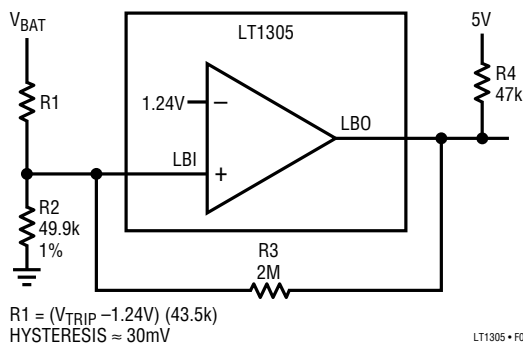

Figure 3. R3 Adds Hysteresis to Low-Battery Detector

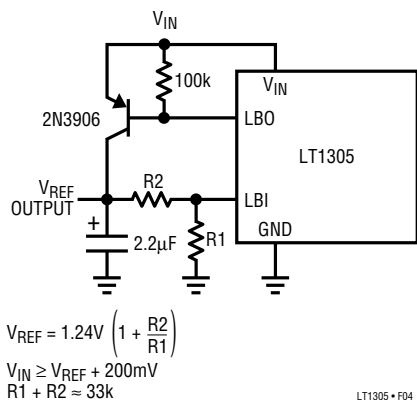

Figure 4. Accessing Internal Reference

### Inductor Selection

Inductors used with the LT1305 must fulfill two requirements. First, the inductor must be able to handle current of 2A to 2.5A without runaway saturation. Rod or drum core units usually saturate gradually and it is acceptable to exceed manufacturer's published saturation current by 20% or so. Second, the unit must have low DCR, under 0.05Ω so that copper loss is kept low and excess heating is avoided. Inductance value is not critical. Generally, for low voltage inputs below 3V a 10μH inductor is recommended (such as Coilcraft DO3316-103). For inputs above 4V to 5V use a 22μH unit (such as Coilcraft DO3316-223). Switching frequency can reach up to 300kHz so the core material should be able to operate at high frequency without excessive core loss. Ferrite or molypermalloy cores are a better choice than powdered iron. If EMI is a concern, a toroidal inductor is suggested, such as Coiltronics CTX20-4.

### Capacitor Selection

Output and input capacitors should have low ESR for best performance. Inexpensive aluminum electrolytics sometimes have ESR above 1Ω, even for relatively large values such as 100μF, 16V units. Since the LT1305 has a 2A current limit, 2V of ripple voltage would result with such a capacitor at the output. Keep ESR below 0.05Ω to 0.1Ω for reasonable ripple voltage. Tantalum capacitors such as AVX TPS series or Sprague 593D have low ESR and are surface mount components. For lowest ESR, use Sanyo OS-CON units (OS-CON is also available from Vishay). These capacitors have superior ESR, small size and perform well at cold temperatures.

### Diode Selection

A 2A Schottky diode such as Motorola MBRS130LT3 is a good choice for the rectifier diode. A 1N5821 or MBRS130T3 are suitable as well. Do not use "general purpose" diodes such as 1N4001. They are much too slow for use in switching regulator applications.

# TYPICAL APPLICATIONS

Setting Output Voltage

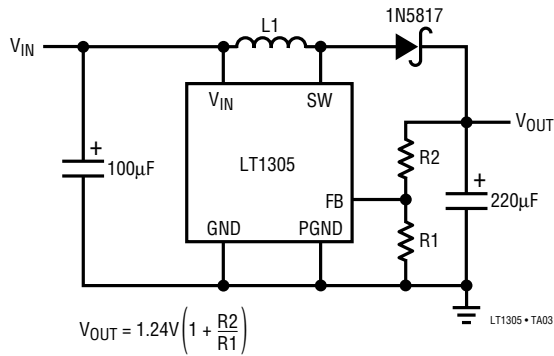

4-Cell-to-5V Converter

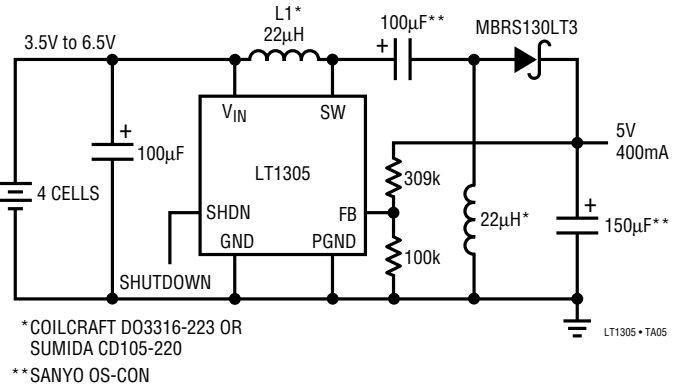

5V Step-Up Converter with Reference Output

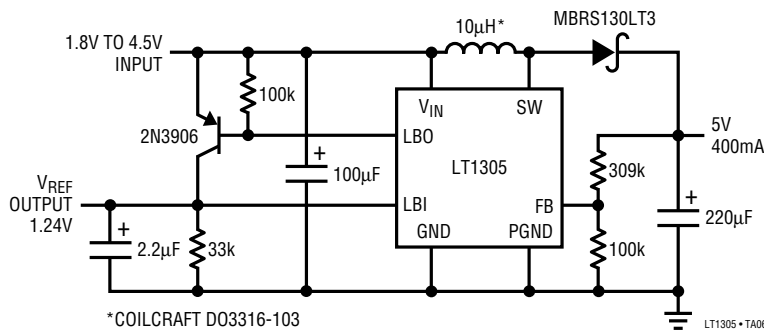

EL Panel Driver

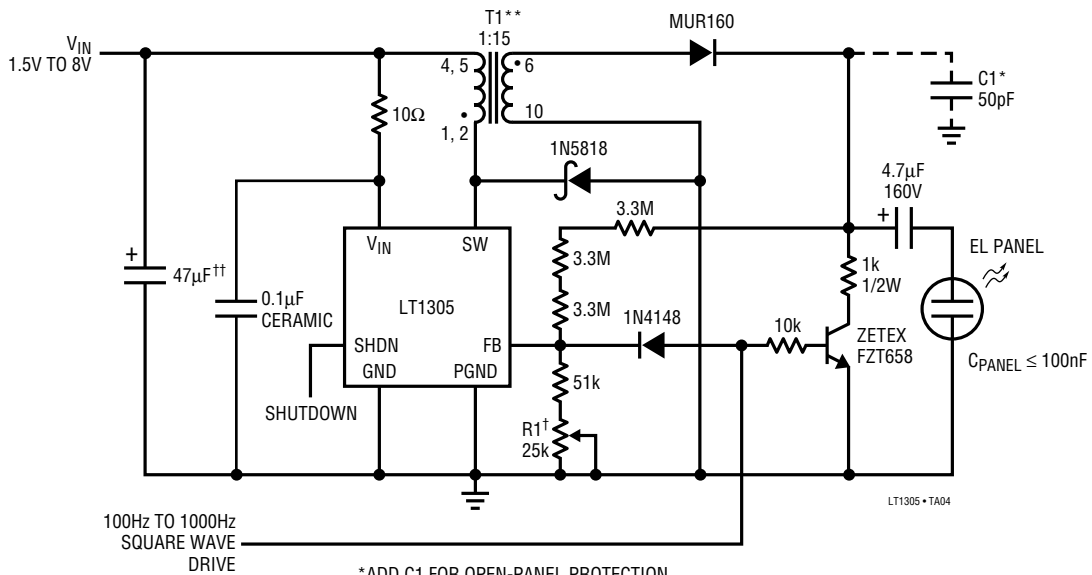

**PACKAGE DESCRIPTION**

Dimensions in inches (millimeters) unless otherwise noted.

**S8 Package  
8-Lead Plastic SOIC**

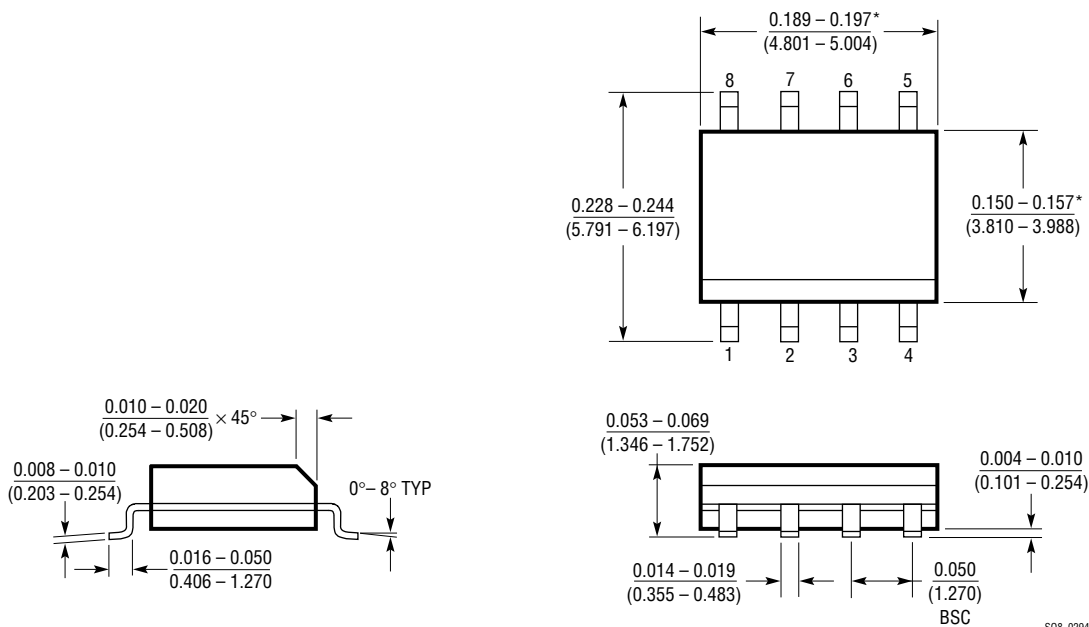

\*THESE DIMENSIONS DO NOT INCLUDE MOLD FLASH OR PROTRUSIONS.  
MOLD FLASH OR PROTRUSIONS SHALL NOT EXCEED 0.006 INCH (0.15mm).

**RELATED PARTS**

PART NUMBER	DESCRIPTION	COMMENTS
LT1129	Micropower Low Dropout Regulator	700mA Output Current in SO-8 Package
LT1182/83/84	LCD and CCFL Backlight Controller	High Efficiency and Excellent Backlight Control Range
LT1301	5V to 12V/200mA Step-Up DC/DC Converter	120µA Quiescent Current
LT1302	2-Cell to 5V/600mA Step-Up DC/DC Converter	200µA Quiescent Current
LT1303	Micropower DC/DC Converter with Low-Battery Detect	2V to 5V at 200mA
LT1372	500kHz Step-Up PWM, 1.5A Switch	Low Noise, Fixed Frequency Operation
LTC <sup>®</sup> 1472	PCMCIA Host Switch with Protection	Includes Current Limit and Thermal Shutdown