

500kHz Micropower DC/DC Converter for Flash Memory

OBSOLETE:

FOR INFORMATION PURPOSES ONLY
 Contact Linear Technology for Potential Replacement

FEATURES

- 60mA Output Current at 12V from 3V or 5V Supply
- Shutdown to 9 μ A
- $\overline{VPP\ VALID}$ Comparator
- Up to 85% Efficiency
- Switching Frequency: 500kHz (Typical)
- Quiescent Current: 650 μ A
- Low V_{CESAT} Switch: 300mV at 0.5A (Typical)
- Soft Start Reduces Supply Current Transients
- Uses Low Value, Small Size, Surface Mount Inductors
- Available in 8-Lead SO Package

APPLICATIONS

- Flash Memory VPP Generators
- Type II and III PCMCIA Card DC/DC Converters
- 3V to 12V, 5V to 12V Converters
- Portable Computers and Instruments
- Cellular Telephones
- DC/DC Converter Module Replacements

DESCRIPTION

The LT[®]1309 is a 500kHz micropower DC/DC converter for Flash Memory. The regulator features Burst Mode[™] operation with a 0.5A, 300mV switch, enabling 85% efficiency at the fixed 12V output. High frequency operation permits the use of small value, and therefore small size, surface mount inductors and capacitors. The LT1309 comes in an 8-lead SO package allowing extremely compact PC board layouts. These features make the device attractive for PCMCIA cards, cellular phones and other applications where PC board space is limited.

Quiescent current is 650 μ A decreasing to 9 μ A when the part shuts down. The device includes a soft start feature which limits supply current transients during turn-on.

The LT1309 contains a $\overline{VPP\ VALID}$ comparator with a logic output that goes low when the output voltage is ready to program 12V Flash Memory. This comparator simplifies the interface to external control logic.

LT, LTC and LT are registered trademarks of Linear Technology Corporation. Burst Mode is a trademark of Linear Technology Corporation.

TYPICAL APPLICATION

12V, 60mA Flash Memory Programming Supply

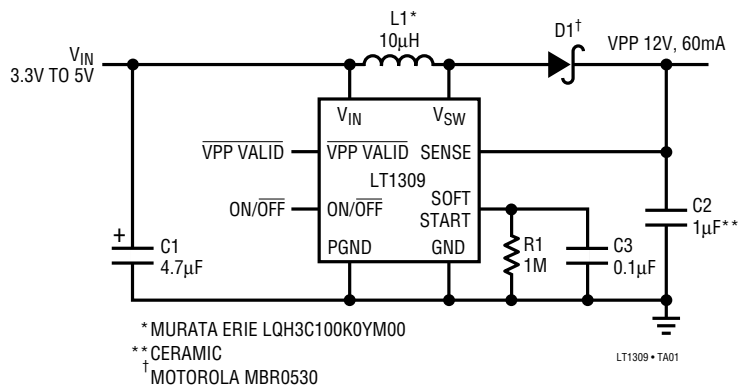

12V Output Efficiency

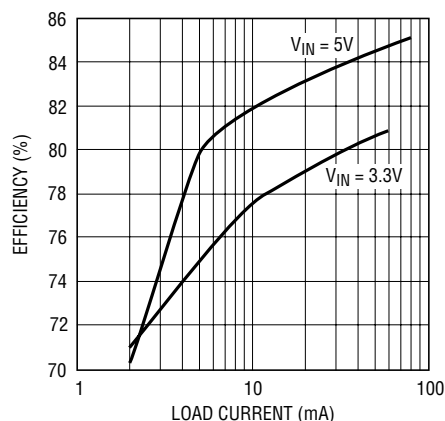

ABSOLUTE MAXIMUM RATINGS

V_{CC} Voltage	7V
V_{SW} Voltage	20V
V_{SENSE} Voltage	20V
$V_{ON/OFF}$ Voltage	7V
V_{SEL} Voltage	7V
I_{LIM} Voltage	7V
Maximum Power Dissipation	500mW
Operating Temperature Range	0°C to 70°C
Storage Temperature Range	-65°C to 150°C
Lead Temperature (Soldering, 10 sec)	300°C

PACKAGE/ORDER INFORMATION

	ORDER PART NUMBER
	LT1309CS8
	S8 PART MARKING
	1309

Consult factory for Industrial and Military grade parts.

ELECTRICAL CHARACTERISTICS $T_A = 25^\circ\text{C}$, $V_{CC} = 5\text{V}$, $V_{ON/OFF} = 3\text{V}$, unless otherwise noted.

SYMBOL	PARAMETER	CONDITIONS	MIN	TYP	MAX	UNITS
I_Q	Quiescent Current	$V_{SENSE} = 12\text{V}$		650	900	μA
	Quiescent Current, Shutdown	$V_{ON/OFF} = 0.2\text{V}$		9	15	μA
	Input Voltage Range		2		6	V
	Output Sense Voltage	●	11.5	12	12.6	V
	Output Referred Comparator Hysteresis			35		mV
f_{OSC}	Oscillator Frequency	Current Limit Not Asserted	400	500	700	kHz
DC	Maximum Duty Cycle	●	80	85	92	%
t_{ON}	Switch ON Time			1.7		μs
	Reference Line Regulation	$2\text{V} < V_{IN} < 6\text{V}$		0.06	0.15	%/V
V_{CESAT}	Switch Saturation Voltage	$I_{SW} = 0.5\text{A}$		230	350	mV
	Switch Leakage Current	$V_{SW} = 12\text{V}$, Switch Off		0.1	10	μA
	Switch Current Limit	$V_{IN} = 5\text{V}$, Soft Start Floating $V_{IN} = 3\text{V}$, Soft Start Floating	400 450	600 650	900 950	mA
	Soft Start Current	Soft Start Grounded		80	120	μA
	ON/OFF Input Voltage Low				0.8	V
	ON/OFF Input Voltage High		1.6			V
	ON/OFF Bias Current	$V_{ON/OFF} = 5\text{V}$ $V_{ON/OFF} = 3\text{V}$ $V_{ON/OFF} = 0\text{V}$		16.0 8.0 0.1	24.0 14.0 1.0	μA
	Sense Pin Input Current	$V_{ON/OFF} = 0.2\text{V}$		50.0 0.1	90 1	μA
	VPP VALID Threshold	V_{SENSE} Rising (High to Low Transition)		$V_{SENSE} - 200\text{mV}$		
	VPP VALID Output Voltage Low	$I_{SINK} = 100\mu\text{A}$		0.13	0.3	V
	VPP VALID Output Voltage High	$I_{SOURCE} = 2.5\mu\text{A}$	4	4.5		V

The ● denotes specifications which apply over the full operating temperature range.

TYPICAL PERFORMANCE CHARACTERISTICS

Oscillator Frequency

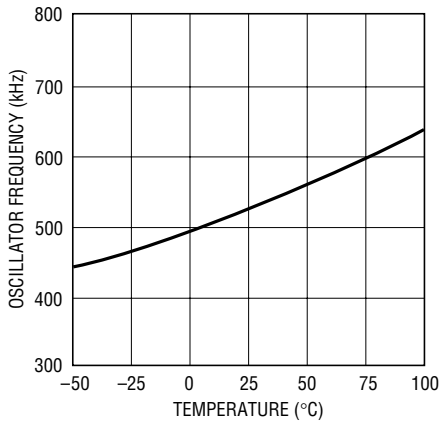

1309 G01

Switch Current Limit

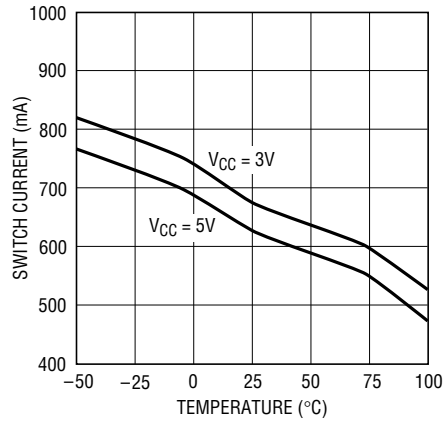

1309 G02

Switch Saturation Voltage

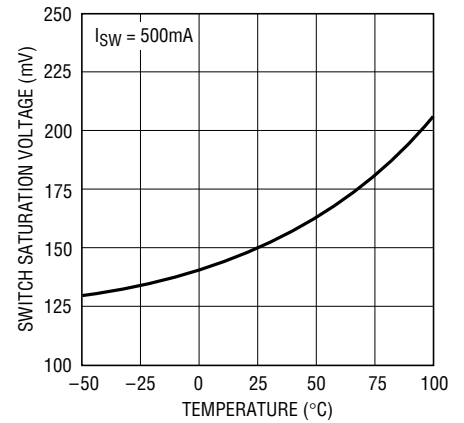

1309 G03

Sense Voltage

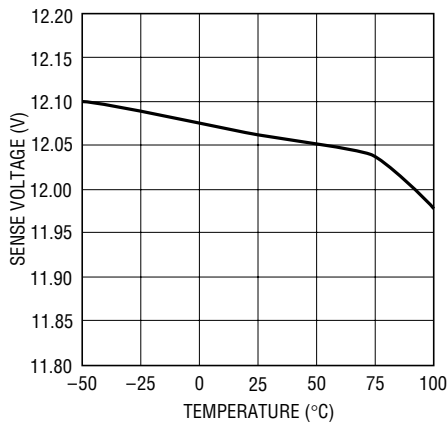

1309 G04

Supply Current

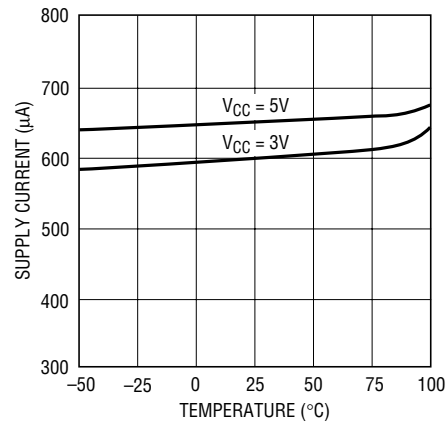

1309 G05

Supply Current in Shutdown

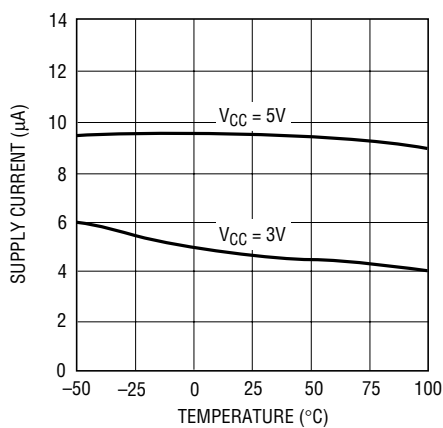

1309 G06

Maximum Duty Cycle

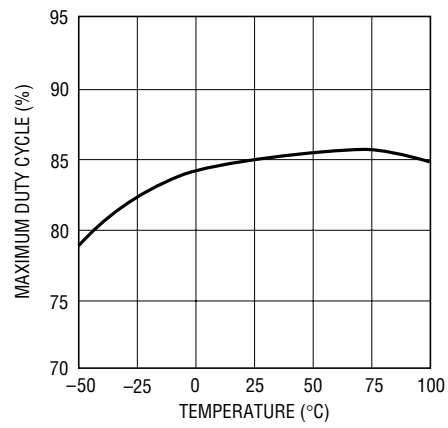

1309 G07

TYPICAL PERFORMANCE CHARACTERISTICS

Start-Up Waveforms, $I_{LOAD} = 1\text{mA}$

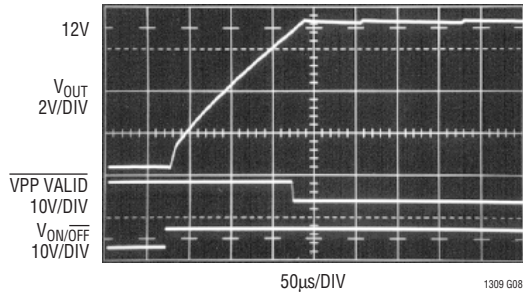

Start-Up Waveforms, $I_{LOAD} = 10\text{mA}$

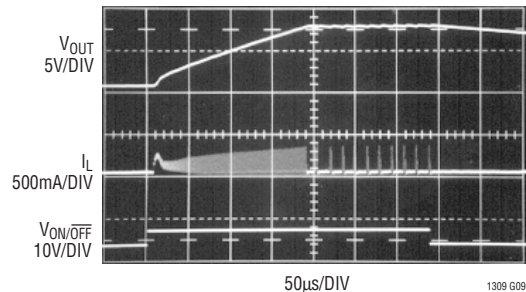

Load Transient Response,
 $C_{OUT} = 1\mu\text{F}$

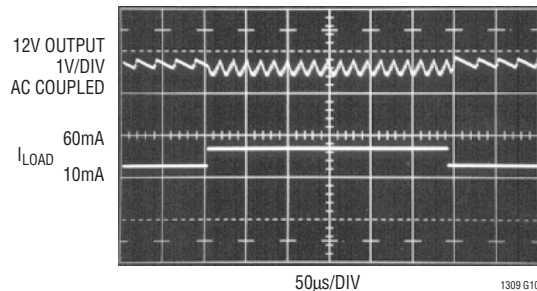

PIN FUNCTIONS

SOFT START (Pin 1): A $0.1\mu\text{F}/1\text{M}\Omega$ parallel RC from this pin to GND provides a Soft Start function upon device turn-on. Initially about $80\mu\text{A}$ will flow from the pin into the capacitor. When the voltage at the pin reaches approximately 0.4V, current ceases flowing out of the pin.

V_{CC} (Pin 2): Input Supply. At least $1\mu\text{F}$ input bypass capacitance is required. More capacitance reduces ringing on the supply line.

PGND (Pin 3): Power Ground. Connect to ground plane.

V_{SW} (Pin 4): Collector of Power Switch. High dV/dt present on this pin. To minimize radiated noise keep layout short and direct.

GND (Pin 5): Signal Ground. Connect to ground plane.

$\overline{VPP\ VALID}$ (Pin 6): This pin provides a logic signal indicating that output voltage has reached 12V. Active low with internal 200k pull-up resistor.

SENSE (Pin 7): Output Sense Pin. This pin connects to a resistive divider that sets the output voltage. In shutdown, the resistor string is disconnected and current into this pin reduces to $< 1\mu\text{A}$.

$\overline{ON/OFF}$ (Pin 8): Shutdown Control. When pulled below 1.5V, this pin disables the LT1309 and reduces supply current to $9\mu\text{A}$. All circuitry is disabled in shutdown. The part is enabled when $\overline{ON/OFF}$ is greater than 1.5V.

BLOCK DIAGRAM

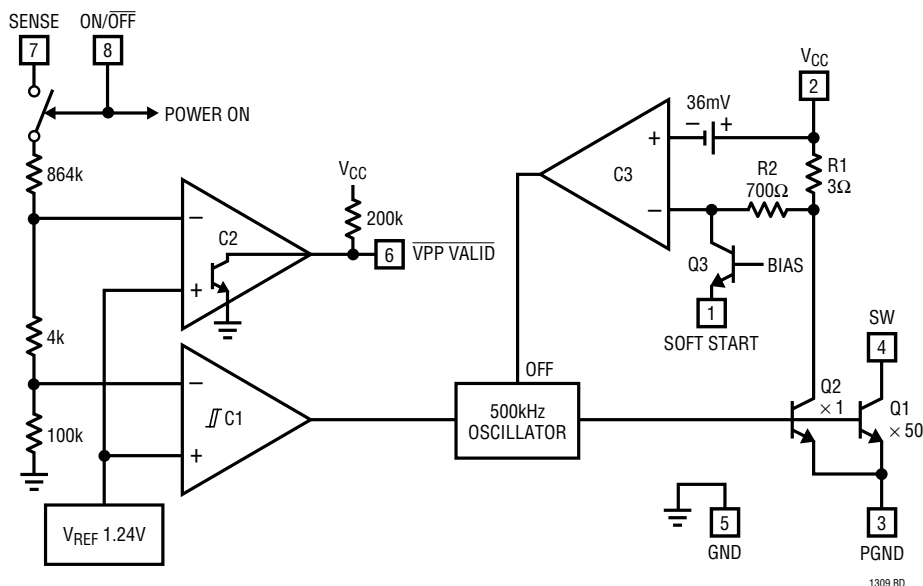

OPERATION

The LT1309 is a current limited, Burst Mode (gated oscillator) type switching regulator that produces a 12V output from a 3.3V or 5V input. Operation can best be understood by referring to the Block Diagram. When the voltage at the Sense pin (Pin 7) is less than 12V, comparator C1 enables the oscillator, turning switches Q1 and Q2 on. The switch turns off when current limit is reached or when the oscillator maximum on-time is reached. When

Q2 turns off, current built up in the inductor flows into the output capacitor and load. This action occurs until the output voltage reaches 12V. During start-up, the Sense pin voltage is either 3.3V or 5V, depending on the input. The $\overline{VPP\ VALID}$ signal remains high until the output voltage reaches 12V, signaling correct voltage level to program flash memory. Connecting a $1\mu\text{F}/0.1\mu\text{F}$ parallel RC to the Soft Start pin limits inrush current during start-up.

APPLICATIONS INFORMATION

Inductor Selection

The low inductance value required with the LT1309 (10 μ H) allows the use of very small units such as the Murata-Erie LQH3C100. Requirements for the inductor include low DCR, ability to perform efficiently at 500kHz and a saturation current rating of 700mA to 900mA. Often inductor manufacturers rate maximum current for a small inductor based on self-heating considerations. For use in switching regulators where the inductor current is not constant the maximum specified DC current can be safely exceeded.

Capacitor Selection

The LT1309 needs very little input and output capacitance to function. Output capacitance should be 1 μ F or 2 μ F for acceptable output ripple voltage. Flash memory tolerates higher ripple voltage than might be suitable for a low noise system. The capacitor can be either a single high capacitance ceramic unit such as Tokin 1E105ZY5U-203 or Murata-Erie GRM230Y5V105Z016, or can be distributed as 10 to 20 0.1 μ F ceramic units. Lower ripple can be

obtained by increasing the capacitance to the 5 μ F to 10 μ F level. 2 μ F to 5 μ F of tantalum (low-Q) capacitance is recommended on the input side to reduce resonance effects which can otherwise cause hundreds of millivolts of ripple voltage at the input.

Diode Selection

The LT1309's high switching speed demands a high speed rectifier. Schottky diodes are preferred for their low forward drop and fast recovery. A suitable choice is the Motorola MBR0520. This is a 0.5A, 20V Schottky in a very small package that is 1.35mm high.

PC Board Layout

The component placement shown in Figure 1 is recommended for PC board layouts. The high speed current paths are kept to a minimum distance and the switch node copper is minimized to keep radiated noise low. Notice the placement of the input decoupling capacitor next to the IC. This is necessary for best performance.

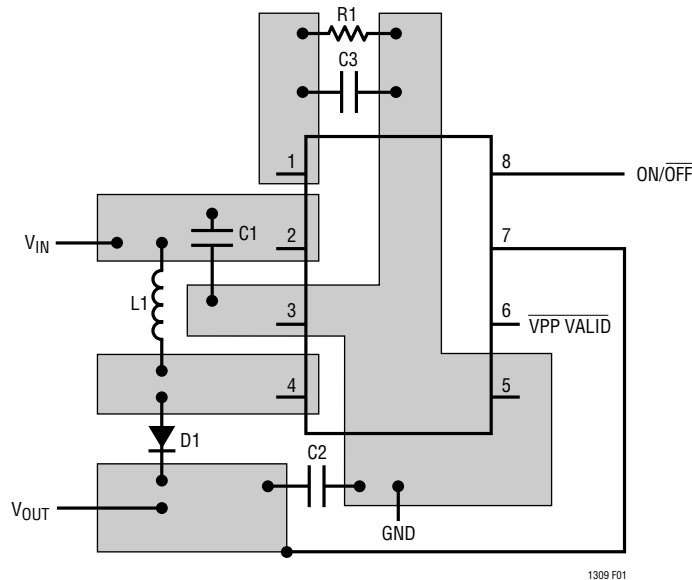
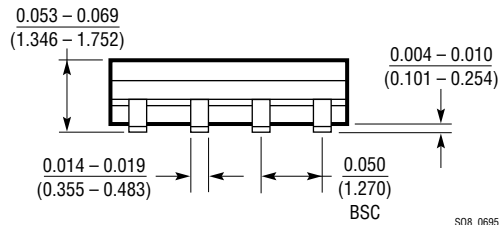
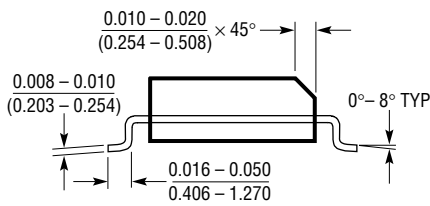
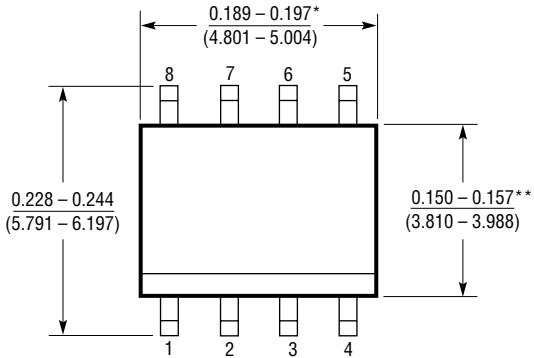

Figure 1. LT1309 Recommended Layout

PACKAGE DESCRIPTION Dimensions in inches (millimeters) unless otherwise noted.

S8 Package
8-Lead Plastic Small Outline (Narrow 0.150)
 (LTC DWG # 05-08-1610)



*DIMENSION DOES NOT INCLUDE MOLD FLASH. MOLD FLASH SHALL NOT EXCEED 0.006" (0.152mm) PER SIDE
 **DIMENSION DOES NOT INCLUDE INTERLEAD FLASH. INTERLEAD FLASH SHALL NOT EXCEED 0.010" (0.254mm) PER SIDE

S08 0695

RELATED PARTS

PART NUMBER	DESCRIPTION	COMMENTS
LT1106	Micropower Step-Up DC/DC Converter, 12V at 60mA	Thin TSSOP Package for Type I PCMCIA Card
LT1109-12	Micropower Step-Up DC/DC Converter, 12V at 60mA	Flash Memory VPP Generator, Adjustable Also
LT1109A-12	Micropower Step-Up DC/DC Converter, 12V at 120mA	VPP Generator, Adjustable Also
LTC®1262	Inductorless Flash Memory Programming Supply, 12V at 30mA	Switched Capacitor Converter, No Inductor
LT1303	Micropower High Efficiency DC/DC Converter with Low-Battery Detector	Adjustable and Fixed 5V, I _{OUT} up to 200mA