

4A, 2MHz Dual Phase Step-Up DC/DC Converter in 3mm × 3mm DFN

FEATURES

- **High Efficiency: Up to 92%**
- **2-Phase Control Reduces Output Voltage Ripple**
- **5V at 2A from 3.3V Input**
- **3.3V at 1.5A from 1.8V Input**
- 1.6V to 5.25V Adjustable Output Voltage
- 1.6V to 4.5V Input Range
- Internal Soft-Start Operation
- Low Shutdown Current: <math><1\mu\text{A}</math>
- Uses Small Surface Mount Components
- 10-Pin 3mm × 3mm DFN Package

APPLICATIONS

- Networking Equipment
- Handheld Instruments
- Digital Cameras
- Distributed Power
- Local 3.3V to 5V Conversion

DESCRIPTION

The LTC[®]3428 is a 2-phase, current mode boost converter, capable of supplying 2A at 5V from a 3.3V input. Two 93m Ω , 2A N-channel MOSFET switches allow the LTC3428 to deliver high efficiency from input voltages as low as 1.6V.

External parts count and size are minimized by a 1MHz switching frequency and a 2-phase design. Two phase operation significantly reduces peak inductor currents and capacitor ripple current, doubling the effective switching frequency and minimizing inductor and capacitor size. External compensation allows the feedback loop response to be optimized for a particular application.

Other features include: an active low shutdown pin reduces supply current to below 1 μA , internal soft-start, antiringing control and thermal shutdown. The LTC3428 is available in a low profile (0.75mm) 10-lead (3mm × 3mm) DFN package.

LT, LT, LTC and LTM are registered trademarks of Linear Technology Corporation. All other trademarks are the property of their respective owners.

TYPICAL APPLICATION

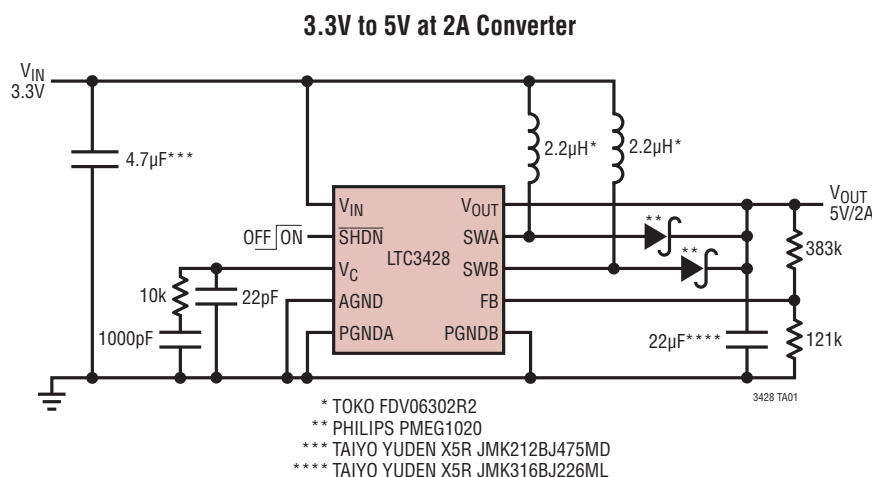

Efficiency vs Load Current

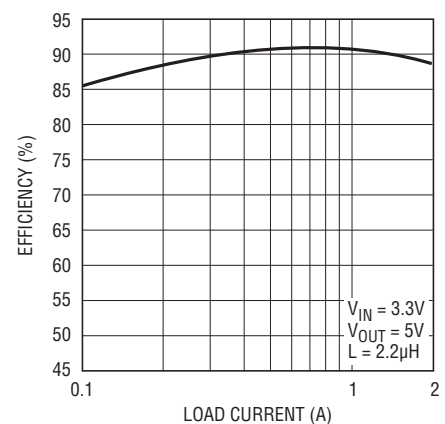

LTC3428

ABSOLUTE MAXIMUM RATINGS

(Note 1)

V_{IN} , V_{OUT} , SWA, SWB Voltage.....	-0.3 to 6V
SWA, SWB Voltage, Pulsed, <100ns.....	7V
\overline{SHDN} , V_C , FB Voltage	-0.3 to 6V
Operating Temperature Range (Note 2)....	-40°C to 85°C
Storage Temperature Range.....	-65°C to 125°C

PIN CONFIGURATION

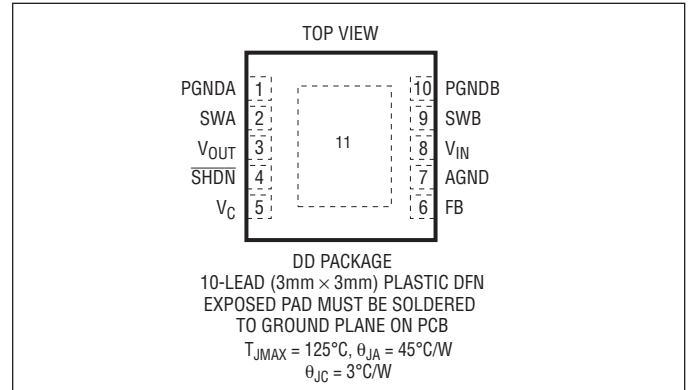

ORDER INFORMATION

LEAD FREE FINISH	TAPE AND REEL	PART MARKING	PACKAGE DESCRIPTION	TEMPERATURE RANGE
LTC3428EDD#PBF	LTC3428EDD#TRPBF	LBBG	10-Lead (3mm x 3mm) Plastic DFN	-40°C to 85°C
LEAD BASED FINISH	TAPE AND REEL	PART MARKING	PACKAGE DESCRIPTION	TEMPERATURE RANGE
LTC3428EDD	LTC3428EDD#TR	LBBG	10-Lead (3mm x 3mm) Plastic DFN	-40°C to 85°C

Consult LTC Marketing for parts specified with wider operating temperature ranges.

For more information on lead free part marking, go to: <http://www.linear.com/leadfree/>

For more information on tape and reel specifications, go to: <http://www.linear.com/tapeandreeel/>

ELECTRICAL CHARACTERISTICS

The ● denotes the specifications which apply over the full operating temperature range, otherwise specifications are at $T_A = 25^{\circ}\text{C}$. $V_{IN} = 3.3\text{V}$, $V_{OUT} = 5\text{V}$ unless otherwise noted.

PARAMETER	CONDITIONS	MIN	TYP	MAX	UNITS
Minimum Startup Voltage			1.5	1.6	V
Quiescent Current, V_{OUT}	$\overline{SHDN} = V_{IN}$		100	200	μA
Quiescent Current, V_{IN}	$\overline{SHDN} = V_{IN}$		1.3	2.0	mA
Shutdown Current	$\overline{SHDN} = 0\text{V}$			1	μA
Switching Frequency	Per Phase	● 0.8	1.0	1.2	MHz
FB Regulated Voltage		● 1.219	1.243	1.268	V
FB Input Current	$V_{FB} = 1.24\text{V}$		1	50	nA
Error Amp Transconductance			170		μS
Output Adjust Voltage		1.6		5.25	V

ELECTRICAL CHARACTERISTICS The ● denotes the specifications which apply over the full operating temperature range, otherwise specifications are at $T_A = 25^\circ\text{C}$. $V_{IN} = 3.3\text{V}$, $V_{OUT} = 5\text{V}$ unless otherwise noted.

PARAMETER	CONDITIONS	MIN	TYP	MAX	UNITS
NMOS Switch Leakage	$V_{SWA}, V_{SWB} = 5.5\text{V}$, Per Phase		0.1	2.5	μA
NMOS Switch On Resistance	$V_{OUT} = 5\text{V}$, Per Phase		0.093		Ω
NMOS Current Limit	Per Phase	● 2	2.5		A
SHDN Input Threshold		● 0.4	0.8	1.5	V
SHDN Input Current			0.01	1	μA
Maximum Duty Cycle		● 80	87		%
Minimum Duty Cycle		●		0	%
Current Limit Delay to Output	(Note 3)		400		ns

Note 1: Stresses beyond those listed under Absolute Maximum Ratings may cause permanent damage to the device. Exposure to any Absolute Maximum Rating condition for extended periods may affect device reliability and lifetime.

Note 2: The LTC3428E is guaranteed to meet performance specifications from 0°C to 70°C . Specifications over the -40°C to 85°C operating temperature range are assured by design, characterization and correlation with statistical process controls.

Note 3: Specification is guaranteed by design and not 100% tested in production.

Note 4: This IC includes overtemperature protection that is intended to protect the device during momentary overload conditions. Junction temperature will exceed 125°C when overtemperature protection is active. Continuous operation above the specified maximum operating junction temperature may impair device reliability.

TYPICAL PERFORMANCE CHARACTERISTICS

All characteristic curves at $T_A = 25^\circ\text{C}$ unless otherwise noted.

SWA, SWB Switching Waveforms

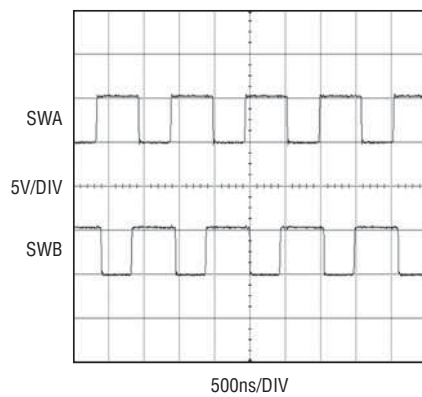

3428 G01

SW Pin and Inductor Current in Discontinuous Mode, Demonstrating Anti-Ring Circuit Operation

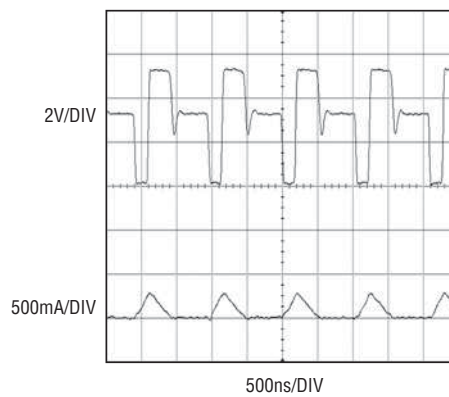

3428 G02

Transient Response, 0.5A to 1.5A

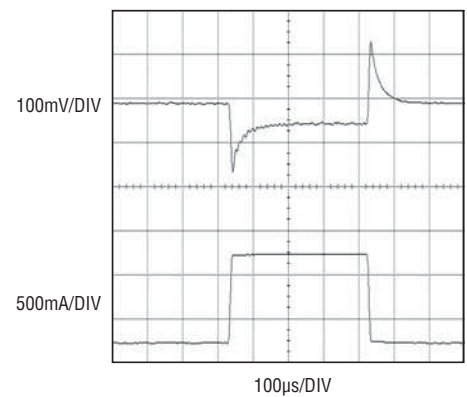

3428 G03

TYPICAL PERFORMANCE CHARACTERISTICS

All characteristic curves at $T_A = 25^\circ\text{C}$ unless otherwise noted.

Output Voltage Ripple with 22 μF Ceramic Capacitor

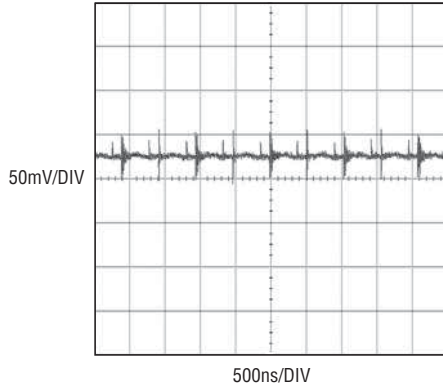

3428 G04

Converter Efficiency

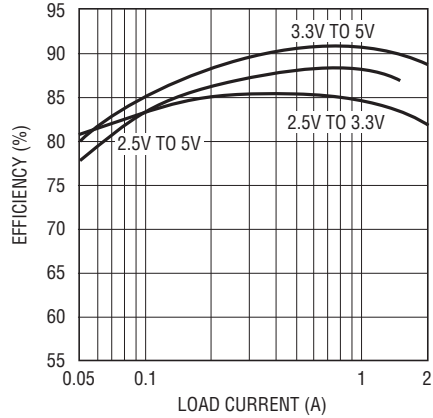

3428 G05

Switch $R_{DS(ON)}$ vs V_{OUT}

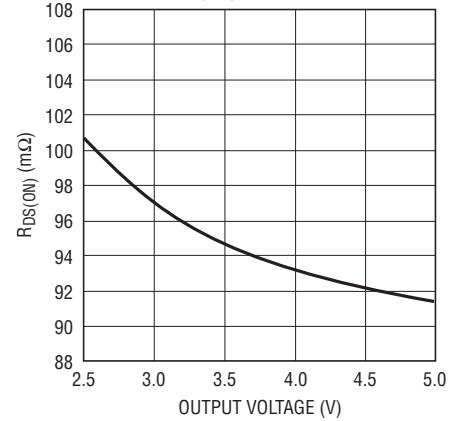

3428 G06

SWA, SWB Rise Time, $I = 2\text{A}$

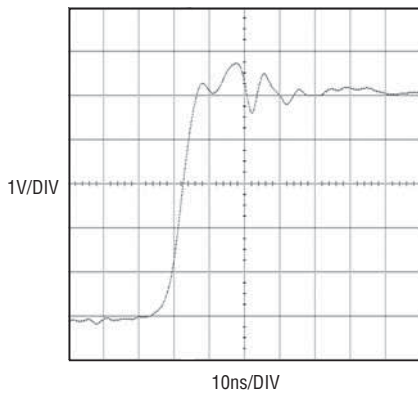

3428 G07

Switch $R_{DS(ON)}$ vs Temperature

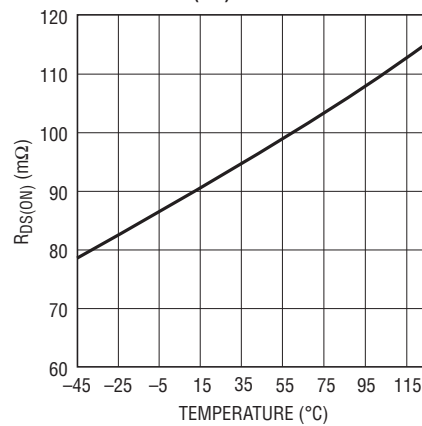

3428 G08

Feedback Voltage vs Temperature

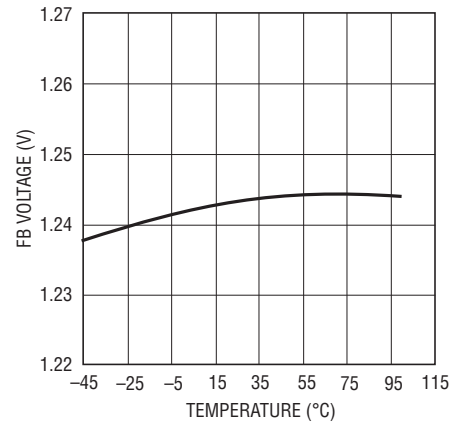

3428 G09

Peak Current Limit vs Temperature

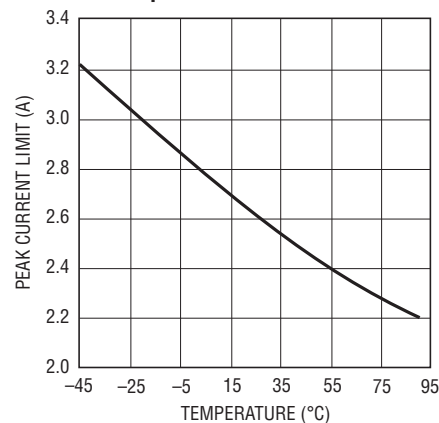

3428 G10

PIN FUNCTIONS

PGNDA, PGNDB (Pins 1, 10, 11 (Exposed Pad)): Power Ground for the IC. Tie directly to local ground plane.

SWA (Pin 2), SWB (Pin 9): Phase B and Phase A Switch Pins. The inductor and Schottky diodes for each phase are connected to these pins. Minimize trace length to reduce EMI.

V_{OUT} (Pin 3): Power Supply Output and Bootstrapped Power Source for the IC. Connect low ESR output filter capacitors from this pin to the ground plane.

SHDN (Pin 4): Shutdown Pin. Grounding this pin shuts down the IC. Connect to a voltage greater than 1.5V to enable.

V_C (Pin 5): Error Amp Output. A frequency compensation network is connected to this pin to compensate the boost converter loop.

FB (Pin 6): Feedback Pin. A resistor divider from V_{OUT} is connected here to set the output voltage according to $V_{OUT} = 1.243 \cdot (1 + R1 / R2)$

AGND (Pin 7): Signal Ground for the IC. Connect to ground plane near feedback resistor divider.

V_{IN} (Pin 8): Input Supply Pin. Bypass V_{IN} with a low ESR ceramic capacitor of at least 4.7μF. X5R and X7R dielectrics are preferred for their superior voltage and temperature characteristics.

BLOCK DIAGRAM

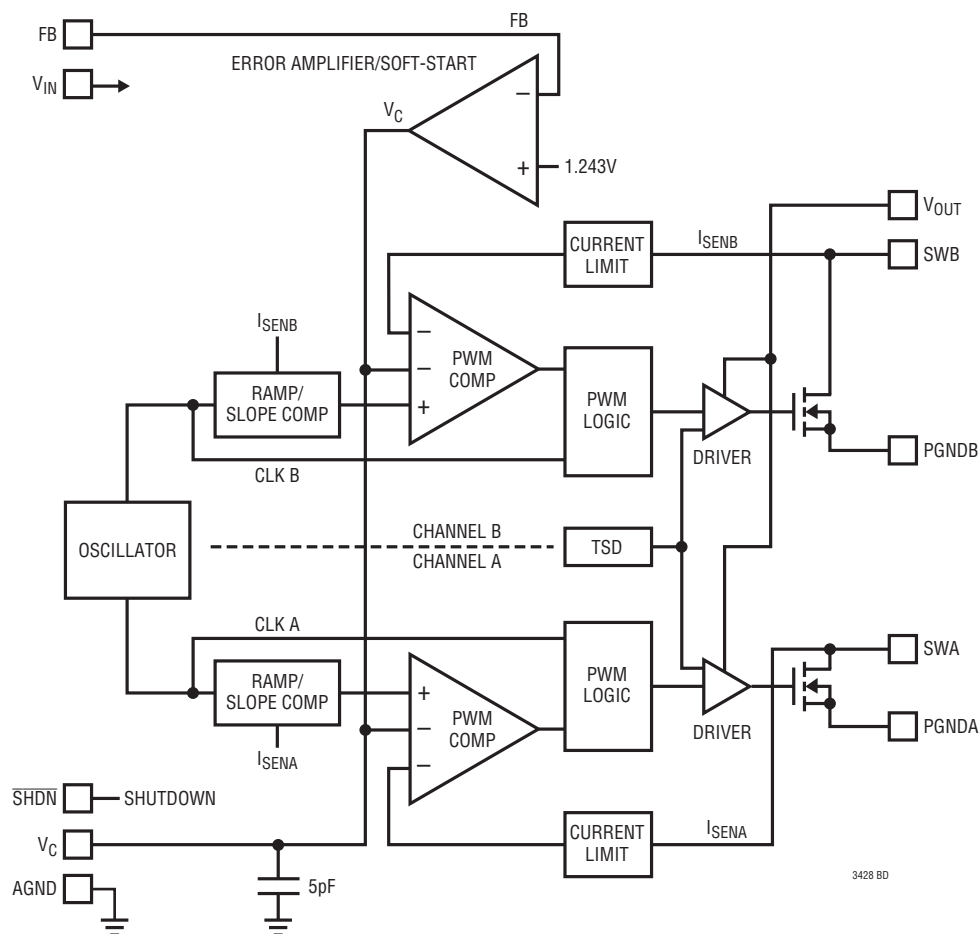

APPLICATIONS INFORMATION

DETAILED DESCRIPTION

The LTC3428 provides high efficiency, low noise power for high current boost applications. A current mode architecture with adaptive slope compensation provides both simple loop compensation as well as excellent transient response. The low $R_{DS(ON)}$ switches provide the pulse width modulation control at high efficiency.

Oscillator: The per phase switching frequency is internally set to a nominal value of 1MHz.

Current Sensing: Lossless current sensing converts the peak current signal to a voltage which is summed with the internal slope compensation. This summed signal is then compared with the error amplifier output to provide a peak current command for the PWM. Slope compensation is internal to the IC and adapts to changes to the input voltage, allowing the converter to provide the necessary degree of slope compensation without causing a loss in phase margin in the loop characteristic.

Error Amplifier: The error amplifier is a transconductance amplifier with a transconductance (g_m) = 1/5.9k Ω . A simple compensation network is placed from V_C to ground. The internal 5pF capacitor between V_C and ground will often simplify the external network to a simple R-C combination. The internal 1.243V reference voltage is compared to the voltage on FB to generate an error signal at the output of the error amplifier (V_C). A voltage divider from V_{OUT} to ground programs the output voltage from 1.6V to 5.25V using the equation:

$$V_{OUT} = 1.243V \cdot (1 + R1/R2)$$

Soft-Start: Where R1 and R2 are shown in Figure 3. An internal soft-start of approximately 1.5ms is provided. This is a ramp signal that limits the peak current until the internal soft-start voltage is greater than the internal current limit voltage. The internal soft-start capacitor is automatically discharged when the part is in shutdown mode.

Current Limit: The current limit comparator in each phase will shut off the N-channel MOSFET switches once the current exceeds the current limit threshold, nominally 2.5A. The current limit delay to output is typically 40ns. The current signal leading edge is blanked for 40ns to enhance noise rejection.

Anti-Ringing Control: The antiringing control places an impedance across the inductor of each phase to damp the high frequency ringing on the SWA, SWB pins during discontinuous mode operation. The LC ringing on the switch pin due to the inductor and switch pin capacitance is low energy, but can cause EMI radiation.

2-Phase Operation

The LTC3428 uses a two-phase architecture, rather than the conventional single phase architecture used in most other boost converters. The two phases are spaced 180° apart. Two phase operation doubles the output ripple frequency and provides a significant reduction in output ripple current, minimizing the stress on the output capacitor. Inductor (input) peak and ripple currents are also reduced, allowing for the use of smaller, lower cost inductors. The greatly reduced output ripple current also minimizes the output capacitance requirement. The higher frequency output ripple is easier to filter for lower noise applications.

Input and output current comparisons for single and 2-phase converters are illustrated in Figures 1 and 2.

For the example illustrated in Figure 2, peak-to-peak output ripple current was reduced by 85%, from 4.34A, to 0.64A, and peak inductor current was reduced by 53%, from 4.34A to 2.02A. These reductions enable the use of low profile, smaller valued inductors and output capacitors as compared to a single-phase design.

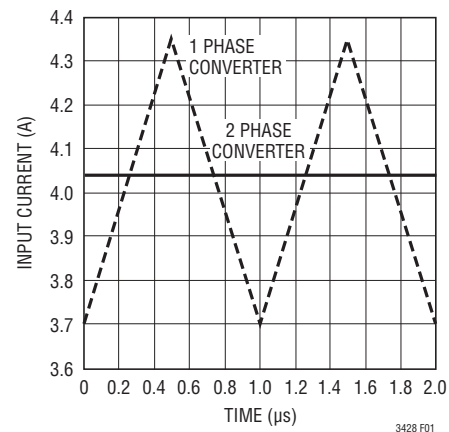

Figure 1. Input Ripple Current Comparison Between Single Phase and Two-Phase Boost Converters with a 2A Load and 50% Duty Cycle

APPLICATIONS INFORMATION

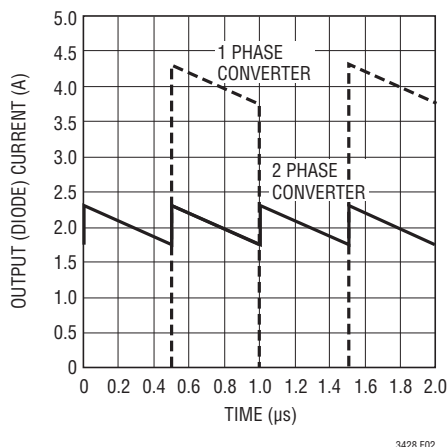

Figure 2. Output Ripple Current Comparison Between Single Phase and Two Phase Boost Converters with a 2A Load and 50% Duty Cycle

COMPONENT SELECTION

Inductor Selection

The high frequency operation of the LTC3428 allows for the use of small surface mount inductors. The inductor ripple current is typically set to between 20% and 40% of the maximum inductor current. For a given set of conditions, the inductance is given as follows:

$$L \geq \frac{V_{IN(MIN)} \cdot (V_{OUT} - V_{IN(MIN)})}{R \cdot V_{OUT}}, L > 2\mu\text{H}$$

where:

R = Allowable inductor current ripple (Amps P-P)

$V_{IN(MIN)}$ = Minimum input voltage (V)

V_{OUT} = Output voltage (V)

For high efficiency, the inductor should have a high frequency core material, such as ferrite, to reduce core losses. The inductor should have a low ESR (equivalent series resistance) to reduce I^2R losses and must be able to handle the peak inductor current without saturating. Use of a toroid, pot core, or shielded bobbin inductor will minimize radiated noise. See Table 1 for a list of inductor manufacturers. Some example inductor part types are: Coilcraft 1608 and 3316 series, Murata LQH55D series,

Sumida CDRH4D22C/LD or CDRH5D28 series, Toko FDV0630 or D62CB series.

Table 1. Inductor Vendor Information

SUPPLIER	PHONE	FAX	WEBSITE
Coilcraft	(847) 639-6400	(847) 639-1469	www.coilcraft.com
Murata	USA: (814) 238-1431	USA: (814) 238-0490	www.murata.com
Sumida	USA: (847) 956-6666 Japan: 81-3-3607-5111	USA: (847) 956-0702 Japan: 81-3-3607-5144	www.sumida.com
TDK	(847) 803-6100	(847) 803-6296	www.component.tdk.com
Toko	(847) 299-0070	(847) 699-7864	www.toko.com
Würth	(201)785-8800	(201)785-8810	www.we-online.com

Output Capacitor Selection

The minimum value of the capacitor is set to reduce the output ripple voltage due to charging and discharging the capacitor each cycle. The steady state ripple due to this charging is given by:

$$V_{RIPPLE(C)} = \frac{1}{2} \cdot \frac{I_{PEAK} \cdot (V_{OUT} - V_{IN(MIN)})}{C_{OUT} \cdot V_{OUT} \cdot f}$$

where: I_{PEAK} = Peak inductor current (A)

The equivalent series resistance (ESR) of the output capacitor will contribute another term to output voltage ripple. Ripple voltage due to capacitor ESR is:

$$V_{RIPPLE(ESR)} = I_{PEAK} \cdot R_{ESR(C)}$$

where:

$R_{ESR(C)}$ = Capacitor ESR

The ESL (Equivalent Series Inductance) is another capacitor characteristic that needs to be minimized. ESL will be minimized by using small surface mount ceramic capacitors, placed as close to the V_{OUT} pin as possible.

Input Capacitor Selection

Since the V_{IN} pin directly powers most of the internal circuitry, it is recommended to place at least a 4.7 μF , low ESR bypass capacitor between V_{IN} and AGND, as close to the IC as possible. See Table 2 for a list of capacitor manufacturers.

APPLICATIONS INFORMATION

Table 2. Capacitor Vendor Information

SUPPLIER	PHONE	FAX	WEBSITE
AVX	(803) 448-9411	(803) 448-1943	www.avxcorp.com
Sanyo	(619) 661-9322	(619) 661-1055	www.sanyovideo.com
TDK	(847) 803-6100	(847) 803-6296	www.component.tdk.com
Murata	(814) 237-1431	(814) 238-0490	www.murata.com
Taiyo Yuden	(408) 573-4150	(408) 573-4159	www.t-yuden.com

Output Diode Selection

For high efficiency, a fast switching diode with low reverse leakage and a low forward drop is required. Schottky diodes are recommended for their low forward drop and fast switching times. When selecting a diode, it is important to remember that the average diode current in a boost converter is equal to the average load current: $I_D = I_{LOAD}$

When selecting a diode, make sure that the peak forward current and average power dissipation ratings meet the application requirements. See Table 3 for a list of Schottky diode manufacturers. Example diodes are Philips PMEG1020, PMEG2010, On-Semi MBRA210, IR 10BQ015, Microsemi UPS120E, UPS315.

Table 3. Diode Vendor Information

SUPPLIER	PHONE	FAX	WEBSITE
Philips	+31 40 27 24825		www.philips.com
Microsemi	(949) 221-7100	(949)756-0308	www.microsemi.com
On-Semi	(602) 244-6600		www.microsemi.com
International Rectifier	(310) 469-2161	(310) 322-3332	www.irf.com

Thermal Considerations

To deliver maximum power, it is necessary to provide a good thermal path to dissipate the heat generated within the LTC3428's package. The large thermal pad on the IC underside can accomplish this requirement. Use multiple PC board vias to conduct heat from the IC and to a copper plane that has as much area as possible.

If the junction temperature gets too high, the LTC3428 will stop all switching until the junction temperature drops to safe levels. The typical over temperature threshold is 150°C.

Closing the Feedback Loop

The LTC3428 uses current mode control with internal, adaptive slope compensation. Current mode control eliminates the 2nd order pole in the loop response of voltage mode converters due to the inductor and output capacitor, simplifying it to a single pole response. The product of the modulator control to output DC gain and the error amp open-loop gain equals the DC gain of the system.

$$G_{DC} = G_{CONTROL} \cdot G_{EA} \cdot \frac{V_{REF}}{V_{OUT}}$$

$$G_{CONTROL} = \frac{2 \cdot V_{IN}}{I_{OUT}}$$

$$G_{EA} \approx 100$$

The output filter pole is given by:

$$f_{POLE} = \frac{I_{OUT}}{\pi \cdot V_{OUT} \cdot C_{OUT}} \text{ Hz}$$

where C_{OUT} is the output filter capacitor value. The output filter zero is given by:

$$f_{ZERO} = \frac{1}{2 \cdot \pi \cdot R_{ESR} \cdot C_{OUT}} \text{ Hz}$$

where R_{ESR} is the output capacitor equivalent series resistance.

A complication of the boost converter topology is the right half plane (RHP) zero and is given by:

$$f_{RHP} = \frac{V_{IN}^2 \cdot R_O}{2 \cdot \pi \cdot L \cdot V_O^2} \text{ Hz}$$

APPLICATIONS INFORMATION

This zero causes a gain increase with phase lag. With heavy loads, this can occur at a relatively low frequency. For this reason, loop gain is typically rolled off below the RHP zero frequency.

A typical error amp compensation is shown in Figure 3 and in the Typical Application section.

The equations for the loop dynamics are as follow:

$$f_{\text{POLE1}} \approx \frac{1}{2 \cdot \pi \cdot 400e6 \cdot C_{C1}}$$

$$f_{\text{ZERO1}} \approx \frac{1}{2 \cdot \pi \cdot R_Z \cdot C_{C1}}$$

$$f_{\text{ZERO2}} \approx \frac{1}{2 \cdot \pi \cdot R_Z \cdot (C_{C2} + 5pF)}$$

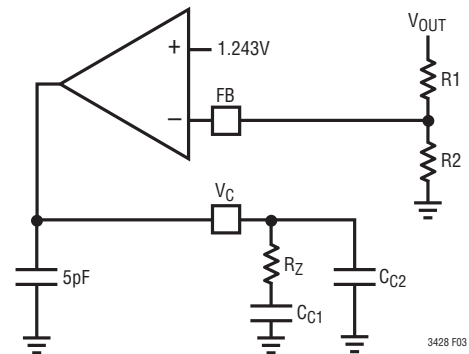
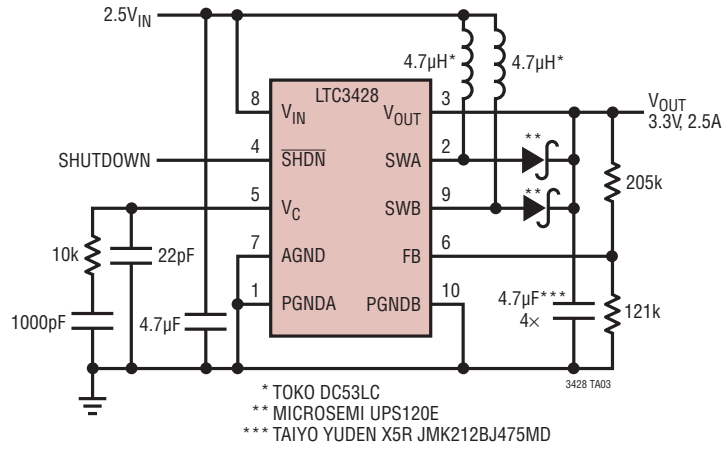

Figure 3.

TYPICAL APPLICATION

2.5V to 3.3V at 2.5A Converter



RELATED PARTS

PART NUMBER	DESCRIPTION	COMMENTS
LT1613	550mA (I_{SW}), 1.4MHz, High Efficiency Step-Up DC/DC Converter	90% Efficiency, V_{IN} : 0.9V to 10V, $V_{OUT(MAX)}$ = 34V, I_Q = 3mA, I_{SD} < 1 μ A, ThinSOT Package
LT1615/LT1615-1	300mA/80mA (I_{SW}), High Efficiency Step-Up DC/DC Converter	V_{IN} : 1V to 15V, $V_{OUT(MAX)}$ = 34V, I_Q = 20 μ A, I_{SD} < 1 μ A, ThinSOT Package
LT1618	1.5A (I_{SW}), 1.25MHz, High Efficiency Step-Up DC/DC Converter	90% Efficiency, V_{IN} : 1.6V to 18V, $V_{OUT(MAX)}$ = 35V, I_Q = 1.8mA, I_{SD} < 1 μ A, MS Package
LT1930/LT1930A	1A (I_{SW}), 1.2MHz/2.2MHz, High Efficiency Step-Up DC/DC Converter	High Efficiency, V_{IN} : 2.6V to 16V, $V_{OUT(MAX)}$ = 34V, I_Q = 4.2mA/5.5mA, I_{SD} < 1 μ A, ThinSOT Package
LT1946/LT1946A	1.5A (I_{SW}), 1.2MHz/2.7MHz, High Efficiency Step-Up DC/DC Converter	High Efficiency, V_{IN} : 2.45V to 16V, $V_{OUT(MAX)}$ = 34V, I_Q = 3.2mA, I_{SD} < 1 μ A, MS8 Package
LT1961	1.5A (I_{SW}), 1.25MHz, High Efficiency Step-Up DC/DC Converter	90% Efficiency, V_{IN} : 3V to 25V, $V_{OUT(MAX)}$ = 35V, I_Q = 0.9mA, I_{SD} 6 μ A, MS8E Package
LTC3400/LTC3400B	600mA (I_{SW}), 1.2MHz, Synchronous Step-Up DC/DC Converter	92% Efficiency, V_{IN} : 0.85V to 5V, $V_{OUT(MAX)}$ = 5V, I_Q = 19 μ A/300 μ A, I_{SD} < 1 μ A, ThinSOT Package
LTC3401	1A (I_{SW}), 3MHz, Synchronous Step-Up DC/DC Converter	97% Efficiency, V_{IN} : 0.5V to 5V, $V_{OUT(MAX)}$ = 5.5V, I_Q = 38 μ A, I_{SD} < 1 μ A, MS Package
LTC3402	2A (I_{SW}), 3MHz, Synchronous Step-Up DC/DC Converter	97% Efficiency, V_{IN} : 0.5V to 5V, $V_{OUT(MAX)}$ = 5.5V, I_Q = 38 μ A, I_{SD} < 1 μ A, MS Package
LTC3421	3A, 3MHz Synchronous Boost Converter with Output Disconnect	96% Efficiency, V_{IN} : 0.5V to 4.5V, $V_{OUT(MAX)}$ = 5.5V, I_Q = 12 μ A, I_{SD} < 1 μ A, QFN-24 Package
LTC3425	5A (I_{SW}), 8MHz, 4-Phase Synchronous Step-Up DC/DC Converter	95% Efficiency, V_{IN} : 0.5V to 4.5V, $V_{OUT(MAX)}$ = 5.25V, I_Q = 12 μ A, I_{SD} < 1 μ A, QFN-32 Package
LTC3426	2A, 1MHz Step-Up DC/DC Converter in ThinSOT	91% Efficiency, V_{IN} : 0.5V to 4.5V, $V_{OUT(MAX)}$ = 5.25V, I_{SD} < 1 μ A, SOTL3 Package
LTC3429	600mA, 500kHz Synchronous Boost Converter with Output Disconnect	96% Efficiency, V_{IN} : 0.5V to 4.4V, $V_{OUT(MAX)}$ = 5.5V, I_Q = 20 μ A, I_{SD} < 1 μ A, ThinSOT Package
LTC3436	3A (I_{SW}), 1MHz, 34V Step-Up DC/DC Converter	V_{IN} : 3V to 25V, $V_{OUT(MAX)}$ = 34V, I_Q = 0.9mA, I_{SD} < 6 μ A, TSSOP-16E Package
LTC3458	1.5A, 1.5MHz Step-Up DC/DC Converter with Output Disconnect	93% Efficiency V_{IN} : 1.2V to 6V, $V_{OUT(MAX)}$ = 7.5V, I_Q = 15 μ A, I_{SD} < 1 μ A, DFN-12 Package
LTC3458L	1.7A 1.5MHz Step-Up DC/DC Converter with Output Disconnect	93% Efficiency V_{IN} : 1.2V to 6V, $V_{OUT(MAX)}$ = 6V, I_Q = 15 μ A, I_{SD} < 1 μ A, DFN-12 Package
LTC3459	10V Micropower Synchronous Boost Converter	85% Efficiency, V_{IN} : 1.5V to 5.5V, $V_{OUT(MAX)}$ = 10V, I_Q = 10 μ A, I_{SD} < 1 μ A, ThinSOT Package
LT3464	85mA (I_{SW}), High Efficiency Step-Up DC/DC Converter with Integrated Schottky and PNP Disconnect	V_{IN} : 2.3V to 10V, $V_{OUT(MAX)}$ = 34V, I_Q = 25 μ A, I_{SD} < 1 μ A, ThinSOT Package

No R_{SENSE} is a registered trademark of Linear Technology Corporation.