

# Dual Synchronous, 800mA, 2.25MHz Step-Down DC/DC Regulator

## FEATURES

- **High Efficiency: Up to 95%**
- **Very Low Quiescent Current: Only 40µA**
- **2.25MHz Constant-Frequency Operation**
- **High Switch Current: 1.2A on Each Channel**
- **No Schottky Diodes Required**
- **Low  $R_{DS(ON)}$  Internal Switches: 0.35Ω**
- **Current Mode Operation for Excellent Line and Load Transient Response**
- **Short-Circuit Protected**
- **Low Dropout Operation: 100% Duty Cycle**
- **Ultralow Shutdown Current:  $I_Q < 1\mu A$**
- **Output Voltages from 5V down to 0.6V**
- **Power-On Reset Output**
- **Externally Synchronizable Oscillator**
- **Small Thermally Enhanced MSOP and 3mm × 3mm DFN Packages**

## APPLICATIONS

- PDAs/Palmtop PCs
- Digital Cameras
- Cellular Phones
- Portable Media Players
- PC Cards
- Wireless and DSL Modems

## DESCRIPTION

The LTC<sup>®</sup>3407-2 is a dual, constant-frequency, synchronous step down DC/DC converter. Intended for low power applications, it operates from 2.5V to 5.5V input voltage range and has a constant 2.25MHz switching frequency, allowing the use of tiny, low cost capacitors and inductors with a profile  $\leq 1.2\text{mm}$ . Each output voltage is adjustable from 0.6V to 5V. Internal synchronous 0.35Ω, 1.2A power switches provide high efficiency without the need for external Schottky diodes.

A user selectable mode input is provided to allow the user to trade-off noise ripple for low power efficiency. Burst Mode<sup>®</sup> operation provides high efficiency at light loads, while pulse-skipping mode provides low noise ripple at light loads.

To further maximize battery life, the P-channel MOSFETs are turned on continuously in dropout (100% duty cycle), and both channels draw a total quiescent current of only 40µA. In shutdown, the device draws  $< 1\mu A$ .

LT, LT, LTC, LTM, Burst Mode, Linear Technology and the Linear logo are registered trademarks of Linear Technology Corporation. All other trademarks are the property of their respective owners.

## TYPICAL APPLICATION

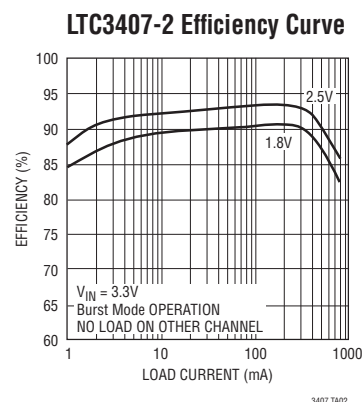
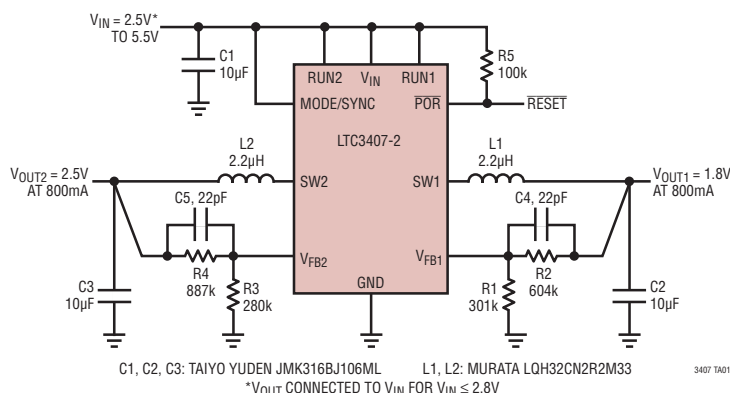

Figure 1. 2.5V/1.8V at 800mA Step-Down Regulators

# LTC3407-2

## ABSOLUTE MAXIMUM RATINGS (Note 1)

$V_{IN}$ Voltages .....	-0.3V to 6V	Ambient Operating Temperature Range (Note 2)	
$V_{FB1}$ , $V_{FB2}$ Voltages .....	-0.3V to $V_{IN} + 0.3V$	LTC3407E-2 .....	-40°C to 85°C
RUN1, RUN2 Voltages .....	-0.3V to $V_{IN}$	LTC3407I-2 .....	-40°C to 125°C
MODE/SYNC Voltage.....	-0.3V to $V_{IN} + 0.3V$	Junction Temperature (Note 5) .....	125°C
SW1, SW2 Voltage.....	-0.3V to $V_{IN} + 0.3V$	Storage Temperature Range.....	-65°C to 150°C
POR Voltage.....	-0.3V to 6V	Lead Temperature (Soldering, 10 sec)	
		MSE Package Only .....	300°C
		Reflow Peak Body Temperature .....	260°C

## PIN CONFIGURATION

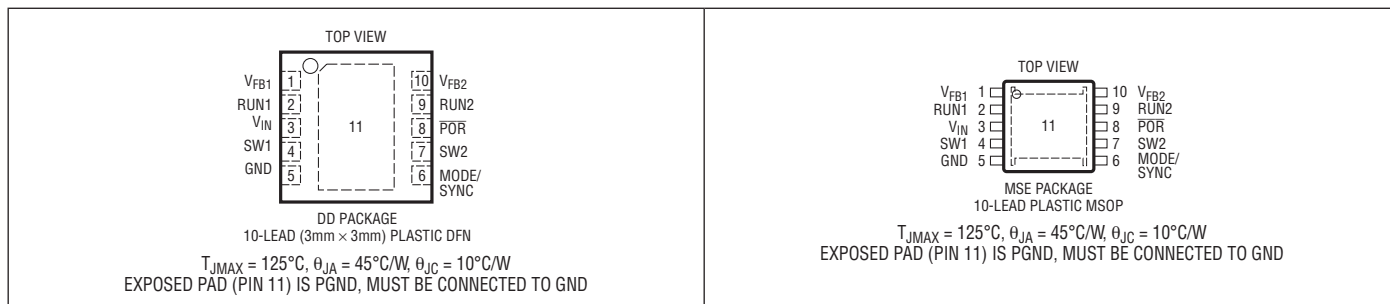

## ORDER INFORMATION

LEAD FREE FINISH	TAPE AND REEL	PART MARKING*	PACKAGE DESCRIPTION	TEMPERATURE RANGE
LTC3407EDD-2#PBF	LTC3407EDD-2#TRPBF	LBFB	10-Lead (3mm x 3mm) Plastic DFN	-40°C to 85°C
LTC3407IDD-2#PBF	LTC3407IDD-2#TRPBF	LBFB	10-Lead (3mm x 3mm) Plastic DFN	-40°C to 125°C
LTC3407EMSE-2#PBF	LTC3407EMSE-2#TRPBF	LTBDZ	10-Lead Plastic MSOP	-40°C to 85°C
LTC3407IMSE-2#PBF	LTC3407IMSE-2#TRPBF	LTBDZ	10-Lead Plastic MSOP	-40°C to 125°C
LEAD BASED FINISH	TAPE AND REEL	PART MARKING*	PACKAGE DESCRIPTION	TEMPERATURE RANGE
LTC3407EDD-2	LTC3407EDD-2#TR	LBFB	10-Lead (3mm x 3mm) Plastic DFN	-40°C to 85°C
LTC3407IDD-2	LTC3407IDD-2#TR	LBFB	10-Lead (3mm x 3mm) Plastic DFN	-40°C to 125°C
LTC3407EMSE-2	LTC3407EMSE-2#TR	LTBDZ	10-Lead Plastic MSOP	-40°C to 85°C
LTC3407IMSE-2	LTC3407IMSE-2#TR	LTBDZ	10-Lead Plastic MSOP	-40°C to 125°C

Consult LTC Marketing for parts specified with wider operating temperature ranges. \*The temperature grade is identified by a label on the shipping container.

For more information on lead free part marking, go to: <http://www.linear.com/leadfree/>

For more information on tape and reel specifications, go to: <http://www.linear.com/tapeandreeel/>

## ELECTRICAL CHARACTERISTICS

The ● denotes the specifications which apply over the full operating temperature range, otherwise specifications are at  $T_A = 25^\circ\text{C}$ .  $V_{IN} = 3.6\text{V}$ , unless otherwise specified. (Note 2)

SYMBOL	PARAMETER	CONDITIONS	MIN	TYP	MAX	UNITS
$V_{IN}$	Operating Voltage Range	●	2.5		5.5	V
$I_{FB}$	Feedback Pin Input Current	●			30	nA

34072fc

**ELECTRICAL CHARACTERISTICS** The ● denotes the specifications which apply over the full operating temperature range, otherwise specifications are at  $T_A = 25^\circ\text{C}$ .  $V_{IN} = 3.6\text{V}$ , unless otherwise specified. (Note 2)

SYMBOL	PARAMETER	CONDITIONS	MIN	TYP	MAX	UNITS
$V_{FB}$	Feedback Voltage (Note 3)	$0^\circ\text{C} \leq T_A \leq 85^\circ\text{C}$	0.588	0.6	0.612	V
		$-40^\circ\text{C} \leq T_A \leq 85^\circ\text{C}$	● 0.585	0.6	0.612	V
		$-40^\circ\text{C} \leq T_A \leq 125^\circ\text{C}$ (Note 2)	● 0.585	0.6	0.612	V
$\Delta V_{LINE REG}$	Reference Voltage Line Regulation	$V_{IN} = 2.5\text{V}$ to $5.5\text{V}$ (Note 3)		0.3	0.5	%/V
$\Delta V_{LOAD REG}$	Output Voltage Load Regulation	(Note 3)		0.5		%
$I_S$	Input DC Supply Current	Active Mode		700	950	$\mu\text{A}$
		Sleep Mode		40	60	$\mu\text{A}$
		Shutdown		0.1	1	$\mu\text{A}$
		(Note 4) $V_{FB1} = V_{FB2} = 0.5\text{V}$ $V_{FB1} = V_{FB2} = 0.63\text{V}$ , MODE/SYNC = 3.6V RUN = 0V, $V_{IN} = 5.5\text{V}$ , MODE/SYNC = 0V				
$f_{OSC}$	Oscillator Frequency	$V_{FBX} = 0.6\text{V}$	● 1.8	2.25	2.7	MHz
$f_{SYNC}$	Synchronization Frequency			2.25		MHz
$I_{LIM}$	Peak Switch Current Limit	$V_{IN} = 3\text{V}$ , $V_{FBX} = 0.5\text{V}$ , Duty Cycle <35%	0.95	1.2	1.6	A
$R_{DS(ON)}$	Top Switch On-Resistance Bottom Switch On-Resistance	(Note 6)		0.35	0.45	$\Omega$
		(Note 6)		0.30	0.45	$\Omega$
$I_{SW(LKG)}$	Switch Leakage Current	$V_{IN} = 5\text{V}$ , $V_{RUN} = 0\text{V}$ , $V_{FBX} = 0\text{V}$		0.01	1	$\mu\text{A}$
POR	Power-On Reset Threshold	$V_{FBX}$ Ramping Up, MODE/SYNC = 0V		8.5		%
		$V_{FBX}$ Ramping Down, MODE/SYNC = 0V		-8.5		%
		Power-On Reset On-Resistance			100	200
	Power-On Reset Delay			262,144		Cycles
$V_{RUN}$	RUN Threshold		● 0.3	1	1.5	V
$I_{RUN}$	RUN Leakage Current		●	0.01	1	$\mu\text{A}$
$V_{MODE}$	Mode Threshold Low		0		0.5	V
	Mode Threshold High		$V_{IN} - 0.5$		$V_{IN}$	V

**Note 1:** Stresses beyond those listed under Absolute Maximum Ratings may cause permanent damage to the device. Exposure to any Absolute Maximum Rating condition for extended periods may affect device reliability and lifetime.

**Note 2:** The LTC3407E-2 is guaranteed to meet specified performance from  $0^\circ\text{C}$  to  $70^\circ\text{C}$ . Specifications over the  $-40^\circ\text{C}$  to  $85^\circ\text{C}$  operating temperature range are assured by design, characterization and correlation with statistical process controls. The LTC3407I-2 is guaranteed over the full  $-40^\circ\text{C}$  to  $125^\circ\text{C}$  operating temperature range.

**Note 3:** The LTC3407-2 is tested in a proprietary test mode that connects  $V_{FB}$  to the output of the error amplifier.

**Note 4:** Dynamic supply current is higher due to the internal gate charge being delivered at the switching frequency.

**Note 5:**  $T_J$  is calculated from the ambient  $T_A$  and power dissipation  $P_D$  according to the following formula:  $T_J = T_A + (P_D \cdot \theta_{JA})$ .

**Note 6:** The DFN switch on-resistance is guaranteed by correlation to wafer level measurements.

**TYPICAL PERFORMANCE CHARACTERISTICS**  $T_A = 25^\circ\text{C}$  unless otherwise specified.

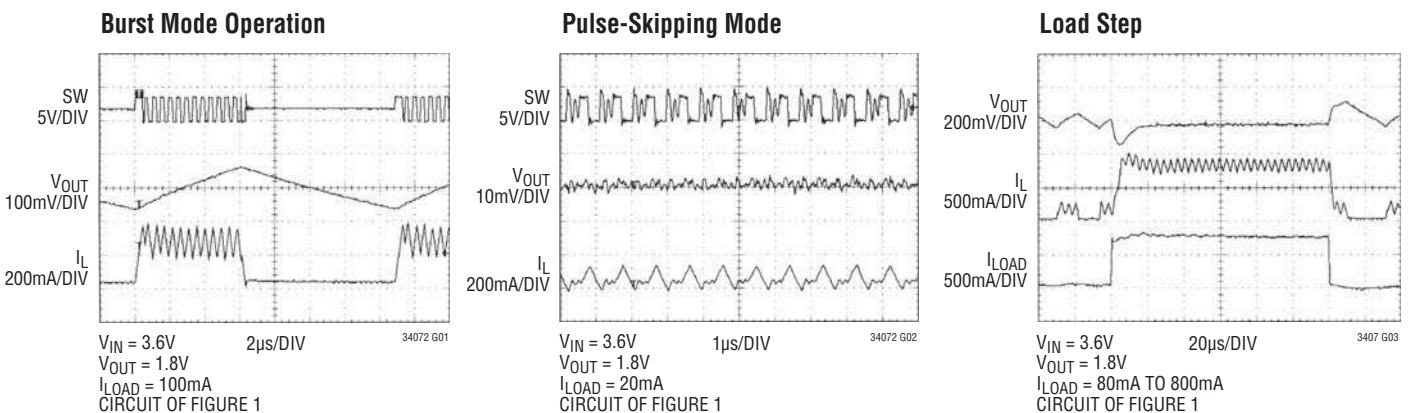

34072fc

## TYPICAL PERFORMANCE CHARACTERISTICS $T_A = 25^\circ\text{C}$ unless otherwise specified.

### Efficiency vs Input Voltage

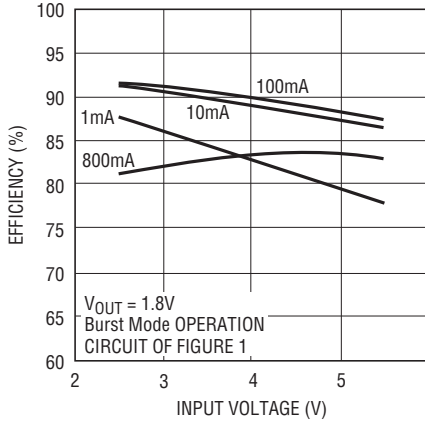

3407 G04

### Oscillator Frequency vs Temperature

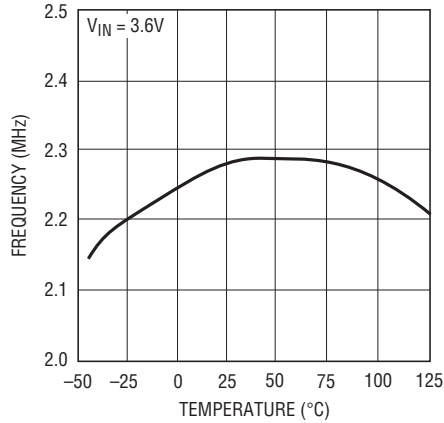

3407 G05

### Oscillator Frequency vs Supply Voltage

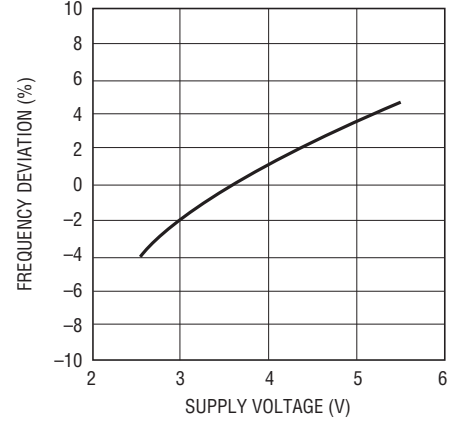

3407 G06

### Reference Voltage vs Temperature

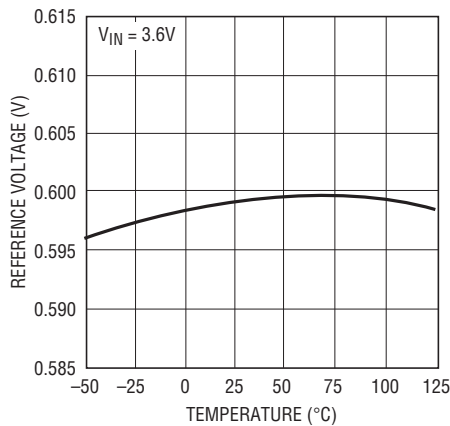

3407 G07

### $R_{DS(ON)}$ vs Input Voltage

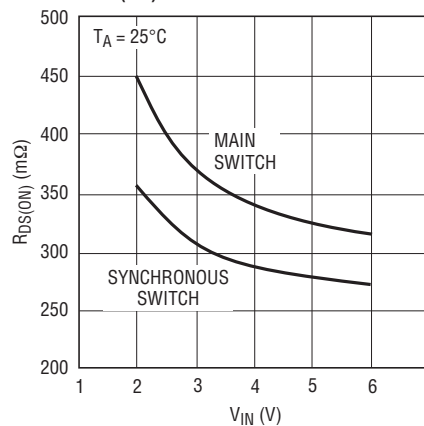

3407 G08

### $R_{DS(ON)}$ vs Temperature

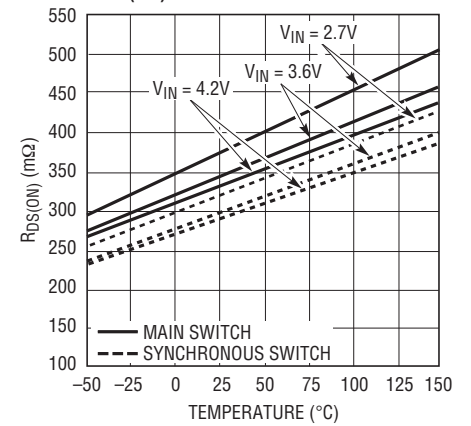

3407 G09

### Efficiency vs Load Current

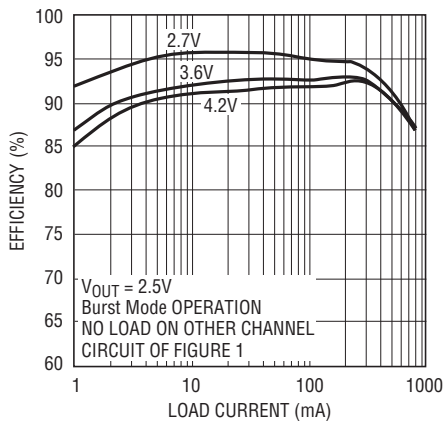

3407 G10

### Efficiency vs Load Current

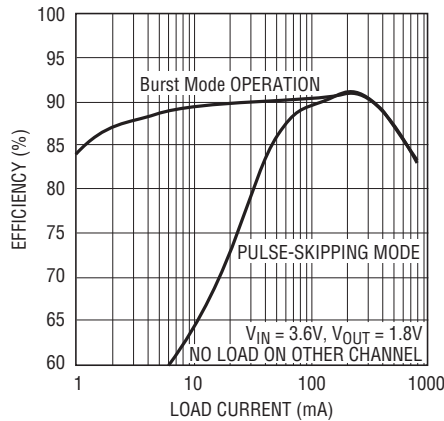

3407 G11

### Load Regulation

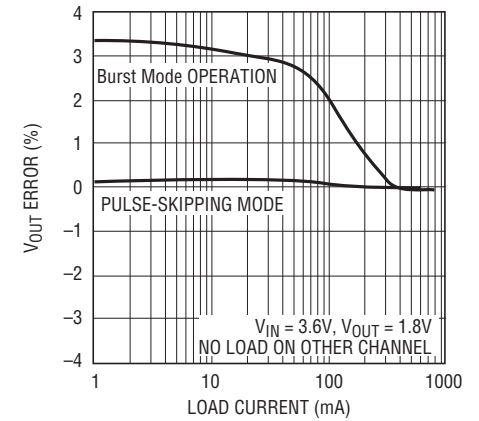

3407 G12

## TYPICAL PERFORMANCE CHARACTERISTICS $T_A = 25^\circ\text{C}$ unless otherwise specified.

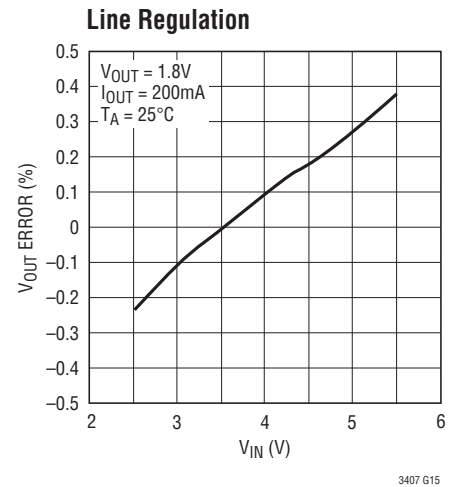
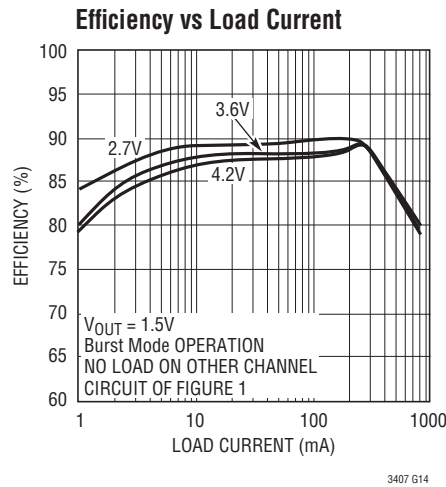
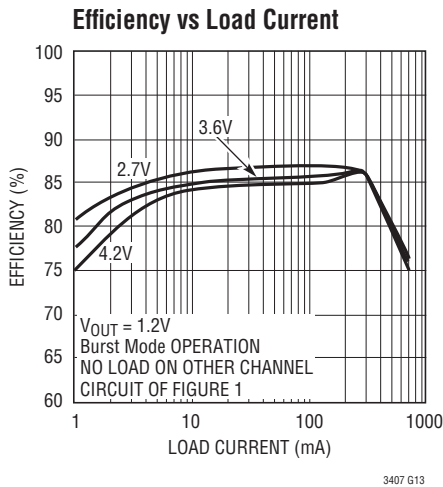

## PIN FUNCTIONS

**$V_{FB1}$  (Pin 1):** Output Feedback. Receives the feedback voltage from the external resistive divider across the output. Nominal voltage for this pin is 0.6V.

**$RUN1$  (Pin 2):** Regulator 1 Enable. Forcing this pin to  $V_{IN}$  enables regulator 1, while forcing it to GND causes regulator 1 to shut down. This pin must be driven; do not float.

**$V_{IN}$  (Pin 3):** Main Power Supply. Must be closely decoupled to GND.

**$SW1$  (Pin 4):** Regulator 1 Switch Node Connection to the Inductor. This pin swings from  $V_{IN}$  to GND.

**GND (Pin 5):** Ground. This pin is not connected internally. Connect to PCB ground for shielding.

**MODE/SYNC (Pin 6):** Combination Mode Selection and Oscillator Synchronization. This pin controls the operation of the device. When tied to  $V_{IN}$  or GND, Burst Mode operation or pulse-skipping mode is selected, respectively. Do not float this pin. The oscillation frequency can be

synchronized to an external oscillator applied to this pin and pulse-skipping mode is automatically selected.

**$SW2$  (Pin 7):** Regulator 2 Switch Node Connection to the Inductor. This pin swings from  $V_{IN}$  to GND.

**$\overline{POR}$  (Pin 8):** Power-On Reset. This common-drain logic output is pulled to GND when the output voltage is not within  $\pm 8.5\%$  of regulation and goes high after 117ms when both  $s$  are within regulation.

**$RUN2$  (Pin 9):** Regulator 2 Enable. Forcing this pin to  $V_{IN}$  enables regulator 2, while forcing it to GND causes regulator 2 to shut down. This pin must be driven; do not float.

**$V_{FB2}$  (Pin 10):** Output Feedback. Receives the feedback voltage from the external resistive divider across the output. Nominal voltage for this pin is 0.6V.

**Exposed Pad (GND) (Pin 11):** Power Ground. Connect to the (-) terminal of  $C_{OUT}$ , and (-) terminal of  $C_{IN}$ . Must be connected to electrical ground on PCB.

## BLOCK DIAGRAM

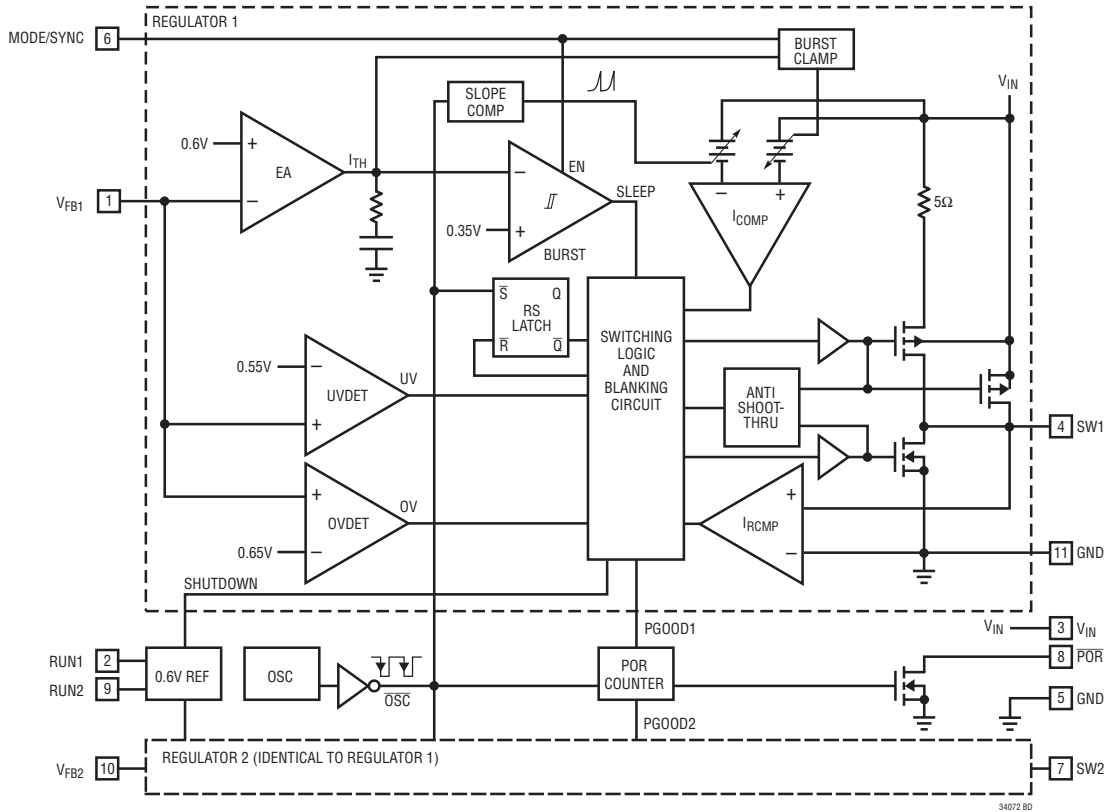

## OPERATION

The LTC3407-2 uses a constant-frequency, current mode architecture. The operating frequency is set at 2.25MHz and can be synchronized to an external oscillator. Both channels share the same clock and run in-phase. To suit a variety of applications, the selectable Mode pin allows the user to choose between low noise and high efficiency.

The output voltage is set by an external divider returned to the V<sub>FB</sub> pins. An error amplifier compares the divided output voltage with a reference voltage of 0.6V and adjusts the peak inductor current accordingly. Overvoltage and undervoltage comparators will pull the  $\overline{\text{POR}}$  output low if the output voltage is not within  $\pm 8.5\%$ . The  $\overline{\text{POR}}$  output will go high after 262,144 clock cycles (about 117ms) of achieving regulation.

### Main Control Loop

During normal operation, the top power switch (P-channel MOSFET) is turned on at the beginning of a clock cycle

when the V<sub>FB</sub> voltage is below the the reference voltage. The current into the inductor and the load increases until the current limit is reached. The switch turns off and energy stored in the inductor flows through the bottom switch (N-channel MOSFET) into the load until the next clock cycle.

The peak inductor current is controlled by the internally compensated I<sub>TH</sub> voltage, which is the output of the error amplifier. This amplifier compares the V<sub>FB</sub> pin to the 0.6V reference. When the load current increases, the V<sub>FB</sub> voltage decreases slightly below the reference. This decrease causes the error amplifier to increase the I<sub>TH</sub> voltage until the average inductor current matches the new load current.

The main control loop is shut down by pulling the RUN pin to ground.

## OPERATION

### Low Current Operation

Two modes are available to control the operation of the LTC3407-2 at low currents. Both modes automatically switch from continuous operation to the selected mode when the load current is low.

To optimize efficiency, the Burst Mode operation can be selected. When the load is relatively light, the LTC3407-2 automatically switches into Burst Mode operation, in which the PMOS switch operates intermittently based on load demand with a fixed peak inductor current. By running cycles periodically, the switching losses which are dominated by the gate charge losses of the power MOSFETs are minimized. The main control loop is interrupted when the output voltage reaches the desired regulated value. A hysteretic voltage comparator trips when  $I_{TH}$  is below 0.35V, shutting off the switch and reducing the power. The output capacitor and the inductor supply the power to the load until  $I_{TH}$  exceeds 0.65V, turning on the switch and the main control loop which starts another cycle.

For lower ripple noise at low currents, the pulse-skipping mode can be used. In this mode, the LTC3407-2 continues to switch at a constant frequency down to very low currents, where it will begin skipping pulses. The efficiency in

pulse-skipping mode can be improved slightly by connecting the SW node to the MODE/SYNC input which reduces the clock frequency by approximately 30%.

### Dropout Operation

When the input supply voltage decreases toward the output voltage, the duty cycle increases to 100% which is the dropout condition. In dropout, the PMOS switch is turned on continuously with the output voltage being equal to the input voltage minus the voltage drops across the internal P-channel MOSFET and the inductor.

An important design consideration is that the  $R_{DS(ON)}$  of the P-channel switch increases with decreasing input supply voltage (see Typical Performance Characteristics). Therefore, the user should calculate the power dissipation when the LTC3407-2 is used at 100% duty cycle with low input voltage (see Thermal Considerations in the Applications Information section).

### Low Supply Operation

To prevent unstable operation, the LTC3407-2 incorporates an undervoltage lockout circuit which shuts down the part when the input voltage drops below about 1.65V.

## APPLICATIONS INFORMATION

A general LTC3407-2 application circuit is shown in Figure 2. External component selection is driven by the load requirement, and begins with the selection of the inductor L. Once the inductor is chosen,  $C_{IN}$  and  $C_{OUT}$  can be selected.

### Inductor Selection

Although the inductor does not influence the operating frequency, the inductor value has a direct effect on ripple current. The inductor ripple current  $\Delta I_L$  decreases with higher inductance and increases with higher  $V_{IN}$  or  $V_{OUT}$ :

$$\Delta I_L = \frac{V_{OUT}}{f_0 \cdot L} \cdot \left(1 - \frac{V_{OUT}}{V_{IN}}\right)$$

Accepting larger values of  $\Delta I_L$  allows the use of low inductances, but results in higher output voltage ripple,

greater core losses, and lower output current capability. A reasonable starting point for setting ripple current is  $\Delta I_L = 0.4 \cdot I_{OUT(MAX)}$ , where  $I_{OUT(MAX)}$  is 800mA. The largest ripple current  $\Delta I_L$  occurs at the maximum input voltage. To guarantee that the ripple current stays below a specified maximum, the inductor value should be chosen according to the following equation:

$$L \geq \frac{V_{OUT}}{f_0 \cdot \Delta I_L} \cdot \left(1 - \frac{V_{OUT}}{V_{IN(MAX)}}\right)$$

The inductor value will also have an effect on Burst Mode operation. The transition from low current operation begins when the peak inductor current falls below a level set by the burst clamp. Lower inductor values result in higher ripple current which causes this to occur at lower load currents. This causes a dip in efficiency in the upper

## APPLICATIONS INFORMATION

range of low current operation. In Burst Mode operation, lower inductance values will cause the burst frequency to increase.

### Inductor Core Selection

Different core materials and shapes will change the size/current and price/current relationship of an inductor. Toroid or shielded pot cores in ferrite or permalloy materials are small and do not radiate much energy, but generally cost more than powdered iron core inductors with similar electrical characteristics. The choice of which style inductor to use often depends more on the price vs size requirements and any radiated field/EMI requirements than on what the LTC3407-2 requires to operate. Table 1 shows some typical surface mount inductors that work well in LTC3407-2 applications.

### Input Capacitor (C<sub>IN</sub>) Selection

In continuous mode, the input current of the converter is a square wave with a duty cycle of approximately  $V_{OUT}/V_{IN}$ . To prevent large voltage transients, a low equivalent series resistance (ESR) input capacitor sized for the maximum RMS current must be used. The maximum RMS capacitor current is given by:

$$I_{RMS} \approx I_{MAX} \frac{\sqrt{V_{OUT}(V_{IN} - V_{OUT})}}{V_{IN}}$$

where the maximum average output current  $I_{MAX}$  equals the peak current minus half the peak-to-peak ripple current,  $I_{MAX} = I_{LIM} - \Delta I_L/2$ .

This formula has a maximum at  $V_{IN} = 2V_{OUT}$ , where  $I_{RMS} = I_{OUT}/2$ . This simple worst-case is commonly used to design because even significant deviations do not offer much relief. Note that capacitor manufacturer's ripple current ratings are often based on only 2000 hours lifetime. This makes it advisable to further derate the capacitor, or choose a capacitor rated at a higher temperature than required. Several capacitors may also be paralleled to meet the size or height requirements of the design. An additional 0.1 $\mu$ F to 1 $\mu$ F ceramic capacitor is also recommended on  $V_{IN}$  for high frequency decoupling, when not using an all ceramic capacitor solution.

**Table 1. Representative Surface Mount Inductors**

PART NUMBER	VALUE ( $\mu$ H)	DCR ( $\Omega$ MAX)	MAX DC CURRENT (A)	SIZE W x L x H (mm <sup>3</sup> )
Sumida CDRH3D16	2.2	0.075	1.20	3.8 x 3.8 x 1.8
	3.3	0.110	1.10	
	4.7	0.162	0.90	
Sumida CDRH2D11	1.5	0.068	0.900	3.2 x 3.2 x 1.2
	2.2	0.170	0.780	
Sumida CMD4D11	2.2	0.116	0.950	4.4 x 5.8 x 1.2
	3.3	0.174	0.770	
Murata LQH32CN	1.0	0.060	1.00	2.5 x 3.2 x 2.0
	2.2	0.097	0.79	
Toko D312F	2.2	0.060	1.08	2.5 x 3.2 x 2.0
	3.3	0.260	0.92	
Panasonic ELT5KT	3.3	0.17	1.00	4.5 x 5.4 x 1.2
	4.7	0.20	0.95	

### Output Capacitor (C<sub>OUT</sub>) Selection

The selection of  $C_{OUT}$  is driven by the required ESR to minimize voltage ripple and load step transients. Typically, once the ESR requirement is satisfied, the capacitance is adequate for filtering. The output ripple ( $\Delta V_{OUT}$ ) is determined by:

$$\Delta V_{OUT} \approx \Delta I_L \left( ESR + \frac{1}{8f_0 C_{OUT}} \right)$$

where  $f$  = operating frequency,  $C_{OUT}$  = output capacitance and  $\Delta I_L$  = ripple current in the inductor. The output ripple is highest at maximum input voltage since  $\Delta I_L$  increases with input voltage. With  $\Delta I_L = 0.4 \cdot I_{OUT(MAX)}$ , the output ripple will be less than 100mV at maximum  $V_{IN}$  and  $f_0 = 2.25$ MHz with:

$$ESR_{C_{OUT}} < 150m\Omega$$

Once the ESR requirements for  $C_{OUT}$  have been met, the RMS current rating generally far exceeds the  $I_{RIPPLE(P-P)}$  requirement, except for an all ceramic solution.

In surface mount applications, multiple capacitors may have to be paralleled to meet the capacitance, ESR or RMS current handling requirement of the application. Aluminum electrolytic, special polymer, ceramic and dry tantalum capacitors are all available in surface mount packages. The OS-CON semiconductor dielectric capacitor available from Sanyo has the lowest ESR (size) product of any aluminum electrolytic at a somewhat higher price. Special polymer capacitors, such as Sanyo POSCAP, Panasonic Special Polymer (SP), and Kemet A700, of-

34072fc



## APPLICATIONS INFORMATION

Keeping the current small ( $<5\mu\text{A}$ ) in these resistors maximizes efficiency, but making them too small may allow stray capacitance to cause noise problems and reduce the phase margin of the error amp loop.

To improve the frequency response, a feedforward capacitor  $C_F$  may also be used. Great care should be taken to route the  $V_{FB}$  line away from noise sources, such as the inductor or the SW line.

### Power-On Reset

The  $\overline{\text{POR}}$  pin is an open-drain output which pulls low when either regulator is out of regulation. When both output voltages are within  $\pm 8.5\%$  of regulation, a timer is started which releases  $\overline{\text{POR}}$  after  $2^{18}$  clock cycles (about 117ms). This delay can be significantly longer in Burst Mode operation with low load currents, since the clock cycles only occur during a burst and there could be milliseconds of time between bursts. This can be bypassed by tying the  $\overline{\text{POR}}$  output to the MODE/SYNC input, to force pulse-skipping mode during a reset. In addition, if the output voltage faults during Burst Mode sleep,  $\overline{\text{POR}}$  could have a slight delay for an undervoltage output condition and may not respond to an overvoltage output. This can be avoided by using pulse-skipping mode instead. When either channel is shut down, the  $\overline{\text{POR}}$  output is pulled low, since one or both of the channels are not in regulation.

### Mode Selection and Frequency Synchronization

The MODE/SYNC pin is a multipurpose pin which provides mode selection and frequency synchronization. Connecting this pin to  $V_{IN}$  enables Burst Mode operation, which provides the best low current efficiency at the cost of a higher output voltage ripple. Connecting this pin to ground selects pulse-skipping mode, which provides the lowest output ripple, at the cost of low current efficiency.

The LTC3407-2 can also be synchronized to an external LTC3407-2 by the MODE/SYNC pin. During synchronization, the mode is set to pulse-skipping and the top switch turn-on is synchronized to the rising edge of the external clock.

### Checking Transient Response

The regulator loop response can be checked by looking at the load transient response. Switching regulators take

several cycles to respond to a step in load current. When a load step occurs,  $V_{OUT}$  immediately shifts by an amount equal to  $\Delta I_{LOAD} \cdot \text{ESR}$ , where ESR is the effective series resistance of  $C_{OUT}$ .  $\Delta I_{LOAD}$  also begins to charge or discharge  $C_{OUT}$ , generating a feedback error signal used by the regulator to return  $V_{OUT}$  to its steady-state value. During this recovery time,  $V_{OUT}$  can be monitored for overshoot or ringing that would indicate a stability problem.

The initial output voltage step may not be within the bandwidth of the feedback loop, so the standard second-order overshoot/DC ratio cannot be used to determine phase margin. In addition, a feedforward capacitor,  $C_F$ , can be added to improve the high frequency response, as shown in Figure 2. Capacitor  $C_F$  provides phase lead by creating a high frequency zero with R2, which improves the phase margin.

The output voltage settling behavior is related to the stability of the closed-loop system and will demonstrate the actual overall supply performance. For a detailed explanation of optimizing the compensation components, including a review of control loop theory, refer to Application Note 76.

In some applications, a more severe transient can be caused by switching in loads with large ( $>1\mu\text{F}$ ) input capacitors. The discharged input capacitors are effectively put in parallel with  $C_{OUT}$ , causing a rapid drop in  $V_{OUT}$ . No regulator can deliver enough current to prevent this problem, if the switch connecting the load has low resistance and is driven quickly. The solution is to limit the turn-on speed of the load switch driver. A Hot Swap™ controller is designed specifically for this purpose and usually incorporates current limiting, short-circuit protection, and soft-starting.

### Efficiency Considerations

The percent efficiency of a switching regulator is equal to the output power divided by the input power times 100%. It is often useful to analyze individual losses to determine what is limiting the efficiency and which change would produce the most improvement. Percent efficiency can be expressed as:

$$\% \text{Efficiency} = 100\% - (L1 + L2 + L3 + \dots)$$

where L1, L2, etc. are the individual losses as a percentage of input power.

Hot Swap is a trademark of Linear Technology Corporation.

34072fc

## APPLICATIONS INFORMATION

Although all dissipative elements in the circuit produce losses, four main sources usually account for most of the losses in LTC3407-2 circuits: 1)  $V_{IN}$  quiescent current, 2) switching losses, 3)  $I^2R$  losses, 4) other losses.

1. The  $V_{IN}$  current is the DC supply current given in the Electrical Characteristics which excludes MOSFET driver and control currents.  $V_{IN}$  current results in a small (<0.1%) loss that increases with  $V_{IN}$ , even at no load.
2. The switching current is the sum of the MOSFET driver and control currents. The MOSFET driver current results from switching the gate capacitance of the power MOSFETs. Each time a MOSFET gate is switched from low to high to low again, a packet of charge  $dQ$  moves from  $V_{IN}$  to ground. The resulting  $dQ/dt$  is a current out of  $V_{IN}$  that is typically much larger than the DC bias current. In continuous mode,  $I_{GATECHG} = f_0(Q_T + Q_B)$ , where  $Q_T$  and  $Q_B$  are the gate charges of the internal top and bottom MOSFET switches. The gate charge losses are proportional to  $V_{IN}$  and thus their effects will be more pronounced at higher supply voltages.
3.  $I^2R$  losses are calculated from the DC resistances of the internal switches,  $R_{SW}$ , and external inductor,  $R_L$ . In continuous mode, the average output current flows through inductor  $L$ , but is “chopped” between the internal top and bottom switches. Thus, the series resistance looking into the SW pin is a function of both top and bottom MOSFET  $R_{DS(ON)}$  and the duty cycle (DC):

$$R_{SW} = (R_{DS(ON)TOP})(DC) + (R_{DS(ON)BOT})(1 - DC)$$

The  $R_{DS(ON)}$  for both the top and bottom MOSFETs can be obtained from the Typical Performance Characteristics curves. Thus, to obtain  $I^2R$  losses:

$$I^2R \text{ losses} = (I_{OUT})^2(R_{SW} + R_L)$$

4. Other “hidden” losses such as copper trace and internal battery resistances can account for additional efficiency degradations in portable systems. It is very important to include these system-level losses in the design of a system. The internal battery and fuse resistance losses can be minimized by making sure that  $C_{IN}$  has adequate charge storage and very low ESR at the switching frequency. Other losses including diode conduction losses during dead-time and inductor core losses generally account for less than 2% total additional loss.

### Thermal Considerations

In a majority of applications, the LTC3407-2 does not dissipate much heat due to its high efficiency. However, in applications where the LTC3407-2 is running at high ambient temperature with low supply voltage and high duty cycles, such as in dropout, the heat dissipated may exceed the maximum junction temperature of the part. If the junction temperature reaches approximately 150°C, both power switches will turn off and the SW node will become high impedance.

To prevent the LTC3407-2 from exceeding the maximum junction temperature, the user will need to do some thermal analysis. The goal of the thermal analysis is to determine whether the power dissipated exceeds the maximum junction temperature of the part. The temperature rise is given by:

$$T_{RISE} = P_D \cdot \theta_{JA}$$

where  $P_D$  is the power dissipated by the regulator and  $\theta_{JA}$  is the thermal resistance from the junction of the die to the ambient temperature.

The junction temperature,  $T_J$ , is given by:

$$T_J = T_{RISE} + T_{AMBIENT}$$

As an example, consider the case when the LTC3407-2 is in dropout on both channels at an input voltage of 2.7V with a load current of 800mA and an ambient temperature of 70°C. From the Typical Performance Characteristics graph of Switch Resistance, the  $R_{DS(ON)}$  resistance of the main switch is 0.425Ω. Therefore, power dissipated by each channel is:

$$P_D = (I_{OUT})^2 \cdot R_{DS(ON)} = 272\text{mW}$$

The MS package junction-to-ambient thermal resistance,  $\theta_{JA}$ , is 45°C/W. Therefore, the junction temperature of the regulator operating in a 70°C ambient temperature is approximately:

$$T_J = 2 \cdot 0.272 \cdot 45 + 70 = 94.5^\circ\text{C}$$

which is below the absolute maximum junction temperature of 125°C.

## APPLICATIONS INFORMATION

### Design Example

As a design example, consider using the LTC3407-2 in an portable application with a Li-Ion battery. The battery provides a  $V_{IN} = 2.8V$  to  $4.2V$ . The load requires a maximum of  $800mA$  in active mode and  $2mA$  in standby mode. The output voltage is  $V_{OUT} = 2.5V$ . Since the load still needs power in standby, Burst Mode operation is selected for good low load efficiency.

First, calculate the inductor value for about 40%  $I_{OUT(MAX)}$  at maximum  $V_{IN}$ :

$$L \geq \frac{2.5V}{2.25MHz \cdot 320mA} \cdot \left(1 - \frac{2.5V}{4.2V}\right) = 1.4\mu H$$

Choosing a vendor's closest inductor value of  $2.2\mu H$ , results in a maximum ripple current of:

$$\Delta I_L = \frac{2.5V}{2.25MHz \cdot 2.2\mu H} \cdot \left(1 - \frac{2.5V}{4.2V}\right) = 204mA$$

For cost reasons, a ceramic capacitor will be used.  $C_{OUT}$  selection is then based on load step droop instead of ESR requirements. For a 5% output droop:

$$C_{OUT} \approx 2.5 \frac{800mA}{2.25MHz \cdot (5\% \cdot 2.5V)} = 7.1\mu F$$

A good standard value is  $10\mu F$ . Since the output impedance of a Li-Ion battery is very low,  $C_{IN}$  is typically  $10\mu F$ .

The output voltage can now be programmed by choosing the values of  $R1$  and  $R2$ . To maintain high efficiency, the current in these resistors should be kept small. Choosing  $2\mu A$  with the  $0.6V$  feedback voltage makes  $R1 \sim 300k$ . A close standard 1% resistor is  $280k$ , and  $R2$  is then  $887k$ .

The  $\overline{POR}$  pin is a common drain output and requires a pull-up resistor. A  $100k$  resistor is used for adequate speed.

Figure 1 shows the complete schematic for this design example.

### Board Layout Considerations

When laying out the printed circuit board, the following checklist should be used to ensure proper operation of the LTC3407-2. These items are also illustrated graphically

in the layout diagram of Figure 3. Check the following in your layout:

1. Does the capacitor  $C_{IN}$  connect to the power  $V_{IN}$  (Pin 3) and GND (Exposed Pad) as close as possible? This capacitor provides the AC current to the internal power MOSFETs and their drivers.
2. Are the  $C_{OUT}$  and  $L1$  closely connected? The (-) plate of  $C_{OUT}$  returns current to GND and the (-) plate of  $C_{IN}$ .
3. The resistor divider,  $R1$  and  $R2$ , must be connected between the (+) plate of  $C_{OUT}$  and a ground sense line terminated near GND (Exposed Pad). The feedback signals  $V_{FB}$  should be routed away from noisy components and traces, such as the SW line (Pins 4 and 7), and its trace should be minimized.
4. Keep sensitive components away from the SW pins. The input capacitor  $C_{IN}$  and the resistors  $R1$  to  $R4$  should be routed away from the SW traces and the inductors.
5. A ground plane is preferred, but if not available, keep the signal and power grounds segregated with small signal components returning to the GND pin at one point and should not share the high current path of  $C_{IN}$  or  $C_{OUT}$ .
6. Flood all unused areas on all layers with copper. Flooding with copper will reduce the temperature rise of power components. These copper areas should be connected to  $V_{IN}$  or GND.

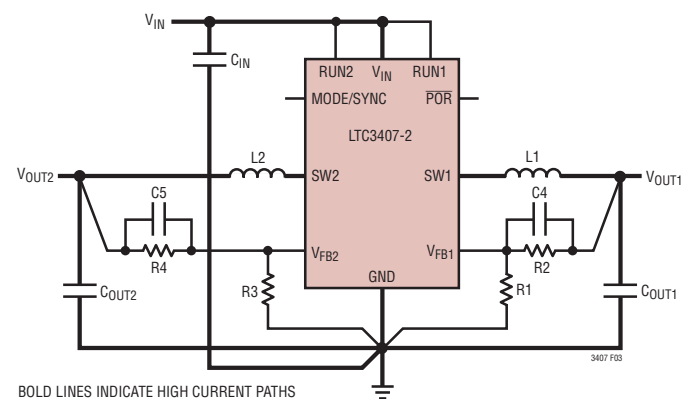
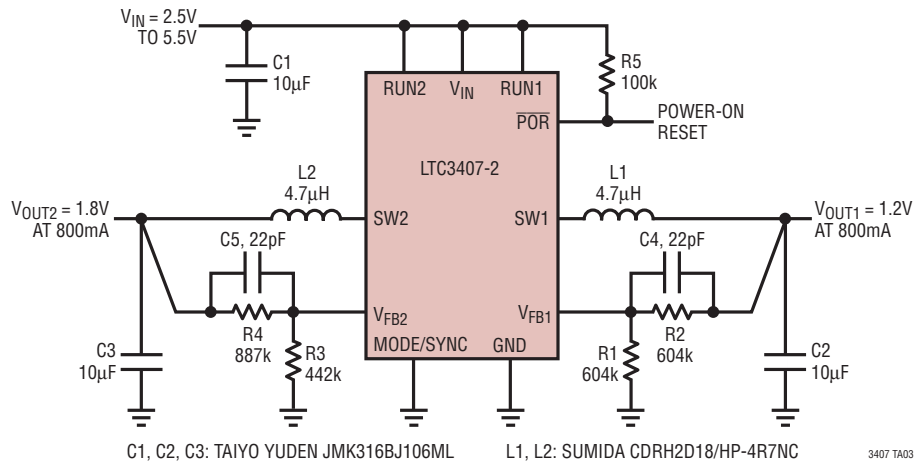

Figure 3. LTC3407-2 Layout Diagram (See Board Layout Checklist)

# TYPICAL APPLICATIONS

## Low Ripple Buck Regulators Using Ceramic Capacitors



Efficiency vs Load Current

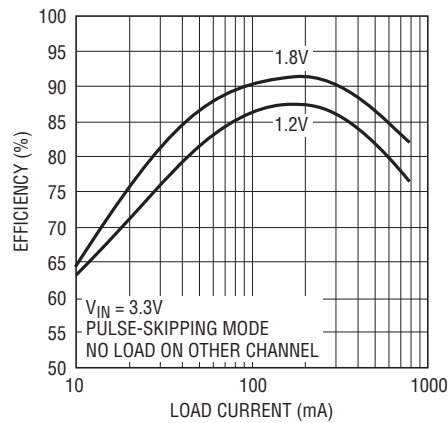

## TYPICAL APPLICATIONS

### 1.2mm Height Core Supply

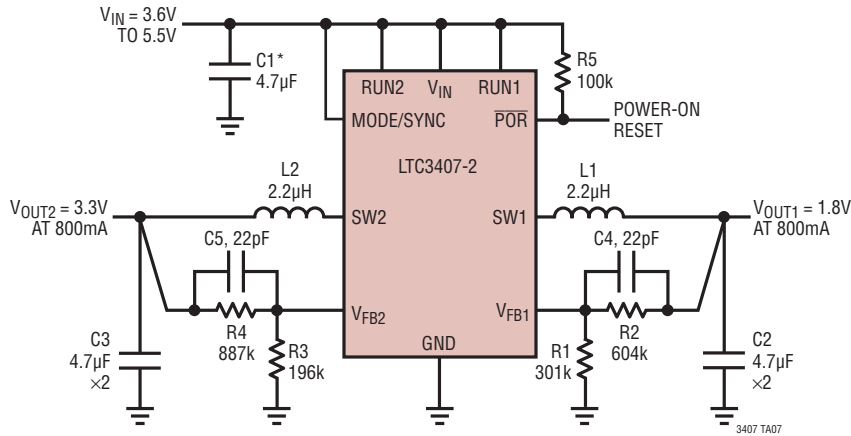

C1, C2, C3: TDK C1608X5R0J475M  
 L1, L2: CMD4D11-2R2  
 \*IF C1 IS GREATER THAN 3" FROM POWER SOURCE,  
 ADDITIONAL CAPACITANCE MAY BE REQUIRED.

### Efficiency vs Load Current

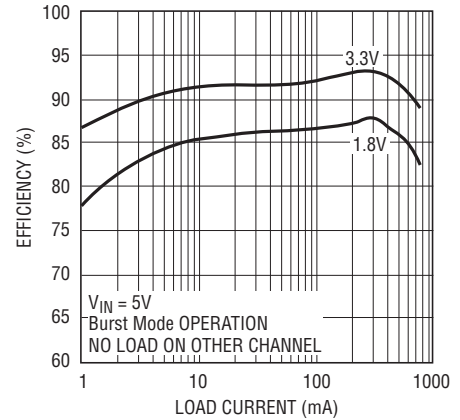

3407 TA08

## PACKAGE DESCRIPTION

**DD Package**  
**10-Lead Plastic DFN (3mm × 3mm)**  
 (Reference LTC DWG # 05-08-1699 Rev B)

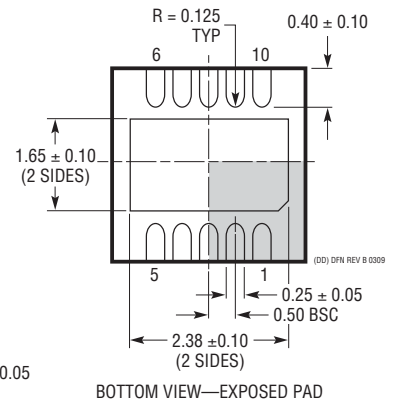
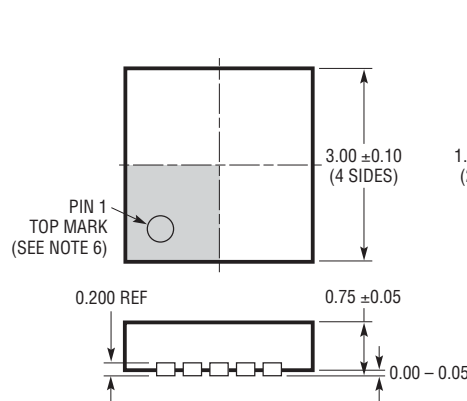
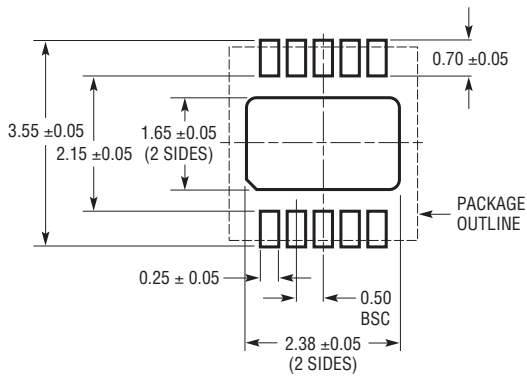

### RECOMMENDED SOLDER PAD PITCH AND DIMENSIONS

#### NOTE:

- DRAWING TO BE MADE A JEDEC PACKAGE OUTLINE M0-229 VARIATION OF (WEED-2). CHECK THE LTC WEBSITE DATA SHEET FOR CURRENT STATUS OF VARIATION ASSIGNMENT
- DRAWING NOT TO SCALE
- ALL DIMENSIONS ARE IN MILLIMETERS
- DIMENSIONS OF EXPOSED PAD ON BOTTOM OF PACKAGE DO NOT INCLUDE MOLD FLASH. MOLD FLASH, IF PRESENT, SHALL NOT EXCEED 0.15mm ON ANY SIDE
- EXPOSED PAD SHALL BE SOLDER PLATED
- SHADED AREA IS ONLY A REFERENCE FOR PIN 1 LOCATION ON THE TOP AND BOTTOM OF PACKAGE

# PACKAGE DESCRIPTION

## MSE Package 10-Lead Plastic MSOP, Exposed Die Pad (Reference LTC DWG # 05-08-1664 Rev C)

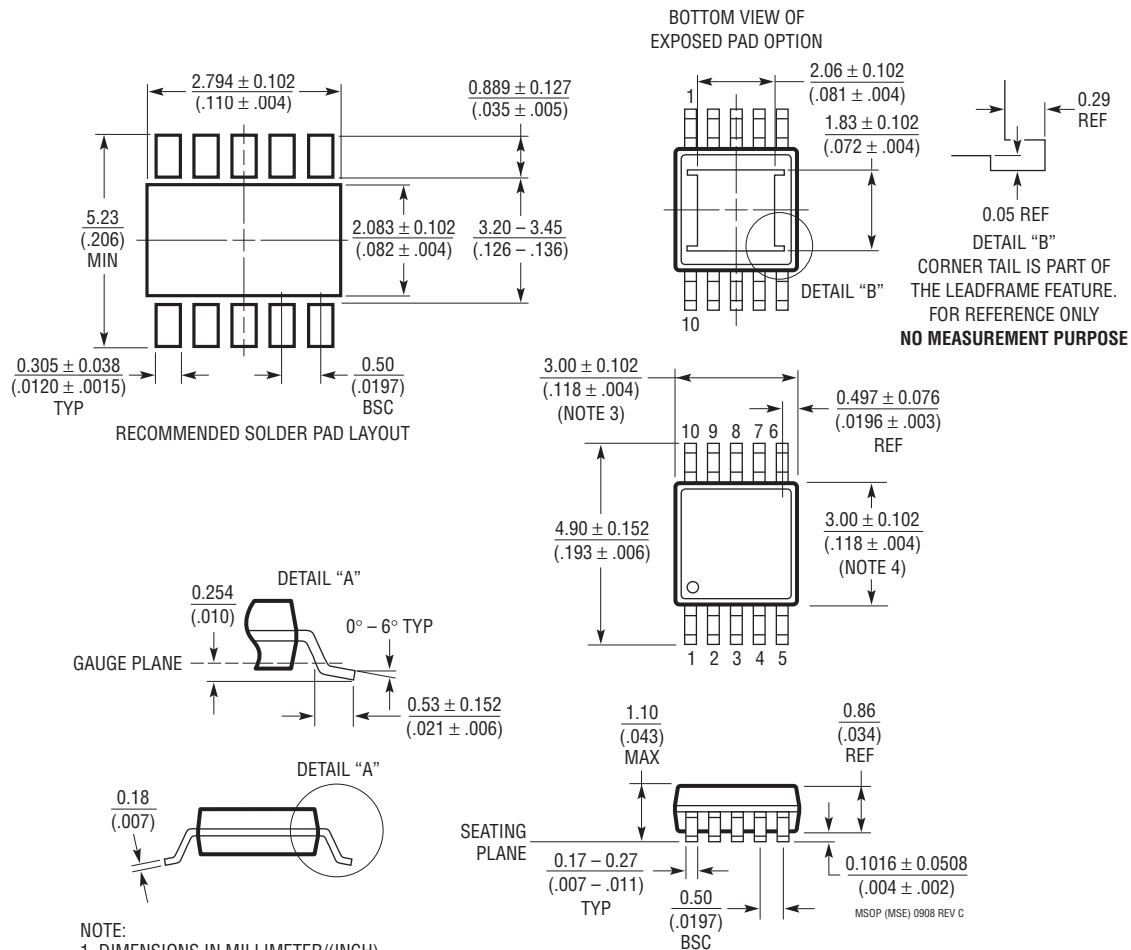

- NOTE:
1. DIMENSIONS IN MILLIMETER/(INCH)
  2. DRAWING NOT TO SCALE
  3. DIMENSION DOES NOT INCLUDE MOLD FLASH, PROTRUSIONS OR GATE BURRS.  
MOLD FLASH, PROTRUSIONS OR GATE BURRS SHALL NOT EXCEED 0.152mm (.006") PER SIDE
  4. DIMENSION DOES NOT INCLUDE INTERLEAD FLASH OR PROTRUSIONS.  
INTERLEAD FLASH OR PROTRUSIONS SHALL NOT EXCEED 0.152mm (.006") PER SIDE
  5. LEAD COPLANARITY (BOTTOM OF LEADS AFTER FORMING) SHALL BE 0.102mm (.004") MAX

## TYPICAL APPLICATION

### 2mm Height Lithium-Ion Single Inductor Buck-Boost Regulator and a Buck Regulator

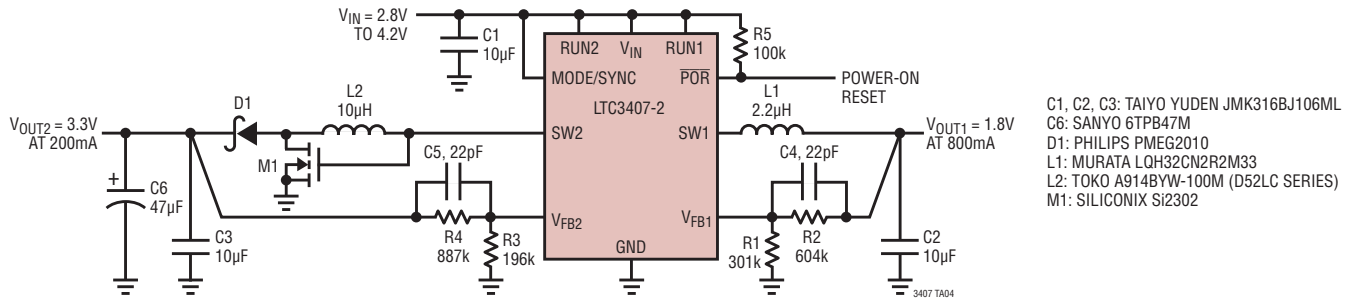

**Efficiency vs Load Current**

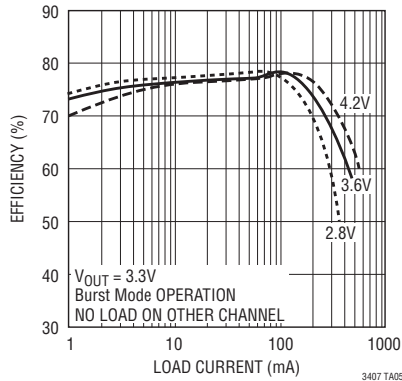

**Efficiency vs Load Current**

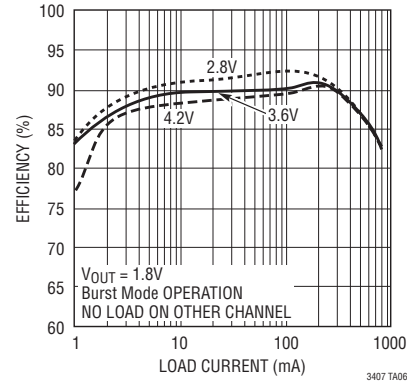

## RELATED PARTS

PART NUMBER	DESCRIPTION	COMMENTS
LTC1878	600mA ( $I_{OUT}$ ), 550kHz, Synchronous Step-Down DC/DC Converter	95% Efficiency, $V_{IN}$ : 2.7V to 6V, $V_{OUT(MIN)} = 0.8V$ , $I_Q = 10\mu A$ , $I_{SD} < 1\mu A$ , MSOP-8, Package
LT1940	Dual Output 1.4A ( $I_{OUT}$ ), Constant 1.1MHz, High Efficiency Step-Down DC/DC Converter	$V_{IN}$ : 3V to 25V, $V_{OUT(MIN)} = 1.2V$ , $I_Q = 2.5mA$ , $I_{SD} < 1\mu A$ , TSSOP-16E Package
LTC3252	Dual 250mA ( $I_{OUT}$ ), 1MHz, Spread Spectrum Inductorless Step-Down DC/DC Converter	88% Efficiency, $V_{IN}$ : 2.7V to 5.5V, $V_{OUT(MIN)} = 0.9V$ to 1.6V, $I_Q = 60\mu A$ , $I_{SD} < 1\mu A$ , DFN-12 Package
LTC3405/ LTC3405A	300mA ( $I_{OUT}$ ), 1.5MHz, Synchronous Step-Down DC/DC Converters	96% Efficiency, $V_{IN}$ : 2.5V to 5.5V, $V_{OUT(MIN)} = 0.8V$ , $I_Q = 20\mu A$ , $I_{SD} < 1\mu A$ , ThinSOT™ Package
LTC3406/ LTC3406B	600mA ( $I_{OUT}$ ), 1.5MHz, Synchronous Step-Down DC/DC Converters	96% Efficiency, $V_{IN}$ : 2.5V to 5.5V, $V_{OUT(MIN)} = 0.6V$ , $I_Q = 20\mu A$ , $I_{SD} < 1\mu A$ , ThinSOT Package
LT3407	600mA, 1.5MHz Dual Synchronous Step-Down DC/DC Converter	96% Efficiency, $V_{IN}$ : 2.5V to 5.5V, $V_{OUT(MIN)} = 0.6V$ , $I_Q = 40\mu A$ , $I_{SD} < 1\mu A$ , MSE, DFN Package
LTC3411	1.25A ( $I_{OUT}$ ), 4MHz, Synchronous Step Down DC/DC Converter	95% Efficiency, $V_{IN}$ : 2.5V to 5.5V, $V_{OUT(MIN)} = 0.8V$ , $I_Q = 60\mu A$ , $I_{SD} < 1\mu A$ , MSOP-10 Package
LTC3412	2.5A ( $I_{OUT}$ ), 4MHz, Synchronous Step Down DC/DC Converter	95% Efficiency, $V_{IN}$ : 2.5V to 5.5V, $V_{OUT(MIN)} = 0.8V$ , $I_Q = 60\mu A$ , $I_{SD} < 1\mu A$ , TSSOP-16E Package
LTC3414	4A ( $I_{OUT}$ ), 4MHz, Synchronous Step Down DC/DC Converter	95% Efficiency, $V_{IN}$ : 2.25V to 5.5V, $V_{OUT(MIN)} = 0.8V$ , $I_Q = 64\mu A$ , $I_{SD} < 1\mu A$ , TSSOP-28E Package
LTC3440	600mA ( $I_{OUT}$ ), 2MHz, Synchronous Buck-Boost DC/DC Converter	95% Efficiency, $V_{IN}$ : 2.5V to 5.5V, $V_{OUT(MIN)} = 2.5V$ , $I_Q = 25\mu A$ , $I_{SD} < 1\mu A$ , MSOP-10 Package

ThinSOT is a trademark of Linear Technology Corporation.

34072fc