

Dual 2-Phase, No R_{SENSE}^{TM} , Synchronous Controller with Spread Spectrum

FEATURES

- Spread Spectrum Operation
- Tracking Function
- No Current Sense Resistors Required
- Out-of-Phase Controllers Reduce Required Input Capacitance
- Wide V_{IN} Range: 2.75V to 9.8V
- Current Mode Operation
- $0.6V \pm 1.5\%$ Voltage Reference
- Low Dropout Operation: 100% Duty Cycle
- Pulse Skipping Operation at Light Loads
- Internal Soft-Start Circuitry
- Power Good Output Voltage Monitor
- Output Overvoltage Protection
- Micropower Shutdown: $I_Q = 9\mu A$
- Tiny Low Profile (4mm × 4mm) QFN and Narrow SSOP Packages

APPLICATIONS

- One or Two Lithium-Ion Powered Devices
- Notebook and Palmtop Computers, PDAs
- Portable Instruments
- Distributed DC Power Systems

LT, LTC and LT are registered trademarks of Linear Technology Corporation. No R_{SENSE} is a trademark of Linear Technology Corporation.

Protected by U.S. Patents including 5481178, 5929620, 6144194, 6580258, 6304066, 6611131, 6498466.

DESCRIPTION

The LTC[®]3736-1 is a 2-phase dual synchronous step-down switching regulator controller with tracking that drives external complementary power MOSFETs using few external components. The constant frequency current mode architecture with MOSFET V_{DS} sensing eliminates the need for sense resistors and improves efficiency. Power loss and noise due to the ESR of the input capacitance are minimized by operating the two controllers out of phase.

A unique spread spectrum architecture randomly varies the LTC3736-1's switching frequency from 450kHz to 580kHz, significantly reducing the peak radiated and conducted noise on both the input and output supplies, making it easier to comply with electromagnetic interference (EMI) standards.

Pulse skipping operation provides high efficiency at light loads. 100% duty cycle capability provides low dropout operation, extending operating time in battery-powered systems. The high switching frequencies allow for the use of small surface mount inductors and capacitors.

The LTC3736-1 is available in the low profile (0.75mm) 24-pin thermally enhanced (4mm × 4mm) QFN package and 24-lead narrow SSOP packages.

TYPICAL APPLICATION

Low Noise, 2-Phase, Dual Synchronous DC/DC Step-Down Converter

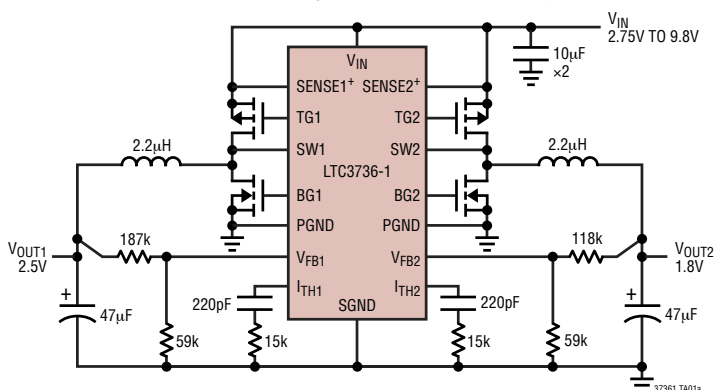

Output Voltage Frequency Spectrum

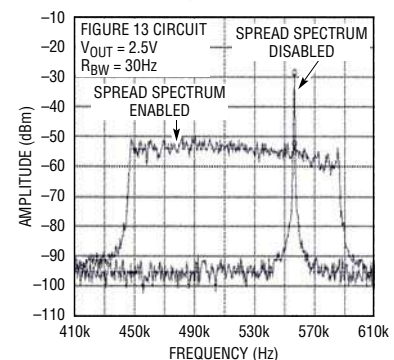

37361 TA01b

37361f

LTC3736-1

ABSOLUTE MAXIMUM RATINGS (Note 1)

| | | | |
|---------------------------------------------------------------------------|----------------------------------------|-------------------------------------------------------------------|----------------|
| Input Supply Voltage (V_{IN}) | -0.3V to 10V | TG1, TG2, BG1, BG2 Peak Output Current ($<10\mu\text{s}$) | 1A |
| FREQ, RUN/SS, SSDIS, TRACK, SENSE1+, SENSE2+, IPRG1, IPRG2 Voltages | -0.3V to ($V_{IN} + 0.3\text{V}$) | Operating Temperature Range (Note 2) ... | -40°C to 85°C |
| V_{FB1} , V_{FB2} , I_{TH1} , I_{TH2} Voltages | -0.3V to 2.4V | Storage Temperature Range | -65°C to 125°C |
| SW1, SW2 Voltages | -2V to $V_{IN} + 1\text{V}$ or 10V Max | Junction Temperature (Note 3) | 125°C |
| PGOOD | -0.3V to 10V | Lead Temperature (Soldering, 10 sec) (LTC3736EGN-1) | 300°C |

PACKAGE/ORDER INFORMATION

| | | | |
|------------------------------------------------------------------------------------------------------------------------------------------------------------------------------------------------------------------------|-------------------|-------------------------------------------------------------------------------------------------------------------------------------------------|-------------------|
| <p>UF PACKAGE 24-LEAD (4mm × 4mm) PLASTIC QFN</p> <p>$T_{JMAX} = 125^{\circ}\text{C}$, $\theta_{JA} = 37^{\circ}\text{C/W}$ EXPOSED PAD (PIN 25) IS PGND MUST BE SOLDERED TO PCB</p> | ORDER PART NUMBER | <p>GN PACKAGE 24-LEAD PLASTIC SSOP</p> <p>$T_{JMAX} = 125^{\circ}\text{C}$, $\theta_{JA} = 130^{\circ}\text{C/W}$</p> | ORDER PART NUMBER |
| | LTC3736EUF-1 | | LTC3736EGN-1 |
| | UF PART MARKING | | |
| | 3736-1 | | |

Consult LTC Marketing for parts specified with wider operating temperature ranges.

ELECTRICAL CHARACTERISTICS

The ● denotes specifications that apply over the full operating temperature range, otherwise specifications are at $T_A = 25^{\circ}\text{C}$. $V_{IN} = 4.2\text{V}$ unless otherwise specified.

| PARAMETER | CONDITIONS | MIN | TYP | MAX | UNITS |
|--------------------------------|------------------------------------------------|---------|------|-------|---------------|
| Main Control Loops | | | | | |
| Input DC Supply Current | (Note 4) | | | | |
| Normal Mode | | | 500 | 850 | μA |
| Shutdown | RUN/SS = 0V | | 9 | 20 | μA |
| UVLO | $V_{IN} < \text{UVLO Threshold}$ | | 3 | 10 | μA |
| Undervoltage Lockout Threshold | V_{IN} Falling | ● 1.95 | 2.25 | 2.55 | V |
| | V_{IN} Rising | ● 2.15 | 2.45 | 2.75 | V |
| Shutdown Threshold at RUN/SS | | 0.45 | 0.65 | 0.85 | V |
| Start-Up Current Source | RUN/SS = 0V | 0.5 | 0.7 | 1 | μA |
| Regulated Feedback Voltage | 0°C to 85°C (Note 5) | 0.591 | 0.6 | 0.609 | V |
| | -40°C to 85°C | ● 0.588 | 0.6 | 0.612 | V |
| Output Voltage Line Regulation | $2.75\text{V} < V_{IN} < 9.8\text{V}$ (Note 5) | | 0.05 | 0.2 | mV/V |

37361f

ELECTRICAL CHARACTERISTICS

The ● denotes specifications that apply over the full operating temperature range, otherwise specifications are at $T_A = 25^\circ\text{C}$. $V_{IN} = 4.2\text{V}$ unless otherwise specified.

| PARAMETER | CONDITIONS | MIN | TYP | MAX | UNITS | |
|---------------------------------------------------------------------------------------|------------------------------------------------|------|-------|-------|-------|-----|
| Output Voltage Load Regulation | $I_{TH} = 0.9\text{V}$ (Note 5) | | 0.12 | 0.5 | % | |
| | $I_{TH} = 1.7\text{V}$ | | -0.12 | -0.5 | % | |
| $V_{FB1,2}$ Input Current | (Note 5) | | 10 | 50 | nA | |
| TRACK Input Current | TRACK = 0.6V | | 10 | 50 | nA | |
| Overshoot Protection Threshold | Measured at V_{FB} | 0.66 | 0.68 | 0.7 | V | |
| Overshoot Protection Hysteresis | | | 20 | | mV | |
| Top Gate (TG) Drive 1, 2 Rise Time | $C_L = 3000\text{pF}$ | | 40 | | ns | |
| Top Gate (TG) Drive 1, 2 Fall Time | $C_L = 3000\text{pF}$ | | 40 | | ns | |
| Bottom Gate (BG) Drive 1, 2 Rise Time | $C_L = 3000\text{pF}$ | | 50 | | ns | |
| Bottom Gate (BG) Drive 1, 2 Fall Time | $C_L = 3000\text{pF}$ | | 40 | | ns | |
| Maximum Current Sense Voltage (SENSE ⁺ – SW)($\Delta V_{SENSE(MAX)}$) | IPRG = Floating (Note 6) | ● | 110 | 125 | 140 | mV |
| | IPRG = 0V | ● | 70 | 85 | 100 | mV |
| | IPRG = V_{IN} | ● | 185 | 204 | 223 | mV |
| Soft-Start Time | Time for V_{FB1} to Ramp from 0.05V to 0.55V | | 0.667 | 0.833 | 1 | ms |
| Spread Spectrum Oscillator | | | | | | |
| Oscillator Frequency | Spread Spectrum Disabled (SSDIS = V_{IN}) | | | | | |
| | $V_{FREQ} = \text{Floating}$ | ● | 480 | 550 | 600 | kHz |
| | $V_{FREQ} = 0\text{V}$ | ● | 260 | 300 | 340 | kHz |
| | $V_{FREQ} = V_{IN}$ | ● | 650 | 750 | 825 | kHz |
| Spread Spectrum Frequency Range | SSDIS = GND | | | | | |
| | Minimum Switching Frequency | | | 450 | kHz | |
| | Maximum Switching Frequency | | | 580 | kHz | |
| PGOOD Output | | | | | | |
| PGOOD Voltage Low | I_{PGOOD} Sinking 1mA | | 125 | | mV | |
| PGOOD Trip Level | V_{FB} with Respect to Set Output Voltage | | | | | |
| | $V_{FB} < 0.6\text{V}$, Ramping Positive | | -13 | -10.0 | -7 | % |
| | $V_{FB} < 0.6\text{V}$, Ramping Negative | | -16 | -13.3 | -10 | % |
| | $V_{FB} > 0.6\text{V}$, Ramping Negative | | 7 | 10.0 | 13 | % |
| | $V_{FB} > 0.6\text{V}$, Ramping Positive | | 10 | 13.3 | 16 | % |

Note 1: Absolute Maximum Ratings are those values beyond which the life of a device may be impaired.

Note 2: The LTC3736E-1 is guaranteed to meet specified performance from 0°C to 70°C . Specifications over the -40°C to 85°C operating range are assured by design, characterization and correlation with statistical process controls.

Note 3: T_J is calculated from the ambient temperature T_A and power dissipation P_D according to the following formula:

$$T_J = T_A + (P_D \cdot \theta_{JA})^\circ\text{C/W}$$

Note 4: Dynamic supply current is higher due to gate charge being delivered at the switching frequency.

Note 5: The LTC3736-1 is tested in a feedback loop that serves I_{TH} to a specified voltage and measures the resultant V_{FB} voltage.

Note 6: Peak current sense voltage is reduced dependent on duty cycle to a percentage of value as shown in Figure 2.

TYPICAL PERFORMANCE CHARACTERISTICS $T_A = 25^\circ\text{C}$ unless otherwise noted.

Efficiency and Power Lost vs Load Current

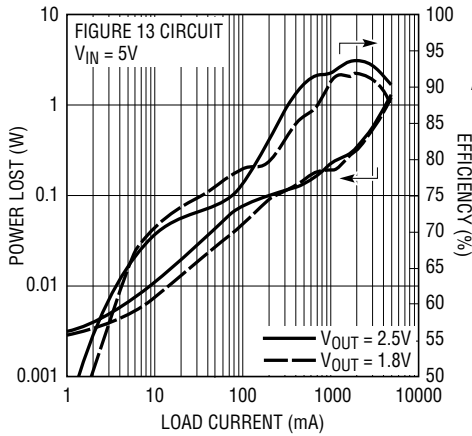

37361 G01

Load Step (Spread Spectrum Enabled)

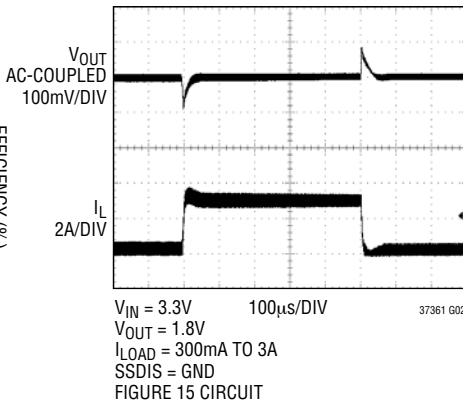

37361 G02

Load Step (Spread Spectrum Disabled)

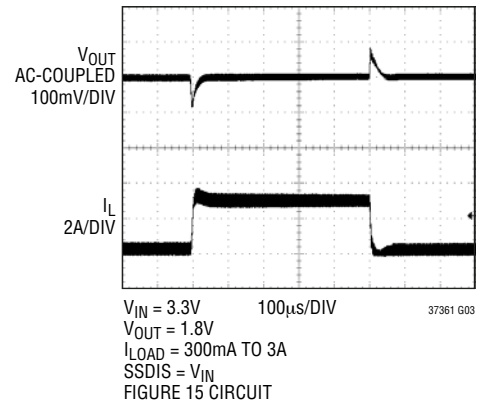

37361 G03

Input Voltage Noise (Spread Spectrum Disabled)

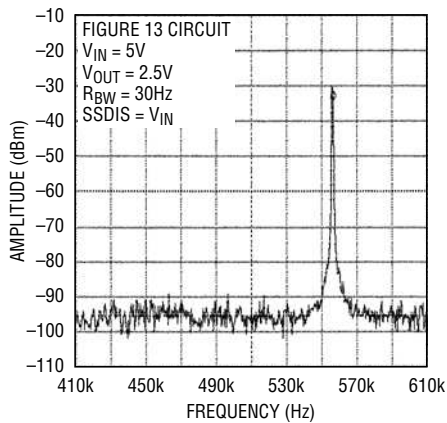

37361 G04

Input Voltage Noise (Spread Spectrum Enabled)

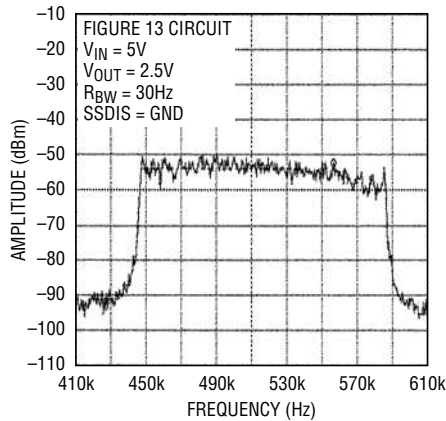

37361 G05

Tracking Start-Up with Internal Soft-Start ($C_{SS} = 0\mu\text{F}$)

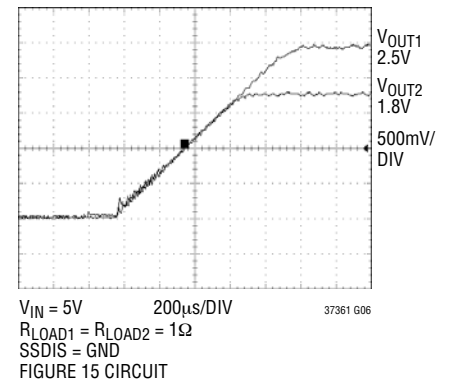

37361 G06

Tracking Start-Up with External Soft-Start ($C_{SS} = 0.15\mu\text{F}$)

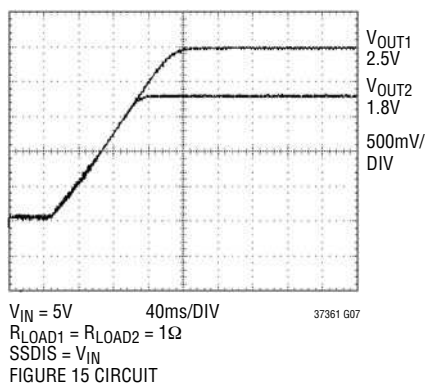

37361 G07

Output Voltage Ripple

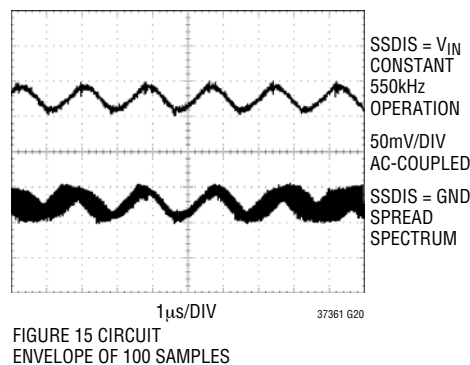

37361 G20

Oscillator Frequency vs Input Voltage

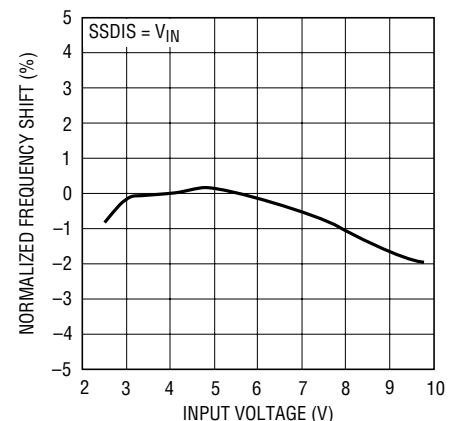

37361 G08

TYPICAL PERFORMANCE CHARACTERISTICS $T_A = 25^\circ\text{C}$ unless otherwise noted.

Maximum Current Sense Voltage vs I_{TH} Pin Voltage

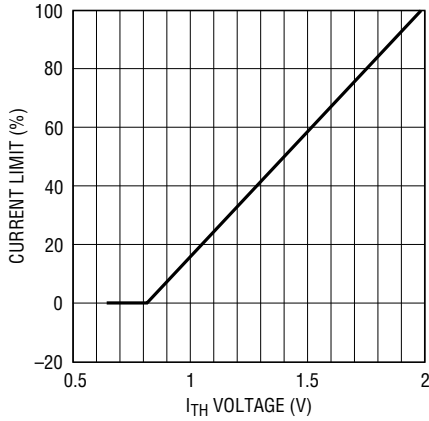

37361 G09

Efficiency and Power Lost vs Load Current

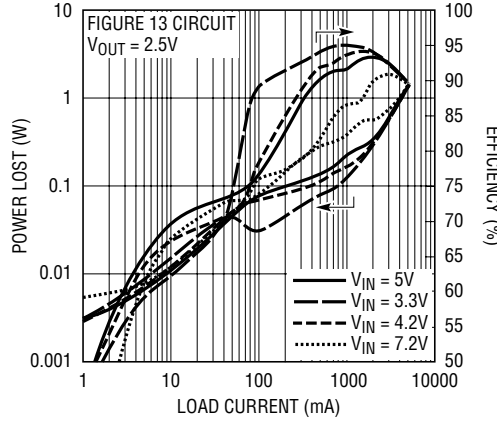

37361 G10

Efficiency vs Load Current

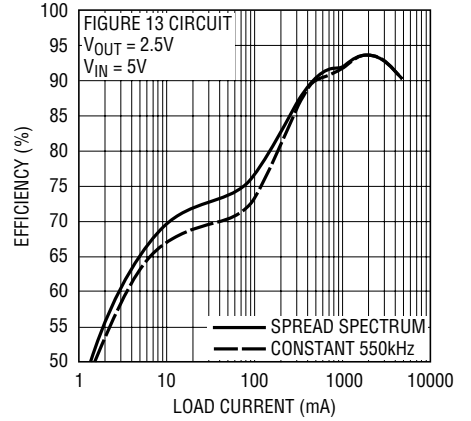

37361 G19

Regulated Feedback Voltage vs Temperature

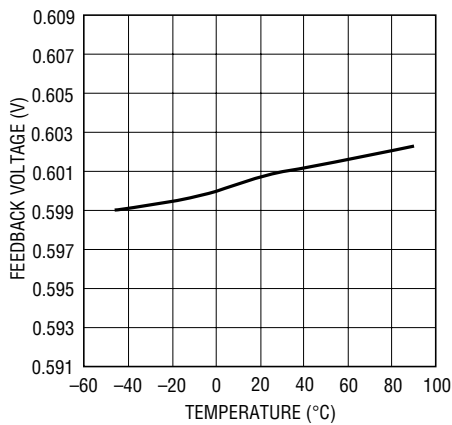

37361 G11

Shutdown (RUN) Threshold vs Temperature

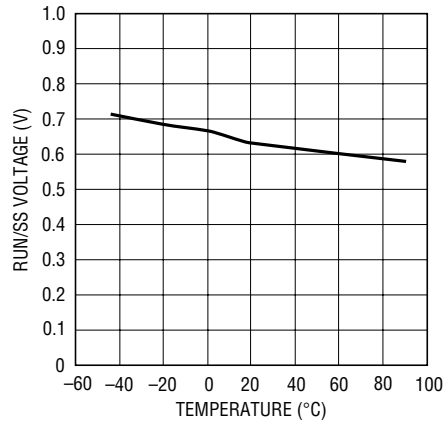

37361 G12

RUN/SS Pull-Up Current vs Temperature

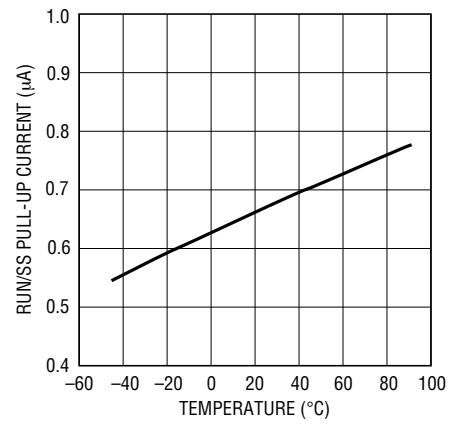

37361 G13

Maximum Current Sense Threshold vs Temperature

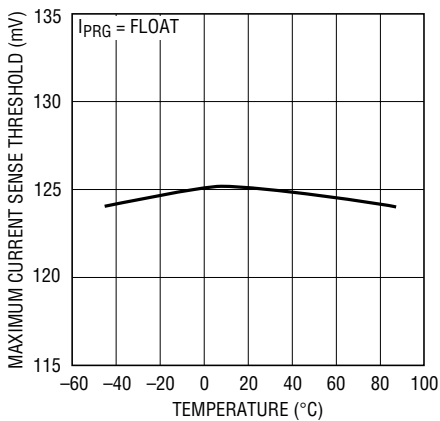

37361 G14

Oscillator Frequency vs Temperature

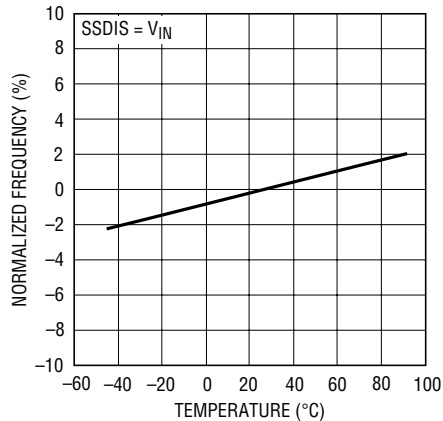

37361 G15

Undervoltage Lockout Threshold vs Temperature

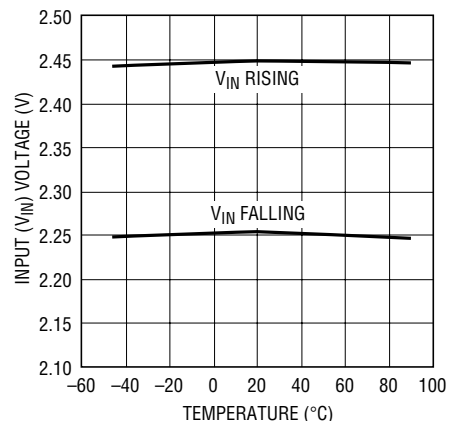

37361 G16

TYPICAL PERFORMANCE CHARACTERISTICS $T_A = 25^\circ\text{C}$ unless otherwise noted.

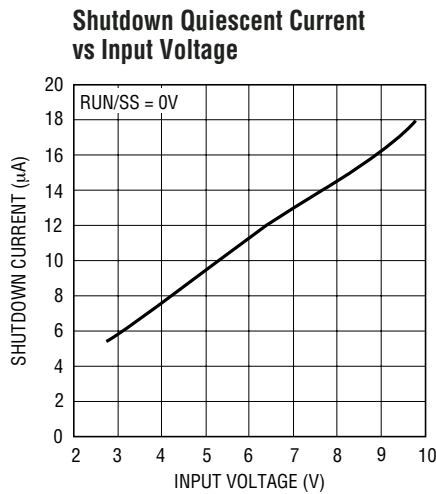

37361 G17

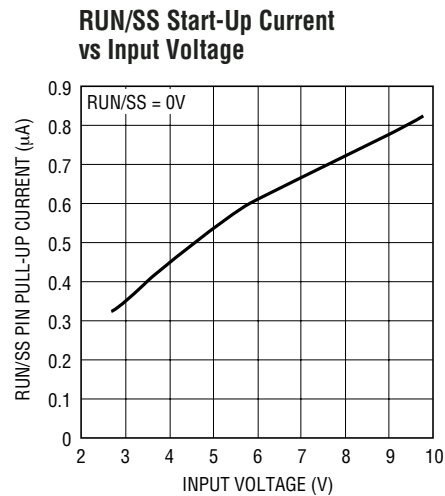

37361 G18

PIN FUNCTIONS (UF/GN Package)

I_{TH1}/I_{TH2} (Pins 1, 8/Pins 4, 11): Current Threshold and Error Amplifier Compensation Point. Nominal operating range on these pins is from 0.7V to 2V. The voltage on these pins determines the threshold of the main current comparator.

FREQ (Pin 3/Pin 6): Frequency Filter and Adjust Pin. Normally, when spread spectrum operation is enabled (SSDIS = GND), a capacitor (1nF to 4.7nF) is connected from this pin to SGND or V_{IN} to filter and smooth the changes in frequency of the LTC3736-1's internal oscillator.

When spread spectrum operation is disabled (SSDIS = V_{IN}), this pin serves as a frequency adjust pin. In this mode, tying this pin to GND selects 300kHz operation; tying this pin to V_{IN} selects 750kHz operation; floating this pin selects 550kHz operation.

When spread spectrum operation is enabled (SSDIS = GND), an external voltage between approximately 0.7V and 1.5V may be applied to this pin to adjust (in an analog manner) the LTC3736-1's frequency.

SGND (Pin 4/Pin 7): Small-Signal Ground. This pin serves as the ground connection for most internal circuits.

V_{IN} (Pin 5/Pin 8): Chip Signal Power Supply. This pin powers the entire chip except for the gate drivers. Externally filtering this pin with a lowpass RC network (e.g.,

$R = 10\Omega$, $C = 1\mu\text{F}$) is suggested to minimize noise pickup, especially in high load current applications.

TRACK (Pin 6/Pin 9): Tracking Input for Second Controller. Allows the start-up of V_{OUT2} to "track" that of V_{OUT1} according to a ratio established by a resistor divider on V_{OUT1} connected to the TRACK pin. For one-to-one tracking of V_{OUT1} and V_{OUT2} during start-up, a resistor divider with a ratio equal to those connected to V_{FB2} from V_{OUT2} should be used to connect to TRACK from V_{OUT1} .

PGOOD (Pin 9/Pin 12): Power Good Output Voltage Monitor Open-Drain Logic Output. This pin is pulled to ground when the voltage on either feedback pin (V_{FB1} , V_{FB2}) is not within $\pm 13.3\%$ of its nominal set point.

PGND (Pins 12, 16, 20, 25/Pins 15, 19, 23): Power Ground. These pins serve as the ground connection for the gate drivers and the negative input to the reverse current comparators. The Exposed Pad (UF package) must be soldered to PCB ground.

RUN/SS (Pin 14/Pin 17): Run Control Input and Optional External Soft-Start Input. Forcing this pin below 0.65V shuts down the chip (both channels). Driving this pin to V_{IN} or releasing this pin enables the chip, using the chip's internal soft-start. An external soft-start can be programmed by connecting a capacitor between this pin and ground.

PIN FUNCTIONS (UF/GN Package)

TG1/TG2 (Pins 17, 15/Pins 20, 18): Top (PMOS) Gate Drive Output. These pins drive the gates of the external P-channel MOSFETs. These pins have an output swing from PGND to SENSE⁺.

SSDIS (Pin 18/Pin 21): Spread Spectrum Disable Input. Tie this pin to V_{IN} to disable spread spectrum operation. In this mode, the LTC3736-1 operates at a constant frequency determined by the voltage on the FREQ pin. Tie this pin to GND to enable spread spectrum operation.

BG1/BG2 (Pins 19, 13/Pins 22, 16): Bottom (NMOS) Gate Drive Output. These pins drive the gates of the external N-channel MOSFETs. These pins have an output swing from PGND to SENSE⁺.

SENSE1⁺/SENSE2⁺ (Pins 21, 11/Pins 24, 14): Positive Input to Differential Current Comparator. Also powers the gate drivers. Normally connected to the source of the external P-channel MOSFET.

SW1/SW2 (Pins 22, 10/Pins 1, 13): Switch Node Connection to Inductor. Also the negative input to differential peak current comparator and an input to the reverse current comparator. Normally connected to the drain of the external P-channel MOSFETs, the drain of the external N-channel MOSFET and the inductor.

IPRG1/IPRG2 (Pins 23, 2/Pins 2, 5): Three-State Pins to Select Maximum Peak Sense Voltage Threshold. These pins select the maximum allowed voltage drop between the SENSE⁺ and SW pins (i.e., the maximum allowed drop across the external P-channel MOSFET) for each channel. Tie to V_{IN}, GND or float to select 204mV, 85mV or 125mV respectively.

V_{FB1}/V_{FB2} (Pins 24, 7/Pins 3, 10): Feedback Pins. Receives the remotely sensed feedback voltage for its controller from an external resistor divider across the output.

Exposed Pad (Pin 25/NA): The exposed pad (UF Package) must be soldered to the PCB ground.

FUNCTIONAL DIAGRAM (Common Circuitry)

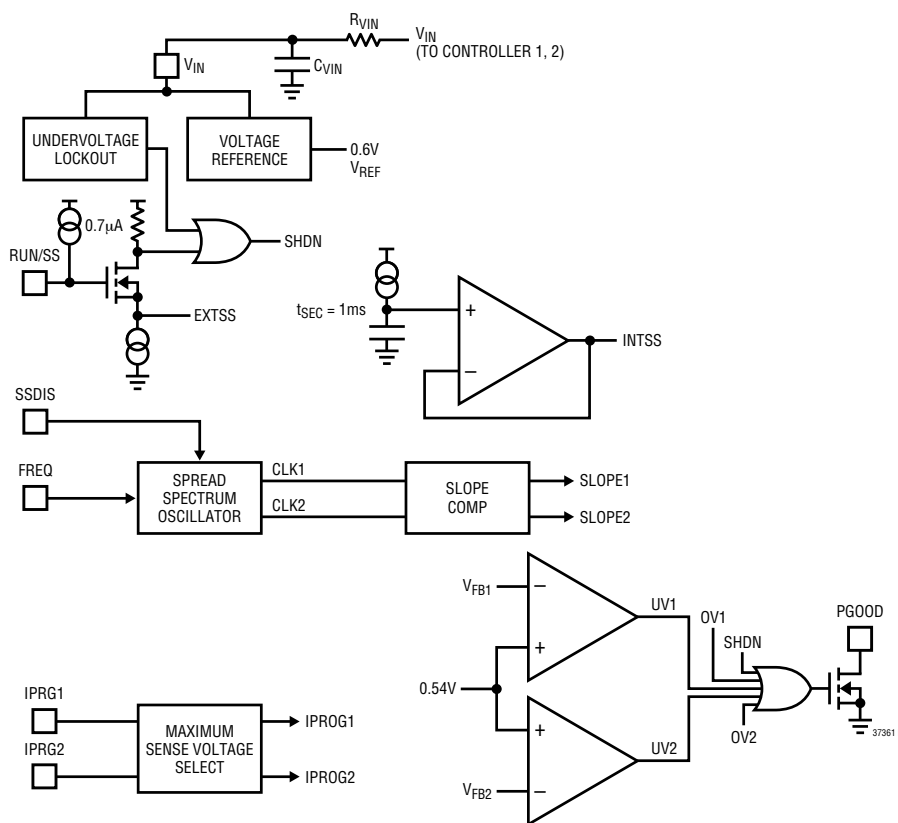

FUNCTIONAL DIAGRAM (Controller 2)

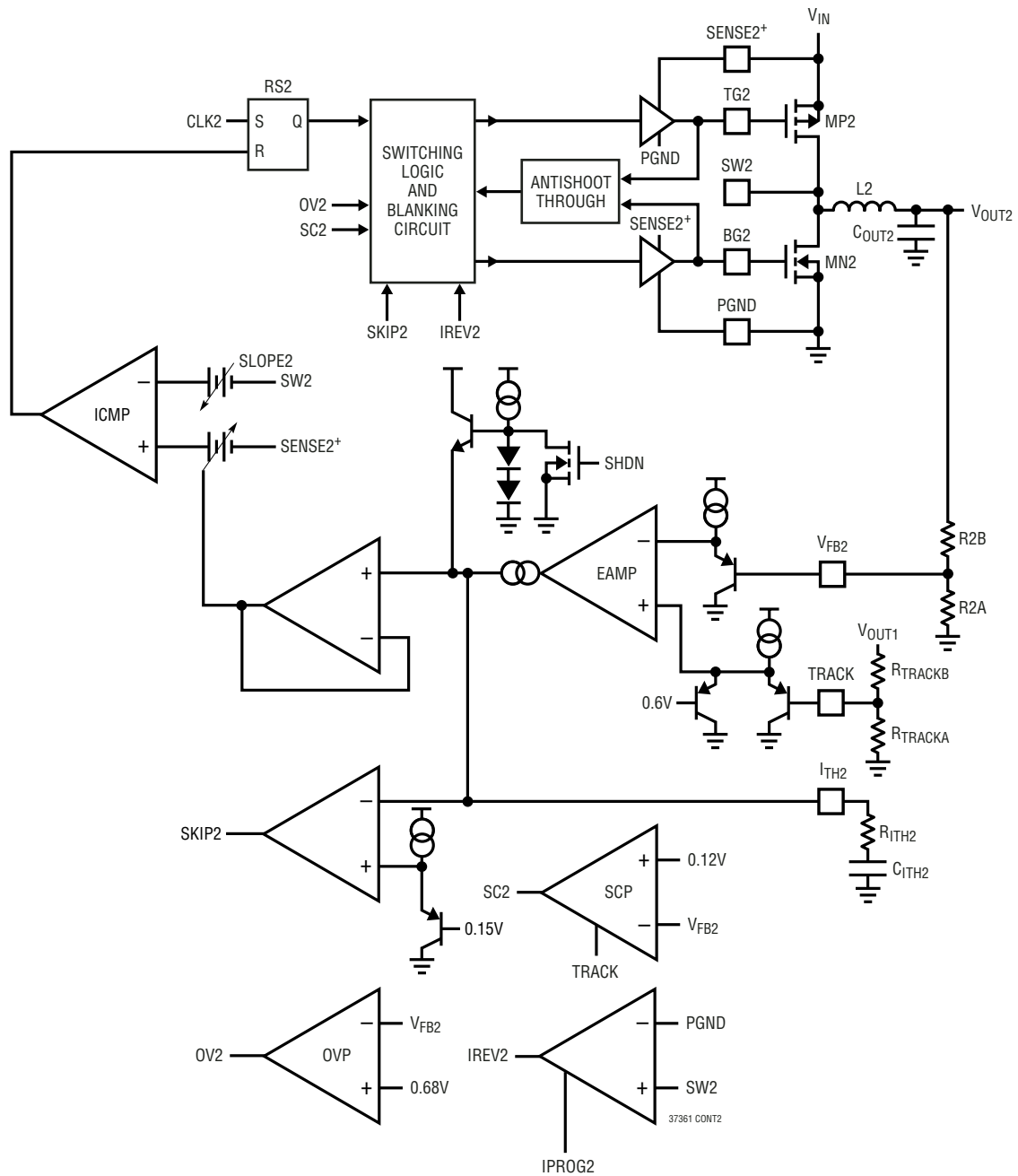

OPERATION (Refer to Functional Diagram)

Main Control Loop

The LTC3736-1 uses a current mode architecture with the two controllers operating 180 degrees out of phase. During normal operation, the top external P-channel power MOSFET is turned on when the clock for that channel sets the RS latch, and turned off when the current comparator (I_{CMP}) resets the latch. The peak inductor current at which I_{CMP} resets the RS latch is determined by the voltage on the I_{TH} pin, which is driven by the output of the error amplifier (EAMP). The V_{FB} pin receives the output voltage feedback signal from an external resistor divider. This feedback signal is compared to the internal 0.6V reference voltage by the EAMP. When the load current increases, it causes a slight decrease in V_{FB} relative to the 0.6V reference, which in turn causes the I_{TH} voltage to increase until the average inductor current matches the new load current. While the top P-channel MOSFET is off, the bottom N-channel MOSFET is turned on until either the inductor current starts to reverse, as indicated by the current reversal comparator, I_{RCMP} , or the beginning of the next cycle.

Shutdown, Soft-Start and Tracking Start-Up (RUN/SS and TRACK Pins)

The LTC3736-1 is shut down by pulling the RUN/SS pin low. In shutdown, all controller functions are disabled and the chip draws only 9 μ A. The TG outputs are held high (off) and the BG outputs low (off) in shutdown. Releasing RUN/SS allows an internal 0.7 μ A current source to charge up the RUN/SS pin. When the RUN/SS pin reaches 0.65V, the LTC3736-1's two controllers are enabled.

The start-up of V_{OUT1} is controlled by the LTC3736-1's internal soft-start. During soft-start, the error amplifier EAMP compares the feedback signal V_{FB1} to the internal soft-start ramp (instead of the 0.6V reference), which rises linearly from 0V to 0.6V in about 1ms. This allows the output voltage to rise smoothly from 0V to its final value, while maintaining control of the inductor current.

The 1ms soft-start time can be increased by connecting the optional external soft-start capacitor C_{SS} between the RUN/SS and SGND pins. As the RUN/SS pin continues to rise linearly from approximately 0.65V to 1.3V (being

charged by the internal 0.7 μ A current source), the EAMP regulates the V_{FB1} proportionally linearly from 0V to 0.6V.

The start-up of V_{OUT2} is controlled by the voltage on the TRACK pin. When the voltage on the TRACK pin is less than the 0.6V internal reference, the LTC3736-1 regulates the V_{FB2} voltage to the TRACK pin instead of the 0.6V reference. Typically, a resistor divider on V_{OUT1} is connected to the TRACK pin to allow the start-up of V_{OUT2} to "track" that of V_{OUT1} . For one-to-one tracking during start-up, the resistor divider would have the same ratio as the divider on V_{OUT2} that is connected to V_{FB2} .

Light Load Operation

The LTC3736-1 operates in PWM pulse skipping mode at light loads. In this mode, the current comparator I_{CMP} may remain tripped for several cycles and force the external P-channel MOSFET to stay off for the same number of cycles. The inductor current is not allowed to reverse (discontinuous operation). This mode exhibits low output ripple as well as low audio noise and reduced RF interference, while providing high light load efficiency.

Spread Spectrum Operation

Switching regulators can be particularly troublesome in applications where electromagnetic interference (EMI) is a concern. Switching regulators operate on a cycle-by-cycle basis to transfer power to an output. In most cases, the frequency of operation is either fixed or is a constant based on the output load. This method of conversion creates large components of noise at the frequency of operation (fundamental) and multiples of the operating frequency (harmonics). Figures 1a and 1b depict the output noise spectrum of a conventional buck switching converter (1/2 of LTC3736-1 with spread spectrum operation disabled) with $V_{IN} = 5V$, $V_{OUT} = 2.5V$ and $I_{OUT} = 2A$.

Unlike conventional buck converters, the LTC3736-1's internal oscillator is designed to produce a clock pulse whose frequency is randomly varied between 450kHz and 580kHz. This has the benefit of spreading the switching noise over a range of frequencies, thus significantly reducing the peak noise. Figures 1c and 1d show the output noise spectrum of the LTC3736-1 (with spread spectrum

OPERATION (Refer to Functional Diagram)

operation enabled) with $V_{IN} = 5V$, $V_{OUT} = 2.5V$ and $I_{OUT} = 1A$. Note the significant reduction in peak output noise (>20dBm).

Short-Circuit Protection

When an output is shorted to ground ($V_{FB} < 0.12V$), the switching frequency of that controller is reduced to 1/5 of the normal operating frequency. The other controller is unaffected and maintains normal operation.

The short-circuit threshold on V_{FB2} is based on the smaller of 0.12V and a fraction of the voltage on the TRACK pin. This also allows V_{OUT2} to start up and track V_{OUT1} more easily. Note that if V_{OUT1} is truly short-circuited ($V_{OUT1} = V_{FB1} = 0V$), then the LTC3736-1 will try to regulate V_{OUT2} to 0V if a resistor divider on V_{OUT1} is connected to the TRACK pin.

Output Overvoltage Protection

As a further protection, the overvoltage comparator (OV) guards against transient overshoots, as well as other more serious conditions that may overvoltage the output. When the feedback voltage on the V_{FB} pin has risen 13.33% above the reference voltage of 0.6V, the external P-channel MOSFET is turned off and the N-channel MOSFET is turned on until the overvoltage is cleared.

Frequency Selection (FREQ Pin) (Spread Spectrum Operation Disabled)

The switching frequency of the LTC3736-1 can be selected using the FREQ pin when spread spectrum operation is disabled (SSDIS = V_{IN}).

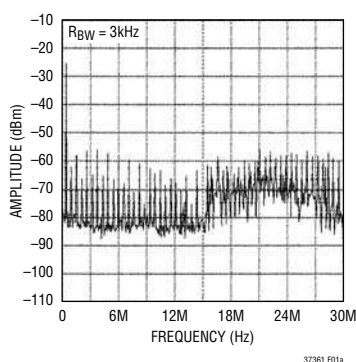

Figure 1a. Output Noise Spectrum of Conventional Buck Switching Converter (LTC3736-1 with Spread Spectrum Disabled) Showing Fundamental and Harmonic Frequencies

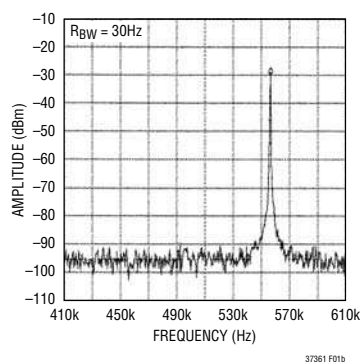

Figure 1b. Zoom-In of Fundamental Frequency of Conventional Buck Switching Converter

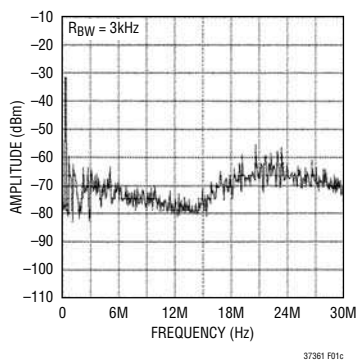

Figure 1c. Output Noise Spectrum of the LTC3736-1 Spread Spectrum Buck Switching Converter. Note the Reduction in Fundamental and Harmonic Peak Spectral Amplitude Compared to Figure 1a.

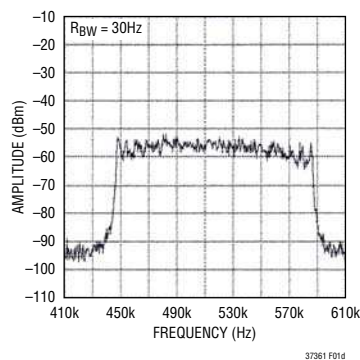

Figure 1d. Zoom-In of Fundamental Frequency of the LTC3736-1 Spread Spectrum Switching Converter. Note the >20dB Reduction in Peak Amplitude and Spreading of the Frequency Spectrum (Between Approximately 450kHz and 580kHz) Compared to Figure 1b.

OPERATION (Refer to Functional Diagram)

The FREQ pin can be floated, tied to V_{IN} or tied to SGND to select 550kHz, 750kHz or 300kHz respectively.

The selection of switching frequency is a tradeoff between efficiency and component size. Low frequency operation increases efficiency by reducing MOSFET switching losses, but requires larger inductance and/or capacitance to maintain low output ripple voltage.

Dropout Operation

When the input supply voltage (V_{IN}) decreases towards the output voltage, the rate of change of the inductor current while the external P-channel MOSFET is on (ON cycle) decreases. This reduction means that the P-channel MOSFET will remain on for more than one oscillator cycle if the inductor current has not ramped up to the threshold set by the EAMP on the I_{TH} pin. Further reduction in the input supply voltage will eventually cause the P-channel MOSFET to be turned on 100%; i.e., DC. The output voltage will then be determined by the input voltage minus the voltage drop across the P-channel MOSFET and the inductor.

Undervoltage Lockout

To prevent operation of the external MOSFETs below safe input voltage levels, an undervoltage lockout is incorporated in the LTC3736-1. When the input supply voltage (V_{IN}) drops below 2.3V, the external P- and N-channel MOSFETs and all internal circuitry are turned off except for the undervoltage block, which draws only a few microamperes.

Peak Current Sense Voltage Selection and Slope Compensation (IPRG1 and IPRG2 Pins)

When a controller is operating below 20% duty cycle, the peak current sense voltage (between the SENSE⁺ and SW pins) allowed across the external P-channel MOSFET is determined by:

$$\Delta V_{SENSE(MAX)} = \frac{A(V_{ITH} - 0.7V)}{10}$$

where A is a constant determined by the state of the IPRG pins. Floating the IPRG pin selects $A = 1$; tying IPRG to V_{IN} selects $A = 5/3$; tying IPRG to SGND selects $A = 2/3$. The maximum value of V_{ITH} is typically about 1.98V, so the

maximum sense voltage allowed across the external P-channel MOSFET is 125mV, 85mV or 204mV for the three respective states of the IPRG pin. The peak sense voltages for the two controllers can be independently selected by the IPRG1 and IPRG2 pins.

However, once the controller's duty cycle exceeds 20%, slope compensation begins and effectively reduces the peak sense voltage by a scale factor given by the curve in Figure 2.

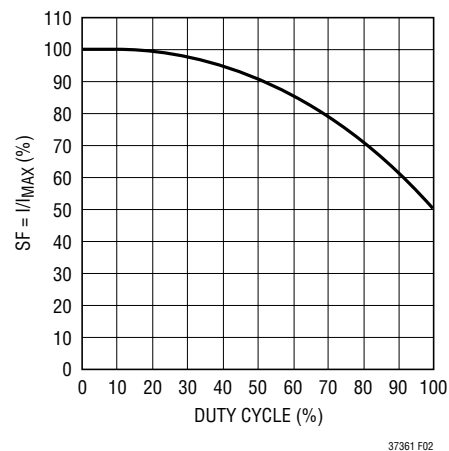

Figure 2. Maximum Peak Current vs Duty Cycle

The peak inductor current is determined by the peak sense voltage and the on-resistance of the external P-channel MOSFET:

$$I_{PK} = \frac{\Delta V_{SENSE(MAX)}}{R_{DS(ON)}}$$

Power Good (PGOOD) Pin

A window comparator monitors both feedback voltages and the open-drain PGOOD output pin is pulled low when either or both feedback voltages are not within $\pm 10\%$ of the 0.6V reference voltage. PGOOD is low when the LTC3736-1 is shut down or in undervoltage lockout.

2-Phase Operation

Why the need for 2-phase operation? Until recently, constant frequency dual switching regulators operated both controllers in phase (i.e., single phase operation). This means that both topside MOSFETs (P-channel) are turned

OPERATION (Refer to Functional Diagram)

on at the same time, causing current pulses of up to twice the amplitude of those from a single regulator to be drawn from the input capacitor. These large amplitude pulses increase the total RMS current flowing in the input capacitor, requiring the use of larger and more expensive input capacitors, and increase both EMI and power losses in the input capacitor and input power supply.

With 2-phase operation, the two controllers of the LTC3736-1 are operated 180 degrees out of phase. This effectively interleaves the current pulses coming from the topside MOSFET switches, greatly reducing the time where they overlap and add together. The result is a significant reduction in the total RMS current, which in turn allows the use of smaller, less expensive input capacitors, reduces shielding requirements for EMI and improves real world operating efficiency.

Figure 3 shows qualitatively example waveforms for a single phase dual controller versus a 2-phase LTC3736-1 system. In this case, 2.5V and 1.8V outputs, each drawing a load current of 2A, are derived from a 7V (e.g., a 2-cell Li-Ion battery) input supply. In this example, 2-phase

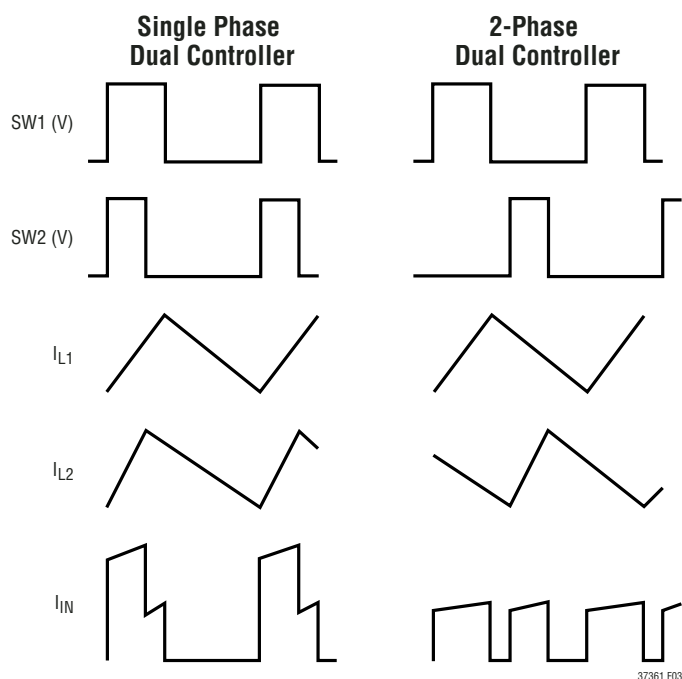

Figure 3. Example Waveforms for a Single Phase Dual Controller vs the 2-Phase LTC3736-1

operation would reduce the RMS input capacitor current from $1.79A_{RMS}$ to $0.91A_{RMS}$. While this is an impressive reduction by itself, remember that power losses are proportional to I_{RMS}^2 , meaning that actual power wasted is reduced by a factor of 3.86.

The reduced input ripple current also means that less power is lost in the input power path, which could include batteries, switches, trace/connector resistances, and protection circuitry. Improvements in both conducted and radiated EMI also directly accrue as a result of the reduced RMS input current and voltage. Significant cost and board footprint savings are also realized by being able to use smaller, less expensive, lower RMS current-rated input capacitors.

Of course, the improvement afforded by 2-phase operation is a function of the relative duty cycles of the two controllers, which in turn are dependent upon the input supply voltage. Figure 4 depicts how the RMS input current varies for single phase and 2-phase dual controllers with 2.5V and 1.8V outputs over a wide input voltage range.

It can be readily seen that the advantages of 2-phase operation are not limited to a narrow operating range, but in fact extend over a wide region. A good rule of thumb for most applications is that 2-phase operation will reduce the input capacitor requirement to that for just one channel operating at maximum current and 50% duty cycle.

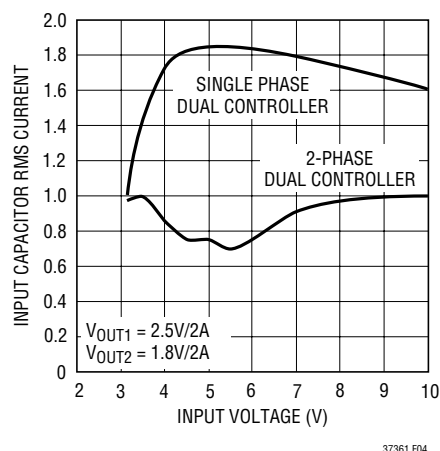

Figure 4. RMS Input Current Comparison

APPLICATIONS INFORMATION

The typical LTC3736-1 application circuit is shown in Figure 13. External component selection for each of the LTC3736-1's controllers is driven by the load requirement and begins with the selection of the inductor (L) and the power MOSFETs (MP and MN).

Power MOSFET Selection

Each of the LTC3736-1's two controllers requires two external power MOSFETs: a P-channel MOSFET for the topside (main) switch and an N-channel MOSFET for the bottom (synchronous) switch. Important parameters for the power MOSFETs are the breakdown voltage $V_{BR(DSS)}$, threshold voltage $V_{GS(TH)}$, on-resistance $R_{DS(ON)}$, reverse transfer capacitance C_{RSS} , turn-off delay $t_{D(OFF)}$ and the total gate charge Q_G .

The gate drive voltage is the input supply voltage. Since the LTC3736-1 is designed for operation down to low input voltages, a sublogic level MOSFET ($R_{DS(ON)}$ guaranteed at $V_{GS} = 2.5V$) is required for applications that work close to this voltage. When these MOSFETs are used, make sure that the input supply to the LTC3736-1 is less than the absolute maximum MOSFET V_{GS} rating, which is typically 8V.

The P-channel MOSFET's on-resistance is chosen based on the required load current. The maximum average output load current $I_{OUT(MAX)}$ is equal to the peak inductor current minus half the peak-to-peak ripple current I_{RIPPLE} . The LTC3736-1's current comparator monitors the drain-to-source voltage V_{DS} of the P-channel MOSFET, which is sensed between the SENSE+ and SW pins. The peak inductor current is limited by the current threshold, set by the voltage on the I_{TH} pin of the current comparator. The voltage on the I_{TH} pin is internally clamped, which limits the maximum current sense threshold $\Delta V_{SENSE(MAX)}$ to approximately 125mV when IPRG is floating (85mV when IPRG is tied low; 204mV when IPRG is tied high).

The output current that the LTC3736-1 can provide is given by:

$$I_{OUT(MAX)} = \frac{\Delta V_{SENSE(MAX)}}{R_{DS(ON)}} - \frac{I_{RIPPLE}}{2}$$

A reasonable starting point is setting ripple current I_{RIPPLE} to be 40% of $I_{OUT(MAX)}$. Rearranging the above equation yields:

$$R_{DS(ON)(MAX)} = \frac{5}{6} \cdot \frac{\Delta V_{SENSE(MAX)}}{I_{OUT(MAX)}}$$

for Duty Cycle < 20%.

However, for operation above 20% duty cycle, slope compensation has to be taken into consideration to select the appropriate value of $R_{DS(ON)}$ to provide the required amount of load current:

$$R_{DS(ON)(MAX)} = \frac{5}{6} \cdot SF \cdot \frac{\Delta V_{SENSE(MAX)}}{I_{OUT(MAX)}}$$

where SF is a scale factor whose value is obtained from the curve in Figure 1.

These must be further derated to take into account the significant variation in on-resistance with temperature. The following equation is a good guide for determining the required $R_{DS(ON)MAX}$ at 25°C (manufacturer's specification), allowing some margin for variations in the LTC3736-1 and external component values:

$$R_{DS(ON)(MAX)} = \frac{5}{6} \cdot 0.9 \cdot SF \cdot \frac{\Delta V_{SENSE(MAX)}}{I_{OUT(MAX)} \cdot \rho_T}$$

The ρ_T is a normalizing term accounting for the temperature variation in on-resistance, which is typically about 0.4%/°C, as shown in Figure 5. Junction to case temperature T_{JC} is about 10°C in most applications. For a maximum ambient temperature of 70°C, using $\rho_{80°C} \sim 1.3$ in the above equation is a reasonable choice.

The power dissipated in the top and bottom MOSFETs strongly depends on their respective duty cycles and load current. When the LTC3736-1 is operating in continuous mode, the duty cycles for the MOSFETs are:

$$\text{Top P-Channel Duty Cycle} = \frac{V_{OUT}}{V_{IN}}$$

$$\text{Bottom N-Channel Duty Cycle} = \frac{V_{IN} - V_{OUT}}{V_{IN}}$$

APPLICATIONS INFORMATION

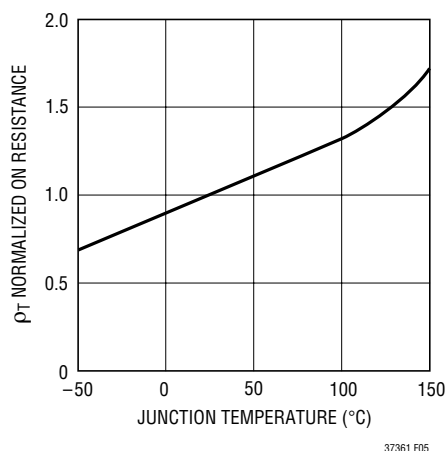

Figure 5. $R_{DS(ON)}$ vs Temperature

The MOSFET power dissipations at maximum output current are:

$$P_{TOP} = \frac{V_{OUT}}{V_{IN}} \cdot I_{OUT(MAX)}^2 \cdot \rho_T \cdot R_{DS(ON)} + 2 \cdot V_{IN}^2 \cdot I_{OUT(MAX)} \cdot C_{RSS} \cdot f_{OSC}$$

$$P_{BOT} = \frac{V_{IN} - V_{OUT}}{V_{IN}} \cdot I_{OUT(MAX)}^2 \cdot \rho_T \cdot R_{DS(ON)}$$

Both MOSFETs have I^2R losses and the P_{TOP} equation includes an additional term for transition losses, which are largest at high input voltages. The bottom MOSFET losses are greatest at high input voltage or during a short circuit when the bottom duty cycle is nearly 100%.

The LTC3736-1 utilizes a nonoverlapping, antishoot-through gate drive control scheme to ensure that the P- and N-channel MOSFETs are not turned on at the same time. To function properly, the control scheme requires that the MOSFETs used are intended for DC/DC switching applications. Many power MOSFETs, particularly P-channel MOSFETs, are intended to be used as static switches and therefore are slow to turn on or off.

Reasonable starting criteria for selecting the P-channel MOSFET are that it must typically have a gate charge (Q_G)

less than 25nC to 30nC (at 4.5V_{GS}) and a turn-off delay ($t_{D(OFF)}$) of less than approximately 140ns. However, due to differences in test and specification methods of various MOSFET manufacturers, and in the variations in Q_G and $t_{D(OFF)}$ with gate drive (V_{IN}) voltage, the P-channel MOSFET ultimately should be evaluated in the actual LTC3736-1 application circuit to ensure proper operation.

Shoot-through between the P-channel and N-channel MOSFETs can most easily be spotted by monitoring the input supply current. As the input supply voltage increases, if the input supply current increases dramatically, then the likely cause is shoot-through. Note that some MOSFETs that do not work well at high input voltages (e.g., $V_{IN} > 5V$) may work fine at lower voltages (e.g., 3.3V). Table 1 shows a selection of P-channel MOSFETs from different manufacturers that are known to work well in LTC3736-1 applications.

Selecting the N-channel MOSFET is typically easier, since for a given $R_{DS(ON)}$, the gate charge and turn-on and turn-off delays are much smaller than for a P-channel MOSFET.

Table 1. Selected P-Channel MOSFETs Suitable for LTC3736-1 Applications

| PART NUMBER | MANUFACTURER | TYPE | PACKAGE |
|--------------|--------------|-------------------|---------------|
| Si7540DP | Siliconix | Complementary P/N | PowerPak SO-8 |
| Si9801DY | Siliconix | Complementary P/N | SO-8 |
| FDW2520C | Fairchild | Complementary P/N | TSSOP-8 |
| FDW2521C | Fairchild | Complementary P/N | TSSOP-8 |
| Si3447BDV | Siliconix | Single P | TSOP-6 |
| Si9803DY | Siliconix | Single P | SO-8 |
| FDC602P | Fairchild | Single P | TSOP-6 |
| FDC606P | Fairchild | Single P | TSOP-6 |
| FDC638P | Fairchild | Single P | TSOP-6 |
| FDW2502P | Fairchild | Dual P | TSSOP-8 |
| FDS6875 | Fairchild | Dual P | SO-8 |
| HAT1054R | Hitachi | Dual P | SO-8 |
| NTMD6P02R2-D | On Semi | Dual P | SO-8 |

APPLICATIONS INFORMATION

Operating Frequency

When spread spectrum operation is enabled (SSDIS = GND), the frequency of the LTC3736-1 is randomly varied over the range of frequencies between 450kHz and 580kHz. In this case, a capacitor (1nF to 4.7nF) should be connected between the FREQ pin and SGND (or V_{IN}) to smooth out the changes in frequency. This not only provides a smoother frequency spectrum but also ensures that the switching regulator remains stable by preventing abrupt changes in frequency. A value of 2200pF is suitable in most applications.

When the spread spectrum operation is disabled (SSDIS = V_{IN}), the LTC3736-1's frequency may be selected from among three discrete, constant frequencies using the FREQ pin. Floating the FREQ pin selects 550kHz operation; tying this pin to V_{IN} selects 750kHz, while tying this pin to GND selects 300kHz. Table 2 summarizes the different states in which the FREQ pin can be used.

Table 2

| FREQ PIN | SSDIS PIN | FREQUENCY |
|------------------------------|-----------|------------------------------------|
| 0V | V_{IN} | 300kHz |
| Floating | V_{IN} | 550kHz |
| V_{IN} | V_{IN} | 750kHz |
| Capacitor to GND or V_{IN} | GND | Spread Spectrum (450kHz to 580kHz) |

Note that when spread spectrum operation is disabled, the LTC3736-1 operates like the standard, constant frequency LTC3736, except that at light loads, the LTC3736-1 operates in pulse skipping mode. This mode is not available on the LTC3736 unless the device is synchronized to an external clock signal using its phase-locked loop (PLL). Thus, if an LTC3736 with pulse skipping function is needed, then the LTC3736-1 with spread spectrum disabled is the appropriate solution. Table 3 summarizes the key differences in the available features on the LTC3736 and LTC3736-1.

Table 3

| AVAILABLE FEATURES/OPTIONS | LTC3736 | LTC3736-1 |
|-------------------------------|-------------------|-----------|
| Selectable Constant Frequency | Yes | Yes |
| Spread Spectrum | No | Yes |
| Synchronizable (PLL) | Yes | No |
| Burst Mode [®] | Yes | No |
| Forced Continuous Mode | Yes | No |
| Pulse Skipping Mode | When Synchronized | Yes |

Inductor Value Calculation

Given the desired input and output voltages, the inductor value and operating frequency f_{OSC} directly determine the inductor's peak-to-peak ripple current:

$$I_{RIPPLE} = \frac{V_{OUT}}{V_{IN}} \left(\frac{V_{IN} - V_{OUT}}{f_{OSC} \cdot L} \right)$$

Lower ripple current reduces core losses in the inductor, ESR losses in the output capacitors, and output voltage ripple. Thus, highest efficiency operation is obtained at low frequency with a small ripple current. Achieving this, however, requires a large inductor.

A reasonable starting point is to choose a ripple current that is about 40% of $I_{OUT(MAX)}$. Note that the largest ripple current occurs at the highest input voltage. To guarantee that ripple current does not exceed a specified maximum, the inductor should be chosen according to:

$$L \geq \frac{V_{IN} - V_{OUT}}{f_{OSC} \cdot I_{RIPPLE}} \cdot \frac{V_{OUT}}{V_{IN}}$$

Inductor Core Selection

Once the inductance value is determined, the type of inductor must be selected. High efficiency converters generally cannot afford the core loss found in low cost powdered iron cores, forcing the use of ferrite, molypermalloy or Kool M μ [®] cores. Actual core loss is independent of core size for a fixed inductor value, but it is very dependent on inductance selected. As inductance increases, core losses go down. Unfortunately, increased inductance requires more turns of wire and therefore copper losses will increase.

Ferrite designs have very low core loss and are preferred at high switching frequencies, so design goals can concentrate on copper loss and preventing saturation. Ferrite core material saturates "hard," which means that inductance collapses abruptly when the peak design current is exceeded. This results in an abrupt increase in inductor ripple current and consequent output voltage ripple. Do not allow the core to saturate!

Burst Mode is a registered trademark of Linear Technology Corporation.
Kool M μ is a registered trademark of Magnetics, Inc.

APPLICATIONS INFORMATION

Molypermalloy (from Magnetics, Inc.) is a very good, low loss core material for toroids, but it is more expensive than ferrite. A reasonable compromise from the same manufacturer is Kool M μ . Toroids are very space efficient, especially when you can use several layers of wire. Because they lack a bobbin, mounting is more difficult. However, designs for surface mount are available which do not increase the height significantly.

Schottky Diode Selection (Optional)

The Schottky diodes D1 and D2 in Figure 15 conduct current during the dead time between the conduction of the power MOSFETs. This prevents the body diode of the bottom N-channel MOSFET from turning on and storing charge during the dead time, which could cost as much as 1% in efficiency. A 1A Schottky diode is generally a good size for most LTC3736-1 applications, since it conducts a relatively small average current. Larger diodes result in additional transition losses due to their larger junction capacitance. This diode may be omitted if the efficiency loss can be tolerated.

C_{IN} and C_{OUT} Selection

The selection of C_{IN} is simplified by the 2-phase architecture and its impact on the worst-case RMS current drawn through the input network (battery/fuse/capacitor). It can be shown that the worst-case capacitor RMS current occurs when only one controller is operating. The controller with the highest (V_{OUT})(I_{OUT}) product needs to be used in the formula below to determine the maximum RMS capacitor current requirement. Increasing the output current drawn from the other controller will actually decrease the input RMS ripple current from its maximum value. The out-of-phase technique typically reduces the input capacitor's RMS ripple current by a factor of 30% to 70% when compared to a single phase power supply solution.

In continuous mode, the source current of the P-channel MOSFET is a square wave of duty cycle (V_{OUT})/(V_{IN}). To prevent large voltage transients, a low ESR capacitor sized for the maximum RMS current of one channel must be used. The maximum RMS capacitor current is given by:

$$C_{IN} \text{ Required } I_{RMS} \approx \frac{I_{MAX}}{V_{IN}} [(V_{OUT})(V_{IN} - V_{OUT})]^{1/2}$$

This formula has a maximum at V_{IN} = 2V_{OUT}, where I_{RMS} = I_{OUT}/2. This simple worst-case condition is commonly used for design because even significant deviations do not offer much relief. Note that capacitor manufacturers' ripple current ratings are often based on only 2000 hours of life. This makes it advisable to further derate the capacitor, or to choose a capacitor rated at a higher temperature than required. Several capacitors may be paralleled to meet size or height requirements in the design. Due to the high operating frequency of the LTC3736-1, ceramic capacitors can also be used for C_{IN}. Always consult the manufacturer if there is any question.

The benefit of the LTC3736-1 2-phase operation can be calculated by using the equation above for the higher power controller and then calculating the loss that would have resulted if both controller channels switched on at the same time. The total RMS power lost is lower when both controllers are operating due to the reduced overlap of current pulses required through the input capacitor's ESR. This is why the input capacitor's requirement calculated above for the worst-case controller is adequate for the dual controller design. Also, the input protection fuse resistance, battery resistance, and PC board trace resistance losses are also reduced due to the reduced peak currents in a 2-phase system. The overall benefit of a multiphase design will only be fully realized when the source impedance of the power supply/battery is included in the efficiency testing. The sources of the P-channel MOSFETs should be placed within 1cm of each other and share a common C_{IN}(s). Separating the sources and C_{IN} may produce undesirable voltage and current resonances at V_{IN}.

A small (0.1 μ F to 1 μ F) bypass capacitor between the chip V_{IN} pin and ground, placed close to the LTC3736-1, is also suggested. A 10 Ω resistor placed between C_{IN} (C1) and the V_{IN} pin provides further isolation between the two channels.

The selection of C_{OUT} is driven by the effective series resistance (ESR). Typically, once the ESR requirement is satisfied, the capacitance is adequate for filtering. The output ripple (Δ V_{OUT}) is approximated by:

$$\Delta V_{OUT} \approx I_{RIPPLE} \left(ESR + \frac{1}{8fC_{OUT}} \right)$$

APPLICATIONS INFORMATION

where f is the operating frequency, C_{OUT} is the output capacitance and I_{RIPPLE} is the ripple current in the inductor. The output ripple is highest at maximum input voltage since I_{RIPPLE} increases with input voltage.

Setting Output Voltage

The LTC3736-1 output voltages are each set by an external feedback resistor divider carefully placed across the output, as shown in Figure 6. The regulated output voltage is determined by:

$$V_{OUT} = 0.6V \cdot \left(1 + \frac{R_B}{R_A}\right)$$

To improve the frequency response, a feed-forward capacitor, C_{FF} , may be used. Great care should be taken to route the V_{FB} line away from noise sources, such as the inductor or the SW line. When spread spectrum operation is enabled, it is recommended that R_A and R_B be large-valued, preferably on the order of hundreds of kilohms.

Run/Soft Start Function

The RUN/SS pin is a dual purpose pin that provides the optional external soft-start function and a means to shut down the LTC3736-1.

Pulling the RUN/SS pin below 0.65V puts the LTC3736-1 into a low quiescent current shutdown mode ($I_Q = 9\mu A$). If RUN/SS has been pulled all the way to ground, there will be a delay before the LTC3736-1 comes out of shutdown and is given by:

$$t_{DELAY} = 0.65V \cdot \frac{C_{SS}}{0.7\mu A} = 0.93s/\mu F \cdot C_{SS}$$

This pin can be driven directly from logic as shown in Figure 6. Diode D1 in Figure 7 reduces the start delay but

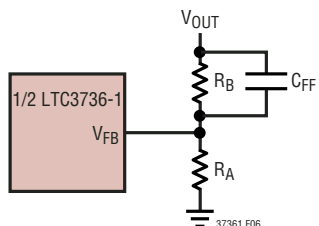

Figure 6. Setting Output Voltage

allows C_{SS} to ramp up slowly providing the soft-start function. This diode (and capacitor) can be deleted if the external soft-start is not needed.

During soft-start, the start-up of V_{OUT1} is controlled by slowly ramping the positive reference to the error amplifier from 0V to 0.6V, allowing V_{OUT1} to rise smoothly from 0V to its final value. The default internal soft-start time is 1ms. This can be increased by placing a capacitor between the RUN/SS pin and SGND. In this case, the soft-start time will be approximately:

$$t_{SS1} = C_{SS} \cdot \frac{600mV}{0.7\mu A}$$

It is recommended that C_{SS} have a value of at least twice that of the frequency filtering capacitor connected to the FREQ pin when spread spectrum operation is enabled (see Operation Frequency section).

Tracking

The start-up of V_{OUT2} is controlled by the voltage on the TRACK pin. Normally this pin is used to allow the start-up of V_{OUT2} to track that of V_{OUT1} as shown qualitatively in Figures 8a and 8b. When the voltage on the TRACK pin is less than the internal 0.6V reference, the LTC3736-1 regulates the V_{FB2} voltage to the TRACK pin voltage instead of 0.6V. The start-up of V_{OUT2} may ratiometrically track that of V_{OUT1} , according to a ratio set by a resistor divider (Figure 8c):

$$\frac{V_{OUT1}}{V_{OUT2}} = \frac{R_{2A}}{R_{TRACKA}} \cdot \frac{R_{TRACKA} + R_{TRACKB}}{R_{2B} + R_{2A}}$$

For coincident tracking ($V_{OUT1} = V_{OUT2}$ during start-up),

$$R_{2A}/R_{2B} = R_{TRACKA}/R_{TRACKB}$$

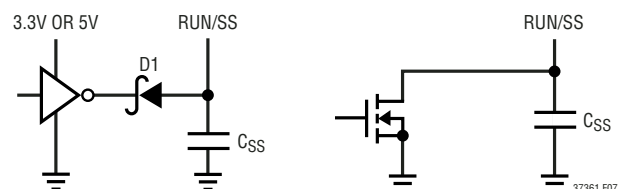

Figure 7. RUN/SS Pin Interfacing

APPLICATIONS INFORMATION

The ramp time for V_{OUT2} to rise from 0V to its final value is:

$$t_{SS2} = t_{SS1} \cdot \frac{R_{TRACKA}}{R1A} \cdot \frac{R1A + R1B}{R_{TRACKA} + R_{TRACKB}}$$

For coincident tracking,

$$t_{SS2} = t_{SS1} \cdot \frac{V_{OUT2F}}{V_{OUT1F}}$$

where V_{OUT1F} and V_{OUT2F} are the final, regulated values of V_{OUT1} and V_{OUT2} . V_{OUT1} should always be greater than

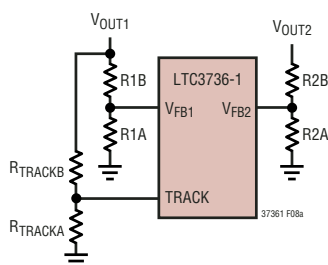
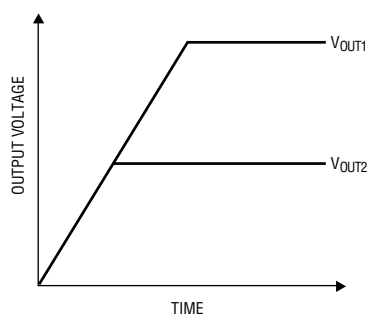
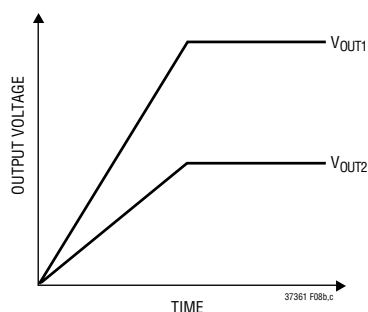

Figure 8a. Using the TRACK Pin



(8b) Coincident Tracking



(8c) Ratiometric Tracking

Figures 8b and 8c. Two Different Modes of Output Voltage Tracking

V_{OUT2} when using the TRACK pin. If no tracking function is desired, then the TRACK pin may be tied to V_{IN} . However, in this situation there would be no (internal nor external) soft-start on V_{OUT2} .

When using tracking with spread spectrum operation enabled, the tracking resistors R_{TRACKA} and R_{TRACKB} should have value at least 10 times smaller than corresponding feedback resistors $R2A$ and $R2B$.

Fault Condition: Short Circuit and Current Limit

To prevent excessive heating of the bottom MOSFET, foldback current limiting can be added to reduce the current in proportion to the severity of the fault.

Foldback current limiting is implemented by adding diodes D_{FB1} and D_{FB2} between the output and the I_{TH} pin as shown in Figure 9. In a hard short ($V_{OUT} = 0V$), the current will be reduced to approximately 50% of the maximum output current.

Low Supply Operation

Although the LTC3736-1 can function down to below 2.4V, the maximum allowable output current is reduced as V_{IN} decreases below 3V. Figure 10 shows the amount of

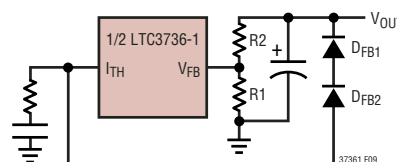

Figure 9. Foldback Current Limiting

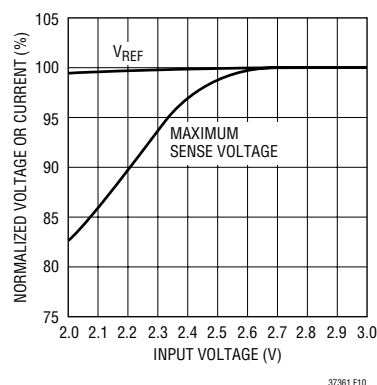

Figure 10. Line Regulation of V_{REF} and Maximum Sense Voltage for Low Input Supply

APPLICATIONS INFORMATION

change as the supply is reduced down to 2.4V. Also shown is the effect on V_{REF} .

Minimum On-Time Considerations

Minimum on-time, $t_{ON(MIN)}$, is the smallest amount of time in which the LTC3736-1 is capable of turning the top P-channel MOSFET on and then off. It is determined by internal timing delays and the gate charge required to turn on the top MOSFET. Low duty cycle and high frequency applications may approach the minimum on-time limit and care should be taken to ensure that:

$$t_{ON(MIN)} < \frac{V_{OUT}}{f_{OSC} \cdot V_{IN}}$$

If the duty cycle falls below what can be accommodated by the minimum on-time, the LTC3736-1 will begin to skip cycles. The output voltage will continue to be regulated, but the ripple current and ripple voltage will increase. The minimum on-time for the LTC3736-1 is typically about 250ns. However, as the peak sense voltage ($I_{L(PEAK)} \cdot R_{DS(ON)}$) decreases, the minimum on-time gradually increases up to about 300ns.

Efficiency Considerations

The efficiency of a switching regulator is equal to the output power divided by the input power times 100%. It is often useful to analyze individual losses to determine what is limiting efficiency and which change would produce the most improvement. Efficiency can be expressed as:

$$\text{Efficiency} = 100\% - (L1 + L2 + L3 + \dots)$$

where L1, L2, etc. are the individual losses as a percentage of input power.

Although all dissipative elements in the circuit produce losses, five main sources usually account for most of the losses in LTC3736-1 circuits: 1) LTC3736-1 DC bias current, 2) MOSFET gate charge current, 3) I^2R losses, and 4) transition losses.

- 1) The V_{IN} (pin) current is the DC supply current, given in the electrical characteristics, excluding MOSFET driver currents. V_{IN} current results in a small loss that increases with V_{IN} .

- 2) MOSFET gate charge current results from switching the gate capacitance of the power MOSFETs. Each time a MOSFET gate is switched from low to high to low again, a packet of charge dQ moves from $SENSE^+$ to ground. The resulting dQ/dt is a current out of $SENSE^+$, which is typically much larger than the DC supply current. In continuous mode, $I_{GATECHG} = f \cdot Q_P$.
- 3) I^2R losses are calculated from the DC resistances of the MOSFETs and inductor. In continuous mode, the average output current flows through L but is “chopped” between the top P-channel MOSFET and the bottom N-channel MOSFET. The MOSFET $R_{DS(ON)}$ s multiplied by duty cycle can be summed with the resistance of L to obtain I^2R losses.
- 4) Transition losses apply to the top external P-channel MOSFET and increase with higher operating frequencies and input voltages. Transition losses can be estimated from:

$$\text{Transition Loss} = 2 (V_{IN})^2 I_{O(MAX)} C_{RSS}(f)$$

Other losses, including C_{IN} and C_{OUT} ESR dissipative losses and inductor core losses, generally account for less than 2% total additional loss.

Checking Transient Response

The regulator loop response can be checked by looking at the load transient response. Switching regulators take several cycles to respond to a step in load current. When a load step occurs, V_{OUT} immediately shifts by an amount equal to $(\Delta I_{LOAD})(ESR)$, where ESR is the effective series resistance of C_{OUT} . ΔI_{LOAD} also begins to charge or discharge C_{OUT} , which generates a feedback error signal. The regulator loop then returns V_{OUT} to its steady-state value. During this recovery time, V_{OUT} can be monitored for overshoot or ringing. OPTI-LOOP compensation allows the transient response to be optimized over a wide range of output capacitance and ESR values.

The I_{TH} series R_C - C_C filter (see Functional Diagram) sets the dominant pole-zero loop compensation. The I_{TH} external components shown in the Typical Application on the front page of this data sheet will provide an adequate starting point for most applications. The values can be

APPLICATIONS INFORMATION

modified slightly (from 0.2 to 5 times their suggested values) to optimize transient response once the final PC layout is done and the particular output capacitor type and value have been determined. The output capacitors need to be decided upon because the various types and values determine the loop feedback factor gain and phase. An output current pulse of 20% to 100% of full load current having a rise time of $1\mu\text{s}$ to $10\mu\text{s}$ will produce output voltage and I_{TH} pin waveforms that will give a sense of the overall loop stability. The gain of the loop will be increased by increasing R_C , and the bandwidth of the loop will be increased by decreasing C_C . The output voltage settling behavior is related to the stability of the closed-loop system and will demonstrate the actual overall supply performance. For a detailed explanation of optimizing the compensation components, including a review of control loop theory, refer to Application Note 76.

A second, more severe transient is caused by switching in loads with large ($>1\mu\text{F}$) supply bypass capacitors. The discharged bypass capacitors are effectively put in parallel with C_{OUT} , causing a rapid drop in V_{OUT} . No regulator can

deliver enough current to prevent this problem if the load switch resistance is low and it is driven quickly. The only solution is to limit the rise time of the switch drive so that the load rise time is limited to approximately $(25)(C_{\text{LOAD}})$. Thus a $10\mu\text{F}$ capacitor would require a $250\mu\text{s}$ rise time, limiting the charging current to about 200mA.

PC Board Layout Checklist

When laying out the printed circuit board, the following checklist should be used to ensure proper operation of the LTC3736-1. These items are illustrated in the layout diagram of Figure 11. Figure 12 depicts the current waveforms present in the various branches of the 2-phase dual regulator.

1) The power loop (input capacitor, MOSFETs, inductor, output capacitor) of each channel should be as small as possible and isolated as much as possible from the power loop of the other channel. Ideally, the drains of the P- and N-channel FETs should be connected close to one another with an input capacitor placed across the FET sources (from the P-channel source to the N-channel source) right

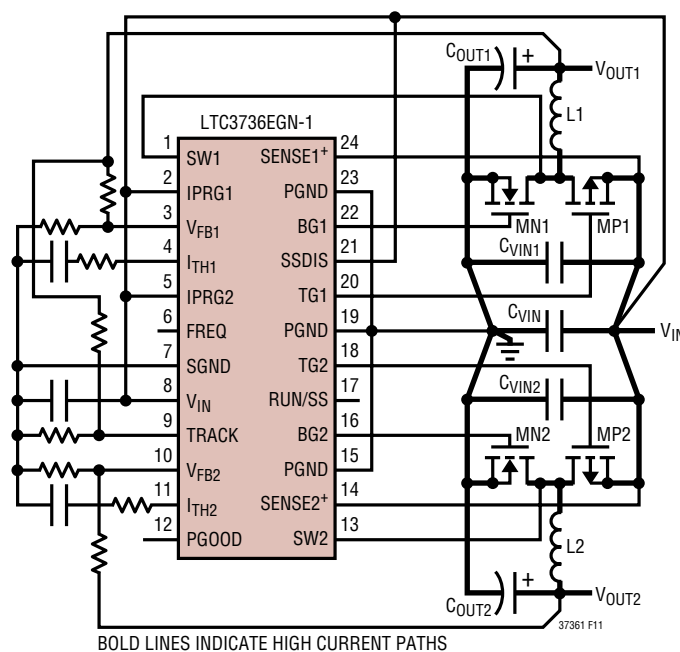

Figure 11. LTC3736-1 Layout Diagram

APPLICATIONS INFORMATION

at the FETs. It is better to have two separate, smaller valued input capacitors (e.g., two $10\mu\text{F}$ —one for each channel) than it is to have a single larger valued capacitor (e.g., $22\mu\text{F}$) that the channels share with a common connection.

2) The signal and power grounds should be kept separate. The signal ground consists of the feedback resistor dividers, I_{TH} compensation networks and the SGND pin.

The power grounds consist of the (-) terminal of the input and output capacitors and the source of the N-channel MOSFET. Each channel should have its own power ground for its power loop (as described in (1) above). The power grounds for the two channels should connect together at a common point. It is most important to keep the ground paths with high switching currents away from each other.

The PGND pins on the LTC3736-1 IC should be shorted together and connected to the common power ground connection (away from the switching currents).

3) Put the feedback resistors close to the V_{FB} pins. The trace connecting the top feedback resistor (R_{B}) to the output capacitor should be a Kelvin trace. The I_{TH} compensation components should also be very close to the LTC3736-1.

4) The current sense traces (SENSE⁺ and SW) should be Kelvin connections right at the P-channel MOSFET source and drain.

5) Keep the switch nodes (SW1, SW2) and the gate driver nodes (TG1, TG2, BG1, BG2) away from the small-signal components, especially the opposite channels feedback resistors, I_{TH} compensation components and the current sense pins (SENSE⁺ and SW).

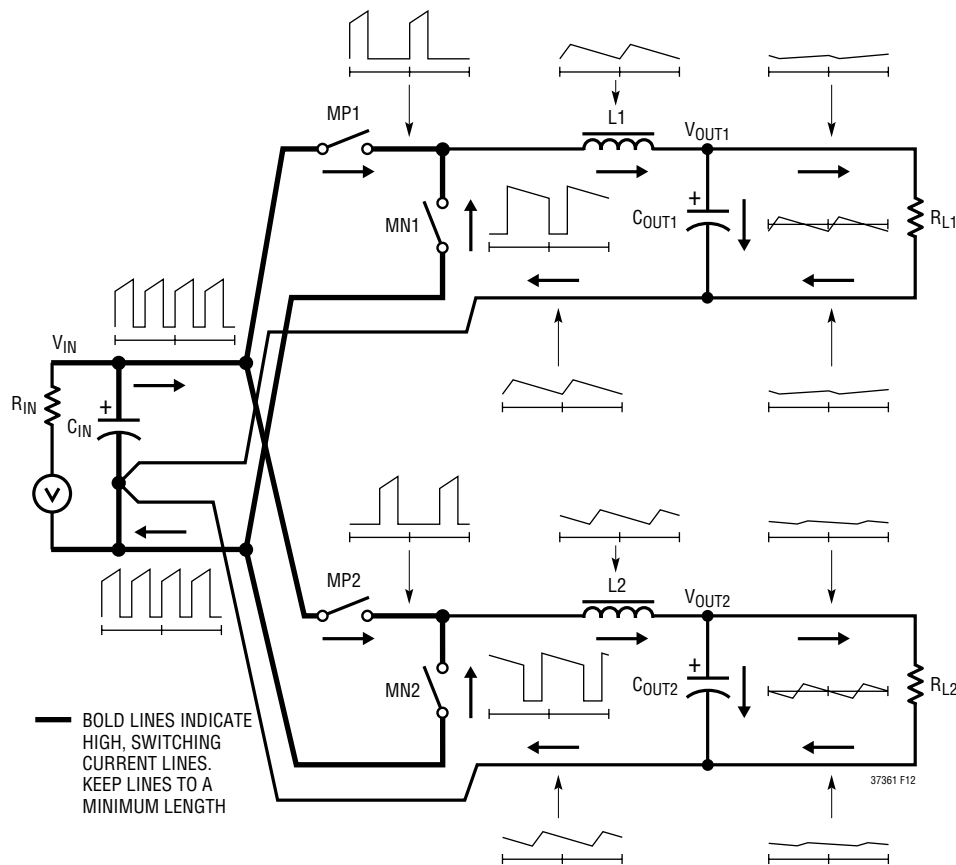

Figure 12. Branch Current Waveforms

TYPICAL APPLICATIONS

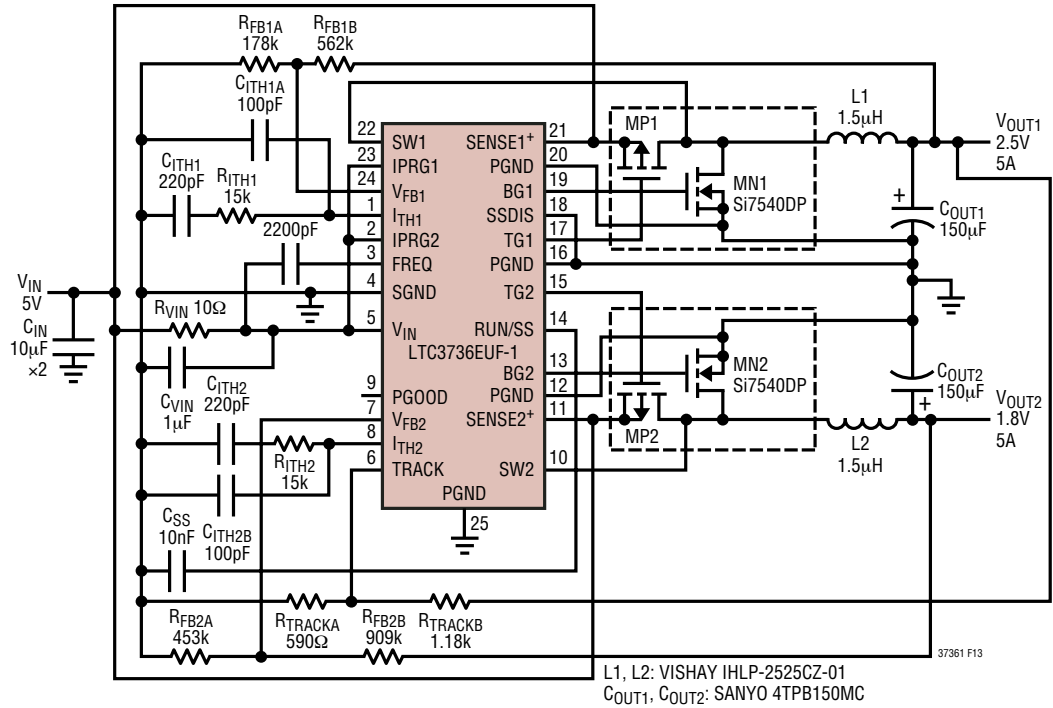

Figure 13. 2-Phase, Spread Spectrum, Dual Output Synchronous DC/DC Converter

TYPICAL APPLICATIONS

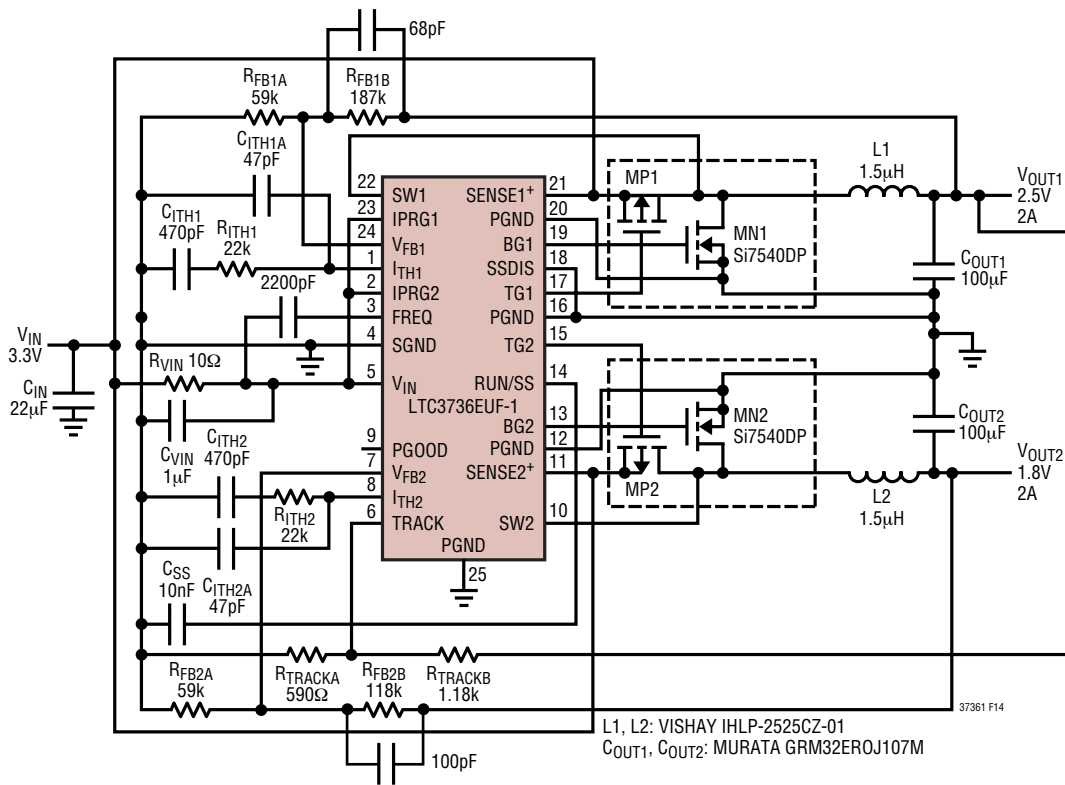
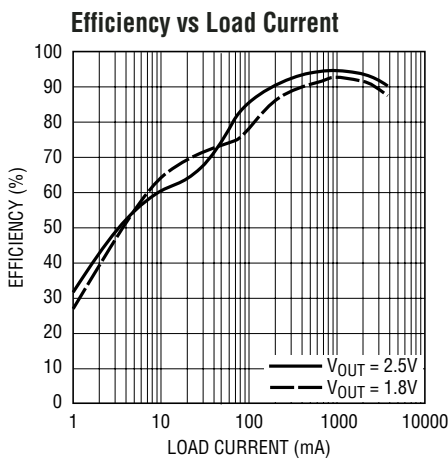
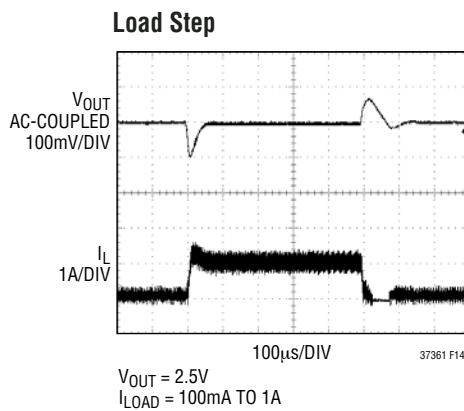

Figure 14. 2-Phase, Spread Spectrum, Dual Output Synchronous DC/DC Converter with Ceramic Output Capacitors



37361 F14b



37361 F14c

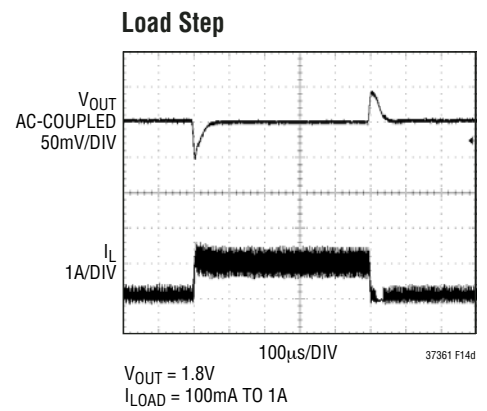

37361 F14d

TYPICAL APPLICATIONS

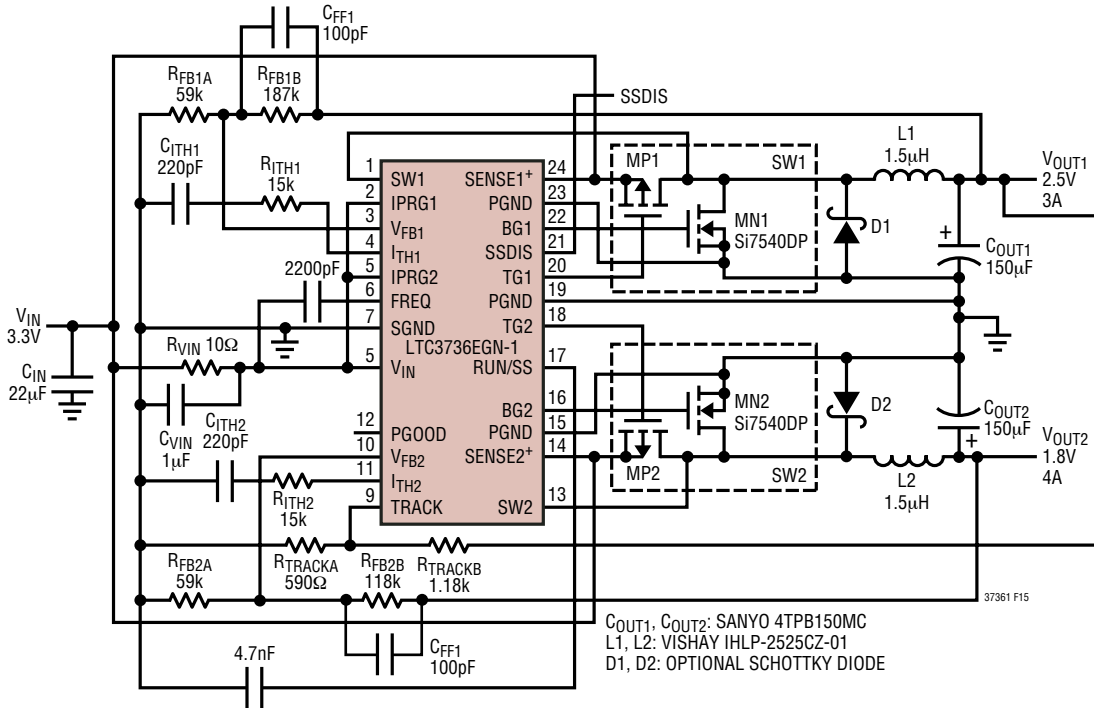
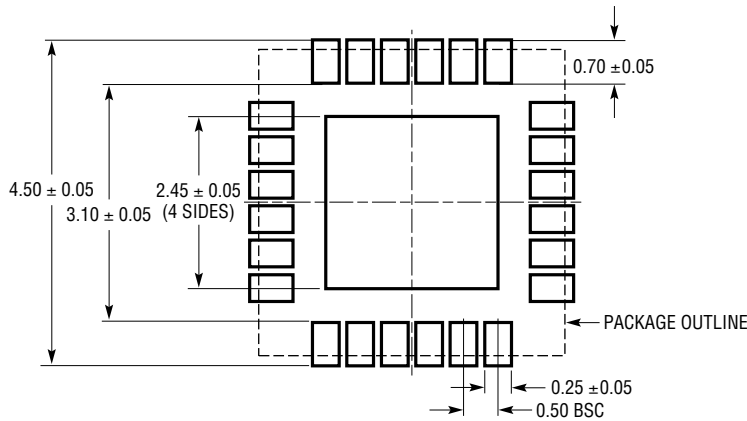

Figure 15. 2-Phase, Fixed 550kHz or Spread Spectrum, Dual Output Synchronous DC/DC Converter

PACKAGE DESCRIPTION

UF Package
24-Lead Plastic QFN (4mm × 4mm)
 (Reference LTC DWG # 05-08-1697)



RECOMMENDED SOLDER PAD PITCH AND DIMENSIONS

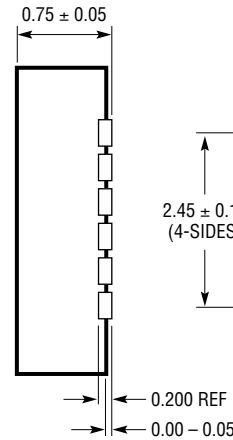
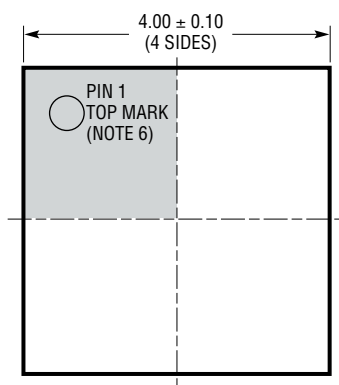

BOTTOM VIEW—EXPOSED PAD

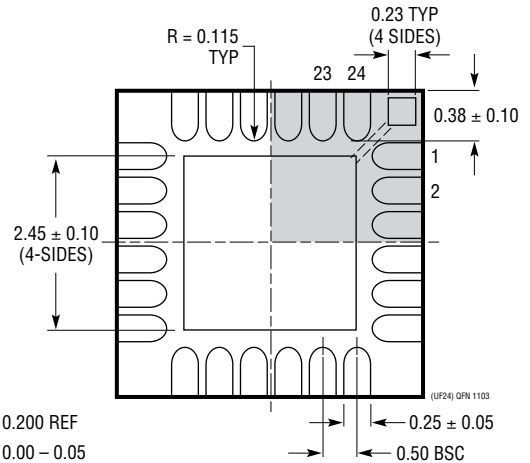

NOTE:

1. DRAWING PROPOSED TO BE MADE A JEDEC PACKAGE OUTLINE MO-220 VARIATION (WGGD-X)—TO BE APPROVED
2. DRAWING NOT TO SCALE
3. ALL DIMENSIONS ARE IN MILLIMETERS
4. DIMENSIONS OF EXPOSED PAD ON BOTTOM OF PACKAGE DO NOT INCLUDE MOLD FLASH. MOLD FLASH, IF PRESENT, SHALL NOT EXCEED 0.15mm ON ANY SIDE, IF PRESENT
5. EXPOSED PAD SHALL BE SOLDER PLATED
6. SHADED AREA IS ONLY A REFERENCE FOR PIN 1 LOCATION ON THE TOP AND BOTTOM OF PACKAGE

TYPICAL APPLICATION

2-Phase, Spread Spectrum Dual Output, Synchronous DC/DC Converter

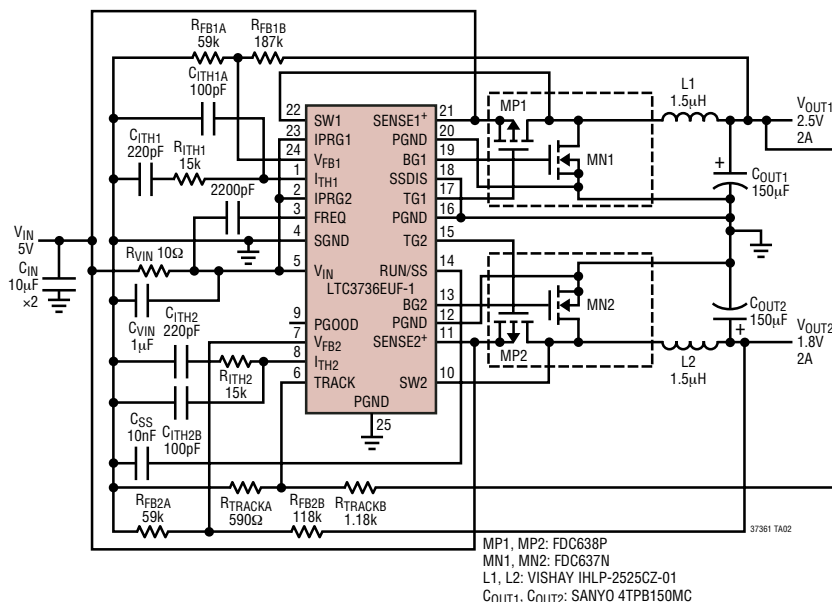

RELATED PARTS

| PART NUMBER | DESCRIPTION | COMMENTS |
|------------------------|-----------------------------------------------------------------------------|------------------------------------------------------------------------------------------------------------|
| LTC1628/ LTC1628-PG | Dual High Efficiency, 2-Phase Synchronous Step-Down Controllers | Constant Frequency, Standby, 5V and 3.3V LDOs, V_{IN} to 36V, 28-Lead SSOP |
| LTC1735 | High Efficiency Synchronous Step-Down Controller | Burst Mode Operation, 16-Pin Narrow SSOP, Fault Protection, $3.5V \leq V_{IN} \leq 36V$ |
| LTC1772 | Constant Frequency Current Mode Step-Down DC/DC Controller | $2.5V \leq V_{IN} \leq 9.8V$, I_{OUT} Up to 4A, SOT-23 Package, 550kHz |
| LTC1773 | Synchronous Step-Down Controller | $2.65V \leq V_{IN} \leq 8.5V$, I_{OUT} Up to 4A, 10-Lead MSOP |
| LTC1778 | No R_{SENSE}^{TM} Synchronous Step-Down Controller | Current Mode Operation Without Sense Resistor, Fast Transient Response, $4V \leq V_{IN} \leq 36V$ |
| LTC2923 | Power Supply Tracking Controller | Controls Up to Three Supplies, 10-Lead MSOP |
| LTC3251 Series | 500mA High Efficiency, Low Noise, Inductorless Step-Down DC/DC Converters | 2-Phase, Spread Spectrum Operation, 10-Pin MSOP Package |
| LTC3252 | Dual, Low Noise, Inductorless Step-Down DC/DC Converter | Spread Spectrum Operation, 4mm x 3mm 12-Pin DFN Package |
| LTC3416 | 4A, 4MHz, Synchronous Step-Down DC/DC Converter with Output Tracking | 95% Efficiency, V_{IN} : 2.25V to 5.5V, $I_{SD} < 1\mu A$, TSSOP-20E Package |
| LTC3701 | 2-Phase, Low Input Voltage Dual Step-Down DC/DC Controller | $2.5V \leq V_{IN} \leq 9.8V$, 550kHz, PGOOD, PLL, 16-Lead SSOP |
| LTC3708 | Fast 2-Phase, No R_{SENSE} Buck Controller with Output Tracking | Constant On-Time Dual Controller, V_{IN} Up to 36V, Very Low Duty Cycle Operation, 5mm x 5mm QFN Package |
| LTC3728/LTC3728L | Dual, 550kHz, 2-Phase, Synchronous Step-Down Switching Regulator | Constant Frequency, V_{IN} to 36V, 5V and 3.3V LDOs, 5mm x 5mm QFN or 28-Lead SSOP |
| LTC3736 | Dual, 2-Phase, No R_{SENSE} , Synchronous Controller with Output Tracking | V_{IN} : 2.75V to 9.8V, I_{OUT} Up to 5A, 4mm x 4mm QFN Package |
| LTC3737 | Dual, 2-Phase, No R_{SENSE} Controller with Output Tracking | V_{IN} : 2.75V to 9.8V, I_{OUT} Up to 5A, 4mm x 4mm QFN Package |
| LTC6902 | Multiphase Oscillator with Spread Spectrum Frequency Modulation | Resistor Programs Nominal Frequency and Spreading; 2-, 3-, or 4-Phase Outputs; 10-Pin MSOP Package |

No R_{SENSE} is a trademark of Linear Technology Corporation.