

# Micropower High Efficiency 5V/12V Step-Up DC/DC Converter for Flash Memory

## FEATURES

- 12V at 120mA from 5V or 3.3V Supply
- Supply Voltage as Low as 1.8V
- Better High Current Efficiency Than CMOS
- Up to 89% Efficiency
- 120 $\mu$ A Quiescent Current
- Shutdown to 10 $\mu$ A
- Programmable 5V or 12V Output
- Low  $V_{CESAT}$  Switch: 170mV at 1A Typical
- $I_{LIM}$  Pin Programs Peak Switch Current
- Uses Inexpensive Surface Mount Inductors
- 8-Lead DIP or SOIC Package

## APPLICATIONS

- Flash Memory  $V_{PP}$  Generator
- Palmtop Computers
- Portable Instruments
- Bar-Code Scanners
- Personal Digital Assistants
- PCMCIA Cards

## DESCRIPTION

The LT1301 is a micropower step-up DC/DC converter that utilizes Burst Mode™ operation. The device can deliver 5V or 12V from a two-cell battery input. It features programmable 5V or 12V output via a logic-controlled input, no-load quiescent current of 120 $\mu$ A and a shutdown pin which reduces supply current to 10 $\mu$ A. The on-chip power switch has a low 170mV saturation voltage at a switch current of 1A, a four-fold reduction over prior designs. A 155kHz internal oscillator allows the use of extremely small surface mount inductors and capacitors. Operation is guaranteed at 1.8V input. This allows more energy to be extracted from the battery, increasing operating life. The  $I_{LIM}$  pin can be used for soft start or to program peak switch current with a single resistor allowing the use of even smaller inductors in lighter load applications. The LT1301 is available in an 8-lead SOIC package, minimizing board space requirements. For a selectable 3.3V/5V step-up converter, please see the LT1300. For higher output power, see the LT1302.

Burst Mode is a trademark of Linear Technology Corporation.

## TYPICAL APPLICATIONS

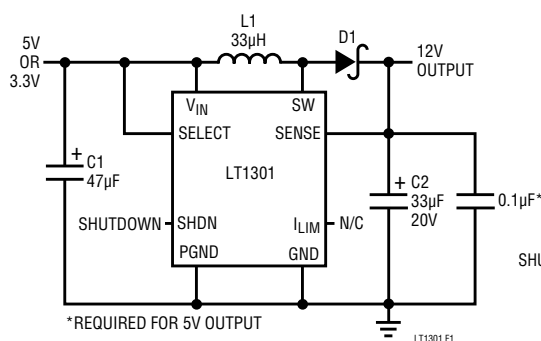

\*REQUIRED FOR 5V OUTPUT

L1 = COILCRAFT D03316-333  
OR SUMIDA CD73-330KC

D1 = 1N5817 OR MOTOROLA  
MBRS130LT3

C1 = AVX TPSD476M016R0100  
OR SANYO OS-CON 165A47M

C2 = AVX TPSD336M020R0100  
OR SANYO OS-CON 205A33M

### Output Voltage

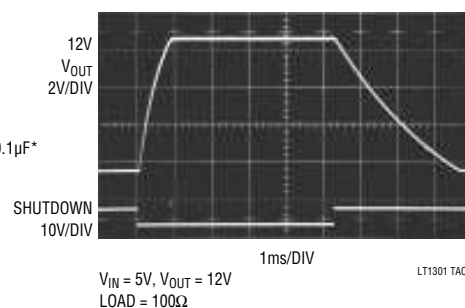

### Efficiency

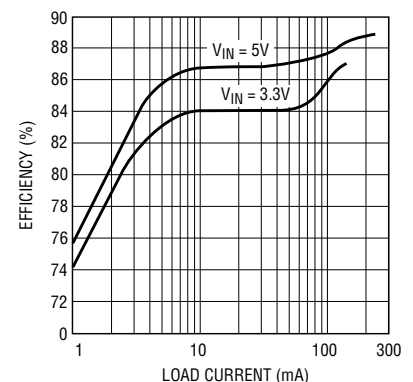

Figure 1. 3.3V/5V to 12V Step-Up Converter

LT1300 F2

**ABSOLUTE MAXIMUM RATINGS**

$V_{IN}$ Voltage .....	10V
SW1 Voltage .....	20V
Sense Voltage .....	20V
Shutdown Voltage .....	10V
Select Voltage .....	10V
$I_{LIM}$ Voltage .....	0.5V
Maximum Power Dissipation .....	500mW
Operating Temperature Range	
LT1301C .....	0°C to 70°C
LT1301I .....	40°C to 85°C
Storage Temperature Range .....	-65°C to 150°C
Lead Temperature (Soldering, 10 sec).....	300°C

**PACKAGE/ORDER INFORMATION**

<p>TOP VIEW</p>	ORDER PART NUMBER
	<p>LT1301CN8 LT1301CS8 LT1301IS8</p>
	S8 PART MARKING
	<p>1301 1301I</p>

**ELECTRICAL CHARACTERISTICS**  $T_A = 25^\circ\text{C}$ ,  $V_{IN} = 2\text{V}$  unless otherwise noted.

SYMBOL	PARAMETER	CONDITIONS	MIN	TYP	MAX	UNITS	
$I_Q$	Quiescent Current	$V_{SHDN} = 0.5\text{V}$ , $V_{SEL} = 5\text{V}$ , $V_{SENSE} = 5.5\text{V}$ $V_{SHDN} = 1.8\text{V}$	●	120	200	$\mu\text{A}$	
			●	7	15	$\mu\text{A}$	
$V_{IN}$	Input Voltage Range		●	1.8		V	
			●	2.0		V	
$V_{OUT}$	Output Sense Voltage	$V_{SEL} = 5\text{V}$ $V_{SEL} = 0\text{V}$	●	11.52	12.00	12.48	V
			●	4.75	5.00	5.25	V
	Output Referred Comparator Hysteresis	$V_{SEL} = 5\text{V}$ (Note 1) $V_{SEL} = 0\text{V}$ (Note 1)	●	50	100	mV	
			●	22	50	mV	
	Oscillator Frequency	Current Limit not Asserted.		120	155	185	kHz
	Oscillator TC			0.2		%/ $^\circ\text{C}$	
DC	Maximum Duty Cycle		75	86	95	%	
$t_{ON}$	Switch On-Time	Current Limit not Asserted.		5.6		$\mu\text{s}$	
	Output Line Regulation	$1.8\text{V} < V_{IN} < 6\text{V}$	●	0.06	0.15	%/V	
$V_{CESAT}$	Switch Saturation Voltage	$I_{SW} = 700\text{mA}$	●	130	200	mV	
	Switch Leakage Current	$V_{SW} = 5\text{V}$ , Switch Off	●	0.1	10	$\mu\text{A}$	
	Peak Switch Current (Internal Trip Point)	$I_{LIM}$ Floating (See Typical Application) $I_{LIM}$ Grounded		0.75	1.0	1.25	A
					0.4		A
$V_{SHDNH}$	Shutdown Pin High		●	1.8		V	
$V_{SHDNL}$	Shutdown Pin Low				0.5	V	
$V_{SE LH}$	Select Pin High		●	1.5		V	
$V_{SE LL}$	Select Pin Low		●		0.8	V	
$I_{SHDN}$	Shutdown Pin Bias Current	$V_{SHDN} = 5\text{V}$ $V_{SHDN} = 2\text{V}$ $V_{SHDN} = 0\text{V}$	●	8	20	$\mu\text{A}$	
			●	3		$\mu\text{A}$	
			●	0.1	1	$\mu\text{A}$	
$I_{SEL}$	Select Pin Bias Current	$0\text{V} < V_{SEL} < 5\text{V}$	●	1	3	$\mu\text{A}$	

The ● denotes specifications which apply over the 0°C to 70°C temperature range.

**Note 1:** Hysteresis specified is DC. Output ripple may be higher if output capacitance is insufficient or capacitor ESR is excessive. See operation section.

# TYPICAL PERFORMANCE CHARACTERISTICS

**5V Output Efficiency**

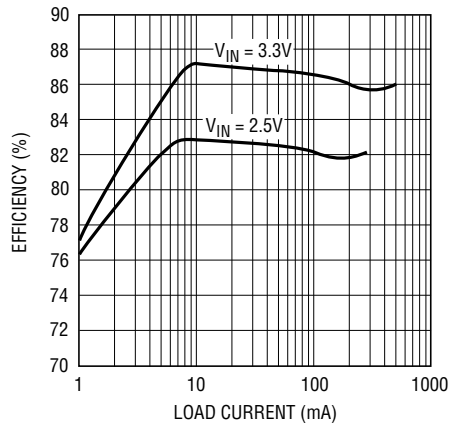

LT1301 G1

**Total Quiescent Current in Shutdown**

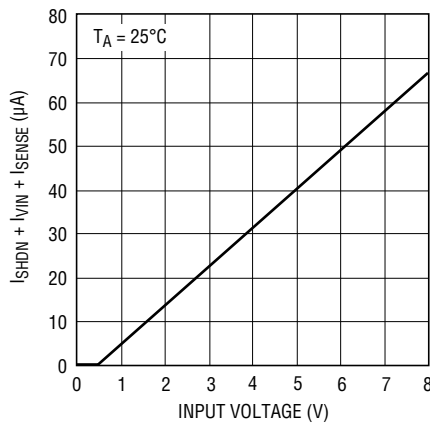

LT1301 G2

**Shutdown Pin Bias Current**

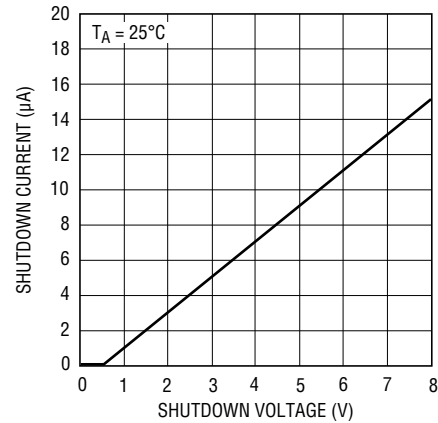

LT1301 G3

**Saturation Voltage vs Switch Current**

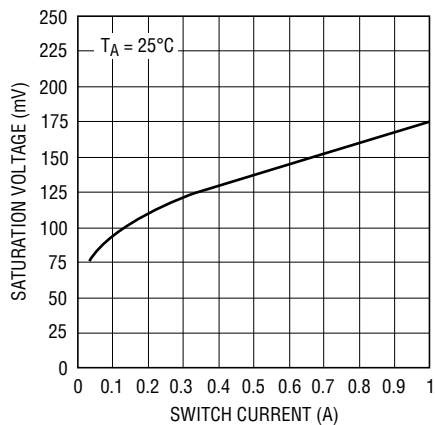

LT1301 G4

**No-Load Input Current**

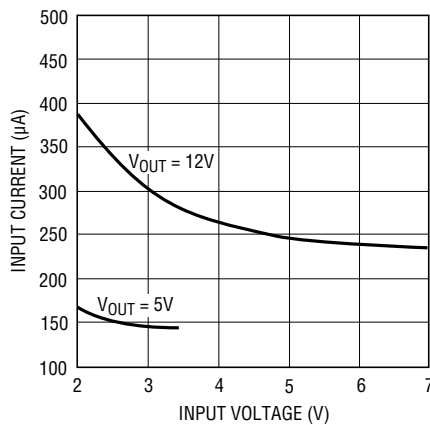

LT1301 G5

**Load Transient Response of Figure 1 Circuit**

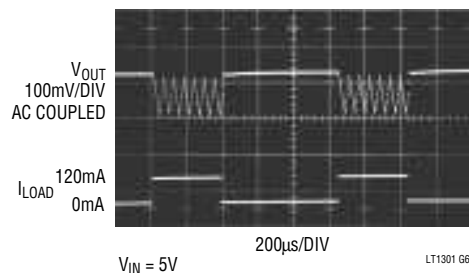

LT1301 G6

**Load Transient Response of Figure 1 Circuit**

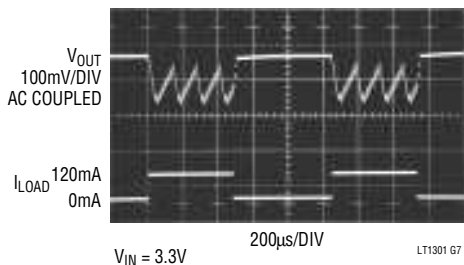

LT1301 G7

**Select Pin Transient Response**

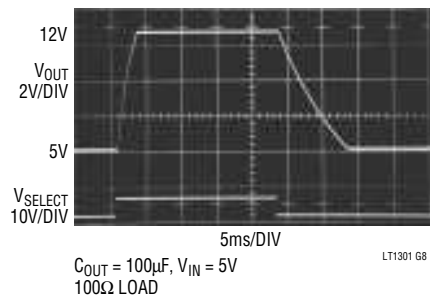

LT1301 G8

**Select Pin Transient Response**

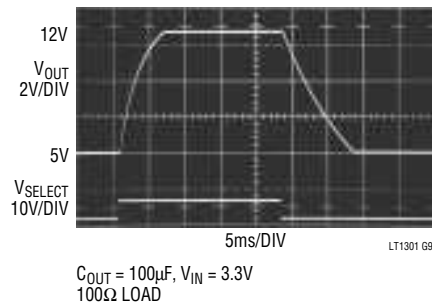

LT1301 G9

## PIN FUNCTIONS

**GND (Pin 1):** Signal Ground. Tie to PGND under the package.

**Sel (Pin 2):** Output Select. When tied to  $V_{IN}$  converter regulates at 12V. When grounded or floating converter regulates at 5V. May be driven under logic control.

**SHDN (Pin 3):** Shutdown. Pull high to shut down the LT1301. Ground for normal operation.

**Sense (Pin 4):** "Output" Pin. Goes to internal resistive divider. If operating at 5V output, a  $0.1\mu\text{F}$  ceramic capacitor is required from Sense to Ground.

**$I_{LIM}$  (Pin 5):** Float for 1A switch current limit. Tie to ground

for approximately 400mA. A resistor between  $I_{LIM}$  and ground sets peak current to some intermediate value .

**$V_{IN}$  (Pin 6):** Supply Pin. Must be bypassed with a large value electrolytic to ground. Keep bypass within 0.2" of the device.

**SW (Pin 7):** Switch Pin. Connect inductor and diode here. Keep layout short and direct to minimize radio frequency interference.

**PGND (Pin 8):** Power Ground. Tie to signal ground (pin 1) under the package. Bypass capacitor from  $V_{IN}$  should be tied directly to PGND within 0.2" of the device.

## BLOCK DIAGRAM

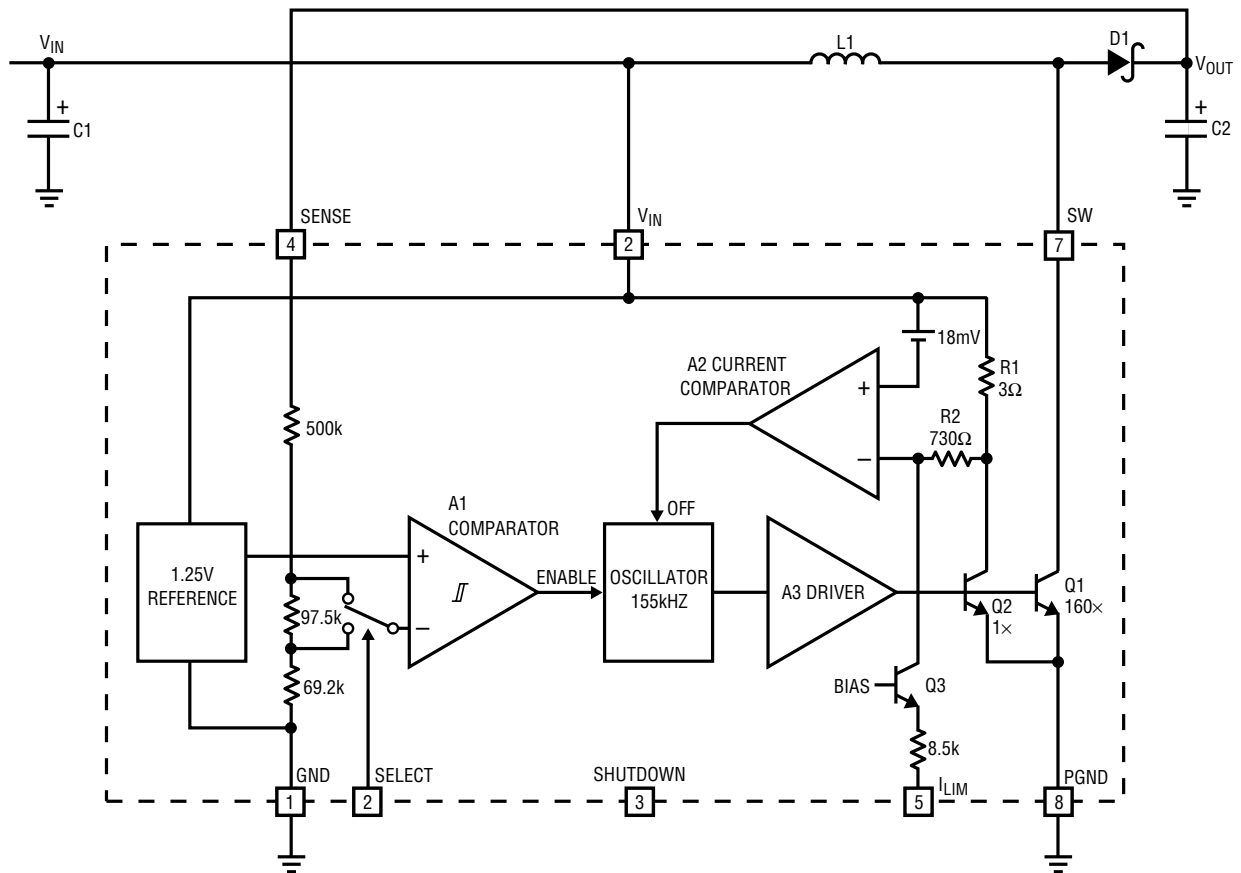
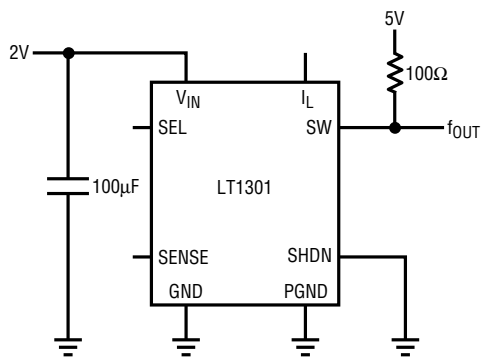

Figure 2.

LT1301 F2

## TEST CIRCUIT



Oscillator Test Circuit

LT1301 TC

## OPERATION

Operation of the LT1301 is best understood by referring to the Block Diagram in Figure 2. When A1's negative input, related to the Sense pin voltage by the appropriate resistor-divider ratio is higher than the 1.25V reference voltage, A1's output is low. A2, A3 and the oscillator are turned off, drawing no current. Only the reference and A1 consume current, typically 120µA. When A1's negative input drops below 1.25V, overcoming A1's 6mV hysteresis, A1's output goes high enabling the oscillator, current comparator A2, and driver A3. Quiescent current increases to 2mA as the device prepares for high current switching. Q1 then turns on in controlled saturation for (nominally) 5.3µs or until comparator A2 trips, whichever comes first. After a fixed off-time of (nominally) 1.2µs, Q1 turns on again. The LT1301's switching causes current to alternately build up in L1 and dump into output capacitor C2 via D1, increasing the output voltage. When the output is high enough to cause A1's output to go to low, switching action ceases. C2 is left to supply current to the load until V<sub>OUT</sub> decreases enough to force A1's output high, and the entire cycle repeats. Figure 4 details relevant waveforms. A1's cycling causes low-to-mid-frequency ripple voltage on the output. Ripple can be reduced by making the output capacitor large. The 33µF unit specified results in ripple of 100mV to 200mV on the 12V output. A 100µF capacitor will decrease ripple to 50mV. If operating at 5V output a 0.1µF ceramic capacitor is required at the Sense pin in addition to the electrolytic.

If switch current reaches 1A, causing A2 to trip, switch on-time is reduced and off-time increases slightly. This allows continuous mode operation during bursts. A2 monitors

the voltage across 3Ω resistor R1 which is directly related to the switch current. Q2's collector current is set by the emitter-area ratio to 0.6% of Q1's collector current. When R1's voltage drop exceeds 18mV, corresponding to 1A switch current, A2's output goes high, truncating the on-time portion of the oscillator cycle and increasing off-time to about 2µs as shown in Figure 3, trace A. This programmed peak current can be reduced by tying the I<sub>LIM</sub> pin to ground, causing 15µA to flow through R2 into Q3's collector. Q3's current causes a 10.4mV drop in R2 so that only an additional 7.6mV is required across R1 to turn off the switch. This corresponds to a 400mA switch current as shown in Figure 3, trace B. The reduced peak switch current reduces I<sup>2</sup>R losses in Q1, L1, C1 and D1. Efficiency can be increased by doing this provided that the accompanying reduction in full load current is acceptable. Lower peak currents also extend alkaline battery life due to the alkaline cell's high internal impedance.

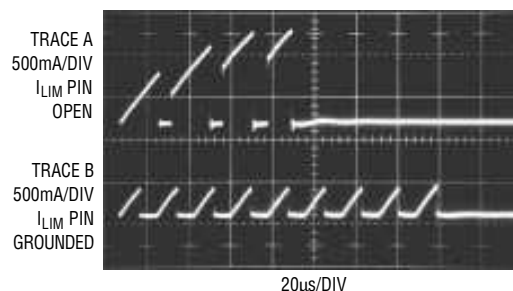

Figure 3. Switch Pin Current With I<sub>LIM</sub> Floating or Grounded

## APPLICATIONS INFORMATION

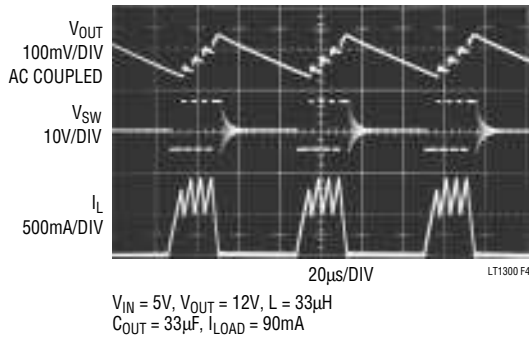

Figure 4. Burst Mode Operation in Action

### Output Voltage Selection

The LT1301 can be selected to 5V or 12V under logic control or fixed at either by tying Select to ground or  $V_{IN}$  respectively. It is permissible to tie Select to a voltage higher than  $V_{IN}$  as long as it does not exceed 10V. Efficiency in 5V mode will be slightly less than in 12V mode due to the fact that the diode drop is a greater percentage of 5V than 12V. Since the bipolar switch in the LT1301 gets its base drive from  $V_{IN}$ , no reduction in switch efficiency occurs when in 5V mode. When  $V_{IN}$  exceeds the programmed output voltage the output will follow the input. This is characteristic of the simple step-up or “boost” converter topology. A circuit example that provides a regulated output with an input voltage above or below the output (known as a buck-boost or SEPIC) is shown in the Typical Applications section.

### Shutdown

The converter can be turned off by pulling SHDN (pin 3) high. Quiescent current drops to 10µA in this condition. Bias current of 8µA to 10µA flows into the pin (at 5V input). It is recommended that SHDN not be left floating. Tie the pin to ground if the feature is not used. SHDN can be driven high even if  $V_{IN}$  is floating.

### $I_{LIM}$ Function

The LT1301’s current limit ( $I_{LIM}$ ) pin can be used for soft start. Upon start-up, the LT1301 will draw maximum current from the supply (about 1A) from the supply to charge the output capacitor. Figure 5 shows  $V_{OUT}$  and  $I_{IN}$  waveforms as the device is turned on. The high current flow can create IR drops along supply and ground lines or cause the input supply to drop out momentarily. By

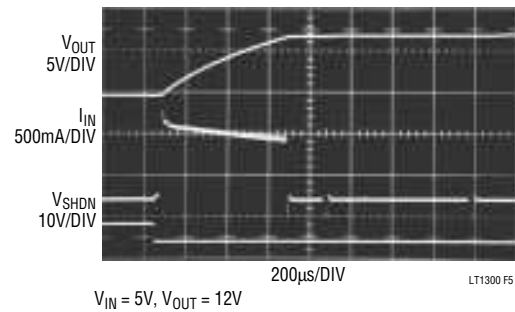

Figure 5. Start-Up Response

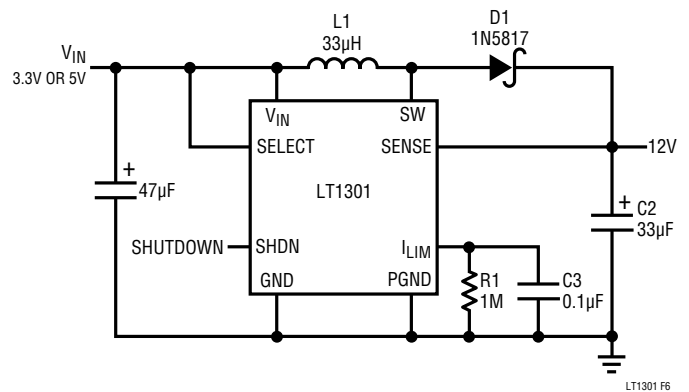

Figure 6.

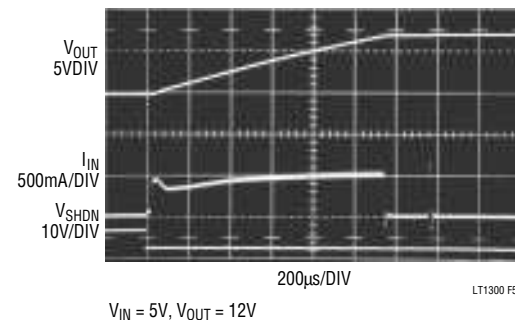

Figure 7. Startup Response Soft-Start Circuitry Added

adding R1 and C3 as shown in Figure 6, the switch current in the LT1301 is initially limited to 400mA until the 15µA flowing out of the  $I_{LIM}$  pin charges up C3. Input current is held to under 500mA while the output voltage ramps up to 12V as shown in Figure 7. R1 provides a discharge path for the capacitor without appreciably decreasing peak switch current. When using the  $I_{LIM}$  pin soft-start mode a minimum load of a few hundred microamperes is recommended to prevent C3 from discharging, as no current flows out of  $I_{LIM}$  when the LT1301 is not

## APPLICATIONS INFORMATION

**Table 1. Recommended Inductors**

PART NUMBER	VENDOR	L (μH)	DCR (Ω)	V <sub>IN</sub> (V)	I <sub>LIM</sub> PIN	EFFICIENCY (%)			COMPONENT HEIGHT (mm)	PHONE NUMBER
						30mA	60mA	120mA		
D03316-333	Coilcraft	33	0.088	3.3	Open	84	84	85	5.5	(708) 639-6400
				5	Open	89	89	90		
D01608-223	Coilcraft	22	.31	3.3	Open	82	82	—	3.5	
				3.3	Ground	85	—	—		
				5	10k	86	87	—		
				5	Ground	88	—	—		
D01608-103	Coilcraft	10	.11	2	Open	78	—	—	3.5	
CTX20-1	Coiltronics	20	.175	3.3	Open	84	84	—	4.2	(407) 241-7876
				5	Open	88	88	89		
GA10-332	Gowanda	33	.077	3.3	Open	86	86	87	Through-Hole	(716) 532-2234
				5	Open	89	89	90		
LQH3G220K04M00	Murata-Erie	22	0.7	3.3	Ground	81	—	—	2.0	(404) 436-1300
				5	Ground	85	—	—		
CD73-330KC	Sumida	33	0.131	3.3	Open	84	85	86	3.5	(708) 956-0666
				5	Open	88	88	89		
CDRH62-330MC	Sumida	33	0.48	3.3	Open	80	80	81	3.0	
					Ground	85	—	—		
				5	Open	84	84	85		
					Ground	83	—	—		

switching. Zero load current causes the LT1301 to switch so infrequently that C3 can completely discharge reducing subsequent peak switch current to 400mA. If a load is suddenly applied, output voltage will sag until C3 can be recharged and peak switch current returns to 1A.

If the full capacity of the LT1301 is not required peak current can be reduced by changing the value of R3 as shown in Figure 8. With R3 = 0 switch current is limited to approximately 400mA. Smaller, less expensive inductors with lower saturation ratings can then be used.

### Inductor Selection

For full output power, the inductor should have a saturation current rating of 1.25A for worst-case current limit, although it is acceptable to bias an inductor 20% or more into saturation. Smaller inductors can be used in conjunction with the I<sub>LIM</sub> pin. Efficiency is significantly affected by inductor DCR. For best efficiency limit the DCR to 0.03Ω or less. Toroidal types are preferred in some cases due to their inherent flux containment and EMI/RFI superiority. Recommended inductors are listed in Table 1.

**Table 2. Recommended Capacitors**

VENDOR	SERIES	TYPE	PHONE#
AVX	TPS	Surface Mount	(803)448-9411
Sanyo	OS-CON	Through-Hole	(619) 661-6835
Panasonic	HFQ	Through-Hole	(201) 348-5200

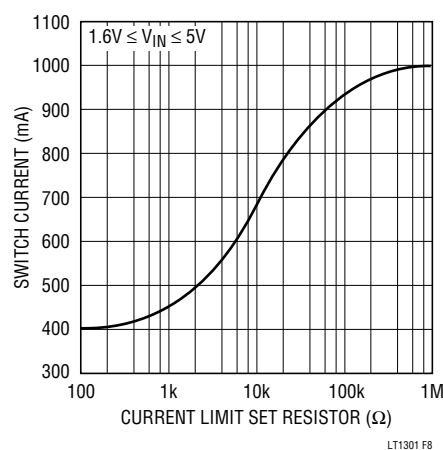

**Figure 8. Peak Switch Current vs. Current Limit Set Resistor**

## APPLICATIONS INFORMATION

### Capacitor Selection

Low ESR capacitors are required for both input and output of the LT1301. ESR directly affects ripple voltage and efficiency. For surface mount applications AVX TPS series tantalum capacitors are recommended. These have been specially designed for SMPS and have low ESR along with high surge current ratings. For through-hole applications Sanyo OS-CON capacitors offer extremely low ESR in a small size. Again, if peak switch current is reduced using the  $I_{LIM}$  pin, capacitor requirements can be relaxed and smaller, higher ESR units can be used. Suggested capacitor sources are listed in Table 2.

### Diode Selection

Best performance is obtained with a Schottky rectifier diode such as the 1N5817. Phillips Components makes this in surface mount as the PRL15817. Motorola makes the MBRS130LT3 which is slightly better and also in surface mount. For lower output power a 1N4148 can be used although efficiency will suffer substantially.

### Layout Considerations

The LT1301 is a high speed, high current device. The input capacitor must be no more than 0.2" from  $V_{IN}$  (pin 6) and ground. Connect the PGND and GND (pins 8 and 1) together under the package. Place the inductor adjacent to SW (pin 7) and make the switch pin trace as short as possible. This keeps radiated noise to a minimum.

## TYPICAL APPLICATIONS

Four-Cell to 5V Converter

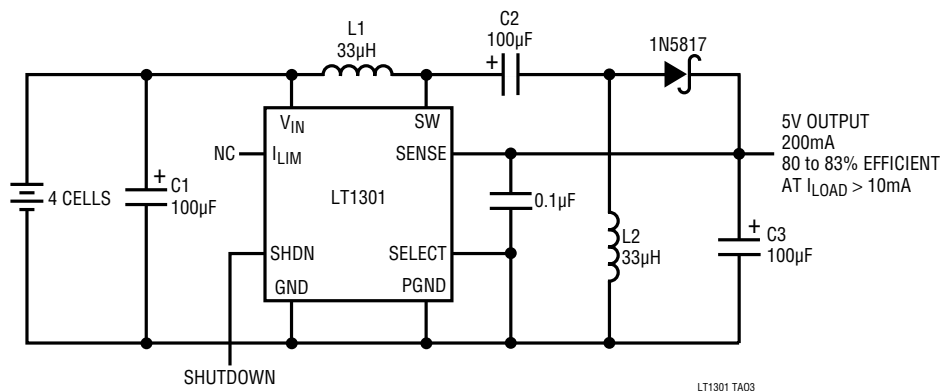

Step-Up Converter with Automatic Output Disconnect

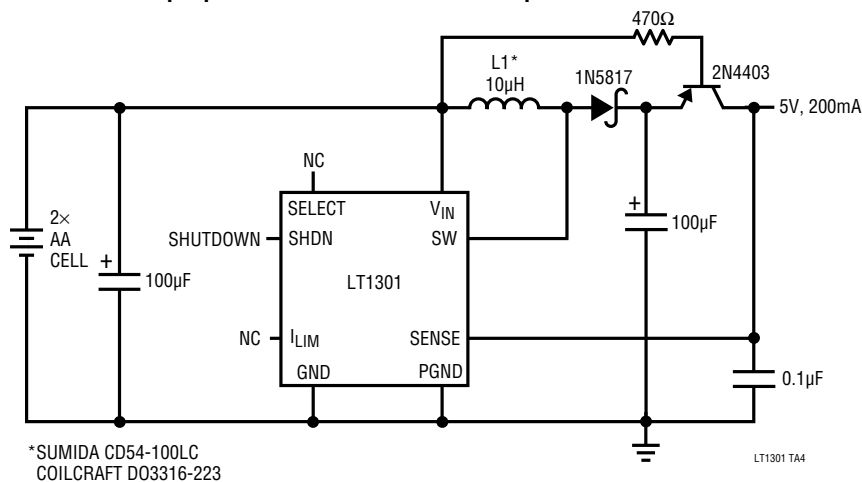

# TYPICAL APPLICATIONS

## LCD Contrast Supply

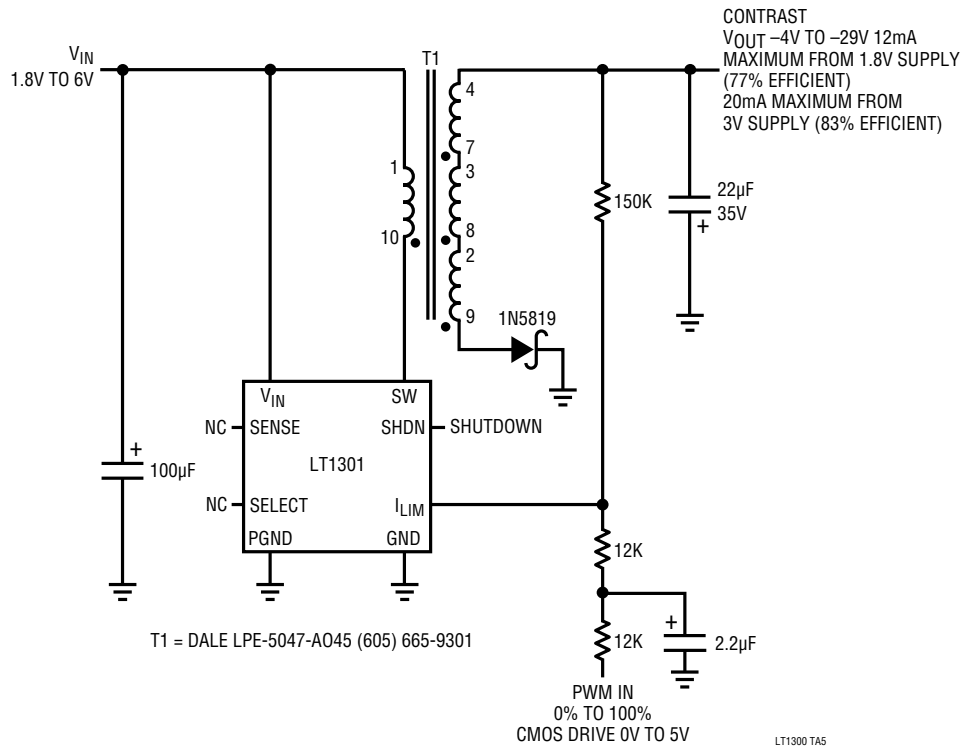

## Low-Voltage CCFL Power Supply

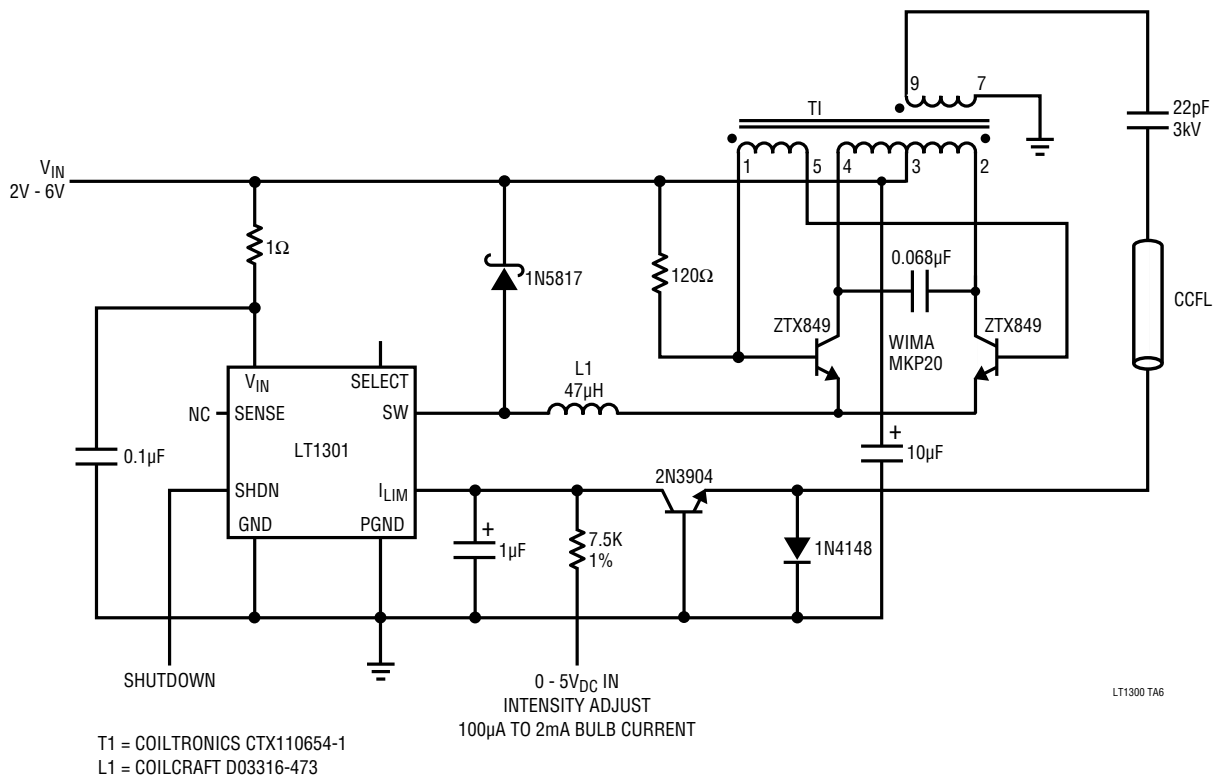

**TYPICAL APPLICATIONS**

**5V to -5V Converter**

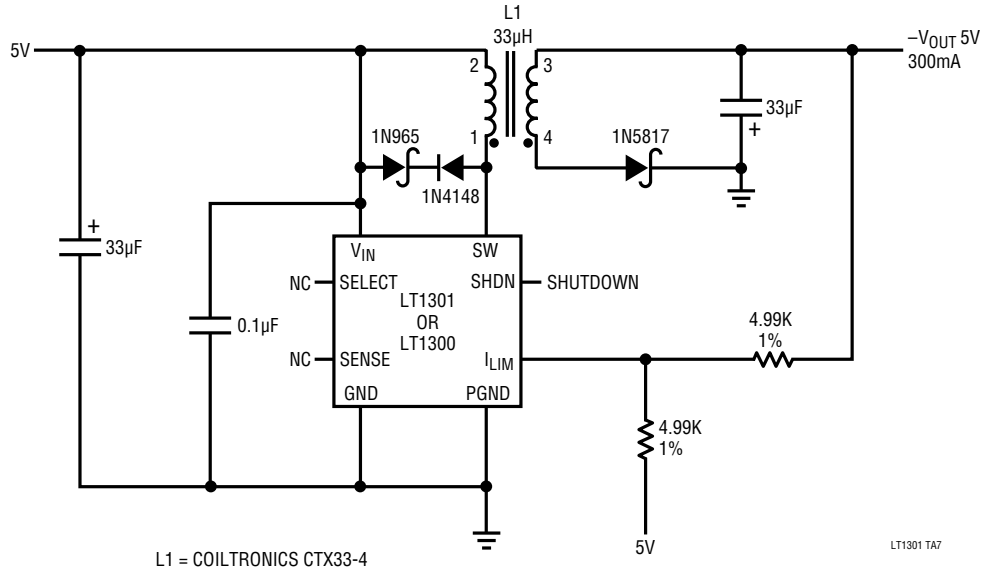

**PACKAGE DESCRIPTION** Dimensions in inches (millimeters) unless otherwise noted.

**N8 Package  
8-Lead Plastic DIP**

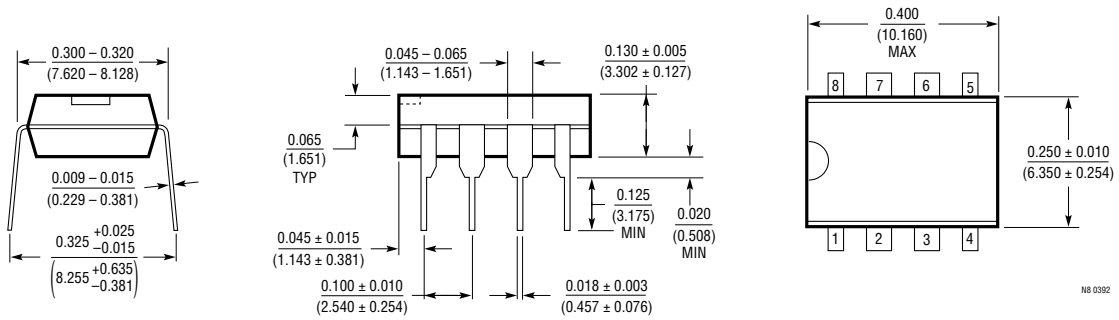

**S8 Package  
8-Lead Plastic SOIC**

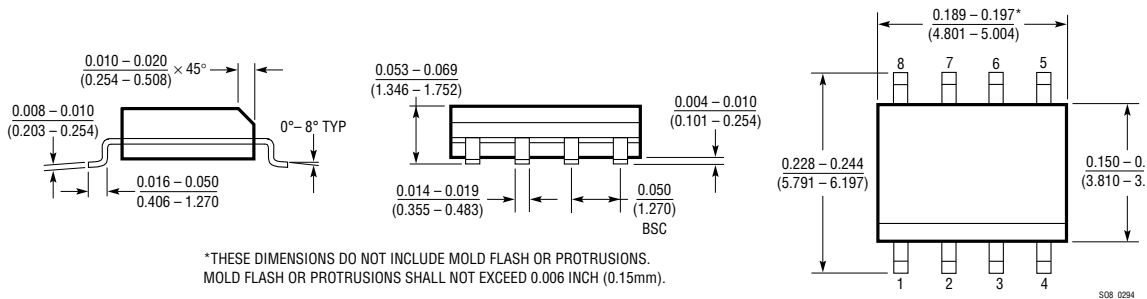

**U.S. Area Sales Offices**

**NORTHEAST REGION**

**Linear Technology Corporation**  
 One Oxford Valley  
 2300 E. Lincoln Hwy., Suite 306  
 Langhorne, PA 19047  
 Phone: (215) 757-8578  
 FAX: (215) 757-5631

**Linear Technology Corporation**

266 Lowell St., Suite B-8  
 Wilmington, MA 01887  
 Phone: (508) 658-3881  
 FAX: (508) 658-2701

**SOUTHEAST REGION**

**Linear Technology Corporation**  
 17060 Dallas Parkway  
 Suite 208  
 Dallas, TX 75248  
 Phone: (214) 733-3071  
 FAX: (214) 380-5138

**CENTRAL REGION**

**Linear Technology Corporation**  
 Chesapeake Square  
 229 Mitchell Court, Suite A-25  
 Addison, IL 60101  
 Phone: (708) 620-6910  
 FAX: (708) 620-6977

**SOUTHWEST REGION**

**Linear Technology Corporation**  
 22141 Ventura Blvd.  
 Suite 206  
 Woodland Hills, CA 91364  
 Phone: (818) 703-0835  
 FAX: (818) 703-0517

**NORTHWEST REGION**

**Linear Technology Corporation**  
 782 Sycamore Dr.  
 Milpitas, CA 95035  
 Phone: (408) 428-2050  
 FAX: (408) 432-6331

**International Sales Offices**

**FRANCE**

**Linear Technology S.A.R.L.**  
 Immeuble "Le Quartz"  
 58 Chemin de la Justice  
 92290 Chatenay Malabry  
 France  
 Phone: 33-1-41079555  
 FAX: 33-1-46314613

**GERMANY**

**Linear Technology GmbH**  
 Untere Hauptstr. 9  
 D-85386 Eching  
 Germany  
 Phone: 49-89-3197410  
 FAX: 49-89-3194821

**JAPAN**

**Linear Technology KK**  
 5F YZ Bldg.  
 4-4-12 Iidabashi, Chiyoda-Ku  
 Tokyo, 102 Japan  
 Phone: 81-3-3237-7891  
 FAX: 81-3-3237-8010

**KOREA**

**Linear Technology Korea Branch**  
 Namsong Building, #505  
 Itaewon-Dong 260-199  
 Yongsan-Ku, Seoul  
 Korea  
 Phone: 82-2-792-1617  
 FAX: 82-2-792-1619

**SINGAPORE**

**Linear Technology Pte. Ltd.**  
 101 Boon Keng Road  
 #02-15 Kallang Ind. Estates  
 Singapore 1233  
 Phone: 65-293-5322  
 FAX: 65-292-0398

**TAIWAN**

**Linear Technology Corporation**  
 Rm. 801, No. 46, Sec. 2  
 Chung Shan N. Rd.  
 Taipei, Taiwan, R.O.C.  
 Phone: 886-2-521-7575  
 FAX: 886-2-562-2285

**UNITED KINGDOM**

**Linear Technology (UK) Ltd.**  
 The Coliseum, Riverside Way  
 Camberley, Surrey GU15 3YL  
 United Kingdom  
 Phone: 44-276-677676  
 FAX: 44-276-64851

**World Headquarters**

**Linear Technology Corporation**  
 1630 McCarthy Blvd.  
 Milpitas, CA 95035-7487  
 Phone: (408) 432-1900  
 FAX: (408) 434-0507

08/16/93