

Micropower DC/DC Converter

Adjustable and Fixed 5V, 12V

FEATURES

- Operates at Supply Voltages from 2V to 30V
- Works with Surface Mount Inductors
- 72kHz Oscillator
- Only Three External Components Required
- Step-Up or Step-Down Mode
- Low-Battery Detector Comparator On-Chip
- User Adjustable Current Limit
- Internal 1A Power Switch
- Fixed or Adjustable Output Voltage Versions
- Space Saving 8-Pin MiniDIP or SO-8 Package

APPLICATIONS

- 3V to 5V, 5V to 12V Converters
- 9V to 5V, 12V to 5V Converters
- Remote Controls
- Peripherals and Add-On Cards
- Battery Backup Supplies
- Uninterruptible Supplies
- Laptop and Palmtop Computers
- Cellular Telephones
- Portable Instruments
- Flash Memory VPP Generators

DESCRIPTION

The LT[®]1111 is a versatile micropower DC/DC converter. The device requires only three external components to deliver a fixed output of 5V or 12V. Supply voltage ranges from 2V to 12V in step-up mode and to 30V in step-down mode. The LT1111 functions equally well in step-up, step-down, or inverting applications.

The LT1111 oscillator is set at 72kHz, optimizing the device to work with off-the-shelf surface mount inductors. The device can deliver 5V at 100mA from a 3V input in step-up mode or 5V at 200mA from a 12V input in step-down mode.

Switch current limit can be programmed with a single resistor. An auxiliary open-collector gain block can be configured as a low-battery detector, linear post regulator, undervoltage lock-out circuit, or error amplifier.

For input sources of less than 2V use the LT1110.

LT, LTC and LT are registered trademarks of Linear Technology Corporation

TYPICAL APPLICATION

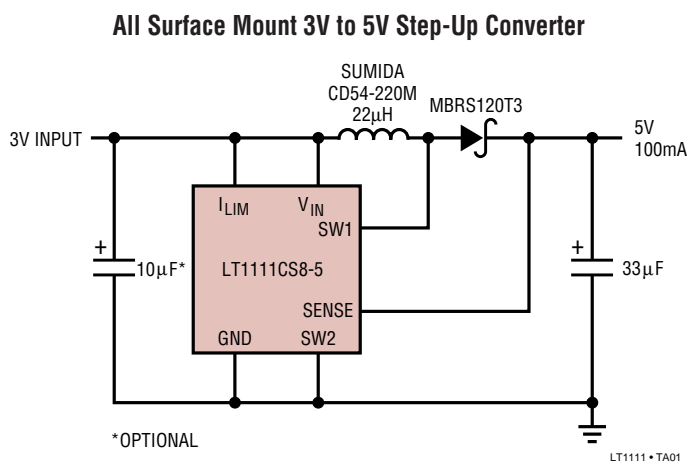

Typical Load Regulation

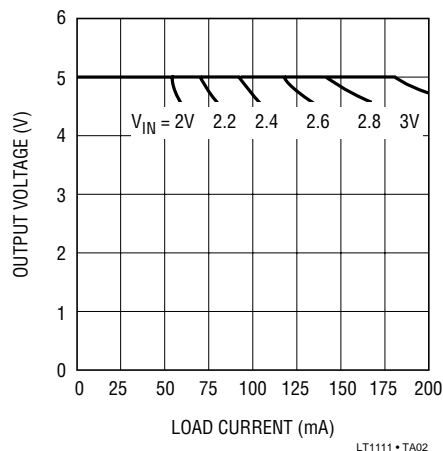

ABSOLUTE MAXIMUM RATINGS (Note 1)

Supply Voltage (V_{IN})	36V	Operating Temperature Range	
SW1 Pin Voltage (V_{SW1})	50V	LT1111C	0°C to 70°C
SW2 Pin Voltage (V_{SW2})	-0.5V to V_{IN}	LT1111I	-40°C to 105°C
Feedback Pin Voltage (LT1111)	5.5V	LT1111M (OBSOLETE)	-55°C to 125°C
Switch Current	1.5A	Storage Temperature Range	-65°C to 150°C
Maximum Power Dissipation	500mW	Lead Temperature (Soldering, 10 sec)	300°C

PACKAGE/ORDER INFORMATION

<p>N8 PACKAGE 8-LEAD PLASTIC DIP *FIXED VERSIONS $T_{JMAX} = 90^{\circ}C, \theta_{JA} = 130^{\circ}C/W (N)$</p>	ORDER PART NUMBER	<p>S8 PACKAGE 8-LEAD PLASTIC SO *FIXED VERSION $T_{JMAX} = 90^{\circ}C, \theta_{JA} = 150^{\circ}C/W$</p>	ORDER PART NUMBER
	LT1111CN8 LT1111CN8-5 LT1111CN8-12		LT1111CS8 LT1111CS8-5 LT1111CS8-12 LT1111IS8
J8 PACKAGE 8-LEAD CERAMIC DIP $T_{JMAX} = 150^{\circ}C, \theta_{JA} = 120^{\circ}C/W (J)$	LT1111MJ8 LT1111MJ8-5 LT1111MJ8-12	S8 PART MARKING	
OBSOLETE PACKAGE Consider the N8 Package for Alternate Source		1111 11115 11111 11111	

Consult LTC Marketing for parts specified with wider operating temperature ranges.

ELECTRICAL CHARACTERISTICS

The ● denotes the specifications which apply over the full operating temperature range, otherwise specifications are at $T_A = 25^{\circ}C, V_{IN} = 3V$, Military or Commercial Version

SYMBOL	PARAMETER	CONDITIONS	MIN	TYP	MAX	UNITS
I_Q	Quiescent Current	Switch OFF		300	400	μA
V_{IN}	Input Voltage	Step-Up Mode	● 2.0		12.6	V
		Step-Down Mode	●		30.0	V
	Comparator Trip Point Voltage	LT1111 (Note 2)	● 1.20	1.25	1.30	V
V_{OUT}	Output Sense Voltage	LT1111-5 (Note 3)	● 4.75	5.00	5.25	V
		LT1111-12 (Note 3)	● 11.40	12.00	12.60	V
	Comparator Hysteresis	LT1111	●	8	12.5	mV
	Output Hysteresis	LT1111-5	●	32	50	mV
		LT1111-12	●	75	120	mV
f_{OSC}	Oscillator Frequency		54	72	88	kHz
DC	Duty Cycle: Step-Up Mode	Full Load	43	50	59	%
	Step-Down Mode		24	34	50	%
t_{ON}	Switch ON Time: Step-Up Mode	I_{LIM} Tied to V_{IN}	5	7	9	μs
	Step-Down Mode	$V_{OUT} = 5V, V_{IN} = 12V$	3.3	5	7.8	μs
V_{SAT}	SW Saturation Voltage, Step-Up Mode	$V_{IN} = 3.0V, I_{SW} = 650mA$		0.5	0.65	V
		$V_{IN} = 5.0V, I_{SW} = 1A$		0.8	1.0	V
	SW Saturation Voltage, Step-Down Mode	$V_{IN} = 12V, I_{SW} = 650mA$		1.1	1.5	V

ELECTRICAL CHARACTERISTICS The ● denotes the specifications which apply over the full operating temperature range, otherwise specifications are at $T_A = 25^\circ\text{C}$. $V_{IN} = 3\text{V}$, Military or Commercial Version

SYMBOL	PARAMETER	CONDITIONS		MIN	TYP	MAX	UNITS
I_{FB}	Feedback Pin Bias Current	LT1111, $V_{FB} = 0\text{V}$	●		70	120	nA
I_{SET}	Set Pin Bias Current	$V_{SET} = V_{REF}$	●		70	300	nA
V_{OL}	Gain Block Output Low	$I_{SINK} = 300\mu\text{A}$, $V_{SET} = 1.00\text{V}$	●		0.15	0.4	V
	Reference Line Regulation	$5\text{V} \leq V_{IN} \leq 30\text{V}$ $2\text{V} \leq V_{IN} \leq 5\text{V}$	●		0.02 0.20	0.075 0.400	%/V %/V
A_V	Gain Block Gain	$R_L = 100\text{k}$ (Note 4)	●	1000	6000		V/V
I_{LIM}	Current Limit	220Ω from I_{LIM} to V_{IN}			400		mA
	Current Limit Temperature Coefficient		●		-0.3		%/°C
	Switch OFF Leakage Current	Measured at SW1 Pin, $V_{SW1} = 12\text{V}$			1	10	μA
	Maximum Excursion Below GND	$I_{SW1} \leq 10\mu\text{A}$, Switch OFF			-400	-350	mV

The ● denotes the specifications which apply over the full operating temperature range, otherwise specifications are at $T_A = 25^\circ\text{C}$. $V_{IN} = 3\text{V}$, $0^\circ\text{C} \leq T_A \leq 70^\circ\text{C}$ unless otherwise noted.

SYMBOL	PARAMETER	CONDITIONS		LT1111C			UNITS
				MIN	TYP	MAX	
I_Q	Quiescent Current	Switch OFF	●	300		450	μA
f_{OSC}	Oscillator Frequency		●	54	72	95	kH
DC	Duty Cycle: Step-Up Mode Step-Down Mode	Full Load	●	43	50	59	%
			●	24	34	50	%
t_{ON}	Switch ON Time: Step-Up Mode Step-Down Mode	I_{LIM} Tied to V_{IN} $V_{OUT} = 5\text{V}$, $V_{IN} = 12\text{V}$	●	5.0	7	9.0	μs
			●	3.3	5	7.8	μs
	Reference Line Regulation	$2\text{V} \leq V_{IN} \leq 5\text{V}$	●		0.2	0.7	%/V
V_{SAT}	SW Saturation Voltage, Step-Up Mode SW Saturation Voltage, Step-Down Mode	$V_{IN} = 3\text{V}$, $I_{SW} = 650\text{mA}$ $V_{IN} = 12\text{V}$, $I_{SW} = 650\text{mA}$	●		0.5	0.65	V
			●		1.1	1.50	V

Note 1: Absolute Maximum Ratings are those values beyond which the life of a device may be impaired.

Note 2: This specification guarantees that both the high and low trip points of the comparator fall within the 1.20V to 1.30V range.

Note 3: The output voltage waveform will exhibit a sawtooth shape due to the comparator hysteresis. The output voltage on the fixed output versions will always be within the specified range.

Note 4: 100k resistor connected between a 5V source and the A0 pin.

TYPICAL PERFORMANCE CHARACTERISTICS

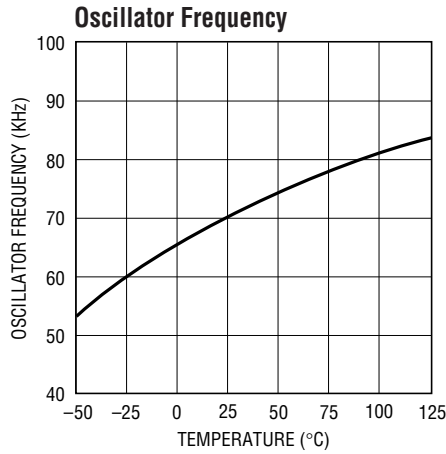

LT1111 • TPC01

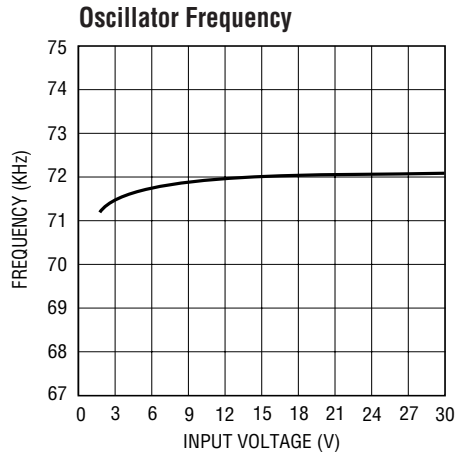

LT1111 • TPC02

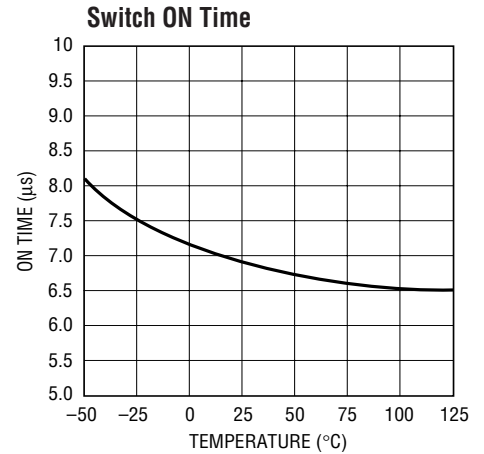

LT1111 • TPC03

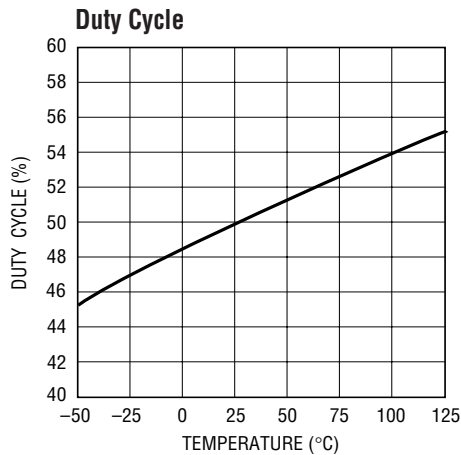

LT1111 • TPC04

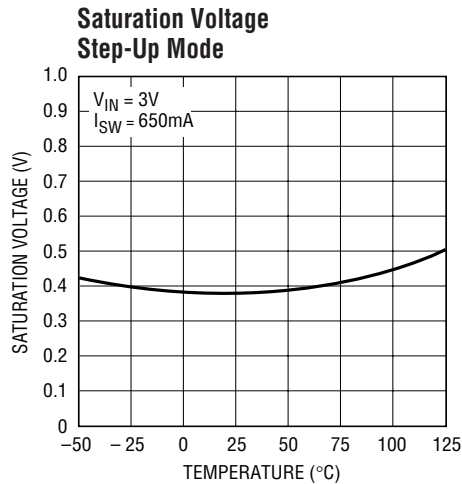

LT1111 • TPC05

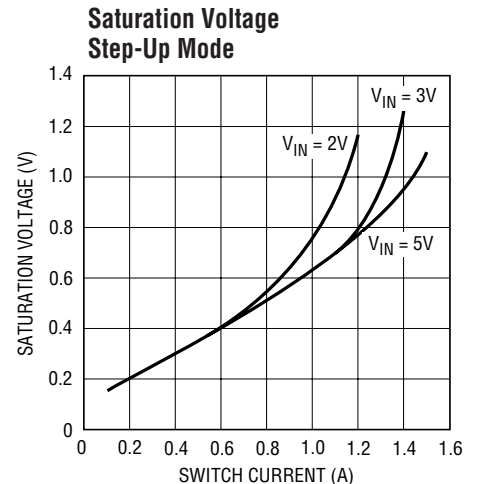

LT1111 • TPC06

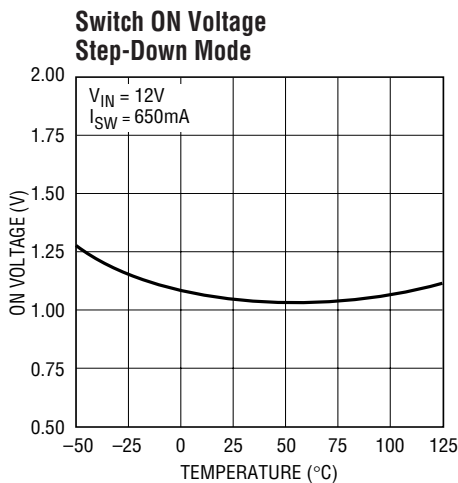

LT1111 • TPC07

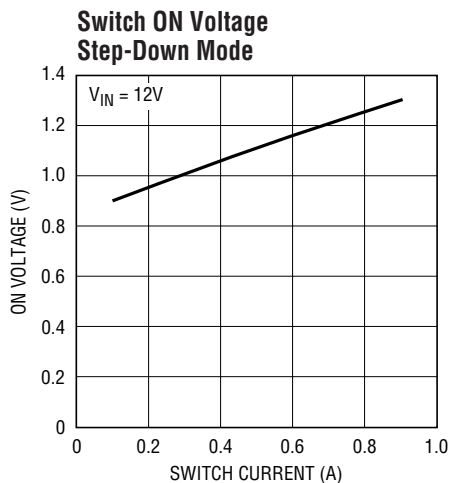

LT1111 • TPC08

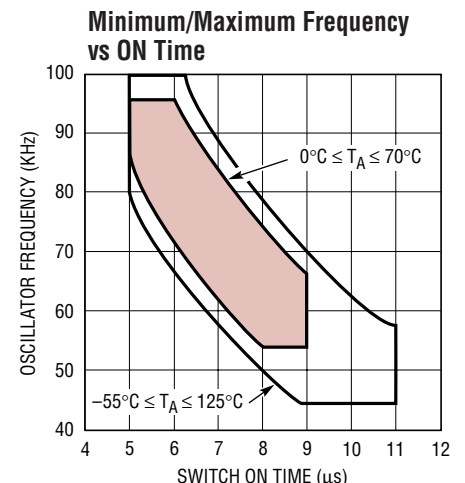

LT1111 • TPC09

TYPICAL PERFORMANCE CHARACTERISTICS

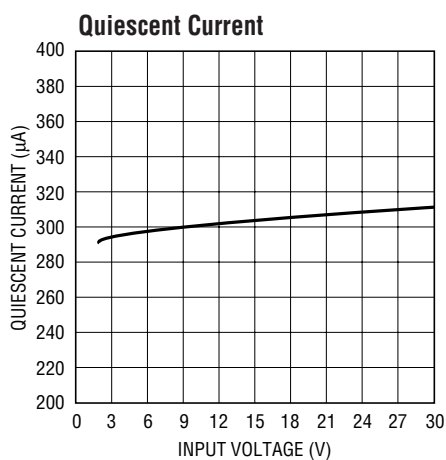

LT1111 • TPC10

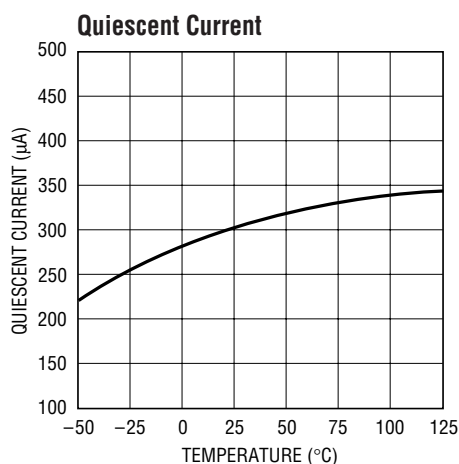

LT1111 • TPC11

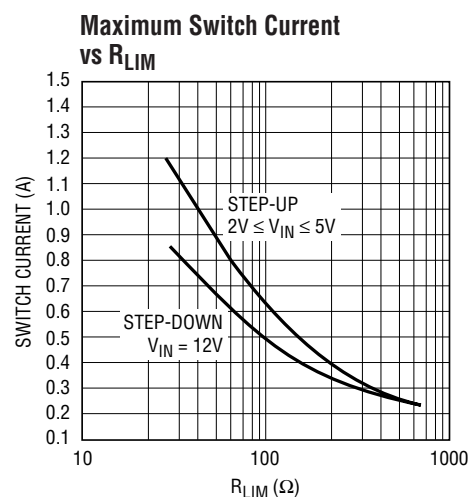

LT1111 • TPC12

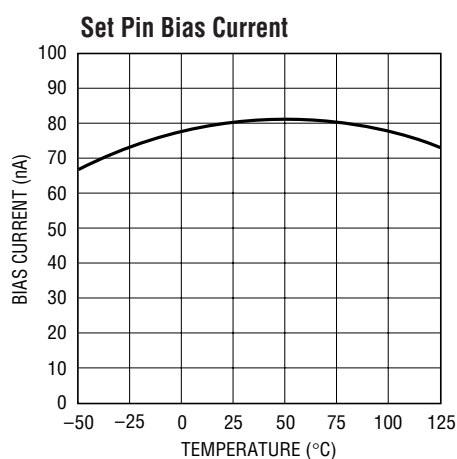

LT1111 • TPC13

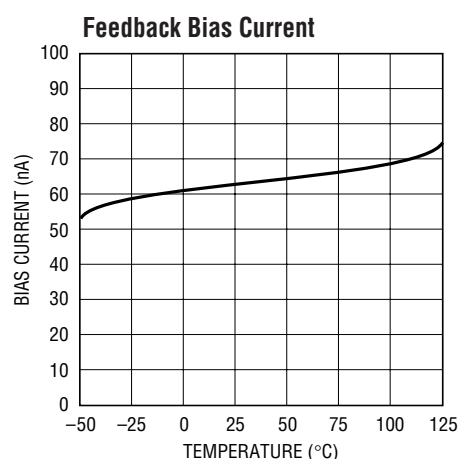

LT1111 • TPC14

PIN FUNCTIONS

I_{LIM} (Pin 1): Connect this pin to V_{IN} for normal use. Where lower current limit is desired, connect a resistor between I_{LIM} and V_{IN} . A 220Ω resistor will limit the switch current to approximately 400mA.

V_{IN} (Pin 2): Input Supply Voltage.

SW1 (Pin 3): Collector of Power Transistor. For step-up mode connect to inductor/diode. For step-down mode connect to V_{IN} .

SW2 (Pin 4): Emitter of Power Transistor. For step-up mode connect to ground. For step-down mode connect to inductor/diode. This pin must never be allowed to go more than a Schottky diode drop below ground.

GND (Pin 5): Ground.

AO (Pin 6): Auxiliary Gain Block (GB) Output. Open collector, can sink $300\mu\text{A}$.

SET (Pin 7): GB Input. GB is an op amp with positive input connected to SET pin and negative input connected to 1.25V reference.

FB/SENSE (Pin 8): On the LT1111 (adjustable) this pin goes to the comparator input. On the LT1111-5 and LT1111-12, this pin goes to the internal application resistor that sets output voltage.

BLOCK DIAGRAMS

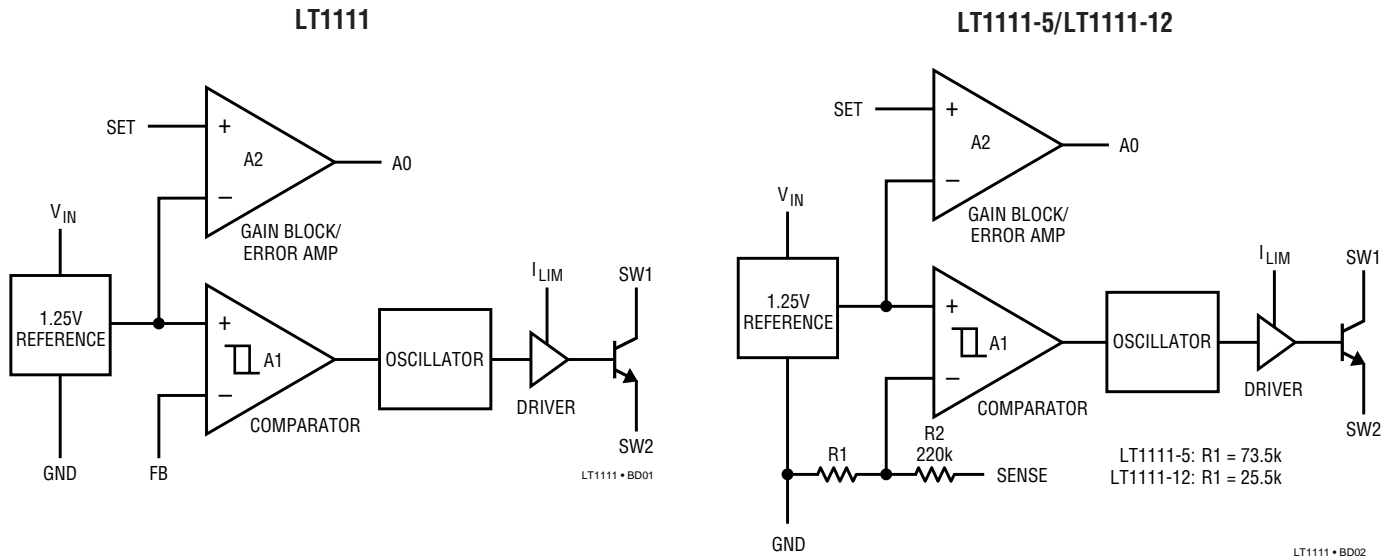

OPERATION

The LT1111 is a gated oscillator switcher. This type architecture has very low supply current because the switch is cycled when the feedback pin voltage drops below the reference voltage. Circuit operation can best be understood by referring to the LT1111 block diagram. Comparator A1 compares the feedback (FB) pin voltage with the 1.25V reference signal. When FB drops below 1.25V, A1 switches on the 72kHz oscillator. The driver amplifier boosts the signal level to drive the output NPN power switch. The switch cycling action raises the output voltage and FB pin voltage. When the FB voltage is sufficient to trip A1, the oscillator is gated off. A small amount of hysteresis built into A1 ensures loop stability without external frequency compensation. When the comparator output is low, the oscillator and all high current circuitry is turned off, lowering device quiescent current to just 300 μ A.

The oscillator is set internally for 7 μ s ON time and 7 μ s OFF time, optimizing the device for circuits where V_{OUT} and V_{IN} differ by roughly a factor of 2. Examples include a 3V to 5V step-up converter or a 9V to 5V step-down converter.

Gain block A2 can serve as a low-battery detector. The negative input of A2 is the 1.25V reference. A resistor divider from V_{IN} to GND, with the mid-point connected to the SET pin provides the trip voltage in a low-battery detector application. A0 can sink 300 μ A (use a 22k resistor pull-up to 5V).

A resistor connected between the I_{LIM} pin and V_{IN} sets maximum switch current. When the switch current exceeds the set value, the switch cycle is prematurely terminated. If current limit is not used, I_{LIM} should be tied directly to V_{IN} . Propagation delay through the current limit circuitry is approximately 1 μ s.

In step-up mode the switch emitter (SW2) is connected to ground and the switch collector (SW1) drives the inductor; in step-down mode the collector is connected to V_{IN} and the emitter drives the inductor.

The LT1111-5 and LT1111-12 are functionally identical to the LT1111. The -5 and -12 versions have on-chip voltage setting resistors for fixed 5V or 12V outputs. Pin 8 on the fixed versions should be connected to the output. No external resistors are needed.

APPLICATIONS INFORMATION

Inductor Selection — General

A DC/DC converter operates by storing energy as magnetic flux in an inductor core, and then switching this energy into the load. Since it is flux, not charge, that is stored, the output voltage can be higher, lower, or opposite in polarity to the input voltage by choosing an appropriate switching topology. To operate as an efficient energy transfer element, the inductor must fulfill three requirements. First, the inductance must be low enough for the inductor to store adequate energy under the worst case condition of minimum input voltage and switch-on time. The inductance must also be high enough so maximum current ratings of the LT1111 and inductor are not exceeded at the other worst case condition of maximum input voltage and ON time. Additionally, the inductor core must be able to store the required flux; i.e., it must not saturate. At power levels generally encountered with LT1111 based designs, small surface mount ferrite core units with saturation current ratings in the 300mA to 1A range and DCR less than 0.4Ω (depending on application) are adequate. Lastly, the inductor must have sufficiently low DC resistance so excessive power is not lost as heat in the windings. An additional consideration is Electro-Magnetic Interference (EMI). Toroid and pot core type inductors are recommended in applications where EMI must be kept to a minimum; for example, where there are sensitive analog circuitry or transducers nearby. Rod core types are a less expensive choice where EMI is not a problem. Minimum and maximum input voltage, output voltage and output current must be established before an inductor can be selected.

Inductor Selection — Step-Up Converter

In a step-up, or boost converter (Figure 4), power generated by the inductor makes up the difference between input and output. Power required from the inductor is determined by:

$$P_L = (V_{OUT} + V_D - V_{IN\ MIN}) (I_{OUT}) \quad (1)$$

where V_D is the diode drop (0.5V for a 1N5818 Schottky). Energy required by the inductor per cycle must be equal or greater than:

$$P_L / f_{OSC} \quad (2)$$

in order for the converter to regulate the output.

When the switch is closed, current in the inductor builds according to:

$$I_L(t) = \frac{V_{IN}}{R'} \left(1 - e^{-\frac{R't}{L}} \right) \quad (3)$$

where R' is the sum of the switch equivalent resistance (0.8Ω typical at 25°C) and the inductor DC resistance. When the drop across the switch is small compared to V_{IN} , the simple lossless equation:

$$I_L(t) = \frac{V_{IN}}{L} t \quad (4)$$

can be used. These equations assume that at $t = 0$, inductor current is zero. This situation is called “discontinuous mode operation” in switching regulator parlance. Setting “t” to the switch-on time from the LT1111 specification table (typically 7μs) will yield I_{PEAK} for a specific “L” and V_{IN} . Once I_{PEAK} is known, energy in the inductor at the end of the switch-on time can be calculated as:

$$E_L = \frac{1}{2} L I_{PEAK}^2 \quad (5)$$

E_L must be greater than P_L/f_{OSC} for the converter to deliver the required power. For best efficiency I_{PEAK} should be kept to 1A or less. Higher switch currents will cause excessive drop across the switch resulting in reduced efficiency. In general, switch current should be held to as low a value as possible in order to keep switch, diode and inductor losses at a minimum.

As an example, suppose 12V at 60mA is to be generated from a 4.5V to 8V input. Recalling equation (1),

$$P_L = (12V + 0.5V - 4.5V)(60mA) = 480mW \quad (6)$$

Energy required from the inductor is

$$\frac{P_L}{f_{OSC}} = \frac{480mW}{72kHz} = 6.7\mu J \quad (7)$$

APPLICATIONS INFORMATION

Picking an inductor value of 47μH with 0.2Ω DCR results in a peak switch current of:

$$I_{PEAK} = \frac{4.5V}{1.0\Omega} \left(1 - e^{\frac{-1.0\Omega \cdot 7\mu s}{47\mu H}} \right) = 623mA. \quad (8)$$

Substituting I_{PEAK} into Equation 4 results in:

$$E_L = \frac{1}{2} (47\mu H) (0.623A)^2 = 9.1\mu J \quad (9)$$

Since 9.1μJ > 6.7μJ, the 47μH inductor will work. This trial-and-error approach can be used to select the optimum inductor. Keep in mind the switch current maximum rating of 1.5A. If the calculated peak current exceeds this, consider using the LT1110. The 70% duty cycle of the LT1110 allows more energy per cycle to be stored in the inductor, resulting in more output power.

A resistor can be added in series with the I_{LIM} pin to invoke switch current limit. The resistor should be picked so the calculated I_{PEAK} at minimum V_{IN} is equal to the Maximum Switch Current (from Typical Performance Characteristic curves). Then, as V_{IN} increases, switch current is held constant, resulting in increasing efficiency.

Inductor Selection — Step-Down Converter

The step-down case (Figure 5) differs from the step-up in that the inductor current flows through the load during both the charge and discharge periods of the inductor. Current through the switch should be limited to ~650mA in this mode. Higher current can be obtained by using an external switch (see Figure 6). The I_{LIM} pin is the key to successful operation over varying inputs.

After establishing output voltage, output current and input voltage range, peak switch current can be calculated by the formula:

$$I_{PEAK} = \frac{2I_{OUT}}{DC} \left[\frac{V_{OUT} + V_D}{V_{IN} - V_{SW} + V_D} \right] \quad (10)$$

where DC = duty cycle (0.50)

V_{SW} = switch drop in step-down mode

V_D = diode drop (0.5V for a 1N5818)

I_{OUT} = output current

V_{OUT} = output voltage

V_{IN} = minimum input voltage

V_{SW} is actually a function of switch current which is in turn a function of V_{IN} , L, time, and V_{OUT} . To simplify, 1.5V can be used for V_{SW} as a very conservative value.

Once I_{PEAK} is known, inductor value can be derived from:

$$L = \frac{V_{IN\ MIN} - V_{SW} - V_{OUT}}{I_{PEAK}} \cdot t_{ON} \quad (11)$$

where t_{ON} = switch-on time (7μs).

Next, the current limit resistor R_{LIM} is selected to give I_{PEAK} from the R_{LIM} Step-Down Mode curve. The addition of this resistor keeps maximum switch current constant as the input voltage is increased.

As an example, suppose 5V at 300mA is to be generated from a 12V to 24V input. Recalling Equation (10),

$$I_{PEAK} = \frac{2(300mA)}{0.50} \left[\frac{5 + 0.5}{12 - 1.5 + 0.5} \right] = 600mA \quad (12)$$

Next, inductor value is calculated using Equation (11):

$$L = \frac{12 - 1.5 - 5}{600mA} 7\mu s = 64\mu H. \quad (13)$$

Use the next lowest standard value (56μH).

Then pick R_{LIM} from the curve. For $I_{PEAK} = 600mA$, $R_{LIM} = 56\Omega$.

Inductor Selection — Positive-to-Negative Converter

Figure 7 shows hookup for positive-to-negative conversion. All of the output power must come from the inductor. In this case,

$$P_L = (|V_{OUT}| + V_D)(I_{OUT}) \quad (14)$$

In this mode the switch is arranged in common collector or step-down mode. The switch drop can be modeled as a 0.75V source in series with a 0.65Ω resistor. When the

APPLICATIONS INFORMATION

switch closes, current in the inductor builds according to

$$I_L(t) = \frac{V_L}{R'} \left(1 - e^{-\frac{R't}{L}} \right) \quad (15)$$

where $R' = 0.65\Omega + DCR_L$
 $V_L = V_{IN} - 0.75V$

As an example, suppose $-5V$ at $50mA$ is to be generated from a $4.5V$ to $5.5V$ input. Recalling Equation (14),

$$P_L = (|-5V| + 0.5V)(50mA) = 275mW \quad (16)$$

Energy required from the inductor is:

$$\frac{P_L}{f_{osc}} = \frac{275mW}{72kHz} = 3.8\mu J. \quad (17)$$

Picking an inductor value of $56\mu H$ with 0.2Ω DCR results in a peak switch current of:

$$I_{PEAK} = \frac{(4.5V - 0.75V)}{(0.65\Omega + 0.2\Omega)} \left(1 - e^{-\frac{-0.85\Omega \times 7\mu s}{56\mu H}} \right) = 445mA. \quad (18)$$

Substituting I_{PEAK} into Equation (4) results in:

$$E_L = \frac{1}{2} (56\mu H) (0.445A)^2 = 5.54\mu J. \quad (19)$$

Since $5.54\mu J > 3.82\mu J$, the $56\mu H$ inductor will work.

With this relatively small input range, R_{LIM} is not usually necessary and the I_{LIM} pin can be tied directly to V_{IN} . As in the step-down case, peak switch current should be limited to $\sim 650mA$.

Capacitor Selection

Selecting the right output capacitor is almost as important as selecting the right inductor. A poor choice for a filter capacitor can result in poor efficiency and/or high output ripple. Ordinary aluminum electrolytics, while inexpensive and readily available, may have unacceptably poor equivalent series resistance (ESR) and ESL (inductance). There are low ESR aluminum capacitors on the market

specifically designed for switch mode DC/DC converters which work much better than general-purpose units. Tantalum capacitors provide still better performance at more expense. We recommend OS-CON capacitors from Sanyo Corporation (San Diego, CA). These units are physically quite small and have extremely low ESR. To illustrate, Figures 1, 2, and 3 show the output voltage of an LT1111 based converter with three $100\mu F$ capacitors. The peak switch current is $500mA$ in all cases. Figure 1 shows a Sprague 501D, 25V aluminum capacitor. V_{OUT} jumps by over $120mV$ when the switch turns off, followed by a drop in voltage as the inductor dumps into the capacitor. This works out to be an ESR of over 0.24Ω . Figure 2 shows the same circuit, but with a Sprague 150D, 20V tantalum capacitor replacing the aluminum unit. Output jump is now about $35mV$, corresponding to an ESR of 0.07Ω . Figure 3 shows the circuit with a 16V OS-CON unit. ESR is now only 0.02Ω .

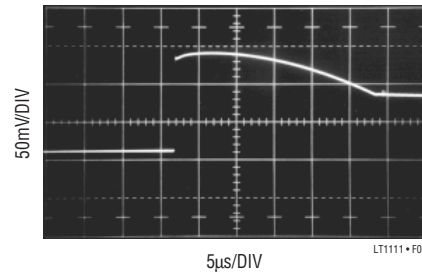

Figure 1. Aluminum

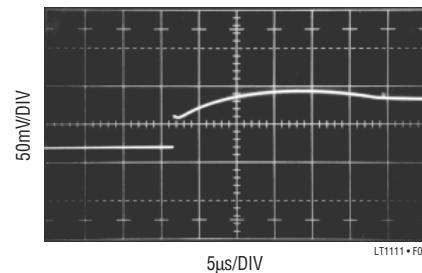

Figure 2. Tantalum

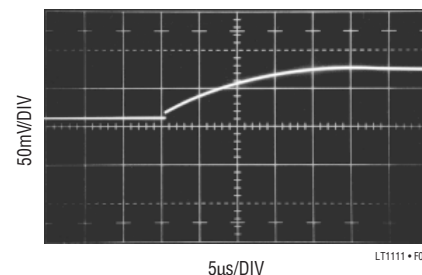

Figure 3. OS-CON

APPLICATIONS INFORMATION

Diode Selection

Speed, forward drop, and leakage current are the three main considerations in selecting a catch diode for LT1111 converters. General purpose rectifiers such as the 1N4001 are *unsuitable* for use in *any* switching regulator application. Although they are rated at 1A, the switching time of a 1N4001 is in the 10μs to 50μs range. At best, efficiency will be severely compromised when these diodes are used; at worst, the circuit may not work at all. Most LT1111 circuits will be well served by a 1N5818 Schottky diode, or its surface mount equivalent, the MBRS130T3. The combination of 500mV forward drop at 1A current, fast turn ON and turn OFF time, and 4μA to 10μA leakage current fit nicely with LT1111 requirements. At peak switch currents of 100mA or less, a 1N4148 signal diode may be used. This diode has leakage current in the 1nA to 5nA range at 25°C and lower cost than a 1N5818. (You can also use them to get your circuit up and running, but beware of destroying the diode at 1A switch currents.)

Step-Up (Boost Mode) Operation

A step-up DC/DC converter delivers an output voltage higher than the input voltage. Step-up converters are not short-circuit protected since there is a DC path from input to output.

The usual step-up configuration for the LT1111 is shown in Figure 4. The LT1111 first pulls SW1 low causing $V_{IN} - V_{CESAT}$ to appear across L1. A current then builds up in L1.

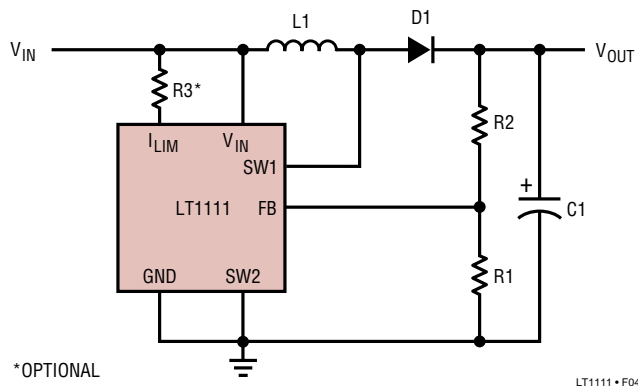

Figure 4. Step-Up Mode Hookup. Refer to Table 1 for Component Values.

At the end of the switch ON time the current in L1 is¹:

$$I_{PEAK} = \frac{V_{IN}}{L} t_{ON} \tag{20}$$

Immediately after switch turn-off, the SW1 voltage pin starts to rise because current cannot instantaneously stop flowing in L1. When the voltage reaches $V_{OUT} + V_D$, the inductor current flows through D1 into C1, increasing V_{OUT} . This action is repeated as needed by the LT1111 to keep V_{FB} at the internal reference voltage of 1.25V. R1 and R2 set the output voltage according to the formula

$$V_{OUT} = \left(1 + \frac{R2}{R1}\right) (1.25V) \tag{21}$$

Step-Down (Buck Mode) Operation

A step-down DC/DC converter converts a higher voltage to a lower voltage. The usual hookup for an LT1111 based step-down converter is shown in Figure 5.

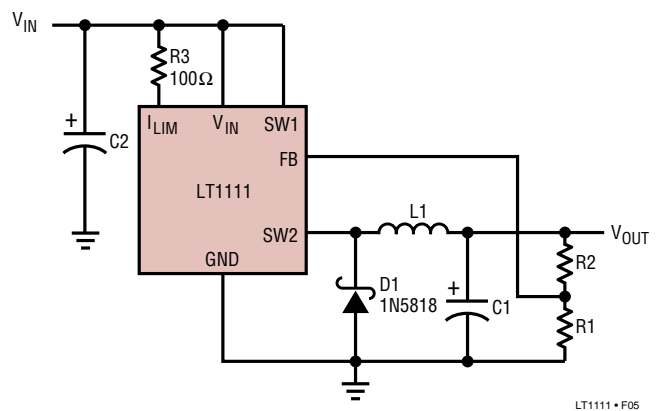

Figure 5. Step-Down Mode Hookup

When the switch turns on, SW2 pulls up to $V_{IN} - V_{SW}$. This puts a voltage across L1 equal to $V_{IN} - V_{SW} - V_{OUT}$, causing a current to build up in L1. At the end of the switch ON time, the current in L1 is equal to:

$$I_{PEAK} = \frac{V_{IN} - V_{SW} - V_{OUT}}{L} t_{ON} \tag{22}$$

Note 1: This simple expression neglects the effect of switch and coil resistance. This is taken into account in the “Inductor Selection” section.

APPLICATIONS INFORMATION

When the switch turns off, the SW2 pin falls rapidly and actually goes below ground. D1 turns on when SW2 reaches 0.4V below ground. *D1 MUST BE A SCHOTTKY DIODE*. The voltage at SW2 must never be allowed to go below $-0.5V$. A silicon diode such as the 1N4933 will allow SW2 to go to $-0.8V$, causing potentially destructive power dissipation inside the LT1111. Output voltage is determined by:

$$V_{OUT} = \left(1 + \frac{R2}{R1}\right) (1.25V) \quad (23)$$

R3 programs switch current limit. This is especially important in applications where the input varies over a wide range. Without R3, the switch stays on for a fixed time each cycle. Under certain conditions the current in L1 can build up to excessive levels, exceeding the switch rating and/or saturating the inductor. The 100Ω resistor programs the switch to turn off when the current reaches approximately 700mA. When using the LT1111 in step-down mode, output voltage should be limited to 6.2V or less. Higher output voltages can be accommodated by inserting a 1N5818 diode in series with the SW2 pin (anode connected to SW2).

Higher Current Step-Down Operation

Output current can be increased by using a discrete PNP pass transistor as shown in Figure 6. R1 serves as a current limit sense. When the voltage drop across R1 equals a V_{BE} , the switch turns off. For temperature compensation a Schottky diode can be inserted in series with the I_{LIM} pin. This also lowers the maximum drop across R1 to $V_{BE} - V_D$, increasing efficiency. As shown, switch current is limited to 2A. Inductor value can be calculated based on formulas in the “Inductor Selection — Step-Down Converter” section with the following conservative expression for V_{SW} :

$$V_{SW} = V_{R1} + V_{Q1SAT} \approx 1.0V \quad (24)$$

R2 provides a current path to turn off Q1. R3 provides base drive to Q1. R4 and R5 set output voltage. A PMOS FET can be used in place of Q1 when V_{IN} is between 10V and 20V.

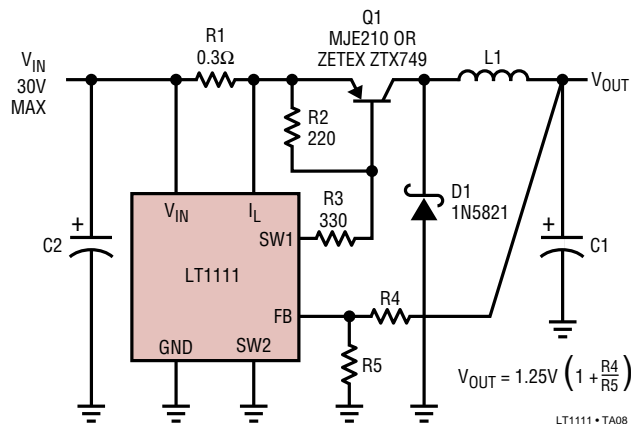

Figure 6. Q1 Permits Higher Current Switching. LT1111 Functions as Controller.

Inverting Configurations

The LT1111 can be configured as a positive-to-negative converter (Figure 7), or a negative-to-positive converter (Figure 8). In Figure 7, the arrangement is very similar to a step-down, except that the high side of the feedback is referred to ground. This level shifts the output negative. As in the step-down mode, D1 must be a Schottky diode, and $|V_{OUT}|$ should be less than 6.2V. More negative output voltages can be accommodated as in the prior section.

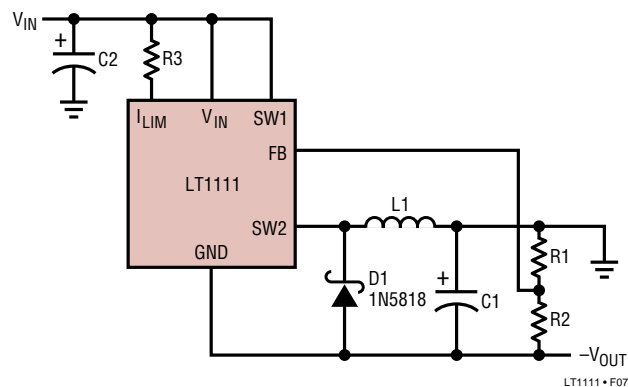

Figure 7. Positive-to-Negative Converter

In Figure 8, the input is negative while the output is positive. In this configuration, the magnitude of the input voltage can be higher or lower than the output voltage. A level shift, provided by the PNP transistor, supplies proper polarity feedback information to the regulator.

APPLICATIONS INFORMATION

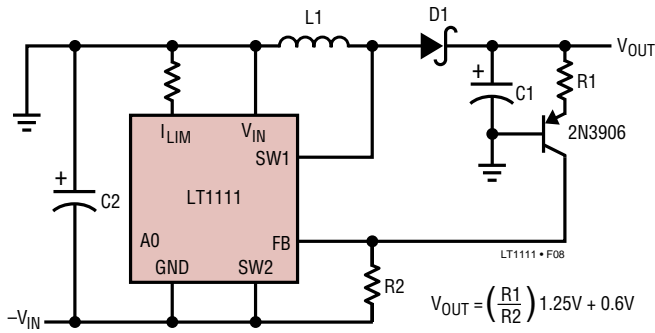

Figure 8. Negative-to-Positive Converter

Using the I_{LIM} Pin

The LT1111 switch can be programmed to turn off at a set switch current, a feature not found on competing devices. This enables the input to vary over a wide range without exceeding the maximum switch rating or saturating the inductor. Consider the case where analysis shows the LT1111 must operate at an 800mA peak switch current with a 2V input. If V_{IN} rises to 4V, the peak switch current will rise to 1.6A, exceeding the maximum switch current rating. With the proper resistor selected (see the “Maximum Switch Current vs I_{LIM}” characteristic), the switch current will be limited to 800mA, even if the input voltage increases.

Another situation where the I_{LIM} feature is useful occurs when the device goes into continuous mode operation. This occurs in step-up mode when:

$$\frac{V_{OUT} + V_{DIODE}}{V_{IN} - V_{SW}} < \frac{1}{1 - DC} \quad (25)$$

When the input and output voltages satisfy this relationship, inductor current does not go to zero during the switch OFF time. When the switch turns on again, the current ramp starts from the non-zero current level in the inductor just prior to switch turn-on. As shown in Figure 9, the inductor current increases to a high level before the comparator turns off the oscillator. This high current can cause excessive output ripple and requires oversizing the output capacitor and inductor. With the I_{LIM} feature, however, the switch current turns off at a programmed level as shown in Figure 10, keeping output ripple to a minimum.

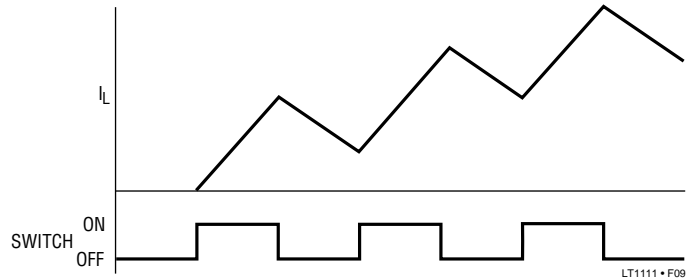

Figure 9. No Current Limit Causes Large Inductor Current Build-Up

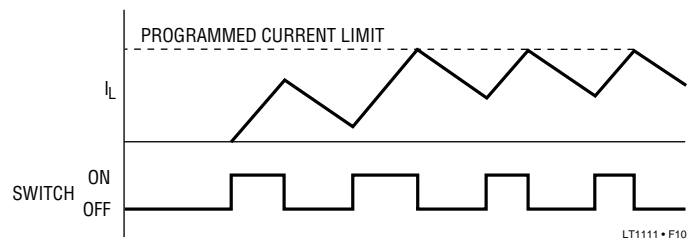

Figure 10. Current Limit Keeps Inductor Current Under Control

Figure 11 details current limit circuitry. Sense transistor Q1, whose base and emitter are paralleled with power switch Q2, is ratioed such that approximately 0.5% of Q2’s collector current flows in Q1’s collector. This current is passed through internal 80Ω resistor R1 and out through the I_{LIM} pin. The value of the external resistor connected between I_{LIM} and V_{IN} sets the current limit. When sufficient switch current flows to develop a V_{BE} across R1 + R_{LIM}, Q3 turns on and injects current into the oscillator, turning off the switch. Delay through this circuitry is approximately 1μs. The current trip point becomes less accurate for switch ON times less than 3μs. Resistor values programming switch ON time for 1μs or less will cause spurious response in the switch circuitry although the device will still maintain output regulation.

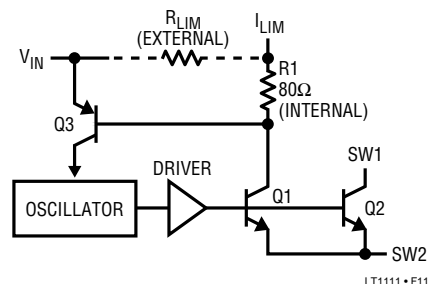

Figure 11. LT1111 Current Limit Circuitry

1111fd

APPLICATIONS INFORMATION

Using the Gain Block

The gain block (GB) on the LT1111 can be used as an error amplifier, low-battery detector or linear post regulator. The gain block itself is a very simple PNP input op amp with an open collector NPN output. The negative input of the gain block is tied internally to the 1.25V reference. The positive input comes out on the SET pin.

Arrangement of the gain block as a low-battery detector is straightforward. Figure 12 shows hookup. R1 and R2 need only be low enough in value so that the bias current of the SET input does not cause large errors. 33k for R2 is adequate. R3 can be added to introduce a small amount of hysteresis. This will cause the gain block to “snap”

when the trip point is reached. Values in the 1M to 10M range are optimal. However, the addition of R3 will change the trip point.

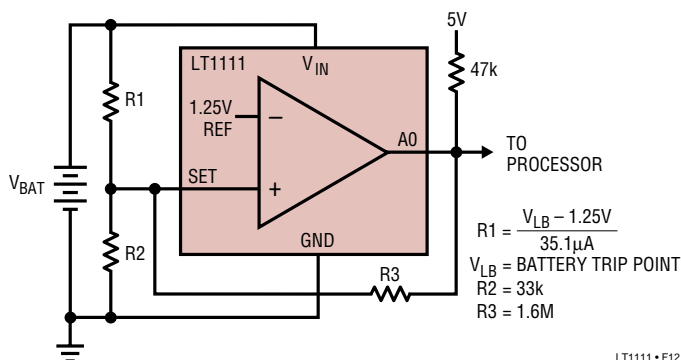

Figure 12. Setting Low-Battery Detector Trip Point

Table 1. Component Selection for Common Converters

INPUT VOLTAGE	OUTPUT VOLTAGE	OUTPUT CURRENT (MIN)	CIRCUIT FIGURE	INDUCTOR VALUE	INDUCTOR PART NUMBER	CAPACITOR VALUE	NOTES
2 to 3.1	5	90mA	4	15μH	S CD75-750K	33μF	*
2 to 3.1	5	10mA	4	47μH	S CD54-470K, C CTX50-1	10μF	
2 to 3.1	12	30mA	4	15μH	S CD75-150K	22μF	
2 to 3.1	12	10mA	4	47μH	S CD54-470K, C CTX50-1	10μF	
5	12	90mA	4	33μH	S CD75-330K	22μF	
5	12	30mA	4	47μH	S CD75-470K, C CTX50-1	15μF	
6.5 to 11	5	50mA	5	15μH	S CD54-150K	47μF	**
12 to 20	5	300mA	5	56μH	S CD105-560K, C CTX50-4	47μF	**
20 to 30	5	300mA	5	120μH	S CD105-121K, C CTX100-4	47μF	**
5	-5	75mA	6	56μH	S CD75-560K, C CTX50-4	47μF	
12	-5	250mA	6	120μH	S CD105-121K, C CTX100-4	100μF	**

S = Sumida

* Add 47Ω from I_{LIM} to V_{IN}

C = Coiltronics

** Add 220Ω from I_{LIM} to V_{IN}

Table 2. Inductor Manufacturers

MANUFACTURER	PART NUMBERS
Coiltronics Incorporated 6000 Park of Commerce Blvd. Boca Raton, FL 33487 407-241-7876	CTX100-4 Series Surface Mount
Toko America Incorporated 1250 Feehanville Drive Mount Prospect, IL 60056 312-297-0070	Type 8RBS
Sumida Electric Co. USA 708-956-0666	CD54 CDR74 CDR105 Surface Mount

Table 3. Capacitor Manufacturers

MANUFACTURER	PART NUMBERS
Sanyo Video Components 1201 Sanyo Avenue San Diego, CA 92073 619-661-6322	OS-CON Series
Nichicon America Corporation 927 East State Parkway Schaumburg, IL 60173 708-843-7500	PL Series
Sprague Electric Company Lower Main Street Sanford, ME 04073 207-324-4140	150D Solid Tantalums 550D Tantalex
Matsuo 714-969-2491	267 Series Surface Mount

1111fd

TYPICAL APPLICATIONS

3V to -22V LCD Bias Generator

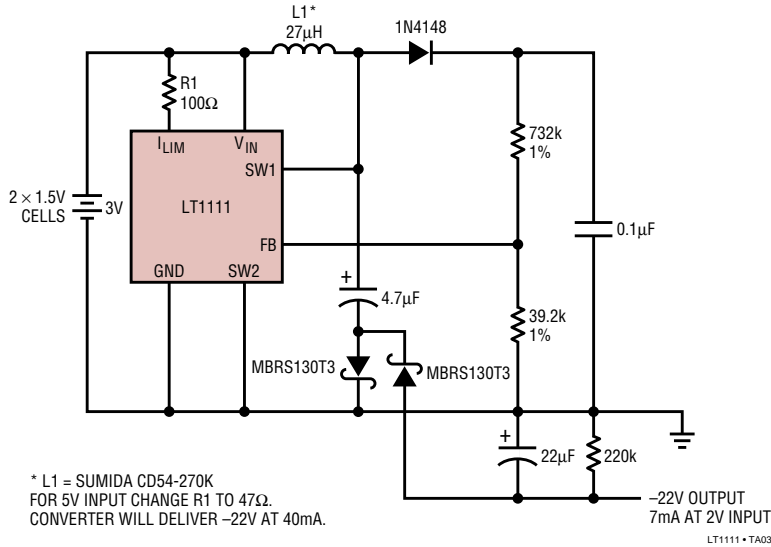

9V to 5V Step-Down Converter

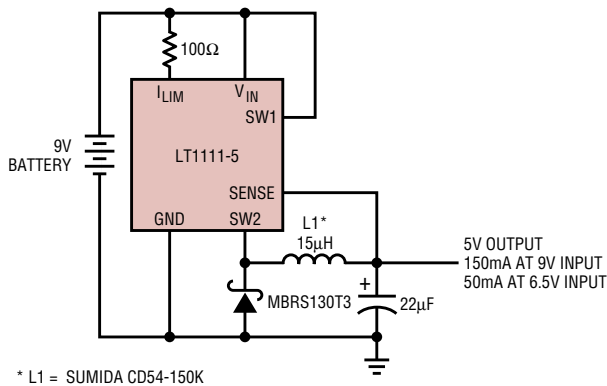

20V to 5V Step-Down Converter

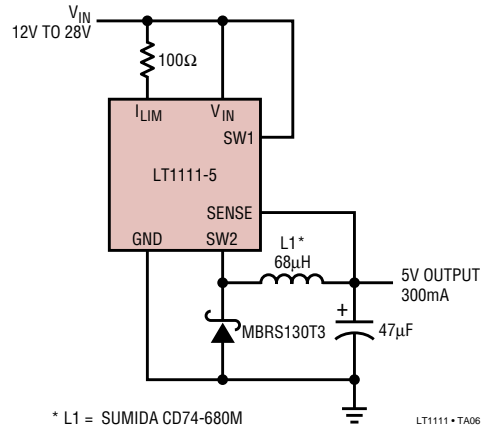

5V to -5V Converter

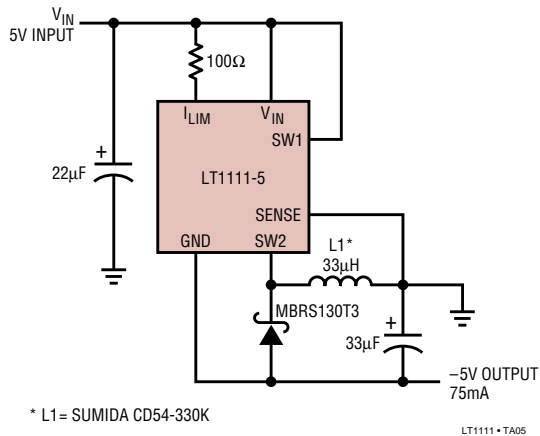

Voltage Controlled Positive-to-Negative Converter

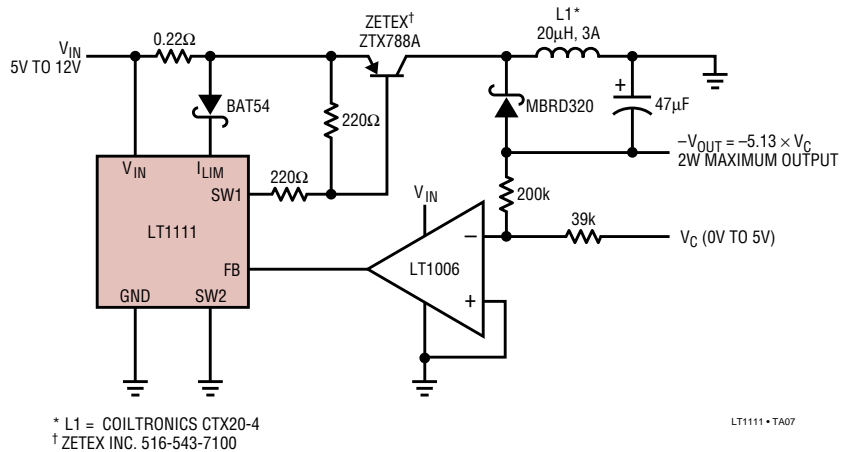

PACKAGE DESCRIPTION

J8 Package 8-Lead CERDIP (Narrow .300 Inch, Hermetic) (Reference LTC DWG # 05-08-1110)

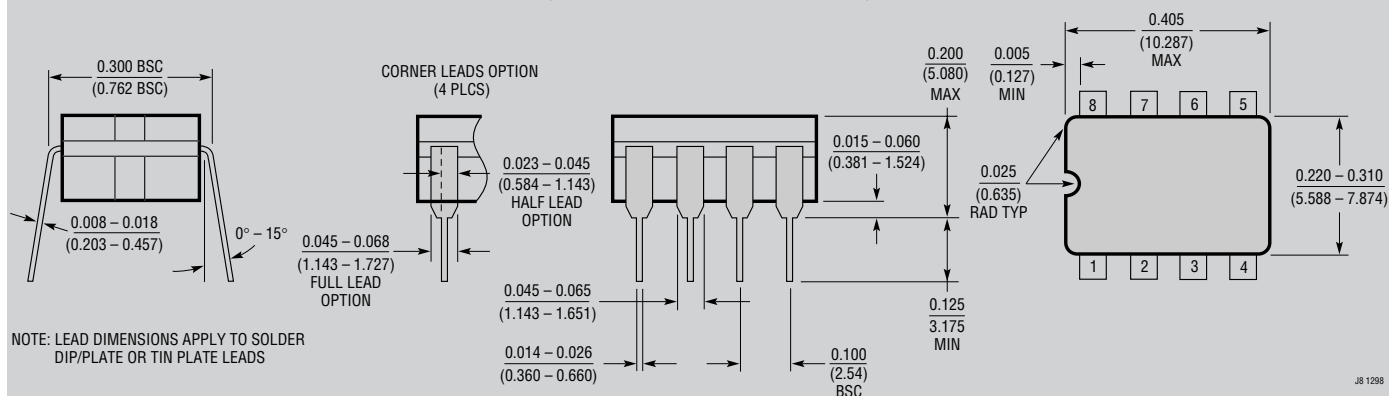

OBSOLETE PACKAGE

N8 Package 8-Lead PDIP (Narrow .300 Inch) (Reference LTC DWG # 05-08-1510)

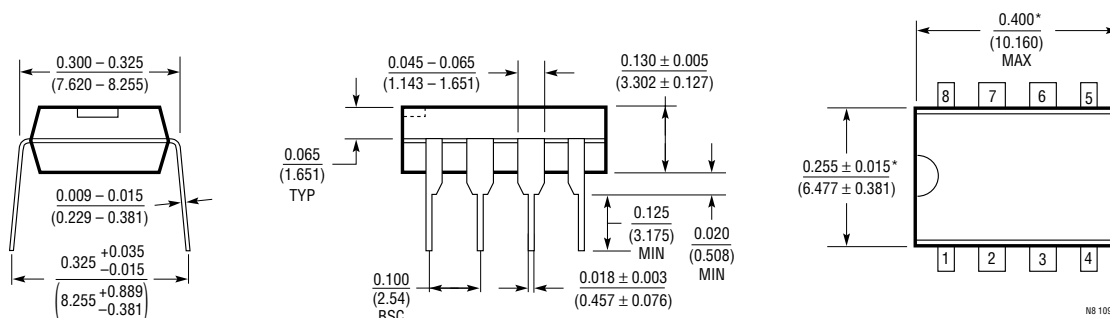

*THESE DIMENSIONS DO NOT INCLUDE MOLD FLASH OR PROTRUSIONS. MOLD FLASH OR PROTRUSIONS SHALL NOT EXCEED 0.010 INCH (0.254mm)

S8 Package 8-Lead Plastic Small Outline (Narrow .150 Inch) (Reference LTC DWG # 05-08-1610)

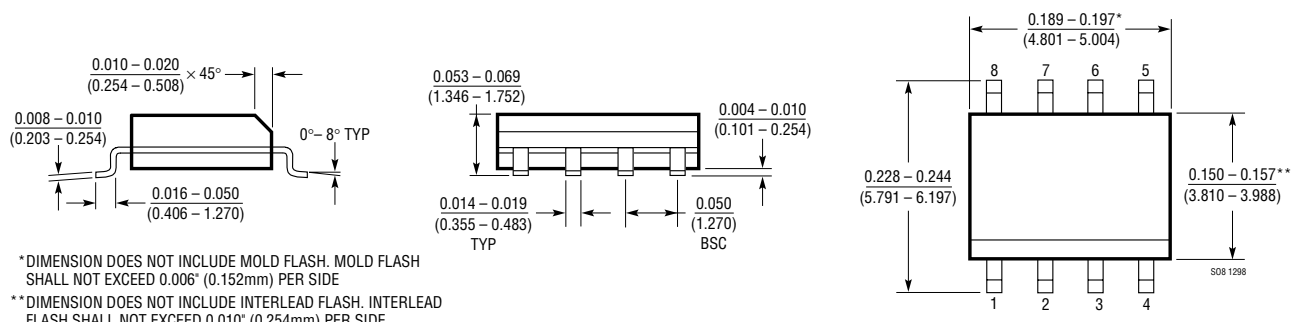

* DIMENSION DOES NOT INCLUDE MOLD FLASH. MOLD FLASH SHALL NOT EXCEED 0.006* (0.152mm) PER SIDE
** DIMENSION DOES NOT INCLUDE INTERLEAD FLASH. INTERLEAD FLASH SHALL NOT EXCEED 0.010* (0.254mm) PER SIDE

TYPICAL APPLICATIONS

High Power, Low Quiescent Current Step-Down Converter

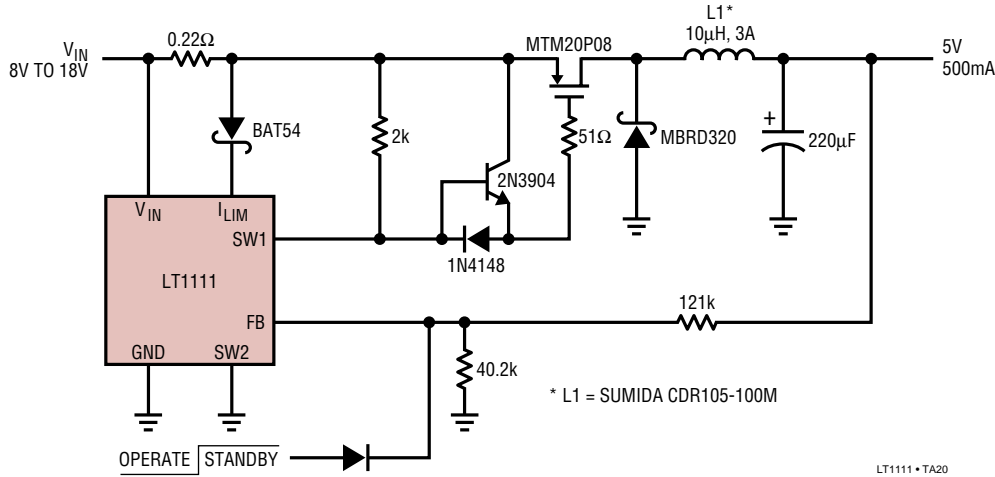

RELATED PARTS

PART NUMBER	DESCRIPTION	COMMENTS
LT1070/LT1070HV	5A I _{SW} , 40kHz, High Efficiency Switching Regulator	V _{IN} = 3V to 40V/60V, V _{OUT} = 65V/75V, I _Q = 6mA, I _{SD} = <50μA, Can be Used for Buck, Boost, Inverting Applications, TO220-5 Package
LT1071/LT1071HV	2.5A I _{SW} , 40kHz, High Efficiency Switching Regulator	V _{IN} = 3V to 40V/60V, V _{OUT} = 65V/75V, I _Q = 6mA, I _{SD} = <50μA, Can be Used for Buck, Boost, Inverting Applications, N8, S8, S16, TO220-5 Packages
LT1072/LT1072HV	1.25A I _{SW} , 40kHz, High Efficiency Switching Regulator	V _{IN} = 3V to 40V/60V, V _{OUT} = 65V/75V, I _Q = 6mA, I _{SD} = <50μA, Can be Used for Buck, Boost, Inverting Applications, N8, S8, S16, TO220-5 Packages
LT1082	1A I _{SW} , 60kHz, High Efficiency Switching Regulator	V _{IN} = 3V to 75V, V _{OUT} = 100V, I _Q = 4.5mA, I _{SD} = ≤120μA, Can be Used for Buck, Boost, Inverting Applications, DD, N8, TO220-5 Packages
LT1107	1A I _{SW} , 63kHz, High Efficiency Switching Regulator	V _{IN} = 2V to 30V, V _{OUT} = 34V, I _Q = 320μA, Can be Used for Buck, Boost, Inverting Applications, N8, S8 Packages
LT1170/LT1170HV	5A I _{SW} , 100kHz, High Efficiency Switching Regulator	V _{IN} = 3V to 40V/60V, V _{OUT} = 65V/75V, I _Q = 6mA, I _{SD} = <50μA, Can be Used for Buck, Boost, Inverting Applications, DD, N8, S16, TO220-5 Packages
LT1171/LT1171HV	2.5A I _{SW} , 100kHz, High Efficiency Switching Regulator	V _{IN} = 3V to 40V/60V, V _{OUT} = 65V/75V, I _Q = 6mA, I _{SD} = <50μA, Can be Used for Buck, Boost, Inverting Applications, DD, N8, S16, TO220-5 Packages
LT1172/LT1172HV	1.25A I _{SW} , 100kHz, High Efficiency Switching Regulator	V _{IN} = 3V to 40V/60V, V _{OUT} = 65V/75V, I _Q = 6mA, I _{SD} = <100μA, Can be Used for Buck, Boost, Inverting Applications, DD, N8, S16, TO220-5 Packages
LT1307/LT1307B	600mA I _{SW} , 600kHz, High Efficiency Step-Up Switching Regulator	V _{IN} = 1V to 12V, V _{OUT} = 28V, I _Q = 50μA/1mA, I _{SD} = ≤1μA Ideal for Single Cell Applications, Low Battery Detect, MS8, N8, S8 Packages
LT1317/LT1317B	660mA I _{SW} , 600kHz, High Efficiency Step-Up Switching Regulator	V _{IN} = 1.5V to 12V, V _{OUT} = 28V, I _Q = 100μA/4.8mA, I _{SD} = ≤30μA/28μA Low Battery Detect, MS8, S8 Packages
LT1370/LT1370HV	6A I _{SW} , 500kHz, High Efficiency Switching Regulator	V _{IN} = 2.7V to 30V, V _{OUT} = 35V/42V, I _Q = 4.5mA, I _{SD} = <12μA, Can be Used for Buck, Boost, Inverting Applications, DD, TO220-7 Packages
LT1371/LT1371HV	3A I _{SW} , 500kHz, High Efficiency Switching Regulator	V _{IN} = 2.7V to 30V, V _{OUT} = 35V/42V, I _Q = 4mA, I _{SD} = <12μA, Can be Used for Buck, Boost, Inverting Applications, DD, S20, TO220-7 Packages