

Triple Monolithic Switching Regulator

FEATURES

- **Wide Input Range: 3.5V to 25V**
- **Three Switching Regulators with Internal Power Switches: 3A Step-Down, 2A Step-Down, 1.5A Inverting/Boost**
- **Antiphase Switching Reduces Ripple**
- Independent Shutdown/Soft-Start Pins
- Independent Power Good Indicators Ease Supply Sequencing
- Input Voltage Power Good Indicators Monitor Input Supply
- Uses Small Inductors and Ceramic Capacitors
- Constant 1.1MHz Switching Frequency
- Thermally Enhanced 28-Lead TSSOP Package

APPLICATIONS

- Cable Modems
- DSL Modems
- Distributed Power Regulation
- Wall Transformer Regulation
- Disk Drives
- DSP Power

LT, LT, LTC and LTM are registered trademarks of Linear Technology Corporation. All other trademarks are the property of their respective owners.

DESCRIPTION

The LT[®]1941 is a triple current mode DC/DC converter with internal power switches. Two of the regulators are step-down converters with 3A and 2A power switches. The third regulator can be configured as a boost, inverter or SEPIC converter and has a 1.5A power switch. All three converters are synchronized to a 1.1MHz oscillator. The two step-down converters run with opposite phase, reducing input ripple current. The output voltages are set with external resistor dividers and each regulator has independent shutdown and soft-start circuits. Each regulator generates a power good signal when its output is in regulation, easing power supply sequencing and interfacing with microcontrollers and DSPs.

The high switching frequency offers several advantages by permitting the use of small inductors and ceramic capacitors, leading to a very small triple output solution. The constant switching frequency, combined with low impedance ceramic capacitors, result in low, predictable output ripple. With its wide input voltage range of 3.5V to 25V, the LT1941 regulates a broad array of power sources from 4-cell batteries and 5V logic rails to unregulated wall transformers, lead acid batteries and distributed-power supplies.

TYPICAL APPLICATION

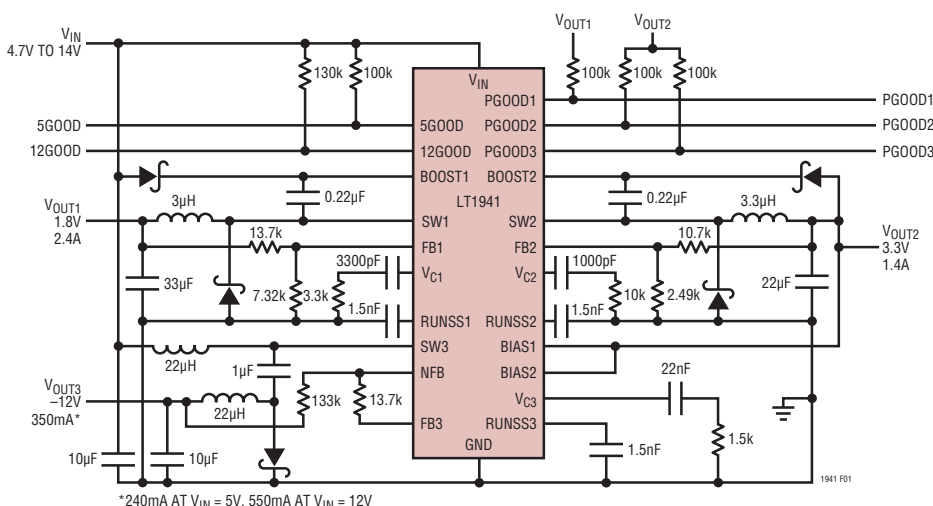
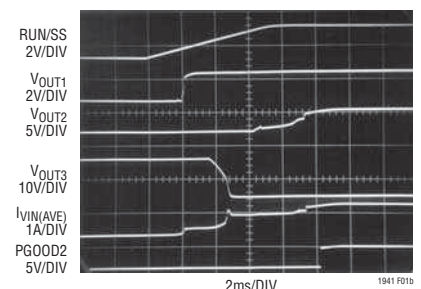

Figure 1. Triple Output Power Supply: 3.3V, 1.8V, -12V

Start-Up Waveforms with Sequencing



LT1941

ABSOLUTE MAXIMUM RATINGS

(Note 1)

V_{IN} Pin	(-0.3V), 25V
BOOST Pin Voltage	35V
BOOST Above SW Pin	25V
BIAS1, BIAS2 Pins	25V
PGOOD, 5GOOD, 12GOOD Pins	25V
RUN/SS, V_C , FB, NFB Pins	3V
SW1, SW2 Voltage	V_{IN}
SW3 Voltage	40V
Maximum Junction Temperature (Note 6)	125°C
Operating Ambient Temperature Range (Note 2)	-40°C to 85°C
Storage Temperature Range	-65°C to 150°C
Lead Temperature (Soldering, 10 sec)	300°C

PIN CONFIGURATION

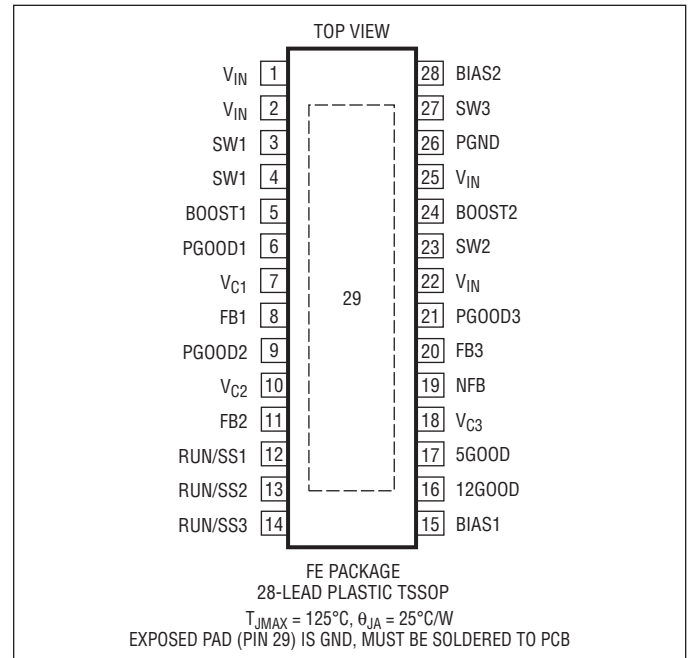

ORDER INFORMATION

LEAD FREE FINISH	TAPE AND REEL	PART MARKING	PACKAGE DESCRIPTION	TEMPERATURE RANGE
LT1941EFE#PBF	LT1941EFE#TRPBF	LT1941EFE	28-LEAD PLASTIC TSSOP	-40°C to 85°C
LEAD BASED FINISH	TAPE AND REEL	PART MARKING	PACKAGE DESCRIPTION	TEMPERATURE RANGE
LT1941EFE	LT1941EFE#TR	LT1941EFE	28-LEAD PLASTIC TSSOP	-40°C to 85°C

Consult LTC Marketing for parts specified with wider operating temperature ranges.

For more information on lead free part marking, go to: <http://www.linear.com/leadfree/>

For more information on tape and reel specifications, go to: <http://www.linear.com/tapeandreeel/>

ELECTRICAL CHARACTERISTICS

The ● denotes the specifications which apply over the full operating temperature range, otherwise specifications are at $T_A = 25^\circ\text{C}$. V_{IN} , V_{BIAS1} , $V_{BIAS2} = 5\text{V}$, V_{BOOST1} , $V_{BOOST2} = 8\text{V}$, unless otherwise noted. (Note 2)

PARAMETER	CONDITIONS	MIN	TYP	MAX	UNITS	
Minimum Operating Voltage		●	3.3	3.5	V	
V_{IN} Quiescent Current	Not Switching		2	3.5	mA	
BIAS1 Quiescent Current	Not Switching		5	7.5	mA	
BIAS2 Quiescent Current	Not Switching		1.6	2.2	mA	
Shutdown Current	$V_{RUNSS1,2,3} = 0\text{V}$		50	75	μA	
Reference Voltage Line Regulation	$5\text{V} < V_{IN} < 25\text{V}$		0.01		%/V	
V_C Source Current	$V_C = 0.6\text{V}$		100		μA	
V_C Sink Current	$V_C = 0.6\text{V}$		100		μA	
V_C Clamp Voltage			1.7		V	
Switching Frequency		●	0.9	1.1	1.35	MHz

1941fb

ELECTRICAL CHARACTERISTICS The ● denotes the specifications which apply over the full operating temperature range, otherwise specifications are at $T_A = 25^\circ\text{C}$. V_{IN} , V_{BIAS1} , $V_{BIAS2} = 5\text{V}$, V_{BOOST1} , $V_{BOOST2} = 8\text{V}$, unless otherwise noted. (Note 2)

PARAMETER	CONDITIONS	MIN	TYP	MAX	UNITS
Switching Phase	SW1 to SW2 SW1 to SW3	150 -30	180 0	210 30	Deg Deg
Foldback Frequency	$V_{FB} = 0\text{V}$		200		kHz
RUN/SS Current		1	2	3	μA
RUN/SS Threshold		0.4	0.6		V
5GOOD Threshold	V_{IN} Rising		4.5		V
5GOOD Voltage Output Low	$I_{5GOOD} = 125\mu\text{A}$, $V_{IN} = 4\text{V}$		0.2	0.4	V
5GOOD Leakage	$V_{5GOOD} = 2\text{V}$		10	400	nA
12GOOD Threshold	V_{IN} Rising		10.8		V
12GOOD Voltage Output Low	$I_{12GOOD} = 125\mu\text{A}$		0.2	0.4	V
12GOOD Leakage	$V_{12GOOD} = 2\text{V}$, $V_{IN} = 12\text{V}$		10	400	nA
PGOOD Voltage Output Low	$I_{PGOOD} = 200\mu\text{A}$		0.2	0.4	V
PGOOD Pin Leakage	$V_{PGOOD} = 2\text{V}$		10	400	nA

3A Step-Down

FB1 Voltage		●	618 613	628	638 638	mV mV
FB1 Pin Bias Current		●		50	500	nA
PGOOD1 Threshold Offset	V_{FB} Rising			54		mV
Frequency Shift Threshold on FB1				0.35		V
Error Amplifier Transconductance				1700		μMhos
Error Amplifier Voltage Gain				500		V/V
V_C Switching Threshold				0.9		V
V_{C1} to Switch Current Gain				5		A/V
Switch 1 Current Limit (Note 3)	$V_{IN} = 12\text{V}$, V_{BOOST1} , $V_{BOOST2} = 15\text{V}$	●	3	4.3	6	A
Switch 1 V_{CESAT} (Note 7)	$I_{SW} = 2.5\text{A}$			400	600	mV
BOOST1 Pin Current	$I_{SW} = 2.5\text{A}$			40	60	mA
Switch 1 Leakage Current				0.01	10	μA
Minimum Boost Voltage Above Switch (Note 4)				1.8	2.5	V
Maximum Duty Cycle		●	78	88		%

2A Step-Down

FB2 Voltage		●	618 613	628	638 638	mV mV
FB2 Pin Bias Current		●		50	500	nA
PGOOD2 Threshold Offset	V_{FB} Rising			54		mV
Frequency Shift Threshold on FB2				0.35		V
Error Amplifier Transconductance				1700		μMhos
Error Amplifier Voltage Gain				500		V/V
V_C Switching Threshold				0.9		V
V_{C2} to Switch Current Gain				3.6		A/V
Switch 2 Current Limit (Note 3)	$V_{IN} = 12\text{V}$, V_{BOOST1} , $V_{BOOST2} = 15\text{V}$	●	2	2.9	4.1	A
Switch 2 V_{CESAT} (Note 7)	$I_{SW} = 1.5\text{A}$			450	600	mV
BOOST2 Pin Current	$I_{SW} = 1.5\text{A}$			26	40	mA

ELECTRICAL CHARACTERISTICS

The ● denotes the specifications which apply over the full operating temperature range, otherwise specifications are at $T_A = 25^\circ\text{C}$. V_{IN} , V_{BIAS1} , $V_{BIAS2} = 5\text{V}$, V_{BOOST1} , $V_{BOOST2} = 8\text{V}$, unless otherwise noted. (Note 2)

PARAMETER	CONDITIONS		MIN	TYP	MAX	UNITS
Switch 2 Leakage Current				0.01	10	μA
Minimum Boost Voltage Above Switch (Note 4)				1.8	2.5	V
Maximum Duty Cycle		●	78	88		%
1.5A Inverting/Boost						
FB3 Voltage		●	1.23 1.22	1.25	1.27 1.27	V V
FB3 Pin Bias Current		●		800	1400	nA
NFB Voltage		●	-15	0	15	mV
NFB Pin Bias Current		●		60	500	nA
NFB3 Voltage ($V_{FB3} - V_{NFB}$)		●	1.212 1.205	1.24	1.258 1.260	V V
FB3 Pin Output Current	$V_{FB3} = 1.35\text{V}$, $V_{NFB} = -0.1\text{V}$	●	150	350		μA
PGOOD3 Threshold Offset	V_{FB} Rising			120		mV
Error Amplifier Transconductance				800		μMhos
Error Amplifier Voltage Gain				150		V/V
V_C Switching Threshold				1.1		V
V_{C3} to Switch Current Gain				5		A/V
Frequency Shift Threshold on FB3				0.65		V
Switch 3 Current Limit (Note 5)		●	1.5	2	2.9	A
Switch 3 V_{CESAT}	$I_{SW} = 1\text{A}$			240	320	mV
BIAS2 Pin Current	$I_{SW} = 1\text{A}$			30	45	mA
Switch 3 Leakage Current				0.01	10	μA
Maximum Duty Cycle		●	77	86		%

Note 1: Stresses beyond those listed under Absolute Maximum Ratings may cause permanent damage to the device. Exposure to any Absolute Maximum Rating condition for extended periods may affect device reliability and lifetime.

Note 2: The LT1941E is guaranteed to meet performance specifications from 0°C to 70°C . Specifications over the -40°C to 85°C operating temperature range are assured by design, characterization and correlation with statistical process controls.

Note 3: Current limit is guaranteed by design and/or correlation to static test. Slope compensation reduces current limit at higher duty cycles.

Note 4: This is the minimum voltage across the boost capacitor needed to guarantee full saturation of the internal power switch.

Note 5: Current limit is guaranteed by design and/or correlation to static test.

Note 6: This IC includes overtemperature protection that is intended to protect the device during momentary overload conditions. Junction temperature will exceed 125°C when overtemperature protection is active. Continuous operation above the specified maximum operating junction temperature may impair device reliability.

Note 7: Guaranteed by design, not 100% tested.

TYPICAL PERFORMANCE CHARACTERISTICS

Efficiency, $V_{OUT1} = 1.8V$

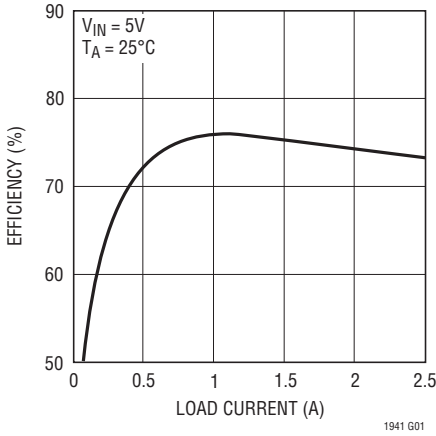

Efficiency, $V_{OUT2} = 3.3V$

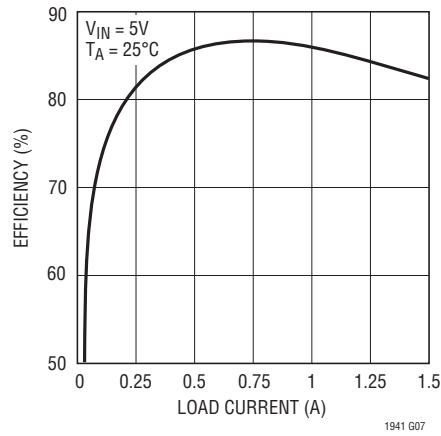

Efficiency, $V_{OUT3} = -12V$

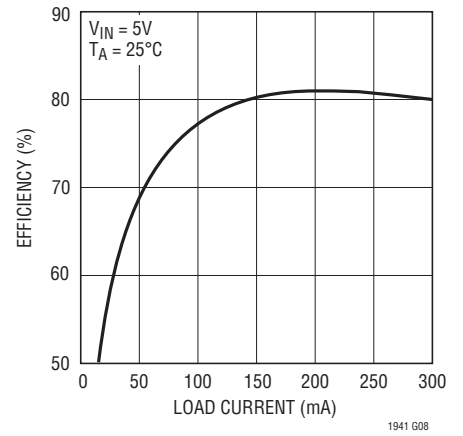

SW1 V_{CESAT}

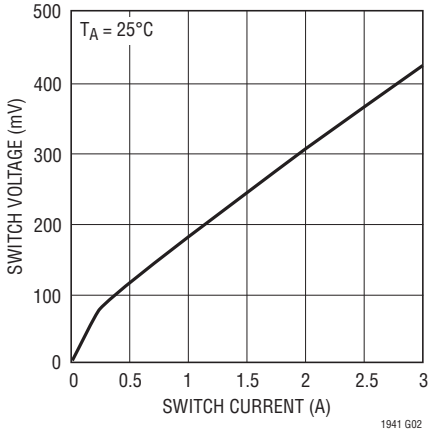

SW2 V_{CESAT}

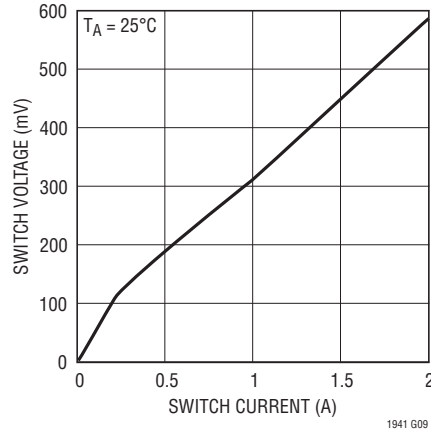

SW3 V_{CESAT}

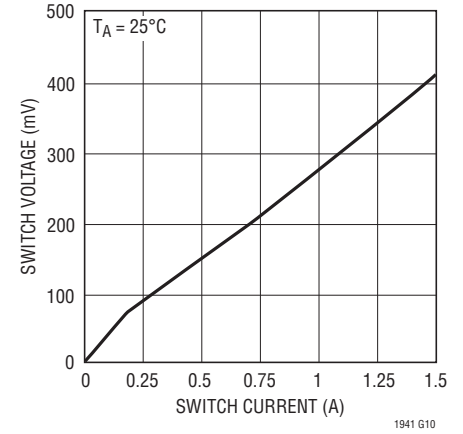

SW1 Current Limit vs Duty Cycle

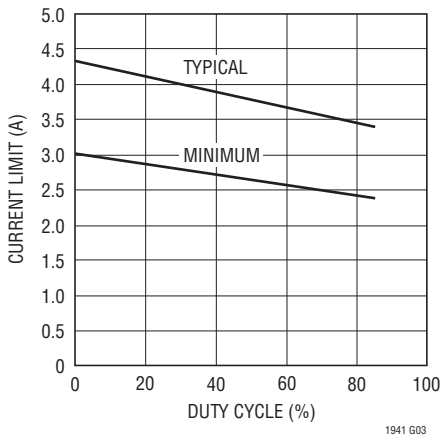

SW2 Current Limit vs Duty Cycle

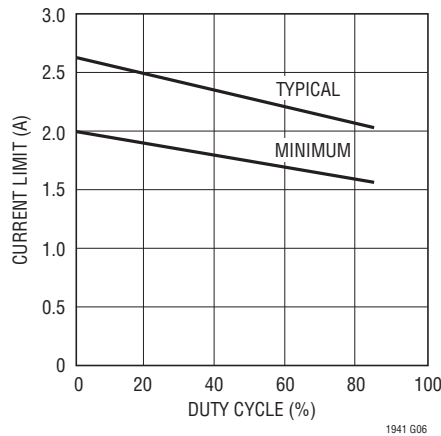

BOOST2 Pin Current

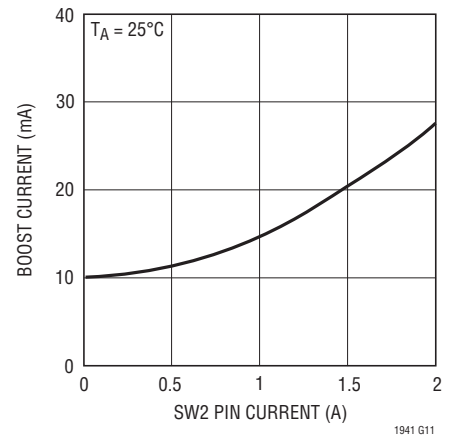

TYPICAL PERFORMANCE CHARACTERISTICS

BOOST1 Pin Current

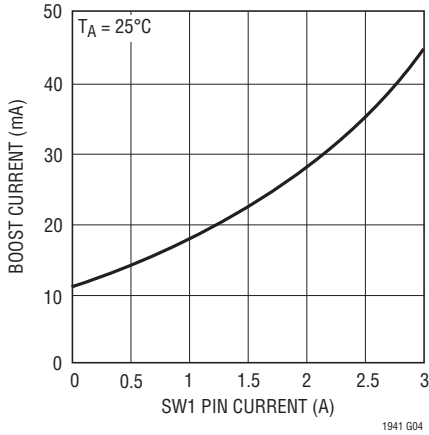

V_{FB3} vs Temperature

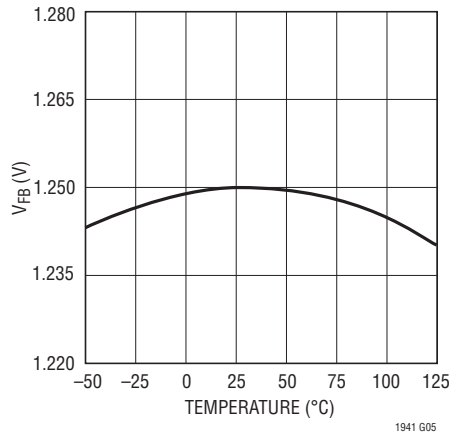

V_{FB1} , V_{FB2} vs Temperature

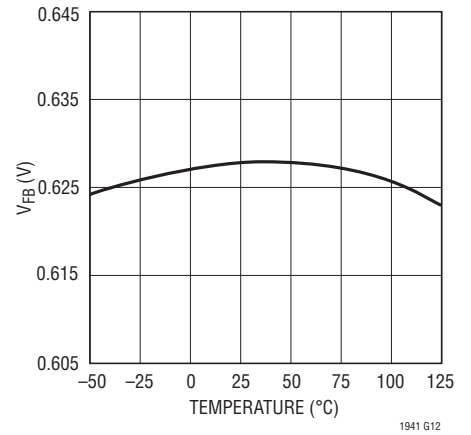

Frequency vs Temperature

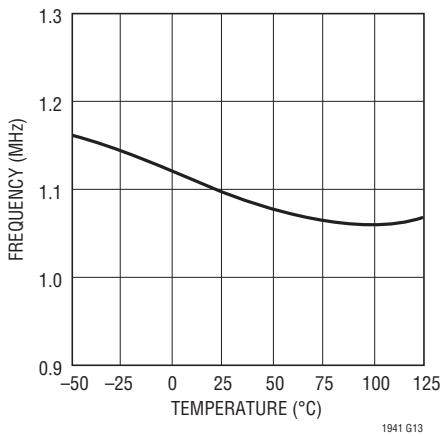

Switching Frequency vs % of Feedback Voltage

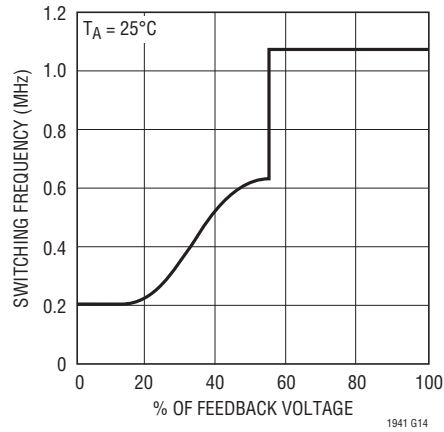

$I_{RUN/SS}$ vs Temperature

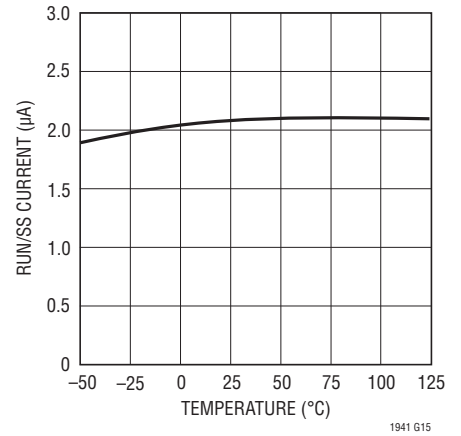

RUN/SS Thresholds vs Temperature

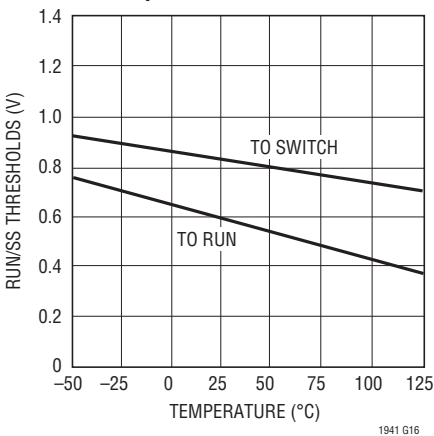

Minimum Input Voltage $V_{OUT2} = 5V$

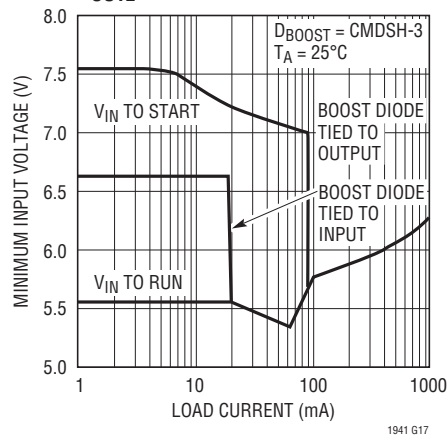

Minimum Input Voltage $V_{OUT2} = 3.3V$

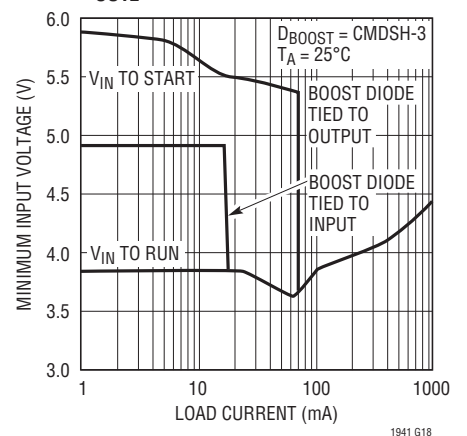

PIN FUNCTIONS

V_{IN} (Pins 1, 2, 22, 25): The V_{IN} pins supply current to the LT1941's internal circuitry and to the internal power switches. These pins must be tied to the same source and locally bypassed.

SW1, SW2, SW3 (Pins 3, 4, 23, 27): The SW pins are the outputs of the internal power switches. Connect these pins to the inductors and switching diodes.

BOOST1, BOOST2 (Pins 5, 24): The BOOST pins are used to provide drive voltages, higher than the input voltage, to the internal bipolar NPN power switches. Tie through a diode from V_{OUT} or from V_{IN}.

PGOOD1, PGOOD2, PGOOD3 (Pins 6, 9, 21): The PGOOD pins are the open-collector outputs of an internal comparator. PGOOD remains low until the FB pin is within 10% of the final regulation voltage. As well as indicating output regulation, the PGOOD pins can sequence the switching regulators. Leave these pins unconnected if unused. The PGOOD outputs are valid when V_{IN} is greater than 3.5V and any of the RUN/SS pins are high. They are **not** valid when all RUN/SS pins are low.

V_{C1}, V_{C2}, V_{C3} (Pins 7, 10, 18): The V_C pins are the outputs of the internal error amps. The voltages on these pins control the peak switch currents. These pins are normally used to compensate the control loops. Each switching regulator can be shut down by pulling its respective V_C pin to ground with an NMOS or NPN transistor.

FB1, FB2, FB3 (Pins 8, 11, 20): The LT1941 regulates each feedback pin to either 0.628V (FB1, FB2) or 1.25V (FB3). Connect the feedback resistor divider taps to these pins.

RUN/SS1, RUN/SS2, RUN/SS3 (Pins 12, 13, 14): The RUN/SS pins are used to shut down the individual switching regulators and the internal bias circuits. They also provide a soft-start function. To shut down either regulator, pull the RUN/SS pin to ground with an open drain or collector. Tie a capacitor from this pin to ground to limit switch current during start-up. If neither feature is used, leave these pins unconnected.

BIAS1 (Pin 15): The BIAS1 pin supplies the current to the LT1941's internal regulator. Tie this pin to the lowest available voltage source above 2.35V (Either V_{IN}, V_{OUT} or any other available supply).

12GOOD (Pin 16): The 12GOOD pin is the open-collector output of an internal comparator. 12GOOD remains low until V_{IN} is within 10% of 12V. The pin pulls low when the part is in shutdown. Leave this pin unconnected if unused.

5GOOD (Pin 17): The 5GOOD pin is the open-collector output of an internal comparator. 5GOOD remains low until V_{IN} is within 10% of 5V. The pin pulls low when the part is in shutdown. Leave this pin unconnected if unused.

NFB (Pin 19): The LT1941 contains an op amp configured with an output at FB3, noninverting terminal at GND and an inverting terminal at NFB. Connect the feedback resistor network virtual ground at this node if regulating negative voltages. Otherwise, tie this node to FB3.

PGND (Pin 26): Tie directly to local ground plane.

BIAS2 (Pin 28): The BIAS2 pin supplies the current to the driver of SW3. Tie this pin to the lowest available voltage source above 2.5V (Either V_{IN}, V_{OUT} or any other available supply).

Exposed Pad (Pin 29): Ground. The underside Exposed Pad metal of the package provides both electrical contact to ground and good thermal contact to the printed circuit board. The Exposed Pad must be soldered to the circuit board ground for proper operation.

BLOCK DIAGRAM

The LT1941 is a constant frequency, current mode, triple output regulator with internal power switches. The three regulators share common circuitry including input source, voltage reference and oscillator, but are otherwise independent. Operation can be best understood by referring to the Block Diagram.

If the RUN/SS pins are tied to ground, the LT1941 is shut down and draws 50 μ A from the input source tied to V_{IN} . Internal 2 μ A current sources charge external soft-start capacitors, generating voltage ramps at these pins. If any of the RUN/SS pins exceed 0.6V, the internal bias circuits turn on, including the internal regulator, reference and 1.1MHz master oscillator. Each switching regulator will only begin to operate when its corresponding RUN/SS pin reaches \approx 1V. The master oscillator generates three clock signals, with the two signals for the step-down regulators out of phase by 180°.

The three switchers are current mode regulators. Instead of directly modulating the duty cycle of the power switch, the feedback loop controls the peak current in the switch during each cycle. Compared to voltage mode control, current mode control improves loop dynamics and provides cycle-by-cycle current limit.

The Block Diagram shows only one of the two step-down switching regulators. A pulse from the slave oscillator sets the RS flip-flop and turns on the internal NPN bipolar power switch. Current in the switch and the external inductor begins to increase. When this current exceeds a level determined by the voltage at V_C , current comparator C1 resets the flip-flop, turning off the switch. The current in the inductor flows through the external Schottky diode and begins to decrease. The cycle begins again at the next pulse from the oscillator. In this way, the voltage on the V_C pin controls the current through the inductor to the output. The internal error amplifier regulates the output voltage by continually adjusting the V_C pin voltage. The threshold for switching on the V_C pin is \approx 1V and an active clamp of 1.7V limits the output current. The RUN/SS pin voltage also clamps the V_C pin voltage. As the internal current source charges the external soft-start capacitor, the current limit increases slowly. An internal op amp allows the part to regulate negative voltages using only two external resistors.

Each switcher contains an extra, independent oscillator to perform frequency foldback during overload conditions. This slave oscillator is normally synchronized to the master oscillator. A comparator senses when V_{FB} is less than 50% of its regulated value and switches the regulator from the master oscillator to a slower slave oscillator. The V_{FB} pin is less than 50% of its regulated value during start-up, short circuit and overload conditions. Frequency foldback helps limit switch current under these conditions.

The switch drivers for SW1 and SW2 operate either from V_{IN} or from the BOOST pin. An external capacitor and diode are used to generate a voltage at the BOOST pin that is higher than the input supply. This allows the driver to saturate the internal bipolar NPN power switch for efficient operation.

The BIAS1 pin allows the internal circuitry to draw its current from a lower voltage supply than the input, also reducing power dissipation and increasing efficiency. If the voltage on the BIAS1 pin falls below 2.35V, then its quiescent current will flow from V_{IN} .

The BIAS2 pin allows the driver for SW3 to draw its current from a lower voltage supply than the input. This reduces power dissipation within the part and increases efficiency. If the voltage on the BIAS2 pin falls below \approx 2V, then SW3 will lock out and will not be able to turn on until BIAS2 rises above \approx 2.1V.

A power good comparator trips when the FB pin is at 91% of its regulated value. The PGOOD output is an open-collector transistor that is off when the output is in regulation, allowing an external resistor to pull the PGOOD pin high. Power good is valid when the LT1941 is enabled and $V_{IN} > 3.5V$.

Input power good comparators monitor the input supply. The 5GOOD and 12GOOD pins are open-collector outputs of internal comparators. The 5GOOD pin remains low until the input is within 10% of 5V. The 12GOOD pin remains low until the input is within 10% of 12V. The 5GOOD and 12GOOD pins are valid as long as V_{IN} is greater than 1.1V. Both the 5GOOD and 12GOOD pins will sink current when the part is in shutdown, independent of the voltage at V_{IN} .

BLOCK DIAGRAM

One of Two Step-Down Switching Regulators

Inverting/Boost Switching Regulator

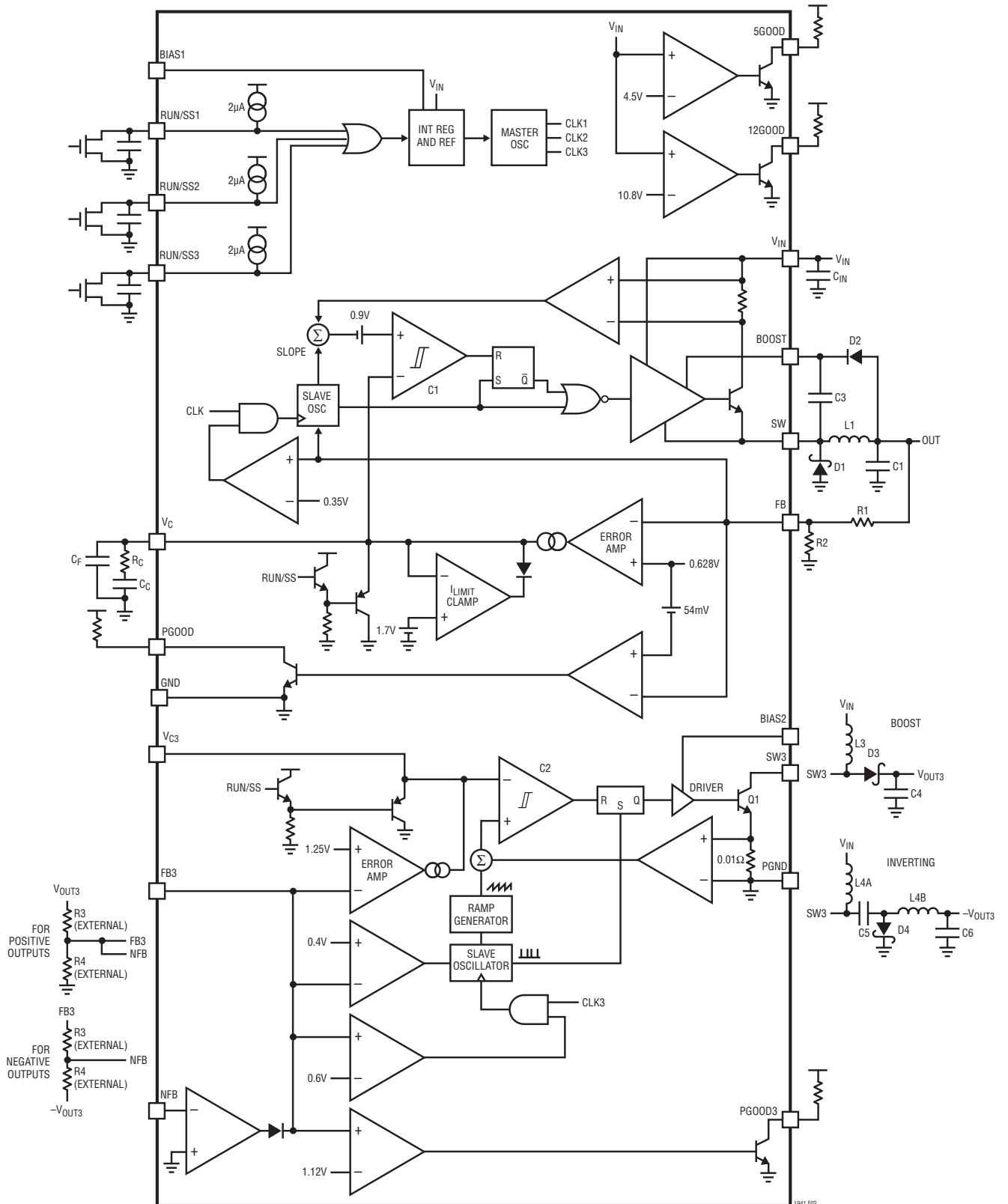

Figure 2. Block Diagram of the LT1941 with Associated External Components

APPLICATIONS INFORMATION

STEP-DOWN CONSIDERATIONS

FB Resistor Network

The output voltage is programmed with a resistor divider (refer to the Block Diagram) between the output and the FB pin. Choose the resistors according to

$$R1 = R2(V_{OUT}/628mV - 1)$$

R2 should be 10k or less to avoid bias current errors.

Input Voltage Range

The minimum operating voltage is determined either by the LT1941's undervoltage lockout of ~3.3V or by its maximum duty cycle. The duty cycle is the fraction of time that the internal switch is on and is determined by the input and output voltages:

$$DC = (V_{OUT} + V_F)/(V_{IN} - V_{SW} + V_F)$$

where V_F is the forward voltage drop of the catch diode (~0.4V) and V_{SW} is the voltage drop of the internal switch (~0.3V at maximum load). This leads to a minimum input voltage of:

$$V_{IN(MIN)} = (V_{OUT} + V_F)/DC_{MAX} - V_F + V_{SW}$$

with $DC_{MAX} = 0.78$.

The maximum operating voltage is determined by the absolute maximum ratings of the V_{IN} and BOOST pins and by the minimum duty cycle $DC_{MIN} = 0.15$:

$$V_{IN(MAX)} = (V_{OUT} + V_F)/DC_{MIN} - V_F + V_{SW}$$

This limits the maximum input voltage to ~14V with $V_{OUT} = 1.8V$ and ~19V with $V_{OUT} = 2.5$. Note that this is a restriction on the operating input voltage; the circuit will tolerate input voltage transients up to the Absolute Maximum Rating.

Inductor Selection and Maximum Output Current

A good first choice for the inductor value is

$$L = (V_{OUT} + V_F)/1.6 \text{ for SW1}$$

$$L = (V_{OUT} + V_F)/1.1 \text{ for SW2}$$

where V_F is the voltage drop of the catch diode (~0.4V) and L is in μH . With this value the maximum load current will be 2.1A for SW1 and 1.4A for SW2, independent of input voltage. The inductor's RMS current rating must be greater than the maximum load current and its saturation current should be at least 30% higher. For highest efficiency, the series resistance (DCR) should be less than 0.1Ω . Table 1 lists several vendors and types that are suitable.

Table 1. Inductors

PART NUMBER	VALUE (μH)	I_{SAT} (A)	DCR (Ω)	HEIGHT (mm)
Sumida				
CR43-1R4	1.4	2.52	0.056	3.5
CR43-2R2	2.2	1.75	0.071	3.5
CDRH3D16-1R5	1.5	1.55	0.040	1.8
CDRH4D28-3R3	3.3	1.57	0.049	3.0
CDRH4D18-1R0	1.0	1.70	0.035	2.0
CDC5D23-2R2	2.2	2.50	0.03	2.5
CDRH5D28-2R6	2.6	2.60	0.013	3.0
Coilcraft				
DO1606T-152	1.5	2.10	0.060	2.0
DO1606T-222	2.2	1.70	0.070	2.0
DO1608C-152	1.5	2.60	0.050	2.9
DO1608C-222	2.2	2.30	0.070	2.9
DO1608C-332	3.3	2.00	0.080	2.9
DO1608C-472	4.7	1.50	0.090	2.9
MOS6020-222	2.2	2.15	0.035	2.0
MOS6020-332	3.3	1.8	0.046	2.0
MOS6020-472	4.7	1.5	0.050	2.0
DO3314-222	2.2	1.6	0.200	1.4
Toko				
(D62F)847FY-2R4M	2.4	2.5	0.037	2.7
(D73LF)817FY-2R2M	2.2	2.7	0.03	3.0

The optimum inductor for a given application may differ from the one indicated by this simple design guide. A larger value inductor provides a slightly higher maximum load current and will reduce the output voltage ripple. If

APPLICATIONS INFORMATION

your load is lower than the maximum load current, then you can relax the value of the inductor and operate with higher ripple current. This allows you to use a physically smaller inductor or one with a lower DCR resulting in higher efficiency. Be aware that if the inductance differs from the simple rule above, then the maximum load current will depend on input voltage. In addition, low inductance may result in discontinuous mode operation, which further reduces maximum load current. For details of maximum output current and discontinuous mode operation, see Linear Technology's Application Note AN44. Finally, for duty cycles greater than 50% ($V_{OUT}/V_{IN} > 0.5$), a minimum inductance is required to avoid subharmonic oscillations. See AN19.

The current in the inductor is a triangle wave with an average value equal to the load current. The peak switch current is equal to the output current plus half the peak-to-peak inductor ripple current. The LT1941 limits its switch current in order to protect itself and the system from overload faults. Therefore, the maximum output current that the LT1941 will deliver depends on the switch current limit, the inductor value and the input and output voltages.

When the switch is off, the potential across the inductor is the output voltage plus the catch diode drop. This gives the peak-to-peak ripple current in the inductor:

$$\Delta I_L = (1 - DC)(V_{OUT} + V_F)/(L \cdot f)$$

where f is the switching frequency of the LT1941 and L is the value of the inductor. The peak inductor and switch current is:

$$I_{SWPK} = I_{LPK} = I_{OUT} + \Delta I_L/2$$

To maintain output regulation, this peak current must be less than the LT1941's switch current limit I_{LIM} . For SW1, I_{LIM} is at least 3A at low duty cycles and decreases linearly to 2.4A at $DC = 0.8$. For SW2, I_{LIM} is at least 2A for at low

duty cycles and decreases linearly to 1.6A at $DC = 0.8$. The maximum output current is a function of the chosen inductor value:

$$\begin{aligned} I_{OUT(MAX)} &= I_{LIM} - \Delta I_L/2 \\ &= 3 \cdot (1 - 0.25 \cdot DC) - \Delta I_L/2 \text{ for SW1} \\ &= 2 \cdot (1 - 0.25 \cdot DC) - \Delta I_L/2 \text{ for SW2} \end{aligned}$$

Choosing an inductor value so that the ripple current is small will allow a maximum output current near the switch current limit.

One approach to choosing the inductor is to start with the simple rule given above, look at the available inductors and choose one to meet cost or space goals. Then use these equations to check that the LT1941 will be able to deliver the required output current. Note again that these equations assume that the inductor current is continuous. Discontinuous operation occurs when I_{OUT} is less than $\Delta I_L/2$.

Output Capacitor Selection

For 5V and 3.3V outputs, a 10 μ F, 6.3V ceramic capacitor (X5R or X7R) at the output results in very low output voltage ripple and good transient response. For lower voltages, 10 μ F is adequate for ripple requirements but increasing C_{OUT} will improve transient performance. Other types and values will also work; the following discusses tradeoffs in output ripple and transient performance.

The output capacitor filters the inductor current to generate an output with low voltage ripple. It also stores energy in order to satisfy transient loads and stabilize the LT1941's control loop. Because the LT1941 operates at a high frequency, minimal output capacitance is necessary. In addition, the control loop operates well with or without the presence of output capacitor series resistance (ESR). Ceramic capacitors, which achieve very low output ripple and small circuit size, are therefore an option.

APPLICATIONS INFORMATION

You can estimate output ripple with the following equations:

$$V_{\text{RIPPLE}} = \Delta I_L / (8 \cdot f \cdot C_{\text{OUT}}) \text{ for ceramic capacitors}$$

and

$$V_{\text{RIPPLE}} = \Delta I_L \cdot \text{ESR for electrolytic capacitors (tantalum and aluminum)}$$

where ΔI_L is the peak-to-peak ripple current in the inductor. The RMS content of this ripple is very low so the RMS current rating of the output capacitor is usually not of concern. It can be estimated with the formula:

$$I_{C(\text{RMS})} = \Delta I_L / \sqrt{12}$$

Another constraint on the output capacitor is that it must have greater energy storage than the inductor; if the stored energy in the inductor transfers to the output, the resulting voltage step should be small compared to the regulation voltage. For a 5% overshoot, this requirement indicates:

$$C_{\text{OUT}} > 10 \cdot L \cdot (I_{\text{LIM}}/V_{\text{OUT}})^2$$

The low ESR and small size of ceramic capacitors make them the preferred type for LT1941 applications. Not all ceramic capacitors are the same, however. Many of the higher value capacitors use poor dielectrics with high temperature and voltage coefficients. In particular, Y5V and Z5U types lose a large fraction of their capacitance with applied voltage and at temperature extremes. Because loop stability and transient response depend on the value of C_{OUT} , this loss may be unacceptable. Use X7R and X5R types.

Electrolytic capacitors are also an option. The ESRs of most aluminum electrolytic capacitors are too large to deliver low output ripple. Tantalum, as well as newer, lower-ESR organic electrolytic capacitors intended for power supply use are suitable. Chose a capacitor with a low enough ESR for the required output ripple. Because the volume of the capacitor determines its ESR, both the size and the value will be larger than a ceramic capacitor that would give similar ripple performance. One benefit is that the larger capacitance may give better transient response for large changes in load current. Table 2 lists several capacitor vendors.

Table 2. Low ESR Surface Mount Capacitors

VENDOR	TYPE	SERIES
Taiyo-Yuden	Ceramic	
AVX	Ceramic Tantalum	TPS
Kemet	Tantalum Tantalum Organic Aluminum Organic	T491, T494, T495 T520 A700
Sanyo	Tantalum or Aluminum Organic	POSCAP
Panasonic	Aluminum Organic	SP CAP
TDK	Ceramic	

Diode Selection

The catch diode (D1 from Figure 2) conducts current only during switch off time. Average forward current in normal operation can be calculated from:

$$I_{D(\text{AVG})} = I_{\text{OUT}} (V_{\text{IN}} - V_{\text{OUT}}) / V_{\text{IN}}$$

The only reason to consider a diode with a larger current rating than necessary for nominal operation is for the worst-case condition of shorted output. The diode current will then increase to the typical peak switch current.

Peak reverse voltage is equal to the regulator input voltage. Use a diode with a reverse voltage rating greater than the input voltage. Table 3 lists several Schottky diodes and their manufacturers.

Table 3. Schottky Diodes

PART NUMBER	V _R (V)	I _{AVE} (A)	V _F AT 1A (mV)	V _F AT 2A (mV)
On Semiconductor MBRM120E MBRM140	20 40	1 1	530 550	595
Diodes Inc. B120 B130 B220 B230	20 30 20 30	1 1 2 2	500 500	500 500
International Rectifier 10BQ030 20BQ030	30 30	1 2	420	470 470

APPLICATIONS INFORMATION

Boost Pin Considerations

The capacitor and diode tied to the BOOST pin generate a voltage that is higher than the input voltage. In most cases, a 0.18 μ F capacitor and fast switching diode (such as the CMDSH-3 or MMSD914LT1) will work well. Figure 3 shows four ways to arrange the boost circuit. The BOOST pin must be more than 2.5V above the SW pin for full efficiency. For outputs of 3.3V and higher, the standard circuit (Figure 3a) is best. For outputs between 2.8V and 3.3V, use a small Schottky diode (such as the BAT-54). For lower output voltages, the boost diode can be tied to the input (Figure 3b). The circuit in Figure 3a is more efficient because the boost pin current comes from a lower voltage source. Finally, as shown in Figure 3c, the anode of the boost diode can be tied to another source that is at least 3V. For example, if you are generating 3.3V and 1.8V and the 3.3V is on whenever the 1.8V is on, the 1.8V boost diode can be connected to the 3.3V output. In any case, be sure that the maximum voltage at the BOOST pin is less than 35V and the voltage difference between the BOOST and SW pins is less than 25V.

The boost circuit can also run directly from a DC voltage that is higher than the input voltage by more than 2.5V + V_F , as in Figure 3d. The diode prevents damage to the LT1941

in case V_{IN2} is held low while V_{IN} is present. The circuit saves several components (both BOOST pins can be tied to D2). However, efficiency may be lower and dissipation in the LT1941 may be higher. Also, if V_{IN2} is absent the LT1941 will still attempt to regulate the output, but will do so with low efficiency and high dissipation because the switch will not be able to saturate, dropping 1.5V to 2V in conduction.

The minimum operating voltage of an LT1941 application is limited by the undervoltage lockout (3.5V) and by the maximum duty cycle. The boost circuit also limits the minimum input voltage for proper start-up. If the input voltage ramps slowly, or the LT1941 turns on when the output is already in regulation, the boost capacitor may not be fully charged. Because the boost capacitor charges with the energy stored in the inductor, the circuit will rely on some minimum load current to get the boost circuit running properly. This minimum load will depend on input and output voltages, and on the arrangement of the boost circuit. The minimum load current generally goes to zero once the circuit has started. Even without an output load current, in many cases the discharged output capacitor will present a load to the switcher that will allow it to start.

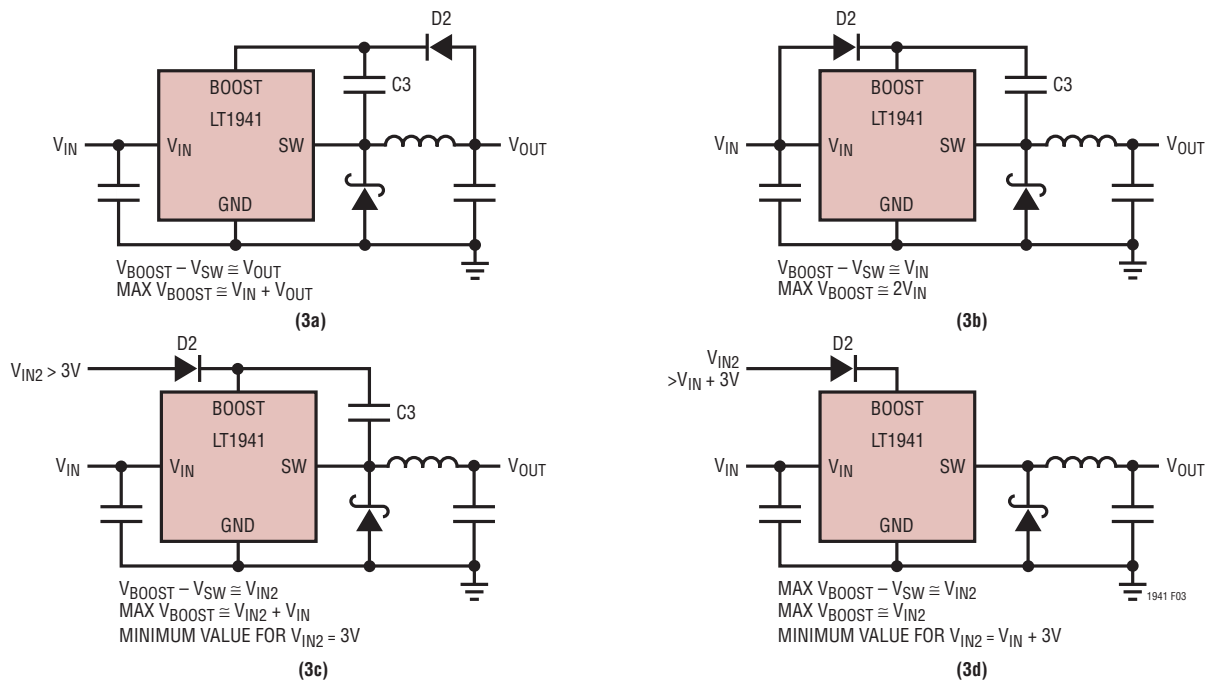

Figure 3. Generating the Boost Voltage

APPLICATIONS INFORMATION

Converter with Backup Output Regulator

There is another situation to consider in systems where the output will be held high when the input to the LT1941 is absent. If the V_{IN} and one of the RUN/SS pins are allowed to float, then the LT1941's internal circuitry will pull its quiescent current through its SW pin. This is acceptable if the system can tolerate a few mA of load in this state. With both RUN/SS pins grounded, the LT1941 enters shutdown mode and the SW pin current drops to ~50mA. However, if the V_{IN} pin is grounded while the output is held high, then parasitic diodes inside the LT1941 can pull large currents from the output through the SW pin and the V_{IN} pin. A Schottky diode in series with the input to the LT1941, as shown in Figure 4, will protect the LT1941 and the system from a shorted or reversed input.

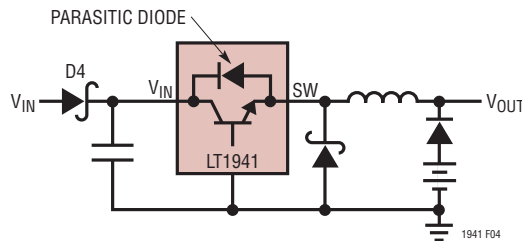

Figure 4. Diode D4 Prevents a Shorted Input from Discharging a Backup Battery Tied to the Output

INVERTER/BOOST CONSIDERATIONS

Regulating Positive Output Voltages

The output voltage is programmed with a resistor divider between the output and the FB pin. Choose the resistors according to:

$$R3 = R4 \left(\frac{V_{OUT}}{1.25V} - 1 \right)$$

R4 should be 10k or less to avoid bias current errors.

NFB should be tied to FB3.

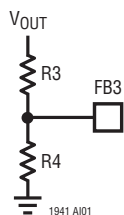

Regulating Negative Output Voltages

The LT1941 contains an inverting op-amp with its noninverting terminal tied to ground and its output connected to the FB3 pin. Use this op-amp to generate a voltage at FB3 that is proportional to V_{OUT} . Choose the resistors according to:

$$R4 = \frac{R3 \cdot |V_{OUT}|}{1.24V}$$

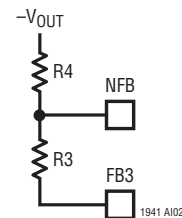

Use 10k or larger, up to 20k for R3.

Duty Cycle Range

The maximum duty cycle (DC) of the LT1941 inverter/boost regulator is 77%. The duty cycle for a given application using the inverting topology is:

$$DC = \frac{|V_{OUT}|}{V_{IN} + |V_{OUT}|}$$

The duty cycle for a given application using the boost topology is:

$$DC = \frac{V_{OUT} - V_{IN}}{V_{OUT}}$$

The LT1941 can still be used in applications where the DC, as calculated above, is above 77%; however, the part must be operated in discontinuous mode so that the actual duty cycle is reduced.

Inductor Selection

Several inductors that work well with the LT1941 inverter/boost regulator are listed in Table 4. Besides these, many other inductors will work. Consult each manufacturer for detailed information and for their entire selection of related parts. Use ferrite core inductors to obtain the best efficiency. When using coupled inductors, choose one that

APPLICATIONS INFORMATION

can handle at least 1.5A of current without saturating and ensure that the inductor has a low DCR (copper-wire resistance) to minimize I^2R power losses. If using uncoupled inductors, each inductor need only handle one-half of the total switch current so that 0.75A per inductor is sufficient. A 4.7 μ H to 15 μ H coupled inductor or two 15 μ H to 20 μ H uncoupled inductors will usually be the best choice for most LT1941 inverter designs. A 4.7 μ H to 15 μ H inductor will be the best choice for most LT1941 boost designs. In this case, the single inductor must carry the entire 1.5A peak switch current.

Table 4. Inductors

PART NUMBER	VALUE (μ H)	$I_{SAT(DC)}$ (A)	DCR (Ω)	HEIGHT (mm)
Coiltronics				
TP3-4R7	4.7	1.5	0.181	2.2
TP4-100	10	1.5	0.146	3.0
Sumida				
CDRH6D38NP-6R2	6.2	2.5	20m	3.8
CDRH6D38NP-7R4	7.4	2.3	23m	3.8
CDRH6D38NP-100	10	2.0	28m	3.8

Output Capacitor Selection

Use low ESR (equivalent series resistance) capacitors at the output to minimize the output ripple voltage. Multilayer ceramic capacitors are an excellent choice; they have an extremely low ESR and are available in very small packages. X7R dielectrics are preferred, followed by X5R, as these materials retain their capacitance over wide voltage and temperature ranges. A 4.7 μ F to 20 μ F output capacitor is sufficient for most LT1941 applications. Solid tantalum or OS-CON capacitors will work but they will occupy more board area and will have a higher ESR than a ceramic capacitor. Always use a capacitor with a sufficient voltage rating.

Diode Selection

A Schottky diode is recommended for use with the LT1941 inverter/boost regulator. The Microsemi UPS120 is a very good choice. Where the input to output voltage differential

exceeds 20V, use the UPS140 (a 40V diode). These diodes are rated to handle an average forward current of 1A. For applications where the average forward current of the diode is less than 0.5A, use an ON Semiconductor MBR0520L diode. The load current for boost, SEPIC and inverting configurations is equal to the average diode current.

BIAS2 Pin Considerations

The BIAS2 pin provides the drive current for the inverter/boost switch. The voltage source on the BIAS2 line should be able to supply the rated current and be at a minimum of 2.5V. For highest efficiency, use the lowest voltage source possible ($V_{OUT} = 3.3V$, for example) to minimize the $V_{BIAS2} \cdot I_{BIAS2}$ power loss inside the part.

INPUT CAPACITOR SELECTION

Bypass the input of the LT1941 circuit with a 10 μ F or higher ceramic capacitor of X7R or X5R type. A lower value or a less expensive Y5V type will work if there is additional bypassing provided by bulk electrolytic capacitors, or if the input source impedance is low. The following paragraphs describe the input capacitor considerations in more detail.

Step-down regulators draw current from the input supply in pulses with very fast rise and fall times. The input capacitor is required to reduce the resulting voltage ripple at the LT1941 input and to force this switching current into a tight local loop, minimizing EMI. The input capacitor must have low impedance at the switching frequency to do this effectively and it must have an adequate ripple current rating. With two switchers operating at the same frequency but with different phases and duty cycles, calculating the input capacitor RMS current is not simple; however, a conservative value is the RMS input current for the channel that is delivering the most power (V_{OUT} times I_{OUT}):

$$C_{IN(RMS)} = I_{OUT} \cdot \frac{\sqrt{V_{OUT}(V_{IN} - V_{OUT})}}{V_{IN}} < \frac{I_{OUT}}{2}$$

APPLICATIONS INFORMATION

and is largest when $V_{IN} = 2 V_{OUT}$ (50% duty cycle). As the second, lower power channel draws input current, the input capacitor's RMS current actually decreases as the out-of-phase current cancels the current drawn by the higher power channel. The ripple current contribution from the third channel will be minimal. Considering that the maximum load current from a single channel is $\sim 2.8A$, RMS ripple current will always be less than 1.4A.

The high frequency of the LT1941 reduces the energy storage requirements of the input capacitor, so that the capacitance required is often less than $10\mu F$. The combination of small size and low impedance (low equivalent series resistance or ESR) of ceramic capacitors makes them the preferred choice. The low ESR results in very low voltage ripple. Ceramic capacitors can handle larger magnitudes of ripple current than other capacitor types of the same value. Use X5R and X7R types.

An alternative to a high value ceramic capacitor is a lower value along with a larger electrolytic capacitor, for example a $1\mu F$ ceramic capacitor in parallel with a low ESR tantalum capacitor. For the electrolytic capacitor, a value larger than $10\mu F$ will be required to meet the ESR and ripple current requirements. Because the input capacitor is likely to see high surge currents when the input source is applied, tantalum capacitors should be surge rated. The manufacturer may also recommend operation below the rated voltage of the capacitor. Be sure to place the $1\mu F$ ceramic as close as possible to the V_{IN} and GND pins on the IC for optimal noise immunity.

A final caution is in order regarding the use of ceramic capacitors at the input. A ceramic input capacitor can combine with stray inductance to form a resonant tank circuit. If power is applied quickly (for example by plugging the circuit into a live power source), this tank can ring, doubling the input voltage and damaging the LT1941. The solution is to either clamp the input voltage or dampen the tank circuit by adding a lossy capacitor in parallel with the ceramic capacitor. For details, see Application Note 88.

Frequency Compensation

The LT1941 uses current mode control to regulate the output. This simplifies loop compensation. In particular, the

LT1941 does not depend on the ESR of the output capacitor for stability so you are free to use ceramic capacitors to achieve low output ripple and small circuit size.

The components tied to the V_C pin provide frequency compensation. Generally, a capacitor and a resistor in series to ground determine loop gain. In addition, there is a lower value capacitor in parallel. This capacitor filters noise at the switching frequency and is not part of the loop compensation.

Loop compensation determines the stability and transient performance. Designing the compensation network is a bit complicated and the best values depend on the application and the type of output capacitor. A practical approach is to start with one of the circuits in this data sheet that is similar to your application and tune the compensation network to optimize the performance. Check stability across all operating conditions, including load current, input voltage and temperature. The LT1375 data sheet contains a more thorough discussion of loop compensation and describes how to test the stability using a transient load. Application Note 76 is an excellent source as well.

Figure 5 shows an equivalent circuit for the LT1941 control loop. The error amp is a transconductance amplifier with finite output impedance. The power section, consisting of the modulator, power switch and inductor is modeled as a transconductance amplifier generating an output current proportional to the voltage at the V_C pin. Note that the output capacitor integrates this current and that the capacitor on the V_C pin (C_C) integrates the error amplifier output current, resulting in two poles in the loop. In most cases, a zero is required and comes either from the output capacitor ESR or from a resistor in series with C_C . This model works well as long as the inductor current ripple is not too low ($\Delta I_{RIPPLE} > 5\% I_{OUT}$) and the loop crossover frequency is less than $f_{SW}/5$. A phase lead capacitor (C_{PL}) across the feedback divider may improve the transient response.

The equivalent circuit for the LT1941 inverter control loop is slightly different than is shown in Figure 5. The feedback resistors are connected as shown for negative outputs in Figure 2. The operational amplifier is fast enough to have minimal effect on the loop dynamics.

APPLICATIONS INFORMATION

Table 5. Converter Equivalent Model Parameters

	STEP-DOWN1	STEP-DOWN2	BOOST	INVERTER
V_{FB}	0.628V	0.628V	1.25	1.24
R_O	500k Ω	500k Ω	500k Ω	500k Ω
g_{ma}	1700 μ mho	1700 μ mho	800 μ mho	800 μ mho
g_{mp}	5mho	3.6mho	$\frac{V_{IN} \cdot 5\text{mho}}{V_{OUT}}$	$\frac{V_{IN} \cdot 5\text{mho}}{- V_{OUT} }$

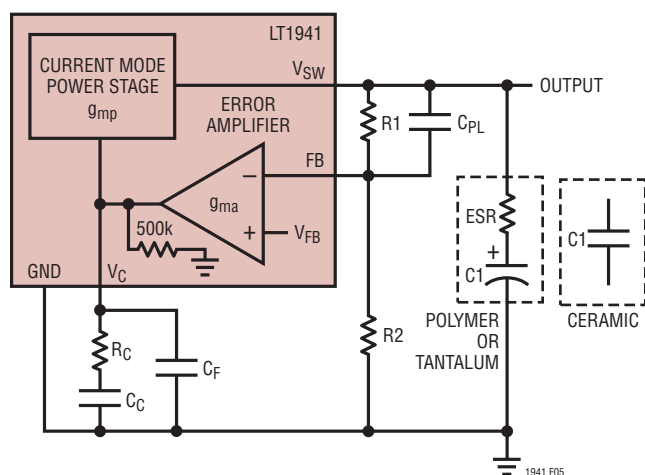

Figure 5. Model for Loop Response

SOFT-START AND SHUTDOWN

The RUN/SS (Run/Soft-Start) pins are used to place the individual switching regulators and the internal bias circuits in shutdown mode. They also provide a soft-start function. To shut down a regulator, pull its RUN/SS pin to ground with an open drain or collector. If all three RUN/SS pins are pulled to ground, the LT1941 enters its shutdown mode with all regulators off and quiescent current reduced to ~50mA. Internal 2 μ A current sources pull up on each pin. If any RUN/SS pin reaches ~0.6V, the internal bias circuits start and the quiescent currents increase to their nominal levels.

If a capacitor is tied from the RUN/SS pin to ground, then the internal pull-up current will generate a voltage ramp on this pin. This voltage clamps the V_C pin, limiting the peak switch current and therefore input current during start-up. A good value for the soft-start capacitor is $C_{OUT}/10,000$, where C_{OUT} is the value of the output capacitor.

The RUN/SS pins can be left floating if the shutdown feature is not used. They can also be tied together with a

single capacitor providing soft-start. The internal current sources will charge these pins to ~2V.

The RUN/SS pins provide a soft-start function that limits peak input current to the circuit during start-up. This helps to avoid drawing more current than the input source can supply or glitching the input supply when the LT1941 is enabled. The RUN/SS pins do not provide an accurate delay to start or an accurately controlled ramp at the output voltage, both of which depend on the output capacitance and the load current. However, the power good indicators can be used to sequence the three outputs, as described below.

POWER GOOD INDICATORS

The PGOOD pin is the open-collector output of an internal comparator. PGOOD remains low until the FB pin is within 10% of the final regulation voltage. Tie the PGOOD to any supply with a pull-up resistor that will supply less than 200 μ A. Note that this pin will be open when the LT1941 is in shutdown mode (all three RUN/SS pins at ground) regardless of the voltage at the FB pin. PGOOD is valid when the LT1941 is enabled (any RUN/SS pin is high) and V_{IN} is greater than ~3.5V.

The 5GOOD and 12GOOD pins are also open-collector outputs of internal comparators. The 5GOOD pin remains low until the input is within 10% of 5V. Tie the 5GOOD and 12GOOD pins to any supply with a pull-up resistor that will supply less than 100 μ A. The 12GOOD pin remains low until the input is within 10% of 12V. The 5GOOD and 12GOOD pins are valid as long as V_{IN} is greater than 1.1V. Both the 5GOOD and 12GOOD pins will sink current when the part is in shutdown, independent of the voltage at V_{IN} .

Output Sequencing

The PG and RUN/SS pins can be used to sequence the three outputs. Figure 6 shows several circuits to do this. The techniques shown to sequence two channels can be extended to sequence the third. In each case channel 1 starts first. Note that these circuits sequence the outputs during start-up. When shut down the three channels turn off simultaneously.

APPLICATIONS INFORMATION

In Figure 6a, a larger capacitor on RUN/SS2 delays channel 2 with respect to channel 1. The soft-start capacitor on RUN/SS2 should be at least twice the value of the capacitor on RUN/SS1. A larger ratio may be required, depending on the output capacitance and load on each channel. Make sure to test the circuit in the system before deciding on final values for these capacitors.

The circuit in Figure 6b requires the fewest components, with both channels sharing a single soft-start capacitor. The power good comparator of channel 1 disables channel 2 until output 1 is in regulation.

For independent control of channel 2, use the circuit in Figure 6c. The capacitor on RUN/SS1 is smaller than the capacitor on RUN/SS2. This allows the LT1941 to start up and enable its power good comparator before RUN/SS2 gets high enough to allow channel 2 to start switching. Channel 2 only operates when it is enabled with the external control signals and output 1 is in regulation.

The circuit in Figure 6a leaves both power good indicators free. However, the circuits in Figures 6b and 6c have another advantage. As well as sequencing the two outputs at start-up, they also disable channel 2 if output 1 falls out of regulation (due to a short circuit or a collapsing input voltage).

Finally, be aware that **the circuit in Figure 6d does not work**, because the power good comparators are disabled in shutdown.

PCB LAYOUT

For proper operation and minimum EMI, care must be taken during printed circuit board (PCB) layout. Figure 7 shows the high current paths in the step-down regulator circuit. Note that in the step-down regulators large, switched currents flow in the power switch, the catch diode and the input capacitor. In the inverter/boost regulator large, switched currents flow through the power switch, the switching diode, and either the output capacitor in boost configuration, or the tank capacitor in the inverter configuration. The loop formed by these components should be as small as possible. Place these components, along with the inductor and output capacitor, on the same side of the circuit board and connect them on that layer. Place a local, unbroken ground plane below these components and tie this ground plane to system ground at one location, ideally at the ground terminal of the output capacitor C2. Additionally, keep the SW and BOOST nodes as small as possible.

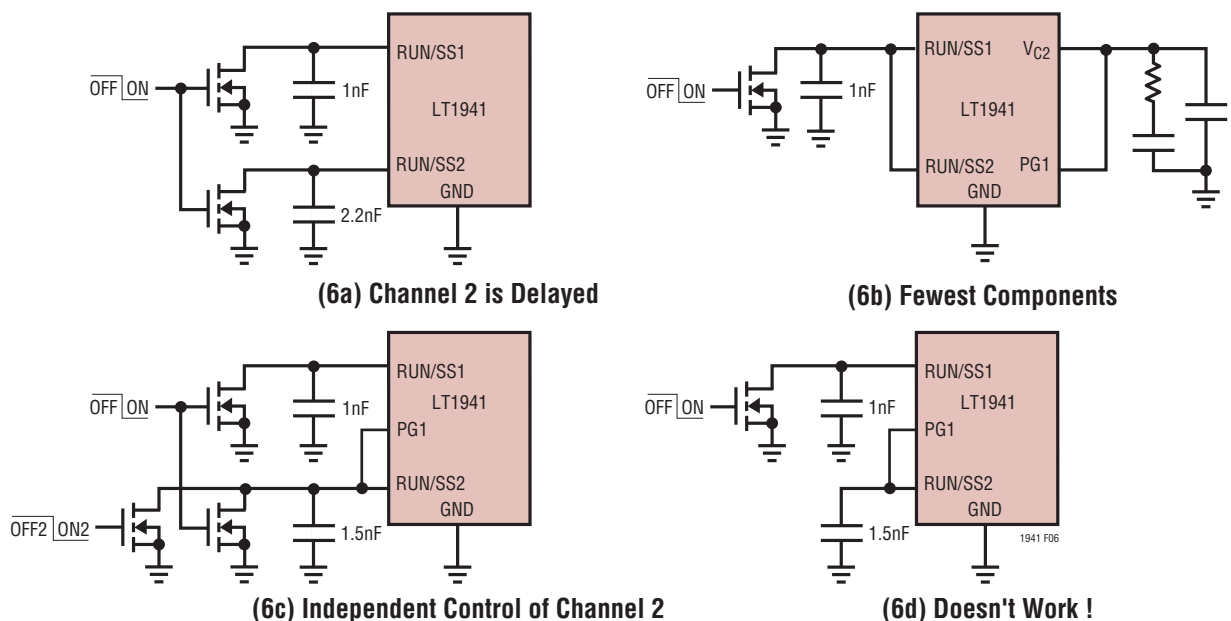

Figure 6. Several Methods of Sequencing Two Outputs. Channel 1 Starts First

APPLICATIONS INFORMATION

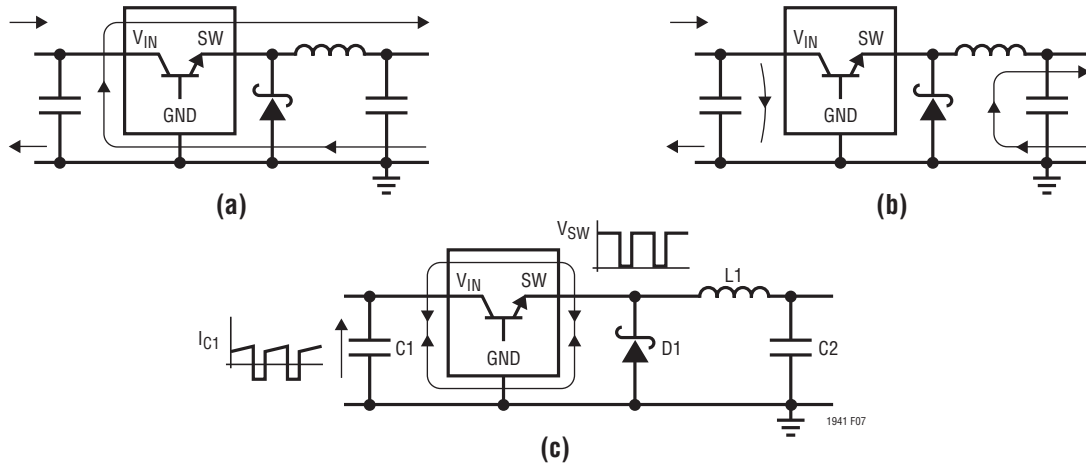

Figure 7. Subtracting the Current when the Switch is ON (a) From the Current when the Switch is OFF (b) Reveals the Path of the High Frequency Switching Current (c) Keep This Loop Small. The Voltage on the SW and BOOST Nodes will also be Switched; Keep these Nodes as Small as Possible. Finally, Make Sure the Circuit is Shielded with a Local Ground Plane

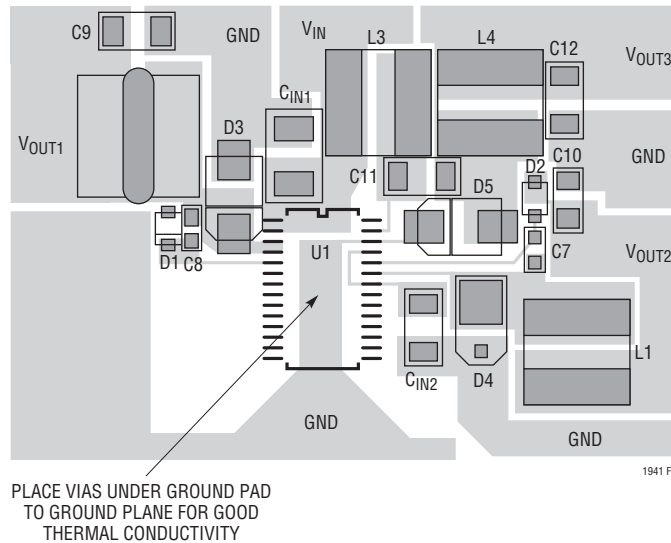

Figure 8. Power Path Components and Topside Layout

THERMAL CONSIDERATIONS

The PCB must provide heat sinking to keep the LT1941 cool. The Exposed Pad on the bottom of the package must be soldered to a ground plane. This ground should be tied to other copper layers below with thermal vias; these layers will spread the heat dissipated by the LT1941. Place additional vias near the catch diodes. Adding more copper to the top and bottom layers and tying this copper to the internal planes with vias can reduce thermal resistance further. With these steps, the thermal resistance from die

(or junction) to ambient can be reduced to $\theta_{JA} = 25^{\circ}\text{C}/\text{W}$ or less. With 100 LFPM airflow, this resistance can fall by another 25%. Further increases in airflow will lead to lower thermal resistance.

Because of the large output current capability of the LT1941, it is possible to dissipate enough heat to raise the junction temperature beyond the absolute maximum of 125°C . If two of the channels are running at full output current, the third channel may have reduced output current capability, limited by the maximum junction temperature. The output

1941fb

APPLICATIONS INFORMATION

current capability of the third channel can be calculated from the output currents and voltages of the other channels, the switching regulator efficiency (η), the ambient temperature (T_A), the maximum junction temperature (T_{JMAX}) and the thermal resistance from junction to ambient (θ_{JA}) as follows:

$$P_{DISS} = \frac{T_{JMAX} - T_A}{\theta_{JA}}$$

$$P_3 = \frac{P_{DISS}}{1 - \eta} - V_1 \cdot I_1 - V_2 \cdot I_2$$

$$I_3 = \frac{P_3}{V_3}$$

Example: LT1941 at $V_1 = 2.5V$, $I_1 = 2A$, $V_2 = 3.3V$, $I_2 = 1A$, $V_3 = 12V$, $\eta = 80\%$, $T_A = 75^\circ C$, $T_{JMAX} = 125^\circ C$, $\theta_{JA} = 25^\circ C/W$:

$$P_{DISS} = \frac{125^\circ C - 75^\circ C}{25^\circ C/W} = 2W$$

$$P_3 = \frac{2W}{1 - 0.8} - 2.5V \cdot 2A - 3.3V \cdot 1A = 1.7W$$

$$I_3 = \frac{1.7W}{12V} = 0.141A$$

Note that decreasing θ_{JA} increases the power output capability. The power output capability of the individual channels can be calculated from the following:

$$\text{Channel 1 Output Power (P1)} = V_1 \cdot I_1$$

$$\text{Channel 2 Output Power (P2)} = V_2 \cdot I_2$$

$$\text{Channel 3 Output Power (P3)} = V_3 \cdot I_3$$

$$\text{Total Output Power (P123)} = P_{DISS}/\eta = P_1 + P_2 + P_3$$

Figure 9 shows power output capability if overall system efficiency (η) is 75% and maximum allowable power dissipation (P_{DISS}) is either 1W or 2W. For example, if allowable power dissipation is 2W, Channel 3 output power is 2W and Channel 2 output power is 1W, then Channel 1 output power can be up to 5W.

RELATED LINEAR TECHNOLOGY PUBLICATIONS

Application notes 19, 35, 44, 76 and 88 contain more detailed descriptions and design information for buck regulators and other switching regulators. The LT1375 data sheet has a more extensive discussion of output ripple, loop compensation, and stability testing. Design Notes 100 and 318 show how to generate a dual polarity output supply using a buck regulator.

Power Output Capability for $P_{DISS} = 2W$, $\eta = 0.75$

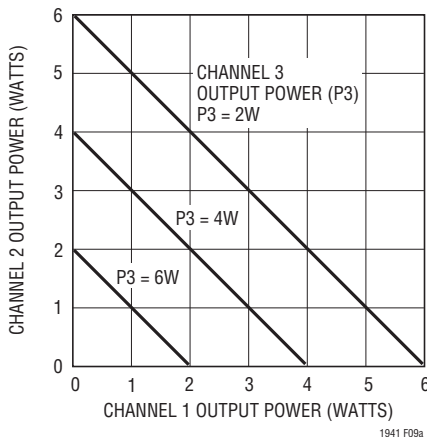

Power Output Capability for $P_{DISS} = 1W$, $\eta = 0.75$

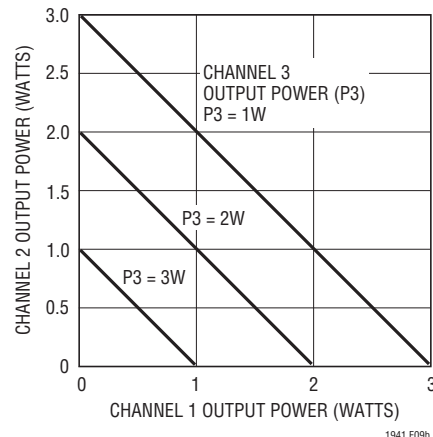
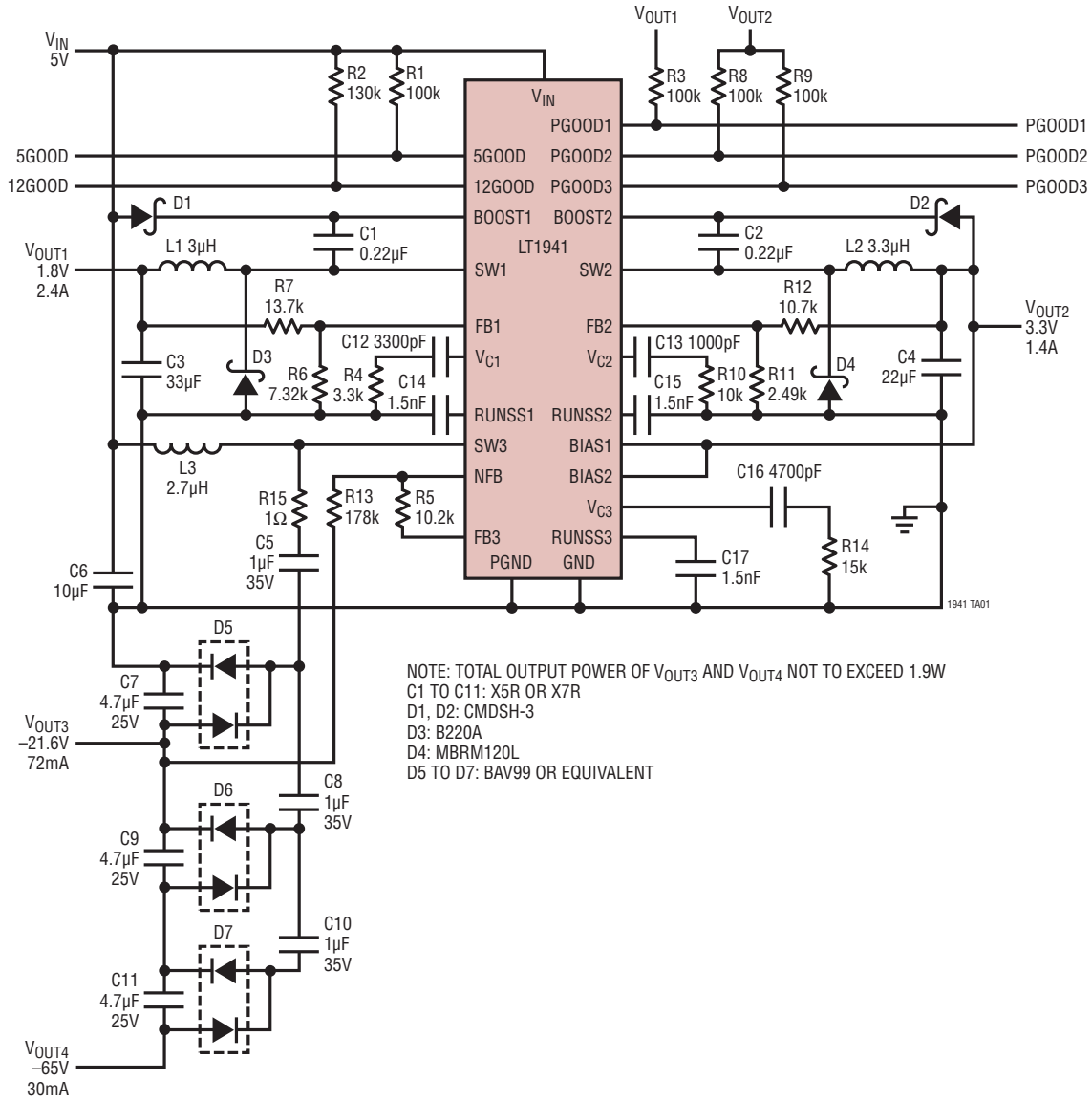

Figure 9. Power Output Capability of an Individual Channel Depends on the Output Power of the Other Channels

APPLICATIONS INFORMATION

SLIC Power Supply
-21.6V, -65V, 3.3V and 1.8V with Soft-Start



TYPICAL APPLICATIONS

Quadruple Output Power Supply:
±12V, 3.3V and 2.5V with Soft-Start

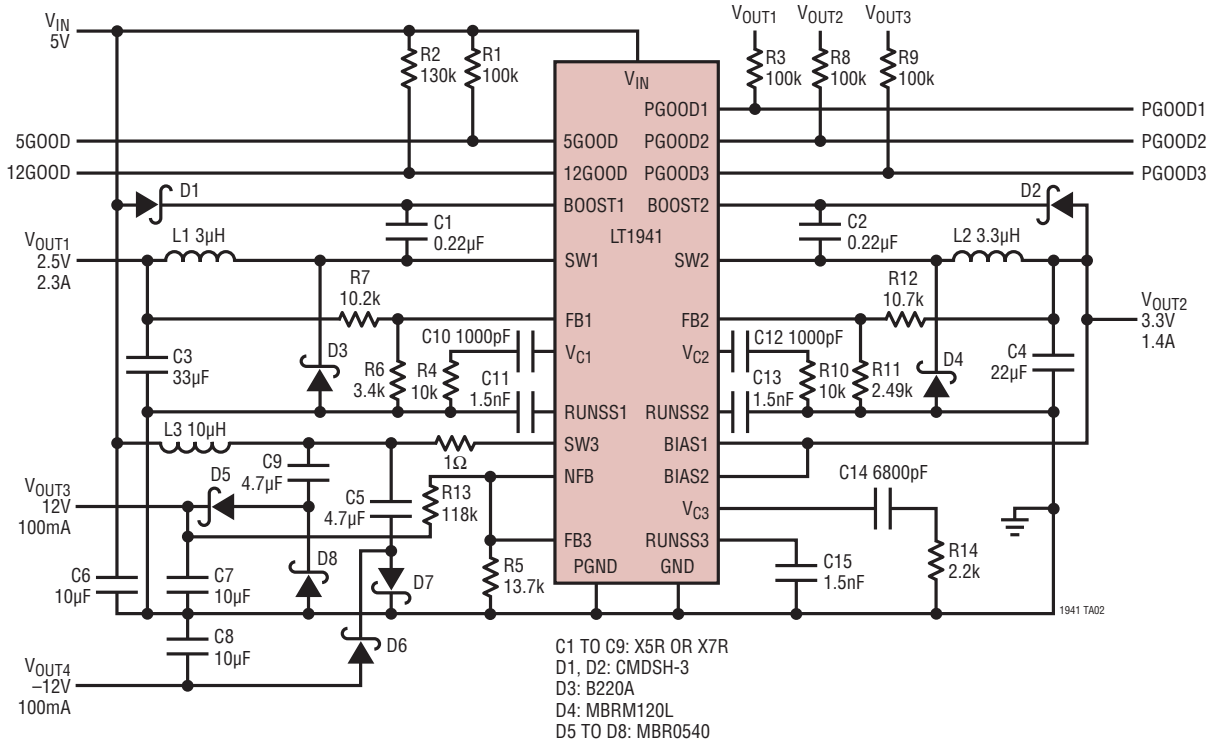

Triple Output Power Supply: 3.3V, 1.8V and -12V

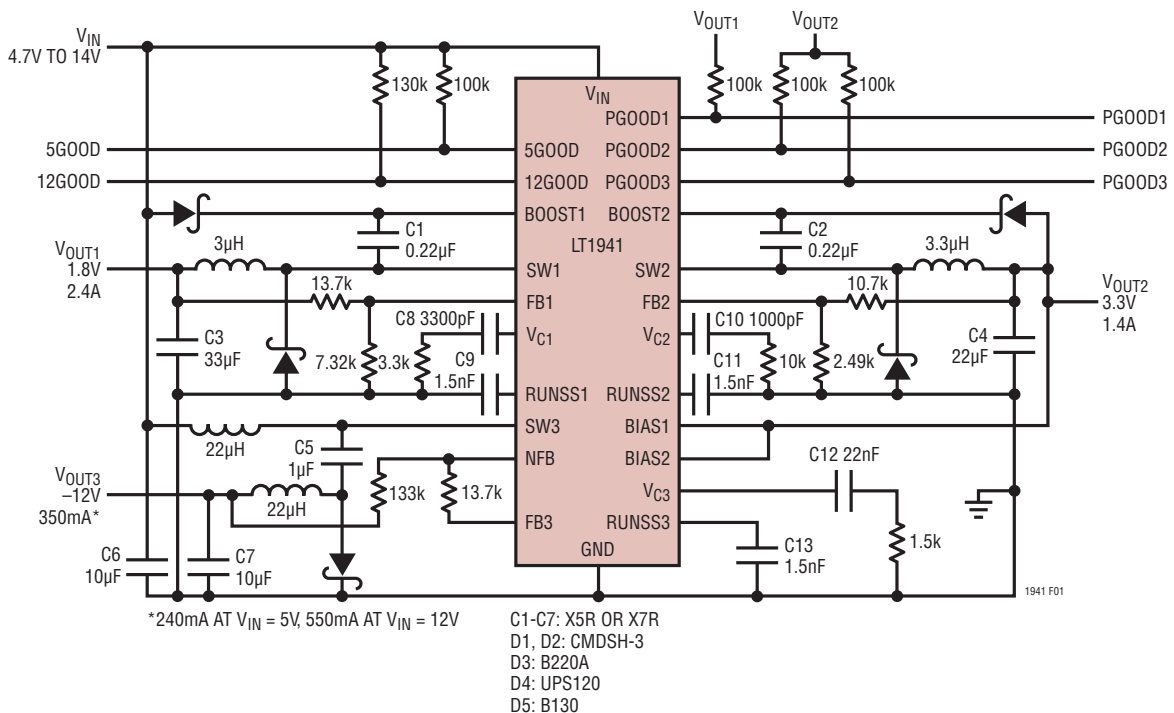

PACKAGE DESCRIPTION

FE Package
28-Lead Plastic TSSOP (4.4mm)
 (Reference LTC DWG # 05-08-1663)
Exposed Pad Variation EB

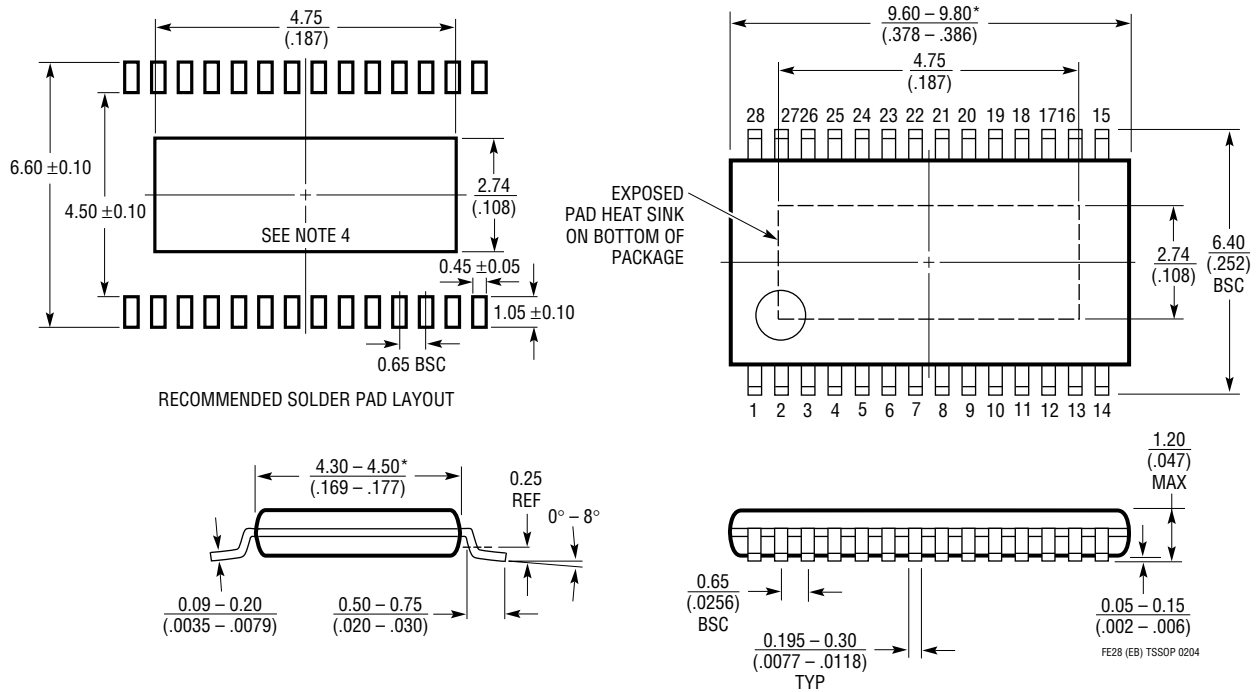

- NOTE:
1. CONTROLLING DIMENSION: MILLIMETERS
 2. DIMENSIONS ARE IN MILLIMETERS (INCHES)
 3. DRAWING NOT TO SCALE
 4. RECOMMENDED MINIMUM PCB METAL SIZE FOR EXPOSED PAD ATTACHMENT
- *DIMENSIONS DO NOT INCLUDE MOLD FLASH. MOLD FLASH SHALL NOT EXCEED 0.150mm (.006") PER SIDE

FE28 (EB) TSSOP 0204

RELATED PARTS

PART NUMBER	DESCRIPTION	COMMENTS
LT1613	550mA (I_{SW}), 1.4MHz, High Efficiency Step-Up DC/DC Converter	V_{IN} : 0.9V to 10V, $V_{OUT(MAX)}$ = 34V, I_Q = 3mA, I_{SD} < 1 μ A, ThinSOT™ Package
LT1615/LT1615-1	300mA/80mA (I_{SW}), High Efficiency Step-Up DC/DC Converter	V_{IN} : 1V to 15V, $V_{OUT(MAX)}$ = 34V, I_Q = 20 μ A, I_{SD} < 1 μ A, ThinSOT Package
LT1617/LT1617-1	300mA/100mA (I_{SW}), 1.2MHz/2.2MHz, High Efficiency Inverting DC/DC Converter	V_{IN} : 1.2V to 15V, $V_{OUT(MAX)}$ = -34V, I_Q = 20 μ A, I_{SD} < 1 μ A, ThinSOT Package
LT1618	1.5A (I_{SW}), 1.25MHz, High Efficiency Step-Up DC/DC Converter	V_{IN} : 1.6V to 18V, $V_{OUT(MAX)}$ = 35V, I_Q = 1.8mA, I_{SD} < 1 μ A, MS10 Package
LT1930/LT1930A	1A (I_{SW}), 1.2MHz/2.2MHz, High Efficiency Step-Up DC/DC Converter	V_{IN} : 2.6V to 16V, $V_{OUT(MAX)}$ = 34V, I_Q = 4.2mA/5.5mA, I_{SD} < 1 μ A, ThinSOT Package
LT1931/LT1931A	1A (I_{SW}), 1.2MHz/2.2MHz, High Efficiency Inverting DC/DC Converter	V_{IN} : 2.6V to 16V, $V_{OUT(MAX)}$ = -34V, I_Q = 5.8mA, I_{SD} < 1 μ A, ThinSOT Package
LT1943	Quad Output, 2.6A Buck, 2.6A Boost, 0.3A Boost, 0.4A Inverter 1.2MHz TFT DC/DC Converter	V_{IN} : 4.5V to 22V, $V_{OUT(MAX)}$ = 40V, I_Q = 10mA, I_{SD} < 35 μ A, TSSOP28E Package
LT1944-1	Dual Output 150mA (I_{SW}), Constant Off-Time, High Efficiency Step-Up DC/DC Converter	V_{IN} : 1.2V to 15V, $V_{OUT(MAX)}$ = 34V, I_Q = 20 μ A, I_{SD} < 1 μ A, MS10 Package
LT1944	Dual Output 350mA (I_{SW}), Constant Off-Time, High Efficiency Step-Up DC/DC Converter	V_{IN} : 1.2V to 15V, $V_{OUT(MAX)}$ = 34V, I_Q = 20 μ A, I_{SD} < 1 μ A, MS10 Package
LT1945	Dual Output Pos/Neg 350mA (I_{SW}), Constant Off-Time, High Efficiency Step-Up DC/DC Converter	V_{IN} : 1.2V to 15V, $V_{OUT(MAX)}$ = \pm 34V, I_Q = 20 μ A, I_{SD} < 1 μ A, MS10 Package
LT1946/LT1946A	1.5A (I_{SW}), 1.2MHz/2.7MHz, High Efficiency Step-Up DC/DC Converter	V_{IN} : 2.45V to 16V, $V_{OUT(MAX)}$ = 34V, I_Q = 3.2mA, I_{SD} < 1 μ A, MS8 Package
LT1961	1.5A (I_{SW}), 1.25MHz, High Efficiency Step-Up DC/DC Converter	V_{IN} : 3V to 25V, $V_{OUT(MAX)}$ = 35V, I_Q = 0.9mA, I_{SD} < 6 μ A, MS8E Package
LT3436	3A (I_{SW}), 1MHz, 34V Step-Up DC/DC Converter	V_{IN} : 3V to 25V, $V_{OUT(MAX)}$ = 34V, I_Q = 0.9mA, I_{SD} < 6 μ A, TSSOP16E Package
LT3461/LT3461A	300mA (I_{SW}), High Efficiency Step-Up DC/DC Converter with Integrated Schottky and Soft-Start	V_{IN} : 2.5V to 16V, $V_{OUT(MAX)}$ = 38V, I_Q = 2.8mA, I_{SD} < 1 μ A, ThinSOT Package
LT3463	Dual Output Pos/Neg 250mA (I_{SW}), Constant Off-Time, High Efficiency Step-Up DC/DC Converter with Integrated Schottkys	V_{IN} : 2.4V to 15V, $V_{OUT(MAX)}$ = \pm 40V, I_Q = 40 μ A, I_{SD} < 1 μ A, 3mm \times 3mm DFN10 Package
LT3464	85mA (I_{SW}), High Efficiency Step-Up DC/DC Converter with Integrated Schottky and PNP Disconnect	V_{IN} : 2.3V to 10V, $V_{OUT(MAX)}$ = 34V, I_Q = 25 μ A, I_{SD} < 1 μ A, ThinSOT Package

ThinSOT is a trademark of Linear Technology Corporation.