

# 80V<sub>IN</sub>, 80V<sub>OUT</sub> Constant-Current, Constant-Voltage Converter

## FEATURES

- 3000:1 True Color PWM™ Dimming
- Wide Input Voltage Range: 4.5V to 80V
- Output Voltage Up to 80V
- Internal 3.3A/84V Switch
- Constant-Current and Constant-Voltage Regulation
- 250mV High Side Current Sense
- Drives LEDs in Boost, Buck Mode, Buck-Boost Mode, SEPIC or Flyback Topology
- Adjustable Frequency: 100kHz to 1MHz
- Open LED Protection
- Programmable Undervoltage Lockout with Hysteresis
- Constant-Voltage Loop Status Pin
- PWM Disconnect Switch Driver
- CTRL Pin Adjusts High Side Current Sense Threshold
- Low Shutdown Current: <1μA
- Programmable Soft-Start
- Available in the 36-Lead (5mm × 6mm) QFN Package

## APPLICATIONS

- High Power LED
- Battery Charger
- Accurate Current Limited Voltage Regulator

## DESCRIPTION

The LT<sup>®</sup>3956 is a DC/DC converter designed to operate as a constant-current source and constant-voltage regulator. It is ideally suited for driving high current LEDs. It features an internal low side N-channel power MOSFET rated for 84V at 3.3A and driven from an internal regulated 7.15V supply. The fixed frequency, current-mode architecture results in stable operation over a wide range of supply and output voltages. A ground referenced voltage FB pin serves as the input for several LED protection features, and also makes it possible for the converter to operate as a constant-voltage source. A frequency adjust pin allows the user to program the frequency from 100kHz to 1MHz to optimize efficiency, performance or external component size.

The LT3956 senses output current at the high side of the LED string. High side current sensing is the most flexible scheme for driving LEDs, allowing boost, buck mode or buck-boost mode configuration. The PWM input provides LED dimming ratios of up to 3000:1, and the CTRL input provides additional analog dimming capability.

LT, LT, LTC, LTM, Linear Technology and the Linear logo are registered trademarks and True Color PWM is a trademark of Linear Technology Corporation. All other trademarks are the property of their respective owners. Protected by U.S. Patents, including 7199560 and 7321203.

## TYPICAL APPLICATION

94% Efficient 25W White LED Headlamp Driver

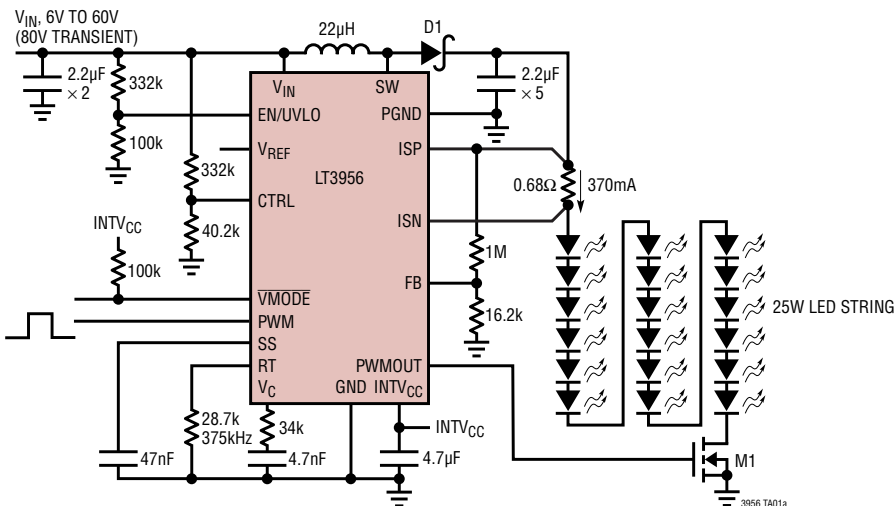

Efficiency vs V<sub>IN</sub>

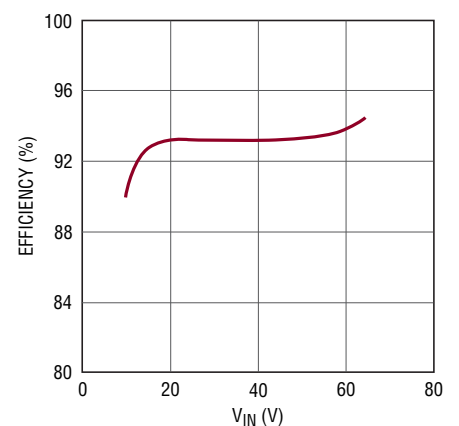

3956 TA01b

3956f

## ABSOLUTE MAXIMUM RATINGS

(Note 1)

$V_{IN}$ , ISP, ISN .....	80V
SW .....	84V
EN/UVLO (Note 3) .....	80V
INTV <sub>CC</sub> .....	$V_{IN} + 0.3V$ , 8V
PWMOUT .....	INTV <sub>CC</sub> + 0.3V
CTRL, PWM, V <sub>MODE</sub> .....	12V
FB .....	8V
$V_C$ , $V_{REF}$ , SS .....	3V
RT .....	1.5V
PGND to GND .....	±0.5V
Operating Junction Temperature Range (Note 2) .....	-40°C to 125°C
Maximum Junction Temperature .....	125°C
Storage Temperature Range .....	-65°C to 125°C
Lead Temperature (Soldering, 10 sec) .....	300°C

## PIN CONFIGURATION

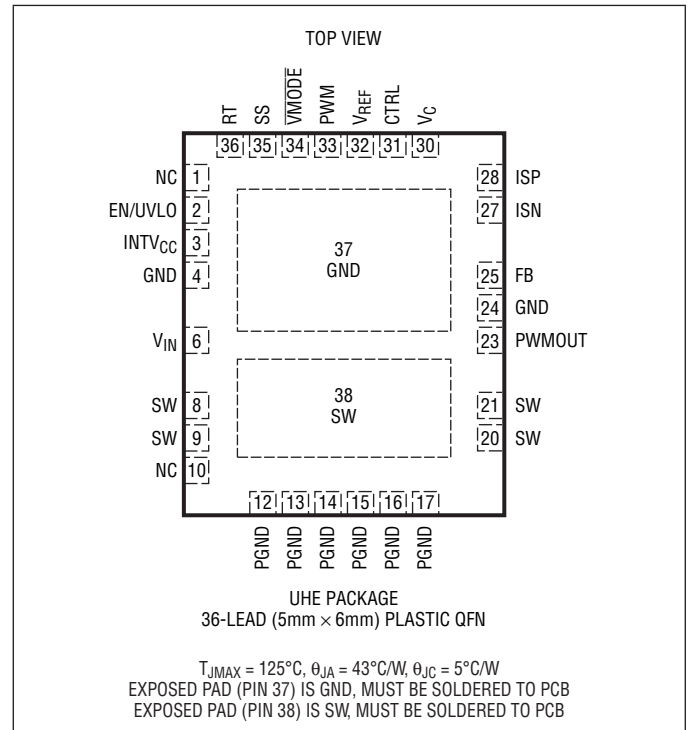

## ORDER INFORMATION

LEAD FREE FINISH	TAPE AND REEL	PART MARKING*	PACKAGE DESCRIPTION	TEMPERATURE RANGE
LT3956EUHE#PBF	LT3956EUHE#TRPBF	3956	36-Lead (5mm × 6mm) Plastic QFN	-40°C to 125°C
LT3956IUHE#PBF	LT3956IUHE#TRPBF	3956	36-Lead (5mm × 6mm) Plastic QFN	-40°C to 125°C

Consult LTC Marketing for parts specified with wider operating temperature ranges. \*The temperature grade is identified by a label on the shipping container.

For more information on lead free part marking, go to: <http://www.linear.com/leadfree/>

This product is only offered in trays. For more information go to: <http://www.linear.com/packaging/>

## ELECTRICAL CHARACTERISTICS

The ● denotes the specifications which apply over the full operating temperature range, otherwise specifications are at  $T_A = 25^\circ\text{C}$ .  $V_{IN} = 24\text{V}$ , EN/UVLO = 24V, CTRL = 2V, PWM = 5V, unless otherwise noted.

PARAMETER	CONDITIONS	MIN	TYP	MAX	UNITS	
$V_{IN}$ Minimum Operating Voltage	$V_{IN}$ Tied to INTV <sub>CC</sub>	●		4.5	V	
$V_{IN}$ Shutdown $I_Q$	EN/UVLO = 0V EN/UVLO = 1.15V		0.1	1 5	$\mu\text{A}$ $\mu\text{A}$	
$V_{IN}$ Operating $I_Q$ (Not Switching)	PWM = 0V		1.4	1.7	mA	
$V_{REF}$ Voltage	$-100\mu\text{A} \leq I_{VREF} \leq 0\mu\text{A}$	●	1.965	2.00	2.045	V
$V_{REF}$ Line Regulation	$4.5\text{V} \leq V_{IN} \leq 80\text{V}$		0.006		%/V	

**ELECTRICAL CHARACTERISTICS** The ● denotes the specifications which apply over the full operating temperature range, otherwise specifications are at  $T_A = 25^\circ\text{C}$ .  $V_{IN} = 24\text{V}$ ,  $EN/UVLO = 24\text{V}$ ,  $CTRL = 2\text{V}$ ,  $PWM = 5\text{V}$ , unless otherwise noted.

PARAMETER	CONDITIONS		MIN	TYP	MAX	UNITS
SW Pin Leakage	SW = 48V			5	10	$\mu\text{A}$
SW Pin Current Limit		●	3.3	3.9	4.6	A
SW Pin Voltage Drop	I(SW) = 2A			220		mV
SS Pull-Up Current	Current Out of Pin		8	10	13	$\mu\text{A}$
<b>Error Amplifier</b>						
Full-Scale Current Sense Threshold ( $V_{(ISP-ISN)}$ )	FB = 0V, ISP = 48V, CTRL $\geq 1.2\text{V}$	●	240	250	257	mV
Current Sense Threshold at CTRL = 1V ( $V_{(ISP-ISN)}$ )	CTRL = 1V, FB = 0V, ISP = 48V	●	217	225	231	mV
Current Sense Threshold at CTRL = 0.5V ( $V_{(ISP-ISN)}$ )	CTRL = 0.5V	●	96	100	103	mV
Current Sense Threshold at CTRL = 0.1V ( $V_{(ISP-ISN)}$ )	CTRL = 0.1V, FB = 0V, ISP = 48V	●	-2.5	0	4.5	mV
CTRL Range for Current Sense Threshold Adjustment			0		1.1	V
CTRL Input Bias Current	Current Out of Pin, CTRL = 0V			50	100	nA
Current Sense Amplifier Input Common Mode Range ( $V_{ISN}$ )			2.9		80	V
ISP/ISN Short-Circuit Threshold ( $V_{(ISP-ISN)}$ )	ISN = 0V		300	335	370	mV
ISP/ISN Short-Circuit Fault Sensing Common Mode Range ( $V_{ISN}$ )			0		3	V
ISP/ISN Input Bias Current (Combined)	PWM = 5V (Active), ISP = ISN = 48V PWM = 0V (Standby), ISP = ISN = 48V			80 0	0.1	$\mu\text{A}$ $\mu\text{A}$
LED Current Sense Amplifier $g_m$				120		$\mu\text{S}$
$V_C$ Output Impedance	$1\text{V} < V_C < 2\text{V}$			15000		$\text{k}\Omega$
$V_C$ Standby Input Bias Current	PWM = 0V		-20		20	nA
FB Regulation Voltage ( $V_{FB}$ )	ISP = ISN = 0V, 48V	●	1.220 1.232	1.250 1.250	1.270 1.265	V V
FB Amplifier $g_m$	FB = $V_{FB}$ , ISP = ISN			480		$\mu\text{S}$
FB Pin Input Bias Current	Current Out of Pin, FB = 1V			40	100	nA
FB Voltage Loop Active Threshold	VMODE Falling		$V_{FB} - 65\text{mV}$	$V_{FB} - 50\text{mV}$	$V_{FB} - 40\text{mV}$	V
FB Overvoltage Threshold	PWMOUT Falling		$V_{FB} + 50\text{mV}$	$V_{FB} + 60\text{mV}$	$V_{FB} + 80\text{mV}$	V
<b>Oscillator</b>						
Switching Frequency	$R_T = 100\text{k}$ $R_T = 10\text{k}$	●	90 925	100 1000	125 1050	kHz kHz
SW Minimum Off-Time				170		ns
SW Minimum On-Time				200		ns
<b>Linear Regulator</b>						
INTV <sub>CC</sub> Regulation Voltage			7	7.15	7.3	V
Dropout ( $V_{IN} - \text{INTV}_{CC}$ )	$I_{\text{INTV}_{CC}} = -10\text{mA}$ , $V_{IN} = 7\text{V}$			1		V
INTV <sub>CC</sub> Undervoltage Lockout		●		4.1	4.4	V
INTV <sub>CC</sub> Current Limit			14	17	25	mA
INTV <sub>CC</sub> Current in Shutdown	EN/UVLO = 0V, INTV <sub>CC</sub> = 7V			8	12	$\mu\text{A}$

## ELECTRICAL CHARACTERISTICS

The ● denotes the specifications which apply over the full operating temperature range, otherwise specifications are at  $T_A = 25^\circ\text{C}$ .  $V_{IN} = 24\text{V}$ ,  $\text{EN/UVLO} = 24\text{V}$ ,  $\text{CTRL} = 2\text{V}$ ,  $\text{PWM} = 5\text{V}$ , unless otherwise noted.

PARAMETER	CONDITIONS		MIN	TYP	MAX	UNITS
<b>Logic Inputs/Outputs</b>						
PWM Threshold Voltage		●	0.85	1.35	1.8	V
PWM Pin Resistance to GND			45	60		$\text{k}\Omega$
EN/UVLO Threshold Voltage Falling		●	1.185	1.220	1.245	V
EN/UVLO Rising Hysteresis				20		mV
EN/UVLO Input Low Voltage	$I_{VIN}$ Drops Below $1\mu\text{A}$				0.4	V
EN/UVLO Pin Bias Current Low	$\text{EN/UVLO} = 1.15\text{V}$		1.7	2.1	2.5	$\mu\text{A}$
EN/UVLO Pin Bias Current High	$\text{EN/UVLO} = 1.30\text{V}$			10	100	nA
$\overline{\text{VMODE}}$ Output Low ( $V_{OL}$ )	$I_{\overline{\text{VMODE}}} = 1\text{mA}$				200	mV
$\overline{\text{VMODE}}$ Pin Leakage	$\text{FB} = 0\text{V}$ , $\overline{\text{VMODE}} = 12\text{V}$			0.1	5	$\mu\text{A}$
<b>PWMOUT Driver</b>						
$t_r$ PWMOUT Driver Output Rise Time	$C_L = 560\text{pF}$			35		ns
$t_f$ PWMOUT Driver Output Fall Time	$C_L = 560\text{pF}$			35		ns
PWMOUT Output Low ( $V_{OL}$ )					0.05	V
PWMOUT Output High ( $V_{OH}$ )			$\text{INTV}_{\text{CC}} - 0.05$			V

**Note 1:** Stresses beyond those listed under Absolute Maximum Ratings may cause permanent damage to the device. Exposure to any Absolute Maximum Rating condition for extended periods may affect device reliability and lifetime.

**Note 2:** The LT3956E is guaranteed to meet performance specifications from  $0^\circ\text{C}$  to  $125^\circ\text{C}$  junction temperature. Specifications over the  $-40^\circ\text{C}$

to  $125^\circ\text{C}$  operating junction temperature range are assured by design, characterization and correlation with statistical process controls. The LT3956I is guaranteed to meet performance specifications over the  $-40^\circ\text{C}$  to  $125^\circ\text{C}$  operating junction temperature range.

**Note 3:** For  $V_{IN}$  below  $6\text{V}$ , the EN/UVLO pin must not exceed  $V_{IN}$  for proper operation.

## TYPICAL PERFORMANCE CHARACTERISTICS

$T_A = 25^\circ\text{C}$ , unless otherwise noted.

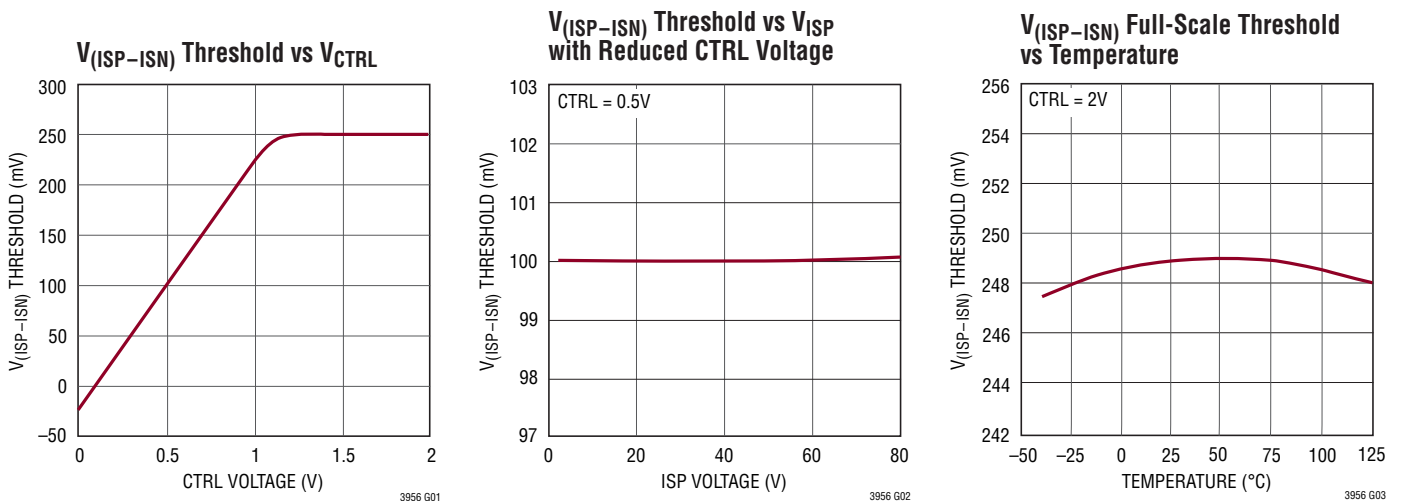

**TYPICAL PERFORMANCE CHARACTERISTICS**  $T_A = 25^\circ\text{C}$ , unless otherwise noted.

**FB Regulation Voltage ( $V_{FB}$ ) vs Temperature**

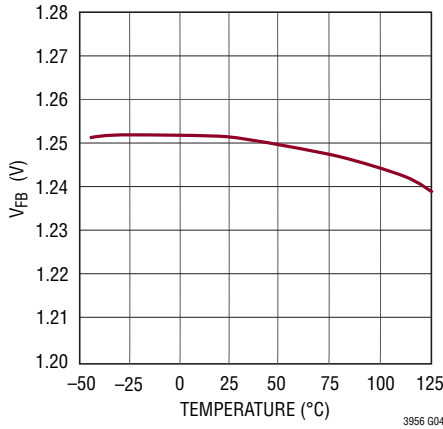

**$V_{REF}$  Voltage vs Temperature**

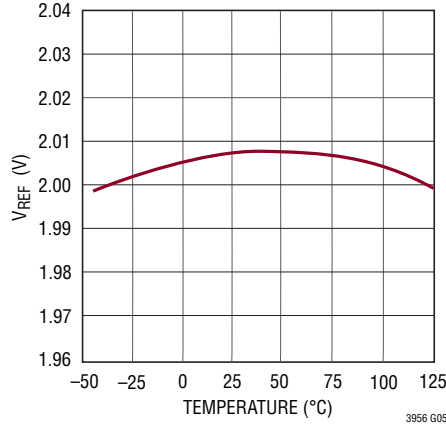

**$V_{REF}$  Voltage vs  $V_{IN}$**

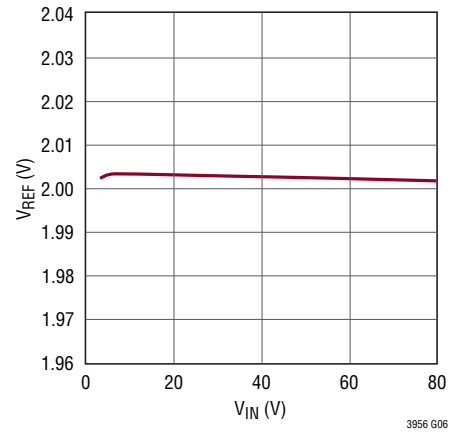

**Switching Frequency vs  $R_T$**

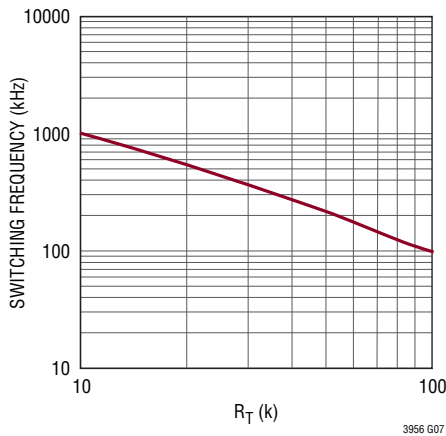

**Switching Frequency vs Temperature**

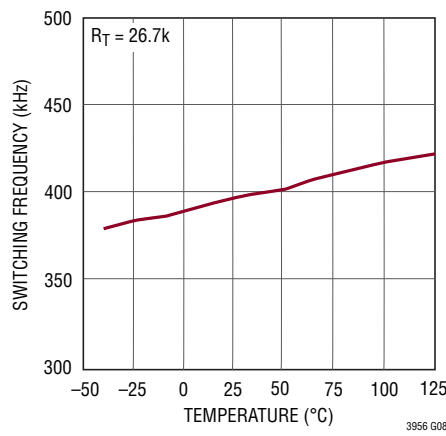

**EN/UVLO Hysteresis Current vs Temperature**

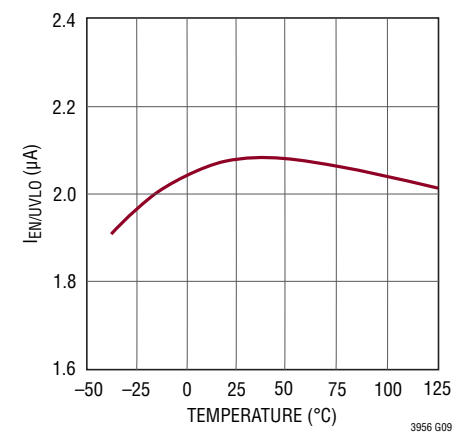

**Quiescent Current vs  $V_{IN}$**

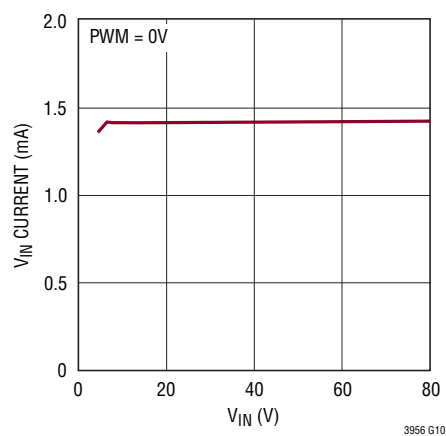

**SW Pin Current Limit vs Temperature**

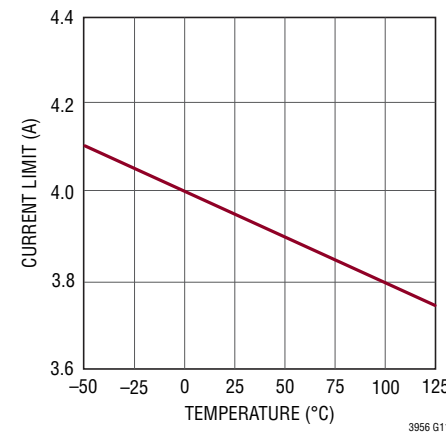

**EN/UVLO Threshold vs Temperature**

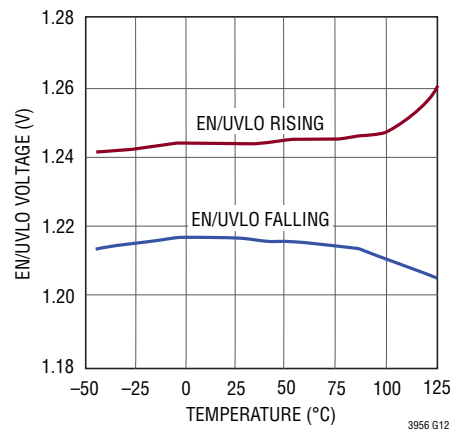

**TYPICAL PERFORMANCE CHARACTERISTICS**  $T_A = 25^\circ\text{C}$ , unless otherwise noted.

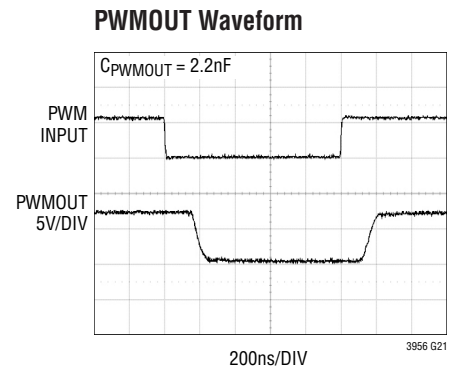
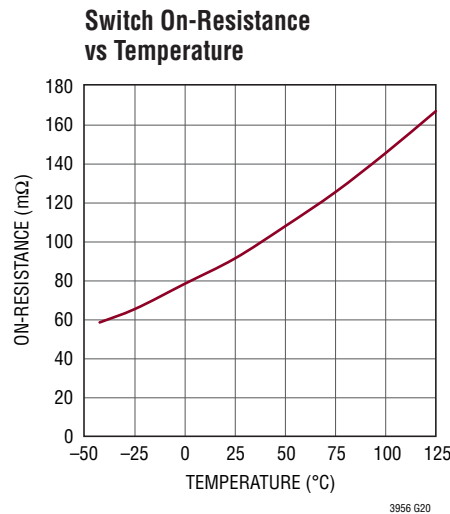
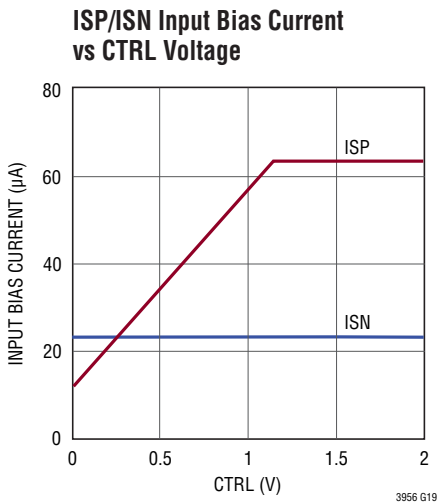
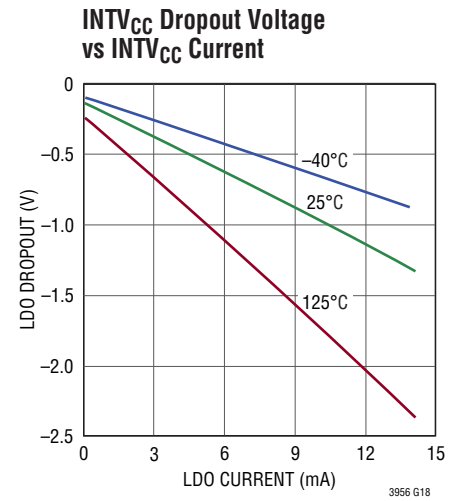
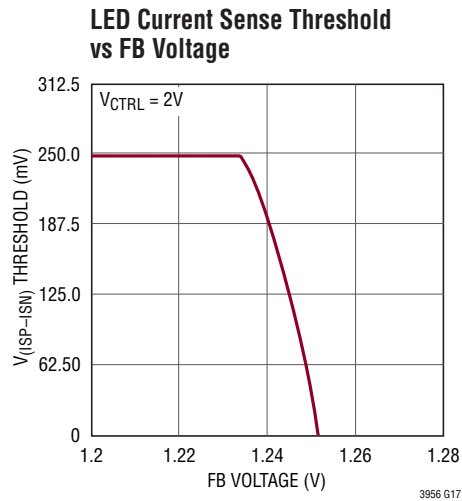
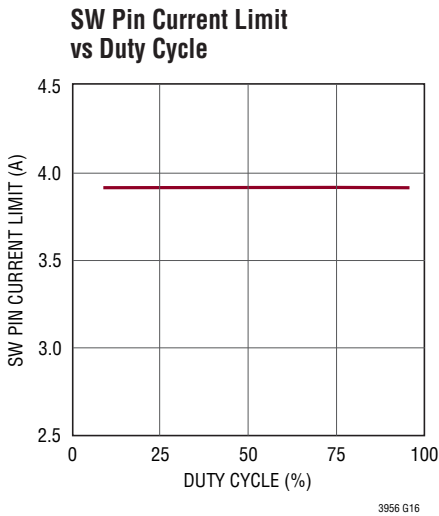
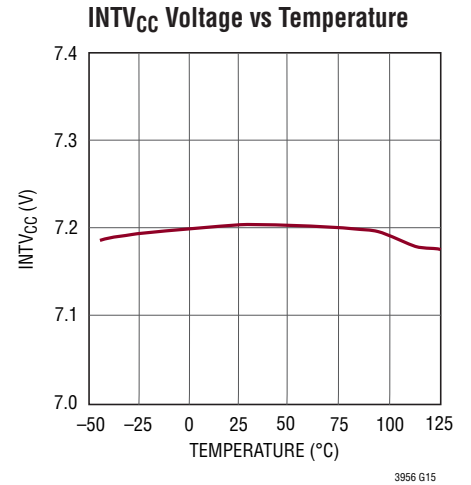
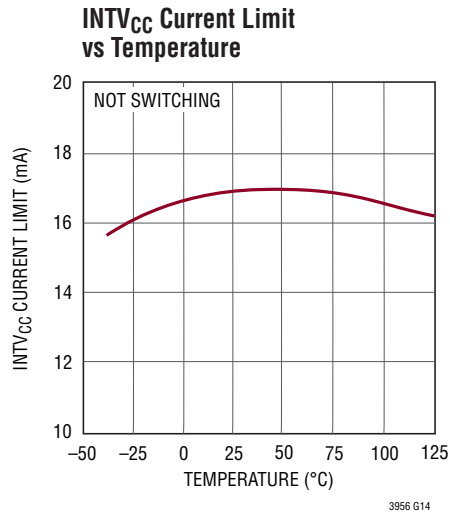
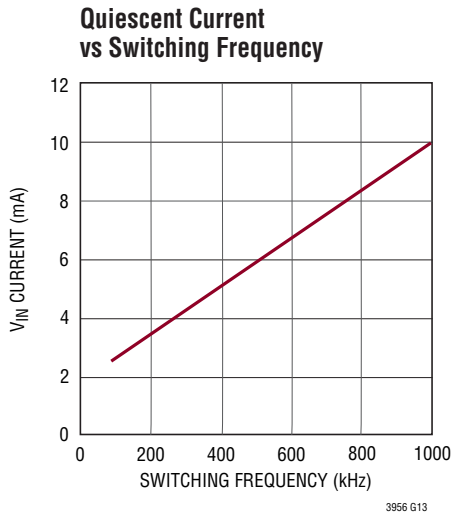

## PIN FUNCTIONS

**NC:** No Internal Connection. These pins may be left floating or connected to an adjacent pin.

**EN/UVLO:** Shutdown and Undervoltage Detect Pin. An accurate 1.22V falling threshold with externally programmable hysteresis detects when power is OK to enable switching. Rising hysteresis is generated by the external resistor divider and an accurate internal 2.1 $\mu$ A pull-down current. Above the 1.24V (nominal) threshold (but below 6V), EN/UVLO input bias current is sub- $\mu$ A. Below the falling threshold, a 2.1 $\mu$ A pull-down current is enabled so the user can define the hysteresis with the external resistor selection. An undervoltage condition resets soft-start. Tie to 0.4V, or less, to disable the device and reduce  $V_{IN}$  quiescent current below 1 $\mu$ A.

**INTV<sub>CC</sub>:** Regulated supply for internal loads, GATE driver and PWMOUT driver. Supplied from  $V_{IN}$  and regulates to 7.15V (typical). INTV<sub>CC</sub> must be bypassed with a 4.7 $\mu$ F capacitor placed close to the pin. Connect INTV<sub>CC</sub> directly to  $V_{IN}$  if  $V_{IN}$  is always less than or equal to 7V.

**GND:** Ground. The exposed pad, Pin 37, is ground and must be soldered directly to the ground plane.

**V<sub>IN</sub>:** Input Supply Pin. Must be locally bypassed with a 0.22 $\mu$ F (or larger) capacitor to PGND placed close to the IC.

**SW:** The exposed pad, Pin 38, is the drain of the switching N-channel MOSFET and must be connected to the external inductor.

**PGND:** Source terminal of switch and the GND input to the switch current comparator. Kelvin connect to the GND plane close to the IC using Pin 12. Pins 13 to 17 should be connected externally to the PGND terminals of components in the switching path. See the Board Layout section.

**PWMOUT:** Buffered Version of the PWM Signal. This pin is used to drive the LED load disconnect N-channel MOSFET or level shift. This pin also serves in a protection function for the FB overvoltage condition—will toggle if the FB input is greater than the FB regulation voltage ( $V_{FB}$ ) plus 60mV (typical). The PWMOUT pin is driven from INTV<sub>CC</sub>. Use of a MOSFET with gate cut-off voltage higher than 1V is recommended.

**FB:** Voltage Loop Feedback Pin. FB is intended for constant-voltage regulation or for LED protection/open LED detection. The internal transconductance amplifier with output  $V_C$  will regulate FB to 1.25V (nominal) through the DC/DC converter. If the FB input is regulating the loop, the  $\overline{VMODE}$  pull-down is asserted. This action may signal an open LED fault. If FB is driven above the FB threshold (by an external power supply spike, for example), the  $\overline{VMODE}$  pull-down will be de-asserted and the PWMOUT pin will be driven low to protect the LEDs from an overcurrent event. Do not leave the FB pin open. If not used, connect to GND.

**ISN:** Connection point for the negative terminal of the current feedback resistor. If ISN is greater than 2.9V, the LED current can be programmed by  $I_{LED} = 250\text{mV}/R_{LED}$  when  $V_{CTRL} > 1.2\text{V}$  or  $I_{LED} = (V_{CTRL} - 100\text{mV})/(4 \cdot R_{LED})$  if  $V_{CTRL} < 1\text{V}$ . Input bias current is typically 20 $\mu$ A. Below 3V, ISN is an input to the short-circuit protection feature that forces GATE to 0V if ISP exceeds ISN by more than 350mV (typ).

**ISP:** Connection point for the positive terminal of the current feedback resistor. Input bias current for this pin depends on CTRL pin voltage, as shown in the Typical Performance Characteristics. ISP is an input to the short-circuit protection feature when ISN is less than 3V.

**V<sub>C</sub>:** Transconductance Error Amplifier Output Pin. This pin is used to stabilize the voltage loop with an RC network. This pin is high impedance when PWM is low, a feature that stores the demand current state variable for the next PWM high transition. Connect a capacitor between this pin and GND; a resistor in series with the capacitor is recommended for fast transient response.

**CTRL:** Current Sense Threshold Adjustment Pin. Regulating threshold  $V_{(ISP - ISN)}$  is  $0.25 \cdot V_{CTRL}$  plus an offset for  $0\text{V} < V_{CTRL} < 1\text{V}$ . For  $V_{CTRL} > 1.2\text{V}$  the current sense threshold is constant at the full-scale value of 250mV. For  $1\text{V} < V_{CTRL} < 1.2\text{V}$ , the dependence of the current sense threshold upon  $V_{CTRL}$  transitions from a linear function to a constant value, reaching 98% of full-scale value by  $V_{CTRL} = 1.1\text{V}$ . Connect CTRL to  $V_{REF}$  for the 250mV default threshold. Do not leave this pin open.

## PIN FUNCTIONS

**V<sub>REF</sub>**: Voltage Reference Output Pin (typically 2V). This pin drives a resistor divider for the CTRL pin, either for analog dimming or for temperature limit/compensation of LED load. Can supply up to 100 $\mu$ A.

**PWM**: A signal low turns off switcher, idles oscillator and disconnects V<sub>C</sub> pin from all internal loads. PWMOUT pin follows PWM pin. PWM has an internal pull-down resistor. If not used, connect to INTV<sub>CC</sub>.

**V<sub>MODE</sub>**: An open-collector pull-down on  $\overline{\text{VMODE}}$  asserts if the FB input is greater than the FB regulation threshold minus 50mV (typical). To function, the pin requires an external pull-up resistor. When the PWM input is low and the DC/DC converter is idle, the  $\overline{\text{VMODE}}$  condition is latched to the last valid state when the PWM input was

high. When PWM input goes high again, the  $\overline{\text{VMODE}}$  pin will be updated. This pin may be used to report an open LED fault. Use a pull-up current less than 1mA.

**SS**: Soft-Start Pin. This pin modulates oscillator frequency and compensation pin voltage (V<sub>C</sub>) clamp. The soft-start interval is set with an external capacitor. The pin has a 10 $\mu$ A (typical) pull-up current source to an internal 2.5V rail. The soft-start pin is reset to GND by an undervoltage condition (detected by EN/UVLO pin) or thermal limit.

**RT**: Switching Frequency Adjustment Pin. Set the frequency using a resistor to GND (for resistor values, see the Typical Performance curve or Table 1). Do not leave the RT pin open.

## BLOCK DIAGRAM

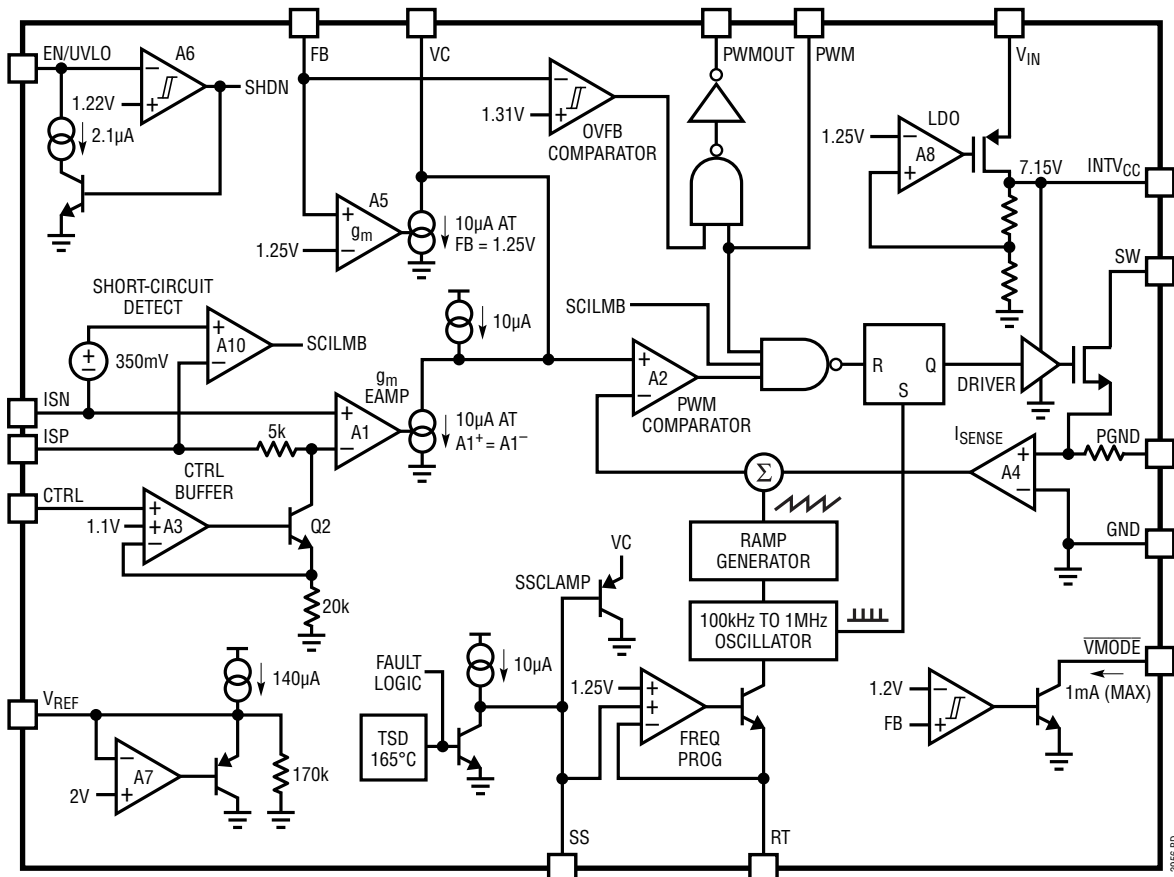

## OPERATION

The LT3956 is a constant-frequency, current mode converter with a low side N-channel MOSFET switch. The switch and PWMOUT pin drivers, and other chip loads, are powered from  $INTV_{CC}$ , which is an internally regulated supply. In the discussion that follows, it will be helpful to refer to the Block Diagram of the IC. In normal operation, with the PWM pin low, the power switch is turned off and the PWMOUT pin is driven to GND, the  $V_C$  pin is high impedance to store the previous switching state on the external compensation capacitor, and the ISP and ISN pin bias currents are reduced to leakage levels. When the PWM pin transitions high, the PWMOUT pin transitions high after a short delay. At the same time, the internal oscillator wakes up and generates a pulse to set the PWM latch, turning on the internal power MOSFET switch. A voltage input proportional to the switch current, sensed by an internal current sense resistor, is added to a stabilizing slope compensation ramp and the resulting switch-current sense signal is fed into the positive terminal of the PWM comparator. The current in the external inductor increases steadily during the time the switch is on. When the switch-current sense voltage exceeds the output of the error amplifier, labeled  $V_C$ , the latch is reset and the switch is turned off. During the switch off phase, the inductor current decreases. At the completion of each oscillator cycle, internal signals such as slope compensation return to their starting points and a new cycle begins with the set pulse from the oscillator.

Through this repetitive action, the PWM control algorithm establishes a switch duty cycle to regulate a current or voltage in the load. The  $V_C$  signal is integrated over many switching cycles and is an amplified version of the difference between the LED current sense voltage, measured between ISP and ISN, and the target difference voltage set by the CTRL pin. In this manner, the error amplifier sets the correct peak switch-current level to keep the LED current in regulation. If the error amplifier output increases, more current is demanded in the switch; if it decreases, less current is demanded. The switch current is monitored during the on-phase and is not allowed to exceed the current limit threshold of 3.9A (typical). If the SW pin exceeds the current limit threshold, the SR latch is reset regardless of the output state of the PWM compara-

tor. Likewise, at an ISP/ISN common mode voltage less than 3V, the difference between ISP and ISN is monitored to determine if the output is in a short-circuit condition. If the difference between ISP and ISN is greater than 335mV (typical), the SR latch will be reset regardless of the PWM comparator. These functions are intended to protect the power switch, as well as various external components in the power path of the DC/DC converter.

In voltage feedback mode, the operation is similar to that described above, except the voltage at the  $V_C$  pin is set by the amplified difference of the internal reference of 1.25V (nominal) and the FB pin. If FB is lower than the reference voltage, the switch current will increase; if FB is higher than the reference voltage, the switch demand current will decrease. The LED current sense feedback interacts with the FB voltage feedback so that FB will not exceed the internal reference and the voltage between ISP and ISN will not exceed the threshold set by the CTRL pin. For accurate current or voltage regulation, it is necessary to be sure that under normal operating conditions, the appropriate loop is dominant. To deactivate the voltage loop entirely, FB can be connected to GND. To deactivate the LED current loop entirely, the ISP and ISN should be tied together and the CTRL input tied to  $V_{REF}$ .

Two LED specific functions featured on the LT3956 are controlled by the voltage feedback pin. First, when the FB pin exceeds a voltage 50mV lower ( $-4\%$ ) than the FB regulation voltage, the pull-down driver on the  $\bar{V}MODE$  pin is activated. This function provides a status indicator that the load may be disconnected and the constant-voltage feedback loop is taking control of the switching regulator. When the FB pin exceeds the FB regulation voltage by 60mV (5% typical), the PWMOUT pin is driven low, ignoring the state of the PWM input. In the case where the PWMOUT pin drives a disconnect NFET, this action isolates the LED load from GND, preventing excessive current from damaging the LEDs. If the FB input exceeds the overvoltage threshold (1.31V typical), then an externally driven overvoltage event may have caused the FB pin to be too high and the  $\bar{V}MODE$  pull-down will be deactivated until the FB pin drops below the overvoltage threshold.

## APPLICATIONS INFORMATION

### INTV<sub>CC</sub> Regulator Bypassing and Operation

The INTV<sub>CC</sub> pin requires a capacitor for stable operation and to store the charge for the switch driver and PWMOUT pin switching currents. Choose a 10V rated low ESR, X7R or X5R ceramic capacitor for best performance. A 4.7μF capacitor will be adequate for many applications. Place the capacitor close to the IC to minimize the trace length to the INTV<sub>CC</sub> pin and also to the IC ground.

An internal current limit on the INTV<sub>CC</sub> output protects the LT3956 from excessive on-chip power dissipation. The INTV<sub>CC</sub> pin has its own undervoltage disable (UVLO) set to 4.1V (typical) to protect the internal MOSFET from excessive power dissipation caused by not being fully enhanced. If the INTV<sub>CC</sub> pin drops below the UVLO threshold, the PWMOUT pin will be forced to 0V, the power switch turned off and the soft-start pin will be reset.

If the input voltage, V<sub>IN</sub>, will not exceed 7V, then the INTV<sub>CC</sub> pin could be connected to the input supply. This action allows the LT3956 to operate from as low as 4.5V. Be aware that a small current (less than 12μA) will load the INTV<sub>CC</sub> in shutdown. Otherwise, the minimum operating V<sub>IN</sub> value is determined by the dropout voltage of the linear regulator and the 4.4V (4.1V typical) INTV<sub>CC</sub> undervoltage lockout threshold mentioned above.

### Programming the Turn-On and Turn-Off Thresholds With the EN/UVLO Pin

The falling UVLO value can be accurately set by the resistor divider. A small 2.1μA pull-down current is active when EN/UVLO is below the falling threshold. The purpose of this current is to allow the user to program the rising hysteresis. The following equations should be used to determine the values of the resistors:

$$V_{IN,FALLING} = 1.22 \cdot \frac{R1 + R2}{R2}$$

$$V_{IN,RISING} = 2.1\mu A \cdot R1 + V_{IN,FALLING}$$

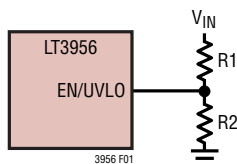

Figure 1

### LED Current Programming

The LED current is programmed by placing an appropriate value current sense resistor, R<sub>LED</sub>, between the ISP and ISN pins. Typically, sensing of the current should be done at the top of the LED string. If this option is not available, then the current may be sensed at the bottom of the string, but take caution that the minimum ISN value does not fall below 3V, which is the lower limit of the LED current regulation function. The CTRL pin should be tied to a voltage higher than 1.2V to get the full-scale 250mV (typical) threshold across the sense resistor. The CTRL pin can also be used to dim the LED current to zero, although relative accuracy decreases with the decreasing voltage sense threshold. When the CTRL pin voltage is less than 1V, the LED current is:

$$I_{LED} = \frac{V_{CTRL} - 100mV}{R_{LED} \cdot 4}$$

When the CTRL pin voltage is between 1V and 1.2V the LED current varies with CTRL, but departs from the previous equation by an increasing amount as the CTRL voltage increases. Ultimately, above CTRL = 1.2V, the LED current no longer varies with CTRL. At CTRL = 1.1V, the actual value of I<sub>LED</sub> is ~98% of the equation's estimate. When V<sub>CTRL</sub> is higher than 1.2V, the LED current is regulated to:

$$I_{LED} = \frac{250mV}{R_{LED}}$$

The CTRL pin should not be left open (tie to V<sub>REF</sub> if not used). The CTRL pin can also be used in conjunction with a thermistor to provide overtemperature protection for the LED load, or with a resistor divider to V<sub>IN</sub> to reduce output power and switching current when V<sub>IN</sub> is low. The presence of a time varying differential voltage signal (ripple) across ISP and ISN at the switching frequency is expected. The amplitude of this signal is increased by high LED load current, low switching frequency and/or a smaller value output filter capacitor. Some level of ripple signal is acceptable: the compensation capacitor on the V<sub>C</sub> pin filters the signal so the average difference between ISP and ISN is regulated to the user-programmed value. Ripple voltage amplitude (peak-to-peak) in excess of

## APPLICATIONS INFORMATION

20mV should not cause misoperation, but may lead to noticeable offset between the average value and the user-programmed value.

### Output Current Capability

An important consideration when using a switch with a fixed current limit is whether the regulator will be able to supply the load at the extremes of input and output voltage range. Several equations are provided to help determine this capability. Some margin to data sheet limits is included.

For boost converters:

$$I_{OUT(MAX)} \leq 2.5A \frac{V_{IN(MIN)}}{V_{OUT(MAX)}}$$

For buck mode converters:

$$I_{OUT(MAX)} \leq 2.5A$$

For SEPIC and buck-boost mode converters:

$$I_{OUT(MAX)} \leq 2.5A \frac{V_{IN(MIN)}}{(V_{OUT(MAX)} + V_{IN(MIN)})}$$

These equations assume the inductor value and switching frequency have been selected so that inductor ripple current is ~600mA. Ripple current higher than this value will reduce available output current. Be aware that current limited operation at high duty cycle can greatly increase inductor ripple current, so additional margin may be required at high duty cycle.

If some level of analog dimming is acceptable at minimum supply levels, then the CTRL pin can be used with a resistor divider to  $V_{IN}$  (as shown on page 1) to provide a higher output current at nominal  $V_{IN}$  levels.

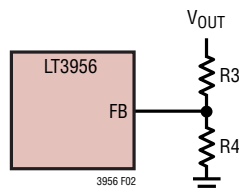

Figure 2. Feedback Resistor Connection for Boost or SEPIC LED Drivers

### Programming Output Voltage (Constant-Voltage Regulation) or Open LED/Overvoltage Threshold

For a boost or SEPIC application, the output voltage can be set by selecting the values of R3 and R4 (see Figure 2) according to the following equation:

$$V_{OUT} = 1.25 \cdot \frac{R3 + R4}{R4}$$

For a boost type LED driver, set the resistor from the output to the FB pin such that the expected voltage level during normal operation will not exceed 1.1V. For an LED driver of buck mode or a buck-boost mode configuration, the output voltage is typically level-shifted to a signal with respect to GND as illustrated in Figure 3. The output can be expressed as:

$$V_{OUT} = V_{BE} + 1.25 \cdot \frac{R3}{R4}$$

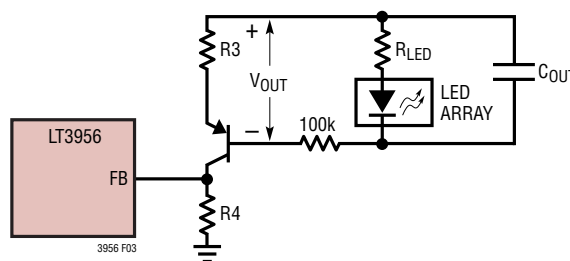

Figure 3. Feedback Resistor Connection for Buck Mode or Buck-Boost Mode LED Driver

### ISP/ISN Short-Circuit Protection Feature for SEPIC

The ISP and ISN pins have a protection feature independent of the LED current sense feature that operates at ISN below 3V. The purpose of this feature is to provide continuous current sensing when ISN is below the LED current sense common mode range (during start-up or an output short-circuit fault) to prevent the development of excessive switching currents that could damage the power components in a SEPIC converter. The action threshold (335mV, typ) is above the default LED current sense threshold, so that no interference will occur over the ISN voltage range where these two functions overlap. This feature acts in the same manner as switch-current limit — it prevents switch turn-on until the ISP/ISN difference falls below the threshold.

## APPLICATIONS INFORMATION

### Dimming Control

There are two methods to control the current source for dimming using the LT3956. One method uses the CTRL pin to adjust the current regulated in the LEDs. A second method uses the PWM pin to modulate the current source between zero and full current to achieve a precisely programmed average current. To make this method of current control more accurate, the switch demand current is stored on the  $V_C$  node during the quiescent phase when PWM is low. This feature minimizes recovery time when the PWM signal goes high. To further improve the recovery time, a disconnect switch may be used in the LED current path to prevent the ISP node from discharging during the PWM signal low phase. The minimum PWM on or off time will depend on the choice of operating frequency through the  $R_T$  input. For best overall performance, the minimum PWM low or high time should be at least six switching cycles ( $6\mu\text{s}$  for  $f_{\text{SW}} = 1\text{MHz}$ ).

### Programming the Switching Frequency

The  $R_T$  frequency adjust pin allows the user to program the switching frequency from 100kHz to 1MHz to optimize efficiency/performance or external component size. Higher frequency operation yields smaller component size but increases switching losses and gate driving current, and may not allow sufficiently high or low duty cycle operation. Lower frequency operation gives better performance at the cost of larger external component size. For an appropriate  $R_T$  resistor value see Table 1. An external resistor from the  $R_T$  pin to GND is required—do not leave this pin open.

**Table 1. Switching Frequency vs  $R_T$  Value**

$f_{\text{osc}}$ (kHz)	$R_T$ (k)
1000	10
900	11.8
800	13
700	15.4
600	17.8
500	21
400	26.7
300	35.7
200	53.6
100	100

### Duty Cycle Considerations

Switching duty cycle is a key variable defining converter operation, therefore, its limits must be considered when programming the switching frequency for a particular application. The fixed minimum on-time and minimum off-time (see Figure 4) and the switching frequency define the minimum and maximum duty cycle of the switch, respectively. The following equations express the minimum/maximum duty cycle:

$$\text{Min Duty Cycle} = (\text{minimum on-time}) \cdot \text{switching frequency}$$

$$\text{Max Duty Cycle} = 1 - (\text{minimum off-time}) \cdot \text{switching frequency}$$

When calculating the operating limits, the typical values for on/off-time in the data sheet should be increased by at least 60ns to allow margin for PWM control latitude and SW node rise/fall times.

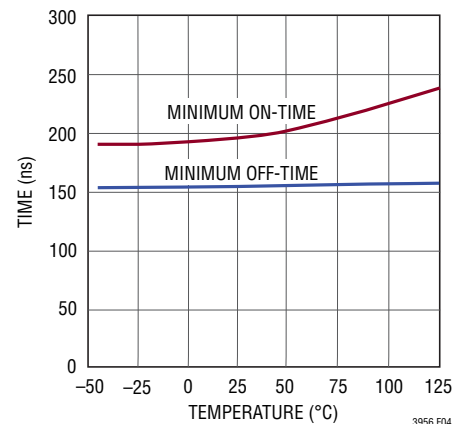

**Figure 4. Typical Switch Minimum On and Off Pulse Width vs Temperature**

### Thermal Considerations

The LT3956 is rated to a maximum input voltage of 80V. Careful attention must be paid to the internal power dissipation of the IC at higher input voltages to ensure that a junction temperature of 125°C is not exceeded. This junction limit is especially important when operating at high ambient temperatures. If the LT3956's junction temperature reaches 165°C (typ), the power switch will be turned off and the soft-start (SS) pin will be discharged to GND. Switching

3956f

## APPLICATIONS INFORMATION

will be enabled after the device temperature drops 10°C. This function is intended to protect the device during momentary overload conditions.

The major contributors to internal power dissipation are the current in the linear regulator to drive the switch, and the ohmic losses in the switch. The linear regulator power is proportional to  $V_{IN}$  and switching frequency, so at high  $V_{IN}$  the switching frequency should be chosen carefully to ensure that the IC does not exceed a safe junction temperature. The internal junction temperature of the IC can be estimated by:

$$T_J = T_A + [V_{IN} \cdot (I_Q + f_{SW} \cdot 7nC) + I_{SW}^2 \cdot 0.14\Omega \cdot D_{SW}] \cdot \theta_{JA}$$

where  $T_A$  is the ambient temperature,  $I_Q$  is the quiescent current of the part (maximum 1.7mA) and  $\theta_{JA}$  is the package thermal impedance (43°C/W for the 5mm × 6mm QFN package). For example, an application with  $T_{A(MAX)} = 85^\circ\text{C}$ ,  $V_{IN(MAX)} = 60\text{V}$ ,  $f_{SW} = 400\text{kHz}$ , and having an average switching current of 2.5A at 70% duty cycle, the maximum IC junction temperature will be approximately:

$$T_J = 85^\circ\text{C} + [(2.5\text{A})^2 \cdot 0.14\Omega \cdot 0.7 + 60\text{V} \cdot (1.7\text{mA} + 400\text{kHz} \cdot 7nC)] \cdot 43^\circ\text{C/W} = 123^\circ\text{C}$$

The Exposed Pads on the bottom of the package must be soldered to a plane. These should then be connected to internal copper planes with thermal vias placed directly under the package to spread out the heat dissipated by the IC.

### Open LED Detection

The LT3956 provides an open-drain status pin,  $\overline{VMODE}$ , that pulls low when the FB pin is within ~50mV of its 1.25V regulated voltage. If the open LED clamp voltage is programmed correctly using the FB pin, then the FB pin should never exceed 1.1V when LEDs are connected, therefore, the only way for the FB pin to be within 50mV of the regulation voltage is for an open LED event to have occurred.

### Input Capacitor Selection

The input capacitor supplies the transient input current for the power inductor of the converter and must be placed and sized according to the transient current requirements. The switching frequency, output current and tolerable input

voltage ripple are key inputs to estimating the capacitor value. An X7R type ceramic capacitor is usually the best choice since it has the least variation with temperature and DC bias. Typically, boost and SEPIC converters require a lower value capacitor than a buck mode converter. Assuming that a 100mV input voltage ripple is acceptable, the required capacitor value for a boost converter can be estimated as follows:

$$C_{IN(\mu F)} = I_{LED(A)} \cdot \frac{V_{OUT}}{V_{IN}} \cdot T_{SW(\mu s)} \cdot \frac{1\mu F}{A \cdot \mu s}$$

Therefore, a 4.7μF capacitor is an appropriate selection for a 400kHz boost regulator with 12V input, 48V output and 1A load.

With the same  $V_{IN}$  voltage ripple of 100mV, the input capacitor for a buck converter can be estimated as follows:

$$C_{IN(\mu F)} = I_{LED(A)} \cdot T_{SW(\mu s)} \cdot \frac{4.7\mu F}{A \cdot \mu s}$$

A 10μF input capacitor is an appropriate selection for a 400kHz buck mode converter with a 1A load.

In the buck mode configuration, the input capacitor has large pulsed currents due to the current returned through the Schottky diode when the switch is off. In this buck converter case it is important to place the capacitor as close as possible to the Schottky diode and to the PGND return of the switch. It is also important to consider the ripple current rating of the capacitor. For best reliability, this capacitor should have low ESR and ESL and have an adequate ripple current rating. The RMS input current for a buck mode LED driver is:

$$I_{IN(RMS)} = I_{LED} \cdot \sqrt{(1-D) \cdot D}$$

where D is the switch duty cycle.

**Table 2. Recommended Ceramic Capacitor Manufacturers**

MANUFACTURER	WEB SITE
TDK	www.tdk.com
Kemet	www.kemet.com
Murata	www.murata.com
Taiyo Yuden	www.t-yuden.com

## APPLICATIONS INFORMATION

### Output Capacitor Selection

The selection of the output capacitor depends on the load and converter configuration, i.e., step-up or step-down and the operating frequency. For LED applications, the equivalent resistance of the LED is typically low and the output filter capacitor should be sized to attenuate the current ripple. Use of an X7R type ceramic capacitor is recommended.

To achieve the same LED ripple current, the required filter capacitor is larger in the boost and buck-boost mode applications than that in the buck mode applications. Lower operating frequencies will require proportionately higher capacitor values.

### Soft-Start Capacitor Selection

For many applications, it is important to minimize the inrush current at start-up. The built-in soft-start circuit significantly reduces the start-up current spike and output voltage overshoot. The soft-start interval is set by the soft-start capacitor selection according to the equation:

$$T_{SS} = C_{SS} \cdot \frac{2V}{10\mu A}$$

A typical value for the soft-start capacitor is 0.01μF. The soft-start pin reduces the oscillator frequency and the maximum current in the switch. The soft-start capacitor is discharged when EN/UVLO falls below its threshold, during an overtemperature event or during an INTV<sub>CC</sub> undervoltage event. During start-up with EN/UVLO, charging of the soft-start capacitor is enabled after the first PWM high period.

### Schottky Rectifier Selection

The power Schottky diode conducts current during the interval when the switch is turned off. Select a diode rated for the maximum SW voltage of the application and the RMS diode current. If using the PWM feature for dimming,

it is important to consider diode leakage, which increases with the temperature, from the output during the PWM low interval. Therefore, choose the Schottky diode with sufficiently low leakage current. Table 3 has some recommended component vendors.

**Table 3. Schottky Rectifier Manufacturers**

VENDOR	WEB SITE
On Semiconductor	www.onsemi.com
Diodes, Inc.	www.diodes.com
Central Semiconductor	www.centralsemi.com

### Inductor Selection

The inductor used with the LT3956 should have a saturation current rating appropriate to the maximum switch current of 4.6A. Choose an inductor value based on operating frequency, input and output voltage to provide a current mode signal of approximately 0.6A magnitude. The following equations are useful to estimate the inductor value ( $T_{SW} = 1/f_{OSC}$ ):

$$L_{BUCK} = \frac{T_{SW} \cdot V_{LED} (V_{IN} - V_{LED})}{V_{IN} \cdot 0.6A}$$

$$L_{BUCK-BOOST} = \frac{T_{SW} \cdot V_{LED} \cdot V_{IN}}{(V_{LED} + V_{IN}) \cdot 0.6A}$$

$$L_{BOOST} = \frac{T_{SW} \cdot V_{IN} (V_{LED} - V_{IN})}{V_{LED} \cdot 0.6A}$$

Table 4 provides some recommended inductor vendors.

**Table 4. Inductor Manufacturers**

VENDOR	WEB SITE
Sumida	www.sumida.com
Würth Elektronik	www.we-online.com
Coiltronics	www.cooperet.com
Renco	www.rencousa.com
Coilcraft	www.coilcraft.com

## APPLICATIONS INFORMATION

### Loop Compensation

The LT3956 uses an internal transconductance error amplifier whose  $V_C$  output compensates the control loop. The external inductor, output capacitor and the compensation resistor and capacitor determine the loop stability.

The inductor and output capacitor are chosen based on performance, size and cost. The compensation resistor and capacitor at  $V_C$  are selected to optimize control loop response and stability. For typical LED applications, a 4.7nF compensation capacitor at  $V_C$  is adequate, and a series resistor should always be used to increase the slew rate on the  $V_C$  pin to maintain tighter regulation of LED current during fast transients on the input supply to the converter.

### Board Layout

The high speed operation of the LT3956 demands careful attention to board layout and component placement. The exposed pads of the package are important for thermal management of the IC. It is crucial to achieve a good electrical and thermal contact between the GND exposed pad and the ground plane of the board. To reduce electromagnetic

interference (EMI), it is important to minimize the area of the high  $dV/dt$  switching node between the inductor, SW pin and anode of the Schottky rectifier. Use a ground plane under the switching node to eliminate interplane coupling to sensitive signals. The lengths of the high  $dI/dt$  traces: 1) from the switch node through the switch to PGND, and 2) from the switch node through the Schottky rectifier and filter capacitor to PGND, should be minimized. The ground points of these two switching current traces should come to a common point then connect to the ground plane at the PGND pin of the LT3956 through a separate via to Pin 12, as shown in the suggested layout (Figure 5). Likewise, the ground terminal of the bypass capacitor for the  $INTV_{CC}$  regulator should be placed near the GND of the IC. The ground for the compensation network and other DC control signals should be star connected to the GND Exposed Pad of the IC. Do not extensively route high impedance signals such as FB and  $V_C$ , as they may pick up switching noise. Since there is a small variable DC input bias current to the ISN and ISP inputs, resistance in series with these pins should be minimized to avoid creating an offset in the current sense threshold.

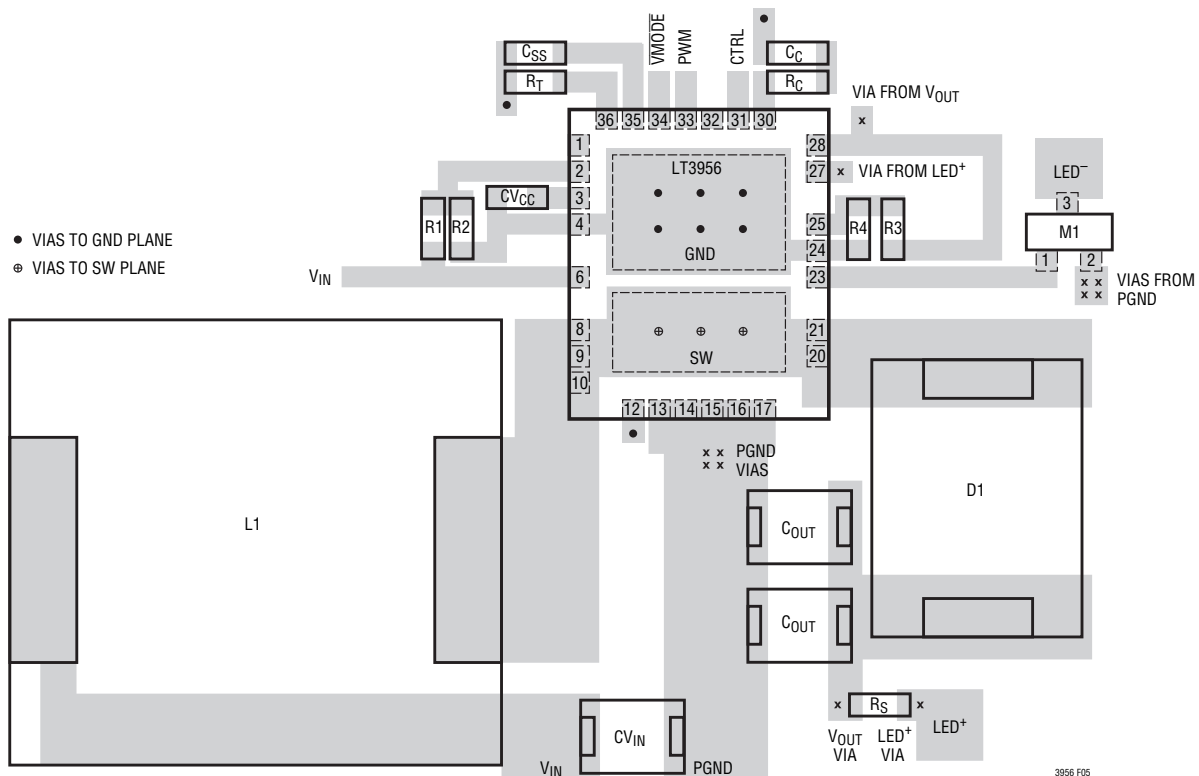
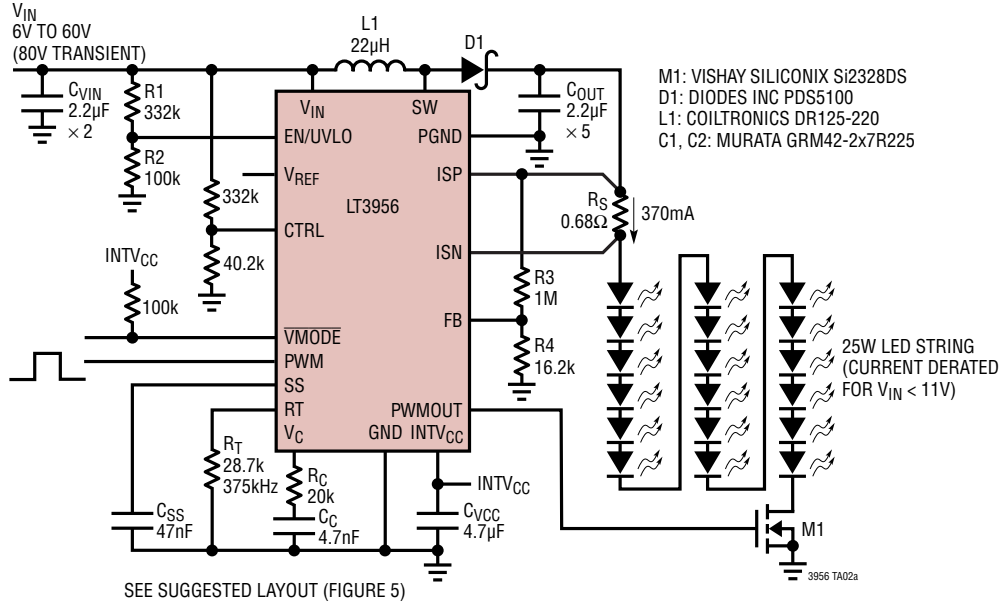

Figure 5. Boost Converter Suggested Layout

TYPICAL APPLICATIONS

94% Efficient 25W White LED Headlamp Driver



PWM Waveforms for 25W Headlamp Driver

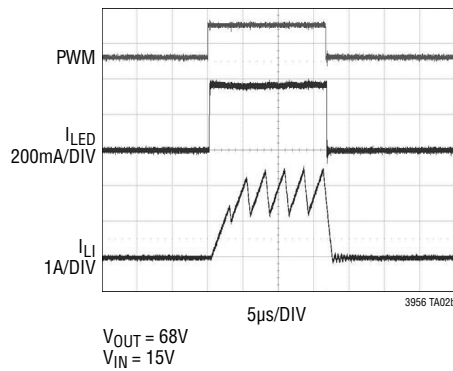

# TYPICAL APPLICATIONS

**Buck-Boost Mode LED Driver**

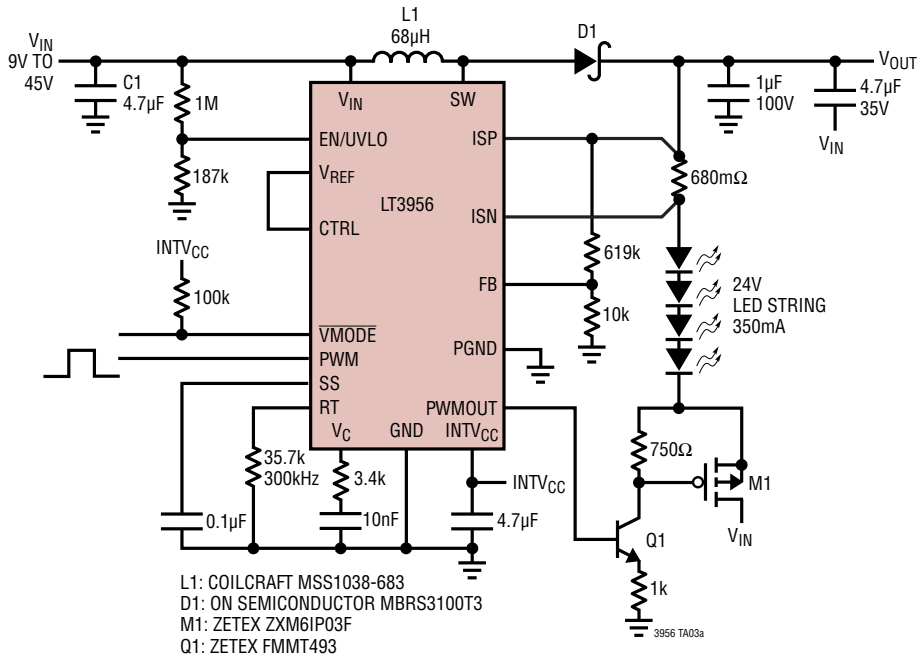

**Efficiency vs  $V_{IN}$**

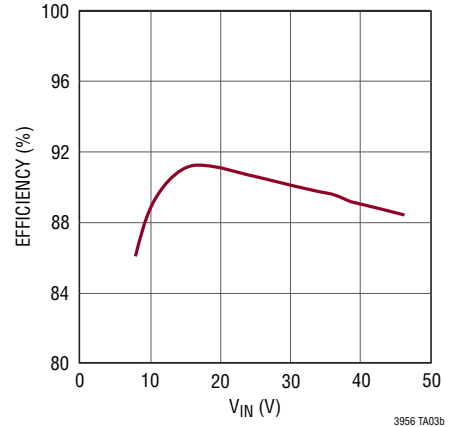

**28V<sub>IN</sub> /0V to 28V SEPIC SuperCap Charger with Input Current Limit**

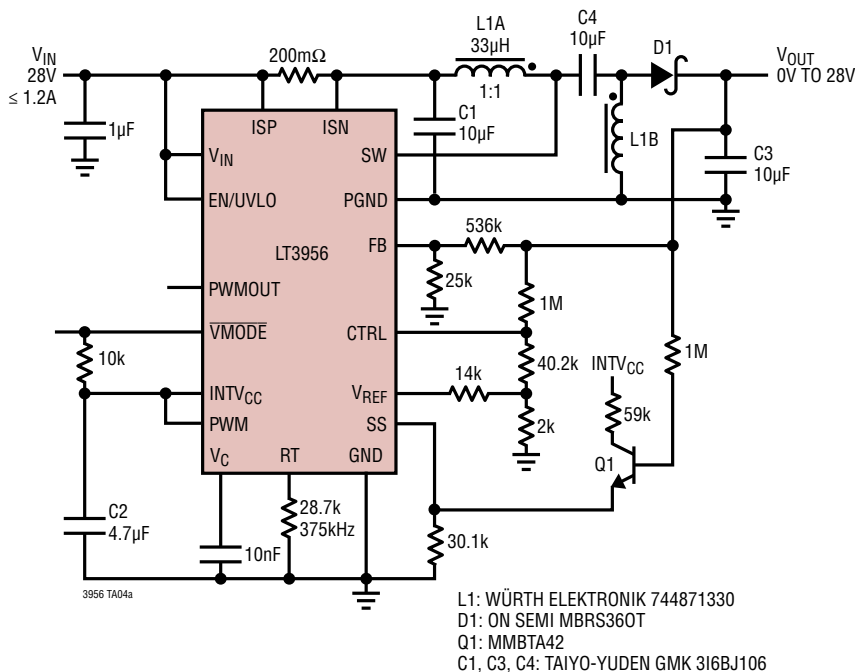

**Input and Output Current vs Output Voltage**

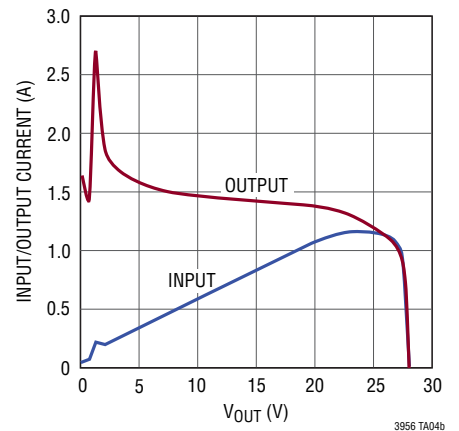

## TYPICAL APPLICATIONS

### 90% Efficient, 20W SEPIC LED Driver

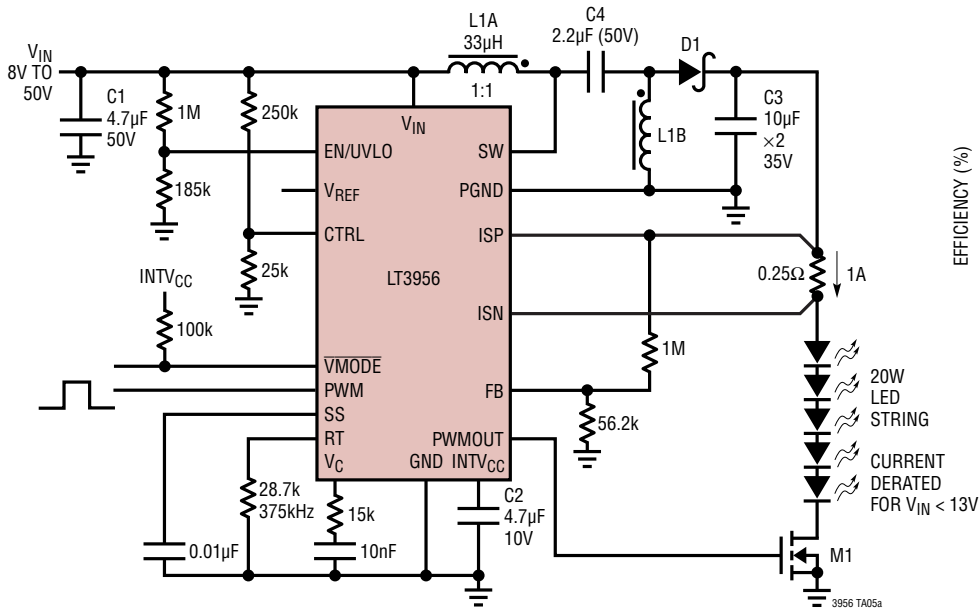

L1: COILTRONICS DRQ127-330  
 D1: VISHAY PDS5100  
 M1: ZETEX ZXM61N03F

### Efficiency vs V<sub>IN</sub>

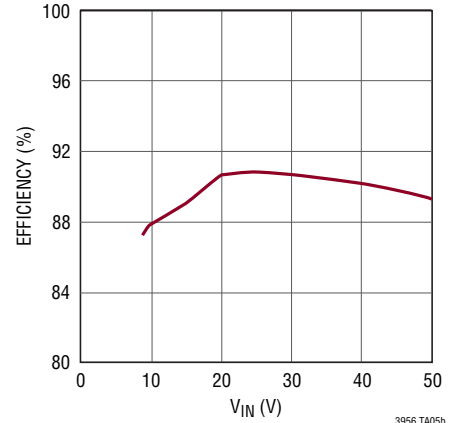

3956 TA05a

### 90W Buck Mode LED Driver, 80V<sub>IN</sub>/60V<sub>OUT</sub>

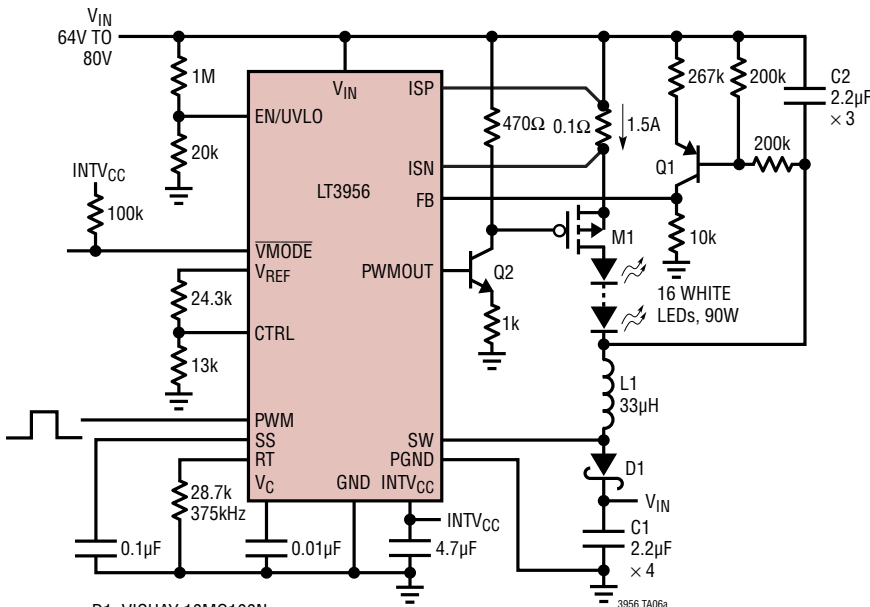

D1: VISHAY 10MQ100N  
 L1: WÜRTH ELEKTRONIK 744066330  
 M1: VISHAY SILICONIX SI7113DN  
 Q1: ZETEX FMMT593  
 Q2: ZETEX FMMT493  
 C1, C2: MURATA GRM42-2x7R225

### Efficiency vs V<sub>IN</sub>

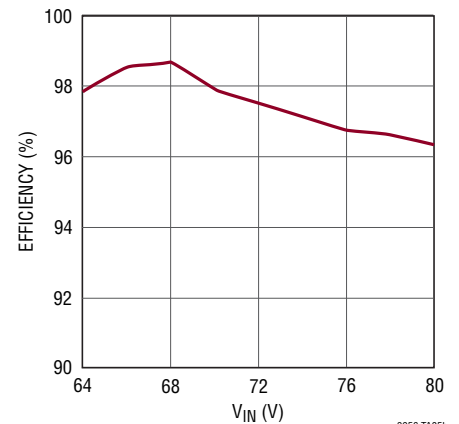

3956 TA06b

# PACKAGE DESCRIPTION

**UHE Package**  
**Variation: UHE28MA**  
**36-Lead Plastic QFN (5mm × 6mm)**  
 (Reference LTC DWG # 05-08-1836 Rev C)

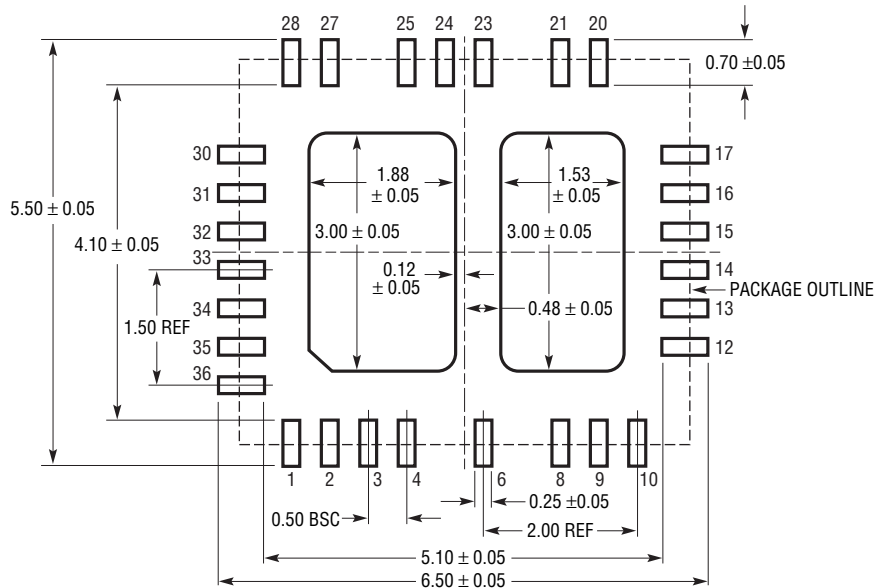

RECOMMENDED SOLDER PAD PITCH AND DIMENSIONS  
 APPLY SOLDER MASK TO AREAS THAT ARE NOT SOLDERED

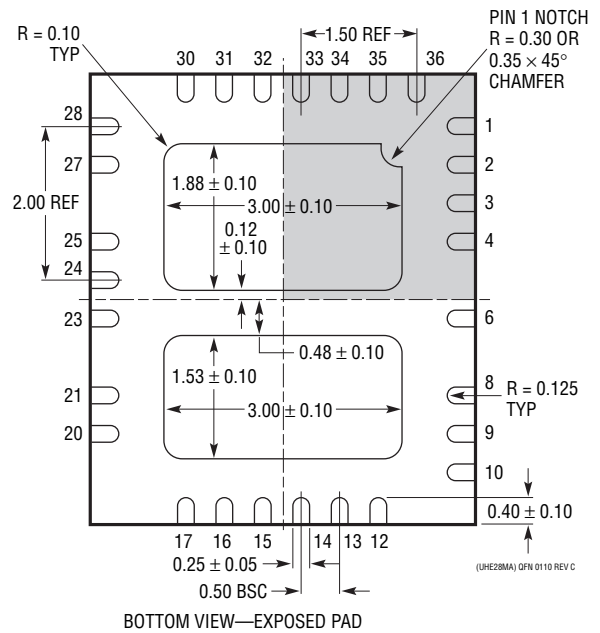
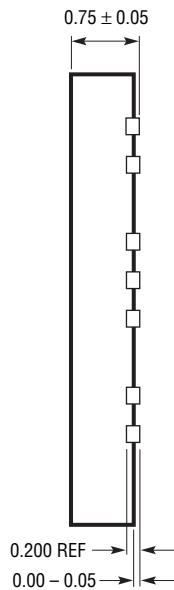
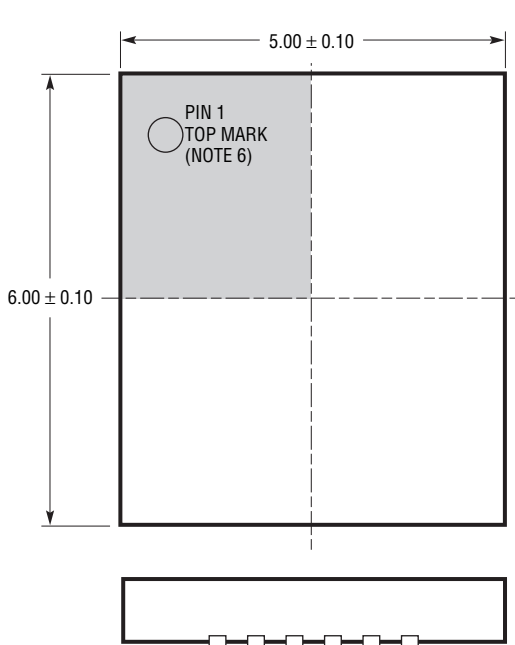

- NOTE:
1. DRAWING IS NOT A JEDEC PACKAGE OUTLINE
  2. DRAWING NOT TO SCALE
  3. ALL DIMENSIONS ARE IN MILLIMETERS
  4. DIMENSIONS OF EXPOSED PAD ON BOTTOM OF PACKAGE DO NOT INCLUDE MOLD FLASH. MOLD FLASH, IF PRESENT, SHALL NOT EXCEED 0.20mm ON ANY SIDE

5. EXPOSED PAD SHALL BE SOLDER PLATED
6. SHADED AREA IS ONLY A REFERENCE FOR PIN 1 LOCATION ON THE TOP AND BOTTOM OF PACKAGE

(UHE28MA) QFN 0110 REV C

## TYPICAL APPLICATION

### Buck Mode 1A LED Driver with High Dimming Ratio and Open LED Reporting

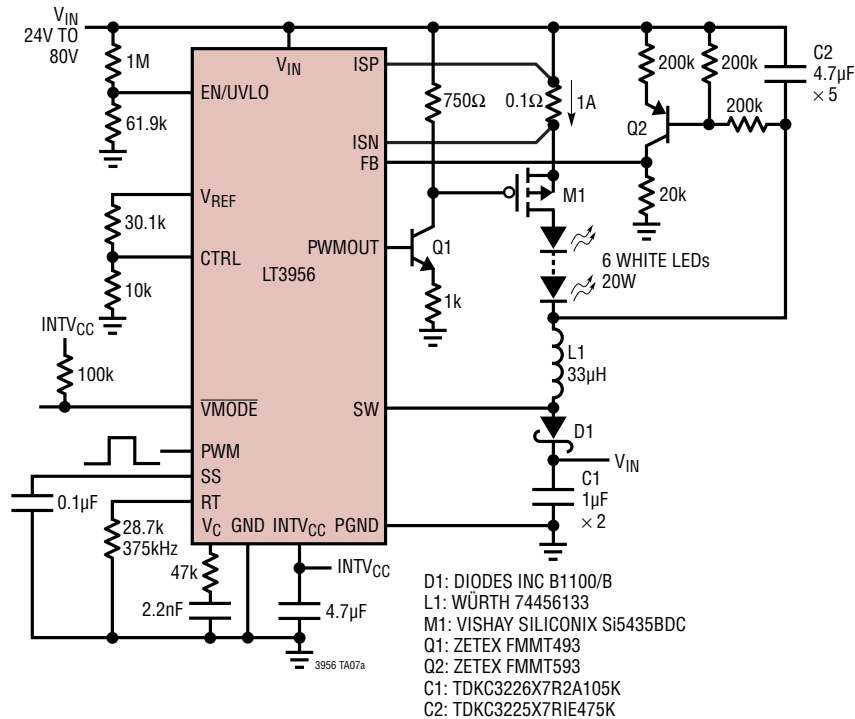

### Efficiency vs $V_{IN}$

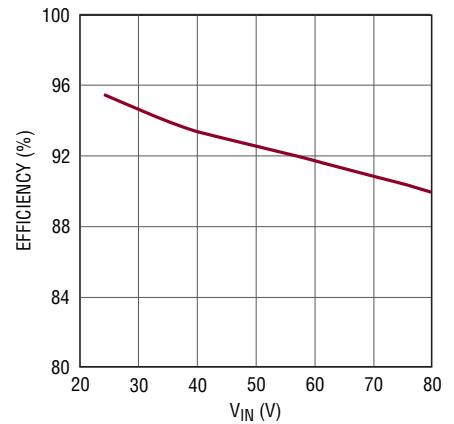

3956 TA06b

## RELATED PARTS

PART NUMBER	DESCRIPTION	COMMENTS
LT3756/LT3756-1/ LT3756-2	100V <sub>IN</sub> , 100V <sub>OUT</sub> , Full Featured LED Controller	$V_{IN}$ : 6V to 100V, $V_{OUT(MAX)}$ = 100V, True Color PWM Dimming = 3000:1, $I_{SD}$ < 1μA, 3mm × 3mm QFN-16 and MS16E Packages
LT3755/LT3755-1/ LT3755-2	40V <sub>IN</sub> , 75V <sub>OUT</sub> , Full Featured LED Controller	$V_{IN}$ : 4.5V to 40V, $V_{OUT(MAX)}$ = 60V, True Color PWM Dimming = 3000:1, $I_{SD}$ < 1μA, 3mm × 3mm QFN-16 and MS16E Packages
LT3474	36V, 1A ( $I_{LED}$ ), 2MHz, Step-Down LED Driver	$V_{IN}$ : 4V to 36V, $V_{OUT(MAX)}$ = 13.5V, True Color PWM Dimming = 400:1, $I_{SD}$ < 1μA, TSSOP16E Package
LT3475	Dual 1.5A ( $I_{LED}$ ), 36V, 2MHz Step-Down LED Driver	$V_{IN}$ : 4V to 36V, $V_{OUT(MAX)}$ = 13.5V, True Color PWM Dimming = 3000:1, $I_{SD}$ < 1μA, TSSOP20E Package
LT3476	Quad Output 1.5A, 36V, 2MHz High Current LED Driver with 1000:1 Dimming	$V_{IN}$ : 2.8V to 16V, $V_{OUT(MAX)}$ = 36V, True Color PWM Dimming = 1000:1, $I_{SD}$ < 10μA, 5mm × 7mm QFN Package
LT3477	3A, 42V, 3MHz Boost, Buck-Boost, Buck LED Driver	$V_{IN}$ : 2.5V to 25V, $V_{OUT(MAX)}$ = 40V, Dimming = Analog/PWM, $I_{SD}$ < 1μA, QFN and TSSOP20E Packages
LT3478/LT3478-1	4.5A, 42V, 2.5MHz High Current LED Driver with 3000:1 Dimming	$V_{IN}$ : 2.8V to 36V, $V_{OUT(MAX)}$ = 42V, True Color PWM Dimming = 3000:1, $I_{SD}$ < 3μA, TSSOP16E Package