

Dual Full Function White LED Driver with Integrated Schottky Diodes

FEATURES

- Drives Up to 12 White LEDs (6 in Series per Converter) from a 3V Supply
- Two Independent Boost Converters Capable of Driving Asymmetric LED Strings
- Independent Dimming and Shutdown Control of the Two LED Strings
- High Side Sense Allows “One Wire Current Source” per Converter
- Internal Schottky Diodes
- Open LED Protection (32V)
- 2.3MHz Switching Frequency
- $\pm 5\%$ Reference Accuracy
- V_{IN} Range: 2.5V to 10V
- Dual Wide 250:1 True Color PWM™ Dimming
- Requires Only $1\mu\text{F}$ Output Capacitor per Converter
- Available in a 3mm \times 2mm 10-Pin DFN Package

APPLICATIONS

- Cellular Phones
- PDAs, Handheld Computers
- Digital Cameras
- MP3 Players
- GPS Receivers

DESCRIPTION

The LT[®]3497 is a dual full function step-up DC/DC converter specifically designed to drive up to 12 white LEDs (6 white LEDs in series per converter) from a Li-Ion cell. Series connection of the LEDs provides identical LED currents resulting in uniform brightness and eliminating the need for ballast resistors and expensive factory calibration.

The two independent converters are capable of driving asymmetric LED strings. Accurate LED dimming and shutdown of the two LED strings can also be controlled independently. The LT3497 features a unique high side LED current sense that enables the part to function as a “one wire current source;” one side of the LED string can be returned to ground anywhere, allowing a simpler 1-wire LED connection. Traditional LED drivers use a grounded resistor to sense LED current, requiring a 2-wire connection to the LED string.

The 2.3MHz switching frequency allows the use of tiny inductors and capacitors. Few external components are needed for the dual white LED Driver: open-LED protection and the Schottky diodes are all contained inside the 3mm \times 2mm DFN package. With such a high level of integration, the LT3497 provides a high efficiency dual white LED driver solution in the smallest of spaces.

LT, LT, LTC and LTM are registered trademarks of Linear Technology Corporation. True Color PWM is a trademark of Linear Technology Corporation. All other trademarks are the property of their respective owners.

TYPICAL APPLICATION

Li-Ion Power Driver for 4/4 White LEDs

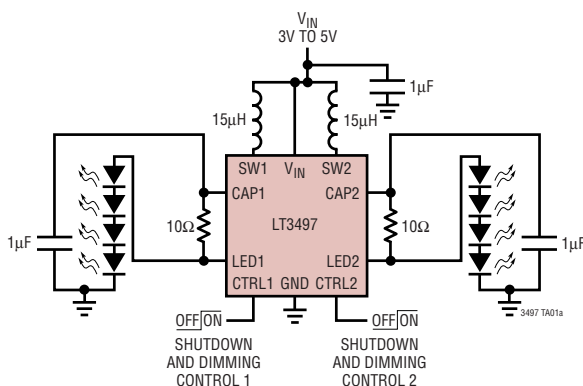

Efficiency

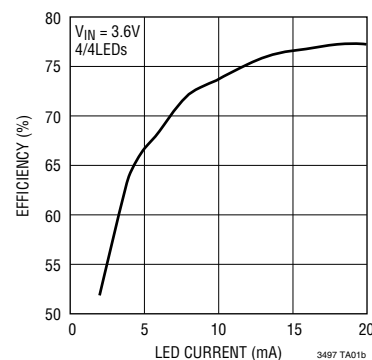

ABSOLUTE MAXIMUM RATINGS

(Note 1)

Input Voltage (VIN)	10V
SW1, SW2 Voltages	35V
CAP1, CAP2 Voltages	35V
CTRL1, CTRL2 Voltages	10V
LED1, LED2 Voltages	35V
Operating Temperature Range	-40°C to 85°C
Maximum Junction Temperature	125°C
Storage Temperature Range	-65°C to 125°C

PACKAGE/ORDER INFORMATION

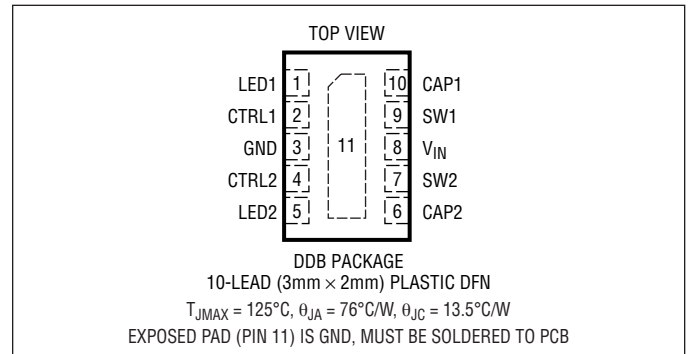

ORDER PART NUMBER	DDB PART MARKING
LT3497EDDB	LCGT
Order Options Tape and Reel: Add #TR Lead Free: Add #PBF Lead Free Tape and Reel: Add #TRPBF Lead Free Part Marking: http://www.linear.com/leadfree/	

Consult LTC Marketing for parts specified with wider operating temperature ranges.

ELECTRICAL CHARACTERISTICS

The ● denotes the specifications which apply over the full operating temperature range, otherwise specifications are at $T_A = 25^\circ\text{C}$. $V_{IN} = 3\text{V}$, $V_{CTRL1} = V_{CTRL2} = 3\text{V}$.

PARAMETER	CONDITIONS	MIN	TYP	MAX	UNITS
Minimum Operating Voltage		2.5			V
LED Current Sense Voltage ($V_{CAP1} - V_{LED1}$)	$V_{CAP1} = 16\text{V}$	● 190	200	210	mV
LED Current Sense Voltage ($V_{CAP2} - V_{LED2}$)	$V_{CAP2} = 16\text{V}$	● 190	200	210	mV
Offset Voltage (V_{OS}) Between ($V_{CAP1} - V_{LED1}$) - ($V_{CAP2} - V_{LED2}$) Voltages	$V_{OS} = (V_{CAP1} - V_{LED1}) - (V_{CAP2} - V_{LED2}) $	0	2	8	mV
CAP1, LED1 Pin Bias Current	$V_{CAP1} = 16\text{V}$, $V_{LED1} = 16\text{V}$		20	40	μA
CAP2, LED2 Pin Bias Current	$V_{CAP2} = 16\text{V}$, $V_{LED2} = 16\text{V}$		20	40	μA
V_{CAP1} , V_{LED1} Common Mode Minimum Voltage				2.5	V
V_{CAP2} , V_{LED2} Common Mode Minimum Voltage				2.5	V
Supply Current	$V_{CAP1} = V_{CAP2} = 16\text{V}$, $V_{LED1} = V_{LED2} = 15\text{V}$, $V_{CTRL1} = V_{CTRL2} = 3\text{V}$		6	8.5	mA
	$V_{CTRL1} = V_{CTRL2} = 0\text{V}$		12	18	μA
Switching Frequency		1.8	2.3	2.8	MHz
Maximum Duty Cycle		88	92		%
Converter 1 Switch Current Limit SW1		● 300	400		mA
Converter 2 Switch Current Limit SW2		● 300	400		mA
Converter 1 V_{CESAT}	$I_{SW1} = 200\text{mA}$		200		mV
Converter 2 V_{CESAT}	$I_{SW2} = 200\text{mA}$		200		mV
Switch 1 Leakage Current	$V_{SW1} = 16\text{V}$		0.1	5	μA
Switch 2 Leakage Current	$V_{SW2} = 16\text{V}$		0.1	5	μA

ELECTRICAL CHARACTERISTICS

The ● denotes the specifications which apply over the full operating temperature range, otherwise specifications are at $T_A = 25^\circ\text{C}$. $V_{IN} = 3\text{V}$, $V_{CTRL1} = V_{CTRL2} = 3\text{V}$.

PARAMETER	CONDITIONS		MIN	TYP	MAX	UNITS
V_{CTRL1} Voltage for Full LED Current	$V_{CAP1} = 16\text{V}$	●	1.5			V
V_{CTRL2} Voltage for Full LED Current	$V_{CAP2} = 16\text{V}$	●	1.5			V
V_{CTRL1} or V_{CTRL2} Voltage to Turn On the IC		●	100			mV
V_{CTRL1} and V_{CTRL2} Voltages to Shut Down the IC					50	mV
CTRL1, CTRL2 Pin Bias Current				100		nA
CAP1 Pin Overvoltage Protection		●	30	32	34	V
CAP2 Pin Overvoltage Protection		●	30	32	34	V
Schottky 1 Forward Drop	$I_{SCHOTTKY1} = 100\text{mA}$			0.8		V
Schottky 2 Forward Drop	$I_{SCHOTTKY2} = 100\text{mA}$			0.8		V
Schottky 1 Reverse Leakage Current	$V_{R1} = 25\text{V}$				4	μA
Schottky 2 Reverse Leakage Current	$V_{R2} = 25\text{V}$				4	μA

Note 1: Stresses beyond those listed under Absolute Maximum Ratings may cause permanent damage to the device. Exposure to any Absolute Maximum Rating condition for extended periods may affect device reliability and lifetime.

Note 2: The LT3497E is guaranteed to meet performance specifications from 0°C to 85°C . Specifications over the -40°C to 85°C operating temperature range are assured by design, characterization and correlation with statistical process controls.

TYPICAL PERFORMANCE CHARACTERISTICS ($T_A = 25^\circ\text{C}$ unless otherwise specified)

Switch Saturation Voltage (V_{CESAT})

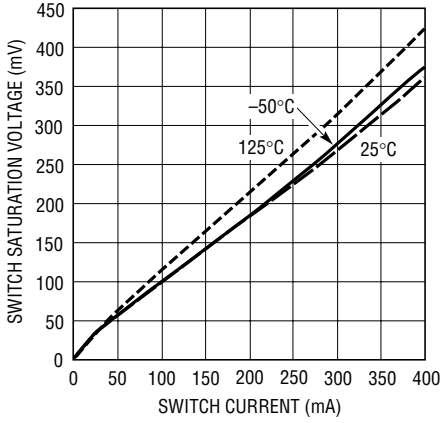

3497 G01

Schottky Forward Voltage Drop

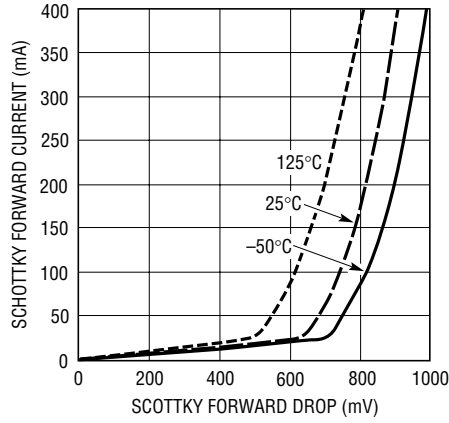

3497 G02

Shutdown Current ($V_{CTRL1} = V_{CTRL2} = 0\text{V}$)

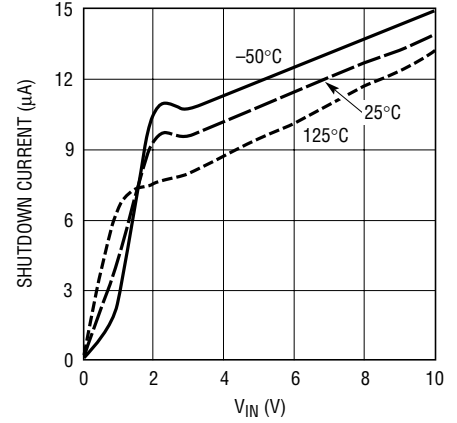

3497 G03

Sense Voltage ($V_{CAP} - V_{LED}$) vs V_{CTRL}

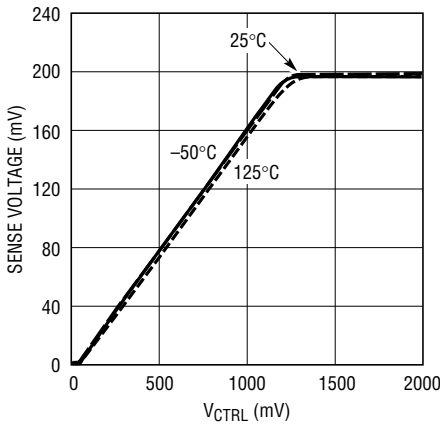

3497 G04

Open-Circuit Output Clamp Voltage

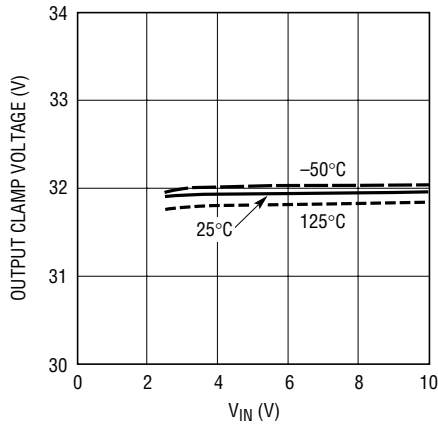

3497 G05

Input Current in Output Open Circuit

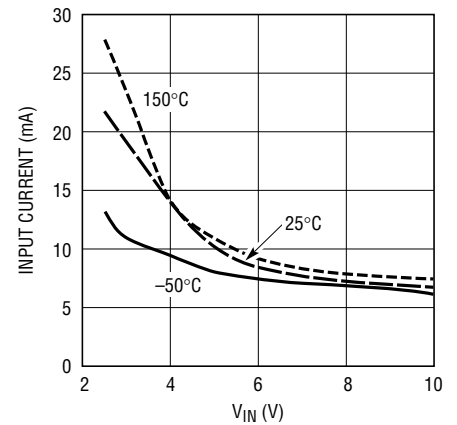

3497 G06

Switching Waveform

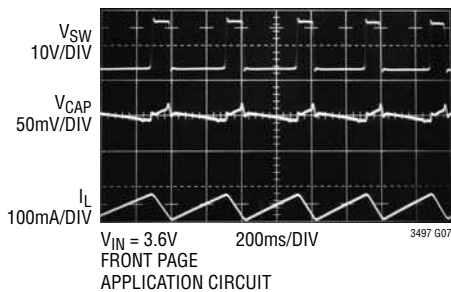

3497 G07

Transient Response

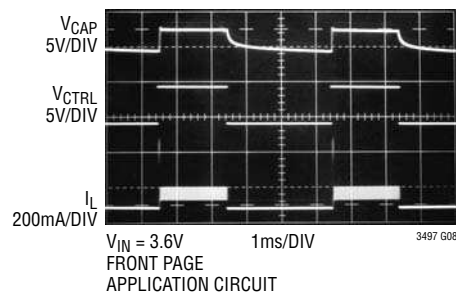

3497 G08

TYPICAL PERFORMANCE CHARACTERISTICS ($T_A = 25^\circ\text{C}$ unless otherwise specified)

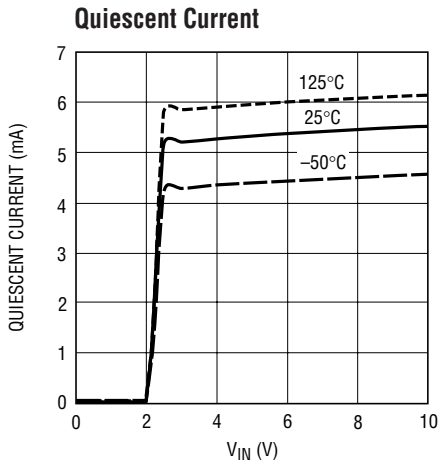

3497 G09

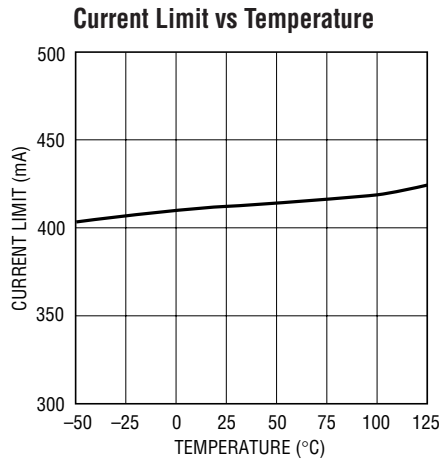

3497 G11

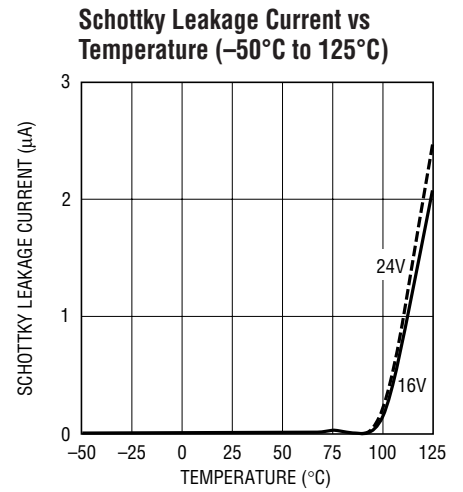

3497 G12

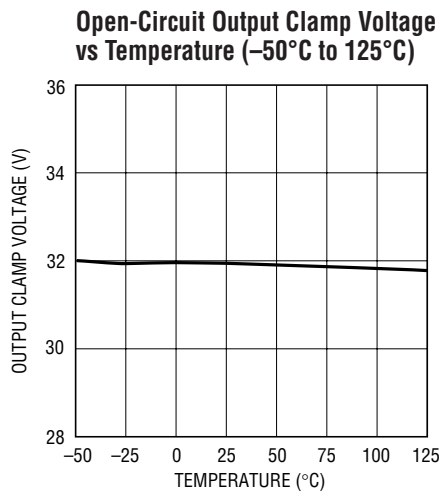

3497 G13

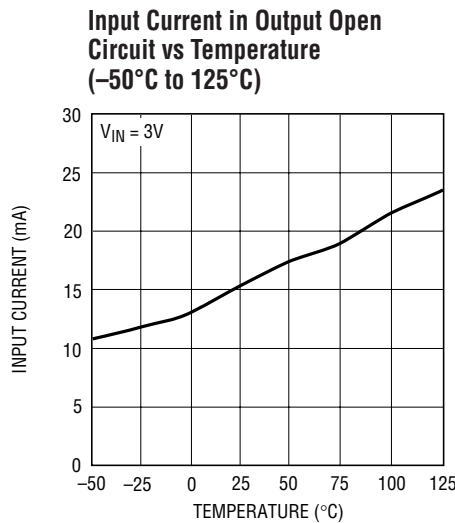

3497 G14

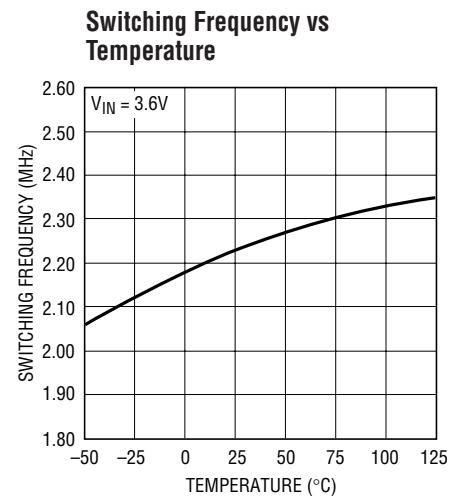

3497 G15

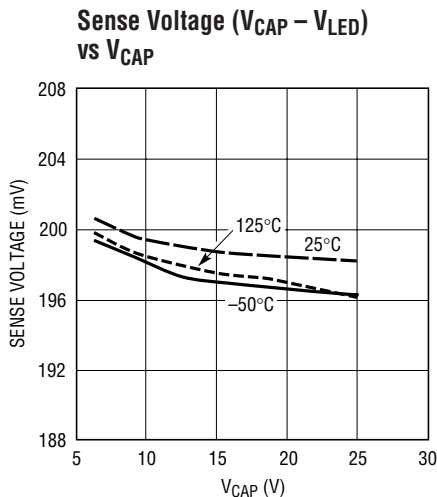

3497 G16

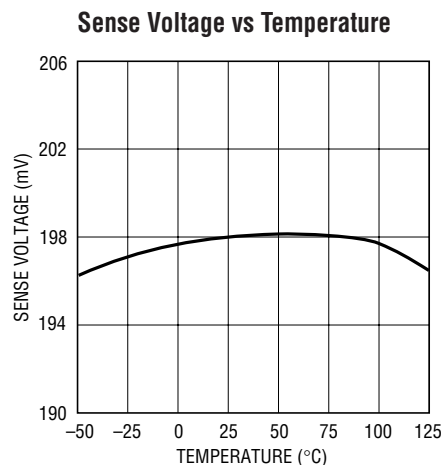

3497 G17

PIN FUNCTIONS

LED1 (Pin 1): Connection point for the anode of the first LED of the first set of LEDs and the sense resistor (R_{SENSE1}). The LED current can be programmed by:

$$I_{LED1} = \frac{200\text{mV}}{R_{SENSE1}}$$

CTRL1 (Pin 2): Dimming and Shutdown Pin. Connect CTRL1 below 50mV to disable converter 1. As the pin voltage is ramped from 0V to 1.5V, the LED current ramps from 0 to ($I_{LED1} = 200\text{mV}/R_{SENSE1}$). The CTRL1 pin must not be left floating.

GND (Pin 3): Connect the GND pin to the PCB system ground plane.

CTRL2 (Pin 4): Dimming and Shutdown Pin. Connect CTRL2 below 50mV to disable converter 2. As the pin voltage is ramped from 0V to 1.5V, the LED current ramps from 0 to ($I_{LED2} = 200\text{mV}/R_{SENSE2}$). The CTRL2 pin must not be left floating.

LED2 (Pin 5): Connection point for the anode of the first LED of the second set of LEDs and the sense resistor (R_{SENSE2}). The LED current can be programmed by:

$$I_{LED2} = \frac{200\text{mV}}{R_{SENSE2}}$$

CAP2 (Pin 6): Output of Converter 2. This pin is connected to the cathode of internal Schottky diode 2. Connect the output capacitor to this pin and the sense resistor (R_{SENSE2}) from this pin to LED2 pin.

SW2 (Pin 7): Switch Pin. Minimize trace area at this pin to minimize EMI. Connect the inductor at this pin.

V_{IN} (Pin 8): Input Supply Pin. This pin must be locally bypassed.

SW1 (Pin 9): Switch Pin. Minimize trace area at this pin to minimize EMI. Connect the inductor at this pin.

CAP1 (Pin 10): Output of Converter 1. This pin is connected to the cathode of internal Schottky diode 1. Connect the output capacitor to this pin and the sense resistor (R_{SENSE1}) from this pin to LED1 pin.

Exposed Pad (Pin 11): Ground. Must be soldered to PCB.

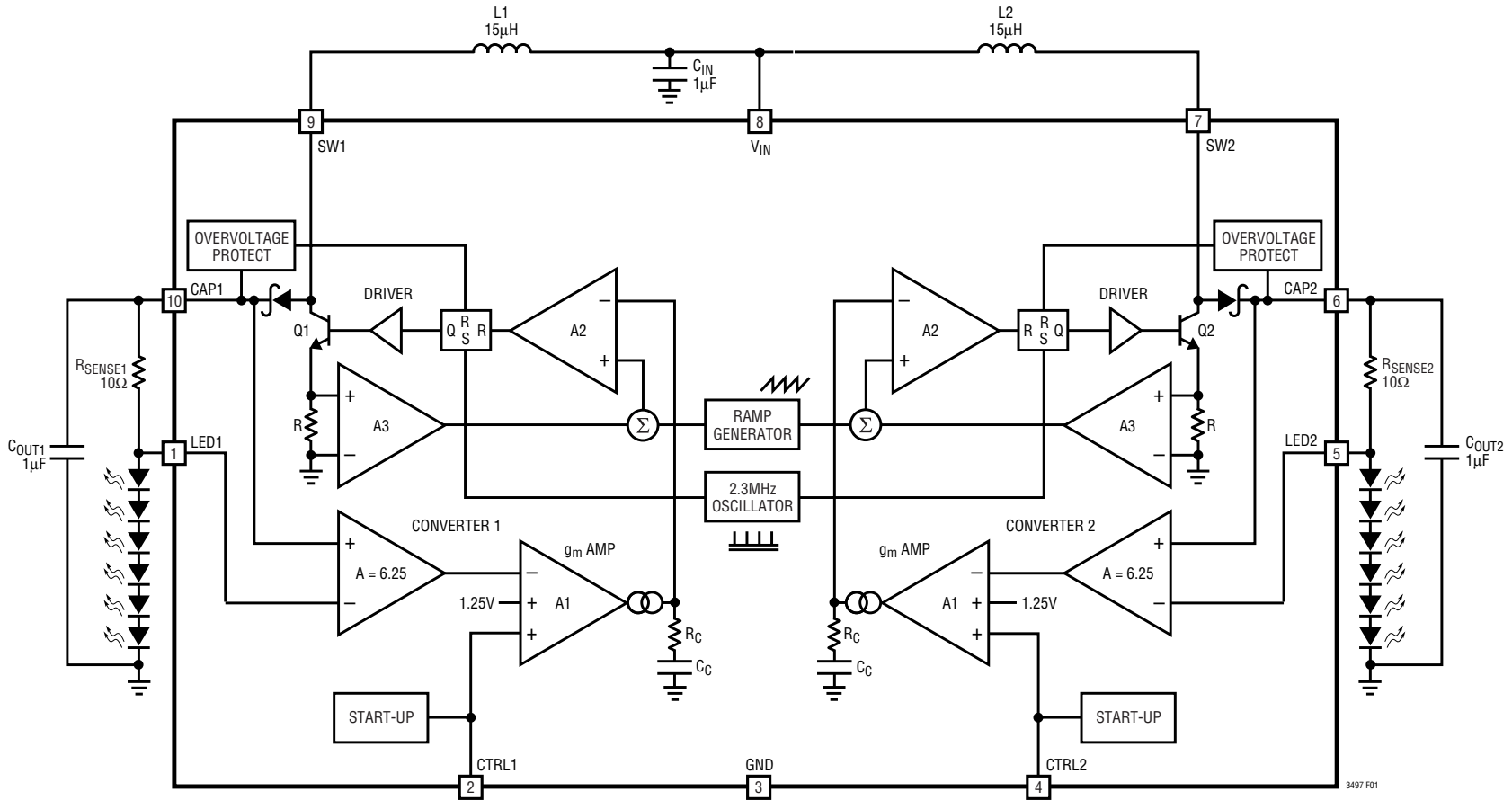

Figure 1. LT3497 Block Diagram

OPERATION

Main Control Loop

The LT3497 uses a constant frequency, current mode control scheme to provide excellent line and load regulation. It incorporates two identical, but fully independent PWM converters. Operation can be best understood by referring to the Block Diagram in Figure 1. The oscillator, start-up bias and the band gap reference are shared between the two converters. The control circuitry, power switch, Schottky diode etc., are identical for both the converters.

At power up, the capacitors at CAP1 and CAP2 pins are charged up to V_{IN} (input supply voltage) via their respective inductor and the internal Schottky diode. If either CTRL1 and CTRL2 or both are pulled higher than 100mV, the bandgap reference, the start-up bias and the oscillator are turned on.

The main control loop can be understood by following the operation of converter 1. At the start of each oscillator cycle, the power switch, Q1, is turned on. A voltage proportional to the switch current is added to a stabilizing ramp and the resulting sum is fed into the positive terminal of the PWM comparator, A2. When this voltage exceeds the level at the negative input of A2, the PWM logic turns off the power switch. The level at the negative input of A2 is set by the error amplifier, A1, and is simply an amplified version of the difference between the V_{CAP1} and V_{LED1} voltage and the bandgap reference. In this manner the error amplifier,

A1, sets the correct peak current level in inductor L1 to keep the output in regulation. The CTRL1 pin is used to adjust the LED current.

If only one of the converters is turned on, the other converter will stay off and its output will remain charged up to V_{IN} (input supply voltage). The LT3497 enters into shutdown when both CTRL1 and CTRL2 pins are pulled lower than 50mV. The CTRL1 and CTRL2 pins perform independent dimming and shutdown control for the two converters.

Minimum Output Current

The LT3497 can drive a 4-LED string at 2mA LED current without pulse skipping. As current is further reduced, the device may begin skipping pulses.

This will result in some low frequency ripple, although the average LED current remains regulated down to zero. The photo in Figure 2 details circuit operation driving 4 white LEDs at 2mA. Peak inductor current is less than 50mA and the regulator operates in discontinuous mode, meaning the inductor current reaches zero during the discharge phase. After the inductor current reaches zero, the SW pin exhibits ringing due to the LC tank circuit formed by the inductor in combination with the switch and the diode capacitance. This ringing is not harmful; far less spectral energy is contained in the ringing than in the switch transitions.

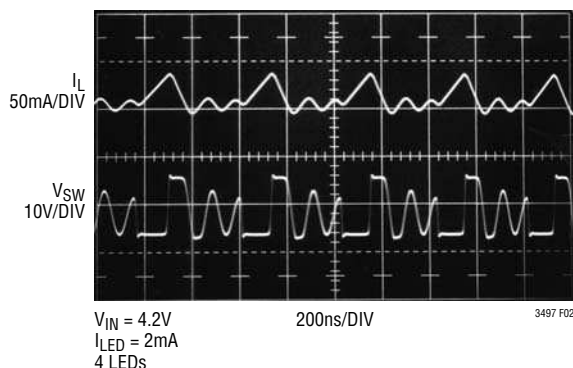

Figure 2. Switching Waveforms

APPLICATIONS INFORMATION

DUTY CYCLE

The duty cycle for a step-up converter is given by:

$$D = \frac{V_{OUT} + V_D - V_{IN}}{V_{OUT} + V_D - V_{CESAT}}$$

where:

V_{OUT} = Output voltage

V_D = Schottky forward voltage drop

V_{CESAT} = Saturation voltage of the switch

V_{IN} = Input voltage

The maximum duty cycle achievable for LT3497 is 88% when running at 2.3MHz switching frequency. Always ensure that the converter is not duty-cycle limited when powering the LEDs at a given frequency.

INDUCTOR SELECTION

A 15µH inductor is recommended for most LT3497 applications. Although small size and high efficiency are major concerns, the inductor should have low core losses at 2.3MHz and low DCR (copper wire resistance). Some inductors in this category with small size are listed in Table 1. The efficiency comparison of different inductors is shown in Figure 3.

Table 1: Recommended Inductors

PART	L (µH)	MAX DCR (Ω)	CURRENT RATING (mA)	VENDOR
LQH32CN150K53	15	0.58	300	Murata www.murata.com
LQH2MCN150K02	15	1.6	200	
LQH32CN100K53	10	0.3	450	
LQH2MCN100K02	10	1.2	225	
SD3112-150	15	0.654	440	Cooper www.cooperet.com
1001AS-150M (TYPE D312C)	15	0.80	360	Toko www.toko.com
CDRH2D11/HP	15	0.739	410	Sumida www.sumida.com

CAPACITOR SELECTION

The small size of ceramic capacitors make them ideal for LT3497 applications. Use only X5R and X7R types because they retain their capacitance over wider temperature ranges than other types such as Y5V or Z5U. A 1µF input capacitor

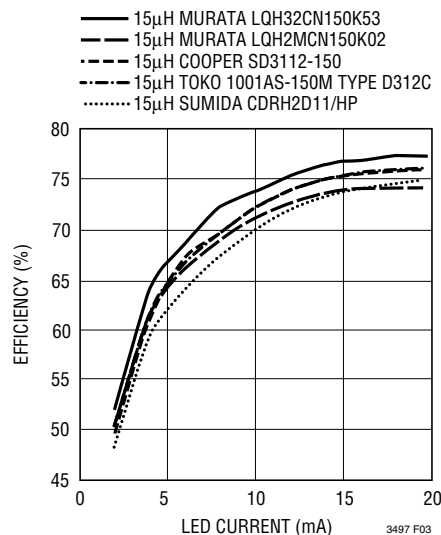

Figure 3. Efficiency Comparison of Different Inductors

and a 1µF output capacitor are sufficient for most applications. Table 2 shows a list of several ceramic capacitor manufacturers. Consult the manufacturers for detailed information on their entire selection of ceramic parts.

Table 2: Recommended Ceramic Capacitor Manufacturers

Taiyo Yuden	(800) 368-2496 www.t-yuden.com
AVX	(803) 448-9411 www.avxcorp.com
Murata	(714) 852-2001 www.murata.com

OVERVOLTAGE PROTECTION

The LT3497 has an internal open-circuit protection circuit for both converters. In the cases of output open circuit, when the LEDs are disconnected from the circuit or the LEDs fail open circuit, the converter V_{CAP} voltage is clamped at 32V (typ). Figure 4a shows the transient response of the front page application step-up converter with LED1 disconnected. With LED1 disconnected, the converter starts switching at the peak inductor current limit. The converter output starts ramping up and finally gets clamped at 32V (typ). The converter will then switch at low inductor current to regulate the converter output at the clamp voltage. The V_{CAP} and input current during output open circuit are shown in the Typical Performance Characteristics.

APPLICATIONS INFORMATION

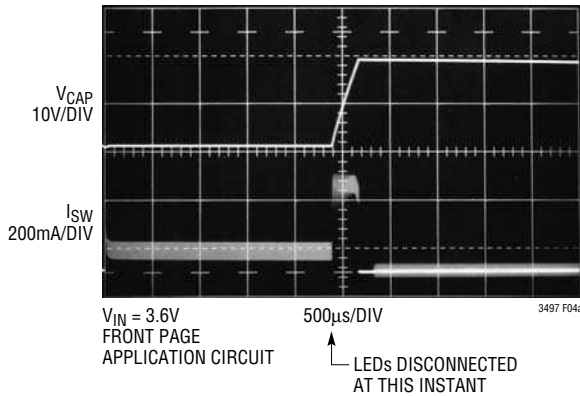

Figure 4a. Transient Response of Switcher 1 with LED1 Disconnected from the Output

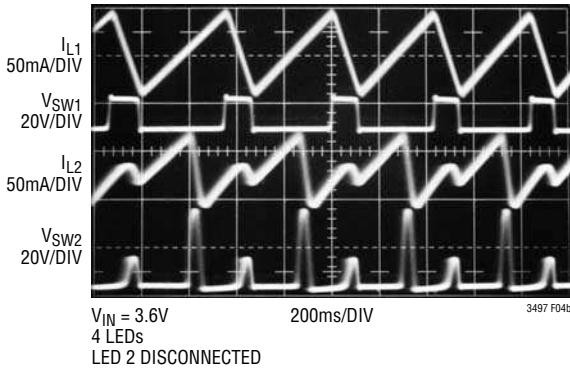

Figure 4b. Switching Waveforms with Output 1 Open Circuit

In the event one of the converters has an output open circuit, its output voltage will be clamped at 32V. However, the other converter will continue functioning properly. The photo in Figure 4b shows circuit operation with converter 2 output open circuit and converter 1 driving 4 LEDs at 20mA. Converter 2 starts switching at a lower peak inductor current and begins skipping pulses, thereby reducing its input current.

INRUSH CURRENT

The LT3497 has built-in Schottky diodes. When supply voltage is applied to the V_{IN} pin, an inrush current flows through the inductor and the Schottky diode and charges up the CAP voltage. Both the Schottky diodes in the LT3497 can sustain a maximum current of 1A. The selection of inductor and capacitor value should ensure the peak of the inrush current to be below 1A.

For low DCR inductors, which are usually the case for this application, the peak inrush current can be simplified as follows:

$$\alpha = \frac{r}{2 \cdot L}$$

$$\omega = \sqrt{\frac{1}{L \cdot C} - \frac{r^2}{4 \cdot L^2}}$$

$$I_{PK} = \frac{V_{IN} - 0.6}{L \cdot \omega} \cdot \exp\left(-\frac{\alpha}{\omega} \cdot \frac{\pi}{2}\right)$$

where L is the inductance, r is the DCR of the inductor and C is the output capacitance.

Table 3 gives inrush peak currents for some component selections.

Table 3: Inrush Peak Currents

V_{IN} (V)	r (Ω)	L (μ H)	C_{OUT} (μ F)	I_P (A)
4.2	0.58	15	1	0.828
4.2	1.6	15	1	0.682
4.2	0.8	15	1	0.794
4.2	0.739	15	1	0.803

PROGRAMMING LED CURRENT

The LED current of each LED string can be set independently by the choice of resistors R_{SENSE1} and R_{SENSE2} , respectively. For each LED string, the feedback resistor (R_{SENSE}) and the sense voltage ($V_{CAP} - V_{LED}$) control the LED current.

For each independent LED string, the CTRL pin controls the sense reference voltage as shown in the Typical Performance Characteristics. For CTRL higher than 1.5V, the sense reference is 200mV, which results in full LED current. In order to have accurate LED current, precision resistors are preferred (1% is recommended). The formula and Table 4 for R_{SENSE} selection are shown below.

$$R_{SENSE} = \frac{200mV}{I_{LED}}$$

APPLICATIONS INFORMATION

Table 4: R_{SENSE} Value Selection for 200mV Sense

I _{LED} (mA)	R _{SENSE} (Ω)
5	40
10	20
15	13.3
20	10

DIMMING CONTROL

There are three different types of dimming control circuits. The LED current can be set by modulating the CTRL pin with a DC voltage, a filtered PWM signal or directly with a PWM signal.

Using a DC Voltage

For some applications, the preferred method of brightness control is a variable DC voltage to adjust the LED current. The CTRL pin voltage can be modulated to set the dimming of the LED string. As the voltage on the CTRL pin increases from 0V to 1.5V, the LED current increases from 0 to I_{LED}. As the CTRL pin voltage increases beyond 1.5V, it has no effect on the LED current.

The LED current can be set by:

$$I_{LED} \approx \frac{200mV}{R_{SENSE}} \text{ when } V_{CTRL} > 1.5V$$

$$I_{LED} \approx \frac{V_{CTRL}}{6.25 \cdot R_{SENSE}} \text{ when } V_{CTRL} < 1.25V$$

Feedback voltage variation versus control voltage is given in the Typical Performance Characteristics.

Using a Filtered PWM Signal

A filtered PWM can be used to control the brightness of the LED string. The PWM signal is filtered (Figure 5) by an RC network and fed to the CTRL1, CTRL2 pins.

The corner frequency of R1, C1 should be much lower than the frequency of the PWM signal. R1 needs to be much smaller than the internal impedance in the CTRL pins which is 10MΩ (typ).

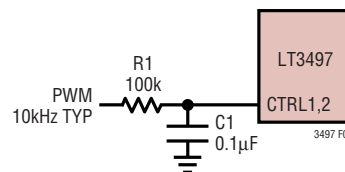

Figure 5. Dimming Control Using a Filtered PWM Signal

Direct PWM Dimming

Changing the forward current flowing in the LEDs not only changes the intensity of the LEDs, it also changes the color. The chromaticity of the LEDs changes with the change in forward current. Many applications cannot tolerate any shift in the color of the LEDs. Controlling the intensity of the LEDs with a direct PWM signal allows dimming of the LEDs without changing the color. In addition, direct PWM dimming offers a wider dimming range to the user.

Dimming the LEDs via a PWM signal essentially involves turning the LEDs on and off at the PWM frequency. The typical human eye has a limit of ~60 frames per second. By increasing the PWM frequency to ~80Hz or higher, the eye will interpret that the pulsed light source is continuously on. Additionally, by modulating the duty cycle (amount of “on time”) the intensity of the LEDs can be controlled. The color of the LEDs remains unchanged in this scheme since the LED current value is either zero or a constant value.

Figure 6 shows a Li-ion powered 4/4 white LED driver. Direct PWM dimming method requires an external NMOS tied between the cathode of the lowest LED in the string and ground as shown in Figure 6. Si2318DS MOSFETs can be used since its sources are connected to ground. The PWM signal is applied to the (CTRL1 and CTRL2) control pins of the LT3497 and the gate of the MOSFET. The PWM signal should traverse between 0V to 5V to ensure proper turn on and off of the converters and the NMOS transistors (Q1 and Q2). When the PWM signal goes high, LEDs are connected to ground and a current of I_{LED} = (200mV/R_{SENSE}) flows through the LEDs. When the PWM signal goes low, the LEDs are disconnected and turn off. The low PWM input applied to the LT3497 ensures that the respective

APPLICATIONS INFORMATION

converter turns off. The MOSFETs ensure that the LEDs quickly turn off without discharging the output capacitors which in turn allows the LEDs to turn on faster. Figures 7 and 8 show the PWM dimming waveforms and efficiency for the Figure 6 circuit.

The time it takes for the LEDs current to reach its programmed value sets the achievable dimming range for a given PWM frequency. For example, the settling time of the LEDs current in Figure 7 is approximately 40µs for a 3V input voltage. The achievable dimming range for this application and 100Hz PWM frequency can be determined using the following method.

Example:

$$f = 100\text{Hz}, t_{\text{SETTLE}} = 40\mu\text{s}$$

$$t_{\text{PERIOD}} = 1/f = 1/100 = 0.01\text{s}$$

$$\text{Dim Range} = t_{\text{PERIOD}}/t_{\text{SETTLE}} = 0.01\text{s}/40\mu\text{s} = 250:1$$

$$\begin{aligned} \text{Min Duty Cycle} &= t_{\text{SETTLE}}/t_{\text{PERIOD}} \cdot 100 \\ &= 40\mu\text{s}/0.01\text{s} = 0.4\% \end{aligned}$$

$$\text{Duty Cycle Range} = 100\% \rightarrow 0.4\% \text{ at } 100\text{Hz}$$

The calculations show that for a 100Hz signal the dimming range is 250 to 1. In addition, the minimum PWM duty cycle of 0.4% ensures that the LEDs current has enough

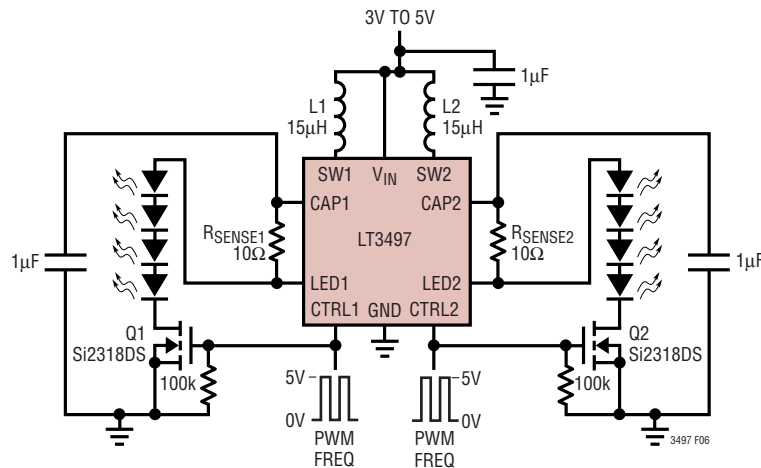

Figure 6. Li-Ion to 4/4 White LEDs with Direct PWM Dimming

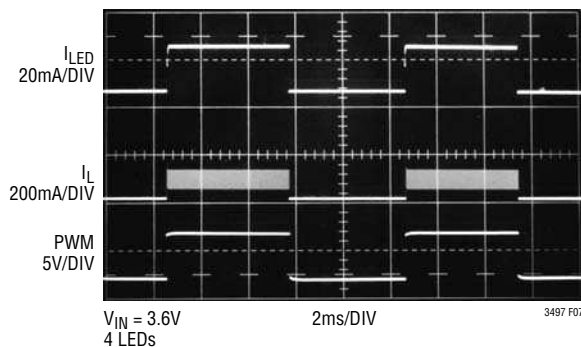

Figure 7. Direct PWM Dimming Waveforms

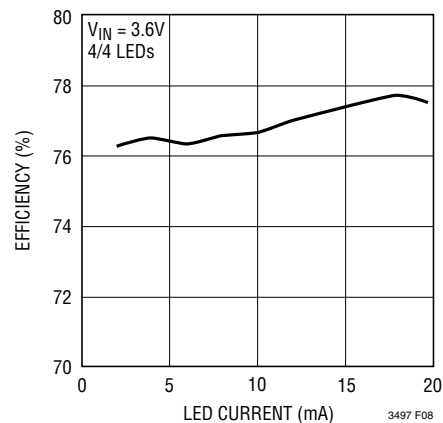

Figure 8. Efficiency

APPLICATIONS INFORMATION

time to settle to its final value. Figure 9 shows the available dimming range for different PWM frequencies with a settling time of 40μs.

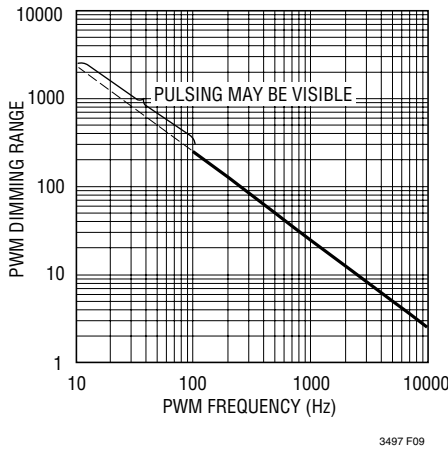

Figure 9. Dimming Ratio vs Frequency

The dimming range can be further extended by changing the amplitude of the PWM signal. The height of the PWM signal sets the commanded sense voltage across the sense resistor through the CTRL pin. In this manner both analog dimming and direct PWM dimming extend the dimming range for a given application. The color of the LEDs no longer remains constant because the forward current of the LED changes with the height of the CTRL signal. For the 4-LED application described above, the LEDs can be dimmed first, modulating the duty cycle of the PWM signal. Once the minimum duty cycle is reached, the height of the PWM signal can be decreased below 1.5V down to 100mV. The use of both techniques together allows the average LED current for the 4-LED application to be varied from 20mA down to less than 20μA. Figure 10 shows the application for dimming using both analog dimming and PWM dimming. A potentiometer must be added to ensure that the gate of the NMOS receives a logic-level signal, while the CTRL signal can be adjusted to lower amplitudes.

LOW INPUT VOLTAGE APPLICATIONS

The LT3497 can be used in low input voltage applications. The input supply voltage to the LT3497 must be 2.5V or higher. However, the inductors can be run off a

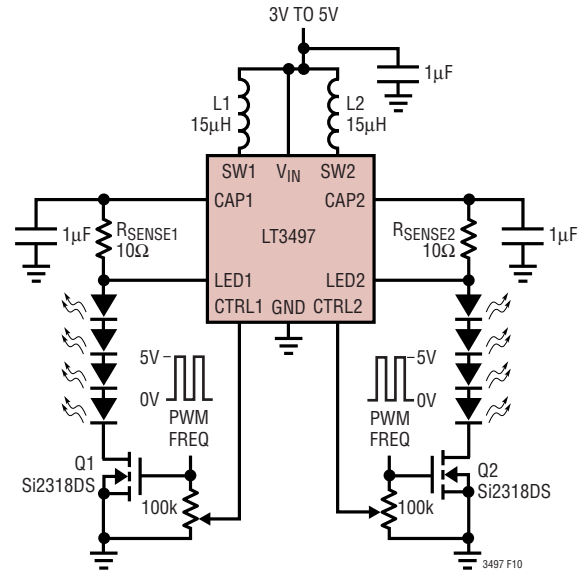

Figure 10. Li-Ion to 4/4 White LEDs with Both PWM Dimming and Analog Dimming

lower battery voltage. This technique allows the LEDs to be powered off two alkaline cells. Most portable devices have a 3.3V supply voltage which can be used to power the LT3497. The LEDs can be driven straight from the battery, resulting in higher efficiency.

Figure 11 shows 3/3 LEDs powered by two AA cells. The battery is connected to the inductors and the chip is powered off a 3.3V logic supply voltage.

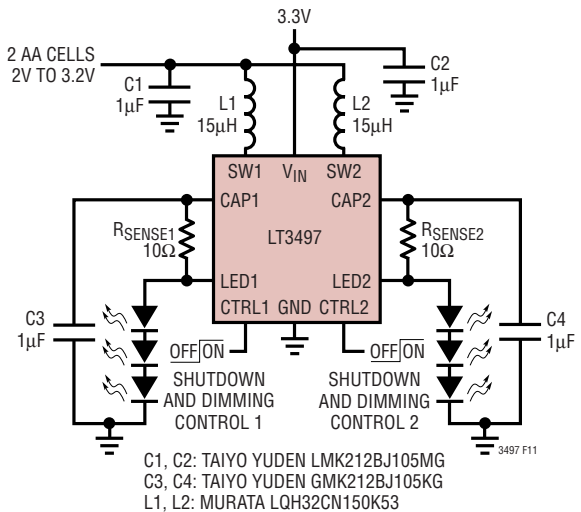

Figure 11. 2 AA Cells to 3/3 White LEDs

APPLICATIONS INFORMATION

BOARD LAYOUT CONSIDERATIONS

As with all switching regulators, careful attention must be paid to the PCB board layout and component placement. To prevent electromagnetic interference (EMI) problems, proper layout of high frequency switching paths is essential. Minimize the length and area of all traces connected to the switching node pins (SW1 and SW2). Keep the sense voltage pins (CAP1, CAP2, LED1 and LED2) away from

the switching node. Place the output capacitors (C_{OUT1} and C_{OUT2}) next to the output pins (CAP1 and CAP2). The placement of a bypass capacitor on V_{IN} needs to be in close proximity to the IC to filter EMI noise from SW1 and SW2. Always use a ground plane under the switching regulator to minimize interplane coupling. Recommended component placement is shown in Figure 12.

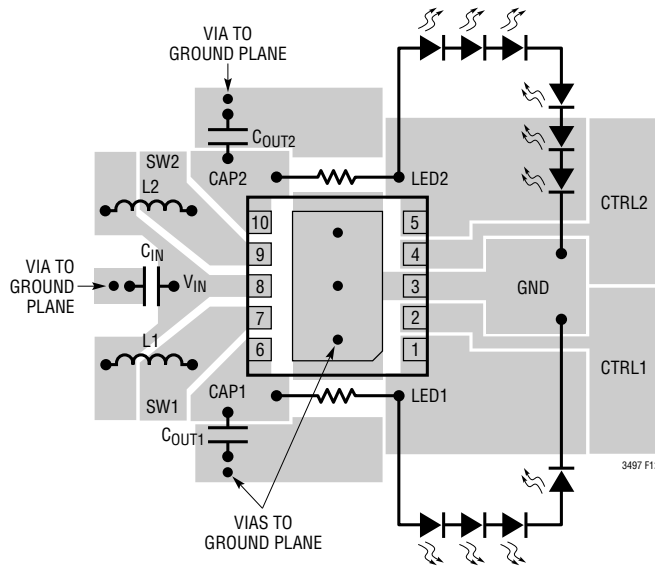
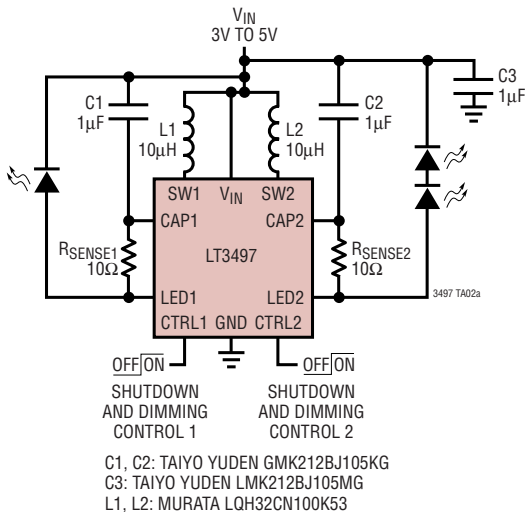

Figure 12. Recommended Component Placement

TYPICAL APPLICATIONS

Li-Ion to 1/2 White LEDs



Conversion Efficiency

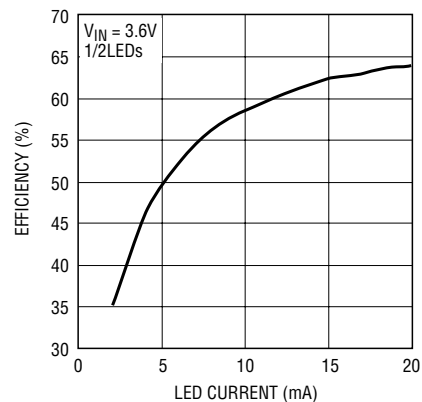

3497 TA02b

TYPICAL APPLICATIONS

Li-Ion to 2/4 White LEDs

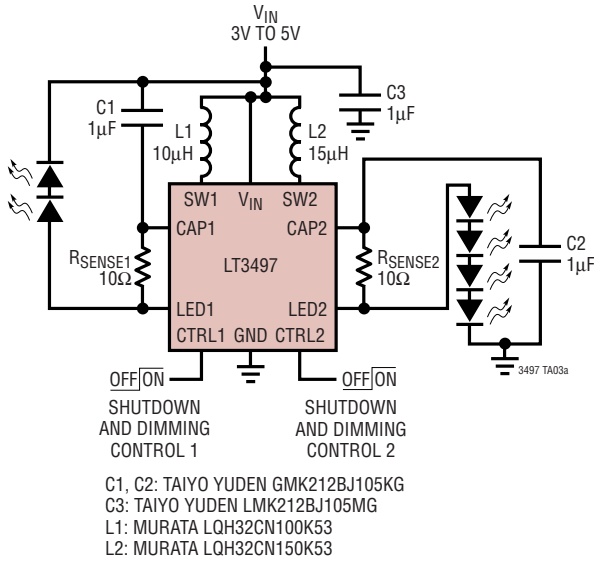

Conversion Efficiency

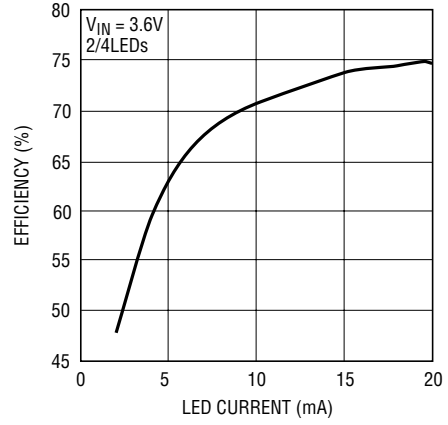

3497 TA03b

Li-Ion to 3/3 White LEDs

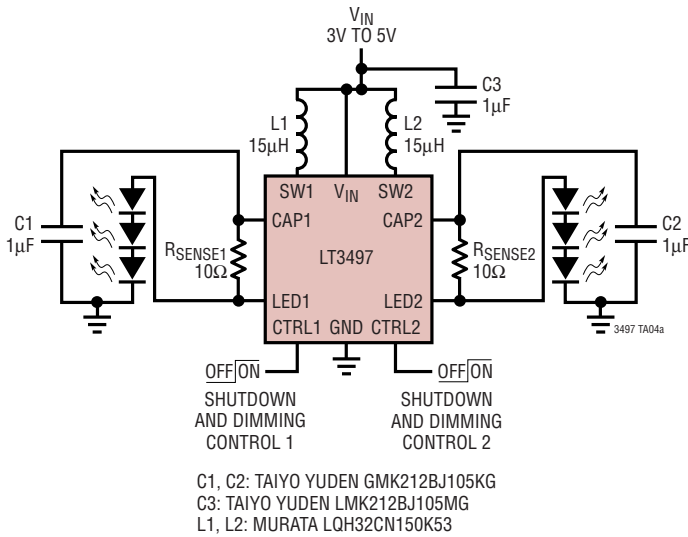

Conversion Efficiency

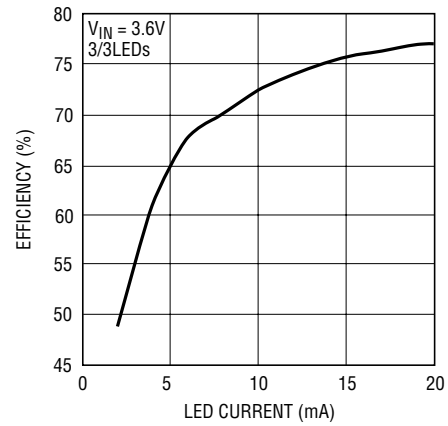

3497 TA04b

TYPICAL APPLICATIONS

Li-Ion to 4/6 White LEDs

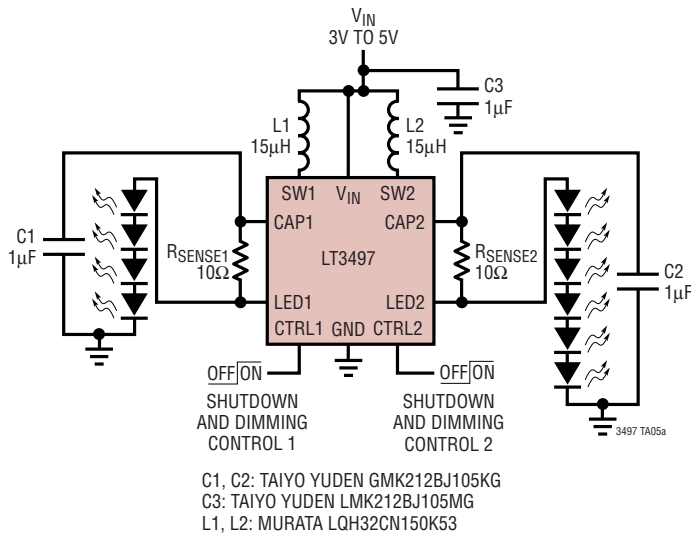

Conversion Efficiency

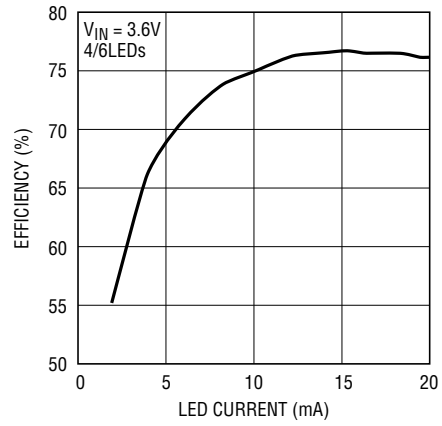

3497 TA05b

Li-Ion to 5/5 White LEDs

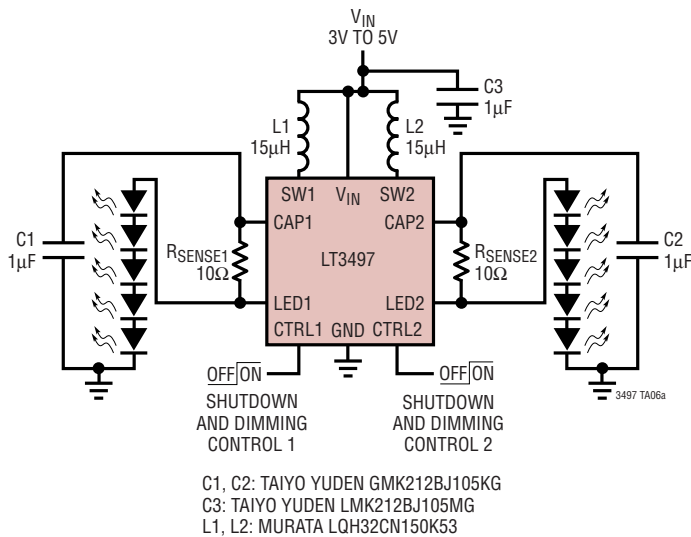

Conversion Efficiency

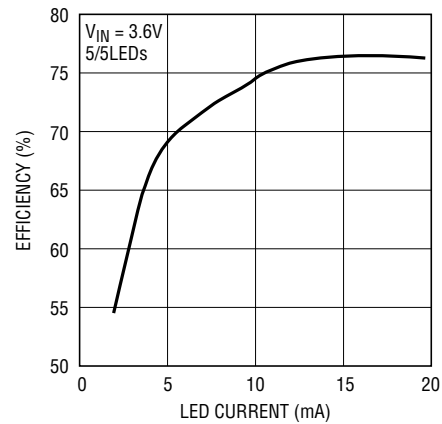

3497 TA06b

PACKAGE DESCRIPTION

DDB Package
10-Lead Plastic DFN (3mm × 2mm)
 (Reference LTC DWG # 05-08-1722 Rev 0)

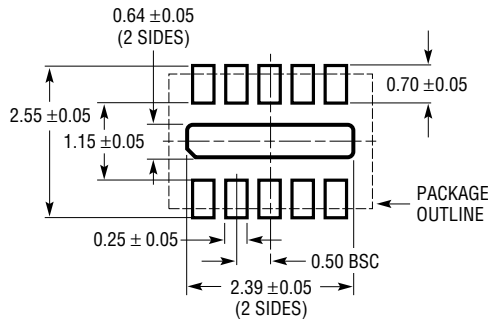

RECOMMENDED SOLDER PAD PITCH AND DIMENSIONS

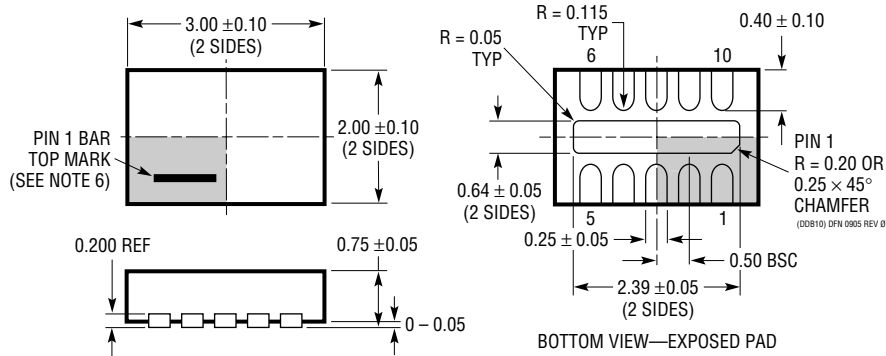

- NOTE:
1. DRAWING CONFORMS TO VERSION (WECD-1) IN JEDEC PACKAGE OUTLINE M0-229
 2. DRAWING NOT TO SCALE
 3. ALL DIMENSIONS ARE IN MILLIMETERS
 4. DIMENSIONS OF EXPOSED PAD ON BOTTOM OF PACKAGE DO NOT INCLUDE MOLD FLASH. MOLD FLASH, IF PRESENT, SHALL NOT EXCEED 0.15mm ON ANY SIDE
 5. EXPOSED PAD SHALL BE SOLDER PLATED
 6. SHADED AREA IS ONLY A REFERENCE FOR PIN 1 LOCATION ON THE TOP AND BOTTOM OF PACKAGE

TYPICAL APPLICATION

2 Li-Ion to 8/8 White LEDs

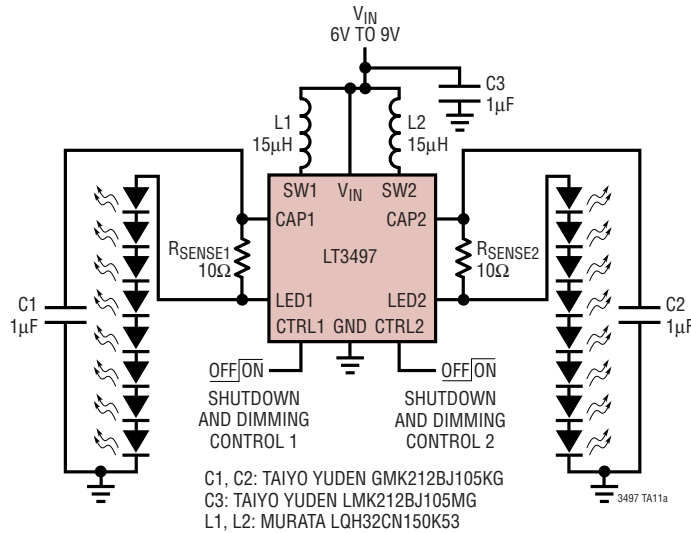

Conversion Efficiency

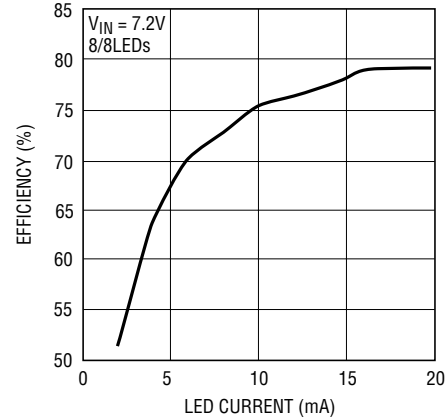

3497 TA11b

RELATED PARTS

PART NUMBER	DESCRIPTION	COMMENTS
LT1937	Constant Current, 1.2MHz, High Efficiency White LED Boost Regulator	Up to 4 White LEDs, V_{IN} : 2.5V to 10V, $V_{OUT(MAX)}$ = 34V, I_Q = 1.9mA, I_{SD} < 1µA, ThinSOT™/SC70 Packages
LTC3200-5	Low Noise, 2MHz Regulated Charge Pump White LED Driver	Up to 6 White LEDs, V_{IN} : 2.7V to 4.5V, I_Q = 8mA, I_{SD} < 1µA, ThinSOT Package
LTC3201	Low Noise, 1.7MHz Regulated Charge Pump White LED Driver	Up to 6 White LEDs, V_{IN} : 2.7V to 4.5V, I_Q = 6.5mA, I_{SD} < 1µA, MS Package
LTC3202	Low Noise, 1.5MHz Regulated Charge Pump White LED Driver	Up to 8 White LEDs, V_{IN} : 2.7V to 4.5V, I_Q = 5mA, I_{SD} < 1µA, MS Package
LTC3205	High Efficiency, Multidisplay LED Controller	Up to 4 (Main), 2 (Sub) and RGB, V_{IN} : 2.8V to 4.5V, I_Q = 50µA, I_{SD} < 1µA, 24-Lead QFN Package
LT3465/LT3465A	Constant Current, 1.2MHz/2.7MHz, High Efficiency White LED Boost Regulator with Integrated Schottky Diode	Up to 6 White LEDs, V_{IN} : 2.7V to 16V, $V_{OUT(MAX)}$ = 34V, I_Q = 1.9mA, I_{SD} < 1µA, ThinSOT Package
LT3466/LT3466-1	Dual Full Function, 2MHz Diodes White LED Step-Up Converter with Built-In Schottkys	Up to 20 White LEDs, V_{IN} : 2.7V to 24V, $V_{OUT(MAX)}$ = 39V, DFN, TSSOP-16 Packages
LT3486	Dual 1.3A White LED Converter with 1000:1 True Color PWM Dimming	Drives Up to 16 100mA White LEDs. V_{IN} : 2.5V to 24V, $V_{OUT(MAX)}$ = 36V, DFN, TSSOP Packages
LT3491	White LED Driver in SC70 with Integrated Schottky	Drives Up to 6 20mA White LEDs, V_{IN} : 2.5V to 12V, $V_{OUT(MAX)}$ = 27V, 8-Lead SC70 Package

ThinSOT is a trademark of Linear Technology Corporation.