

**OBSOLETE PRODUCT**  
**DATA SHEET FOR REFERENCE ONLY**

 Consult [www.linear.com](http://www.linear.com) for possible alternate source.

**FEATURES**

- *Guaranteed* 0.8% Initial Tolerance
- *Guaranteed* 0.4% Load Regulation
- *Guaranteed* 10A Output Current
- 100% Thermal Limit Burn-In
- 24A Transient Output Current
- Standard Adjustable Pinout
- Operates to 35V

**APPLICATIONS**

- System Power Supplies
- High Power Linear Regulator
- Battery Chargers
- Power Driver
- Constant Current Regulator

**DESCRIPTION**

The LT<sup>®</sup>1038 is a three terminal regulator which is capable of providing in excess of 10A output current over 1.2V to 32V range. The device is packaged in a standard TO-3 power package and is plug-in compatible with industry standard adjustable regulators, such as the LM117 and LM138. Also, the LT1038 is a functional replacement for the LM396.

In addition to excellent load and line regulations, the LT1038 is fully protected by current limiting, safe area protection and thermal shutdown. New current limiting circuitry allows transient load currents up to 24A to be supplied for 500 $\mu$ s without causing the regulator to current limit and drop out of regulation during the transient.

On-chip trimming of initial reference voltage to  $\pm 0.8\%$  combined with 0.4% load regulation minimize errors in all high current applications. Further, the LT1038 is manufactured with standard bipolar processing and has Linear Technology's high reliability.

 LTC and LT are registered trademarks of Linear Technology Corporation.

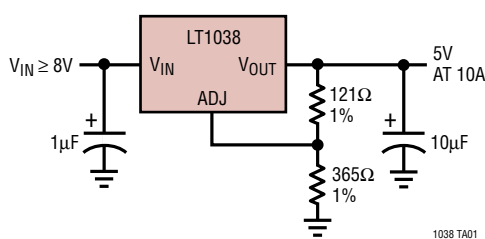
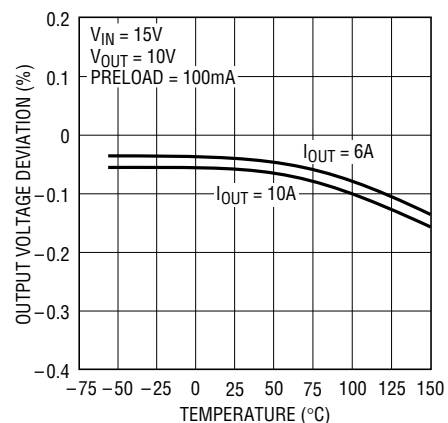
**TYPICAL APPLICATIONS**
**5V, 10A Regulator**

**Load Regulation**

1038 TA02

# LT1038

## ABSOLUTE MAXIMUM RATINGS

(Note 1)

Power Dissipation .....	Internally Limited
Input to Output Voltage Differential .....	35V
Operating Junction Temperature Range	
LT1038M Control Circuitry .....	-55°C to 150°C
LT1038M Power Transistor .....	-55°C to 200°C
LT1038C Control Circuitry .....	0°C to 125°C
LT1038C Power Transistor .....	0°C to 175°C
Storage Temperature Range .....	-65°C to 150°C
Lead Temperature (Soldering, 10 sec).....	300°C

## PACKAGE/ORDER INFORMATION

**OBSELETE PACKAGE**

ORDER PART NUMBER
LT1038MK LT1038CK

## PRECONDITIONING 100% Thermal Limit Burn-in

## ELECTRICAL CHARACTERISTICS

The ● denotes the specifications which apply over the full operating temperature range, otherwise specifications are at  $T_A = 25^\circ\text{C}$ . (Note 2)

SYMBOL	PARAMETER	CONDITIONS	LT1038M			LT1038C			UNITS
			MIN	TYP	MAX	MIN	TYP	MAX	
$V_{REF}$	Reference Voltage	$I_{OUT} = 20\text{mA}$ , $T_j = 25^\circ\text{C}$	1.24	1.25	1.26	1.23	1.25	1.275	V
		$3\text{V} \leq (V_{IN} - V_{OUT}) \leq 35\text{V}$ $20\text{mA} \leq I_{OUT} \leq 10\text{A}$ , $P \leq 75\text{W}$	● 1.22	1.25	1.285	1.22	1.25	1.285	V
$\frac{\Delta V_{OUT}}{\Delta V_{IN}}$	Line Regulation	$3\text{V} \leq (V_{IN} - V_{OUT}) \leq 35\text{V}$ , $I_{OUT} = 20\text{mA}$ (Note 3)	●	0.005 0.02	0.01 0.03	0.005	0.02 0.03		%/V %/V
$\frac{\Delta V_{OUT}}{\Delta I_{OUT}}$	Load Regulation	$20\text{mA} \leq I_{OUT} \leq 10\text{A}$ (Note 3) $3\text{V} \leq (V_{IN} - V_{OUT}) \leq 35\text{V}$ $3\text{V} \leq (V_{IN} - V_{OUT}) \leq 35\text{V}$	●	0.1 0.3	0.4 0.8	0.1	0.6 1.0		% %
	Thermal Regulation	20ms Pulse		0.002	0.005	0.002	0.01		%/W
	Ripple Rejection	$V_{OUT} = 10\text{V}$ , $f = 120\text{Hz}$ $C_{ADJ} = 0\mu\text{F}$ $C_{ADJ} = 10\mu\text{F}$	● ● 60	60 75		60	75		dB dB
$I_{ADJ}$	Adjust Pin Current		●	50	100	50	100		$\mu\text{A}$
$\Delta I_{ADJ}$	Adjust Pin Current Change	$20\text{mA} \leq I_{OUT} \leq 10\text{A}$ $3\text{V} \leq (V_{IN} - V_{OUT}) \leq 35\text{V}$	●	0.2	3	0.2	3		$\mu\text{A}$
	Minimum Load Current	$(V_{IN} - V_{OUT}) = 35\text{V}$ $(V_{IN} - V_{OUT}) \leq 20\text{V}$	● ●	7	20 10	7	20 10		mA mA
$I_{SC}$	Current Limit	$(V_{IN} - V_{OUT}) \leq 10\text{V}$ DC Transient (0.5ms)	●	10 14	14 22	10 12	14 22		A A
		$(V_{IN} - V_{OUT}) = 30\text{V}$ , $T_j = 25^\circ\text{C}$		1	2	1	2		A
$\frac{\Delta V_{OUT}}{\Delta \text{Temp}}$	Temperature Stability		●	1	2	1			%
$\frac{\Delta V_{OUT}}{\Delta \text{Time}}$	Long Term Stability	$T_A = 125^\circ\text{C}$ , 1000 Hours		0.3	1	0.3	1		%
$e_n$	RMS Output Noise (% of $V_{OUT}$ )	$10\text{Hz} \leq f \leq 10\text{kHz}$		0.001		0.001			%
$\theta_{JC}$	Thermal Resistance Junction to Case	Power Transistor Control Circuitry	●		1 0.5		1 0.5		$^\circ\text{C/W}$ $^\circ\text{C/W}$

## ELECTRICAL CHARACTERISTICS

**Note 1:** Absolute Maximum Ratings are those values beyond which the life of a device may be impaired.

**Note 2:** Unless otherwise specified, these specifications apply:  $V_{IN} - V_{OUT} = 5V$  and  $I_{OUT} = 5A$ . These specifications are applicable for power dissipations up to 75W. At input-output voltage differentials greater

than 10V, achievable output current and power dissipation decrease due to protection circuitry.

**Note 3:** See thermal regulation specifications for changes in output voltage due to heating effects. Load and line regulation are measured at a constant junction temperature by low duty cycle pulse testing.

## TYPICAL PERFORMANCE CHARACTERISTICS

Dropout Voltage

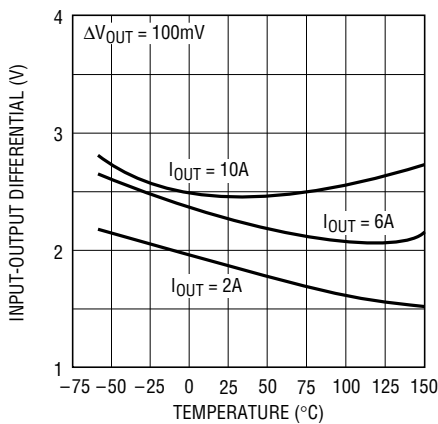

1038 TA02

Adjustment Current

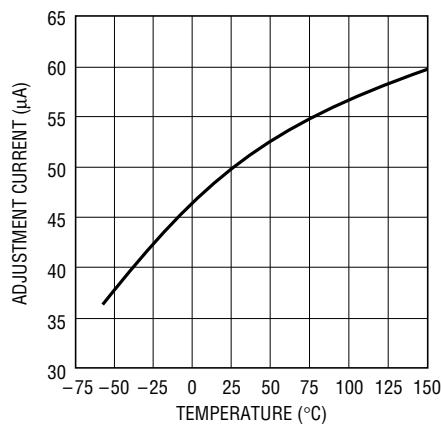

1038 G02

Temperature Stability

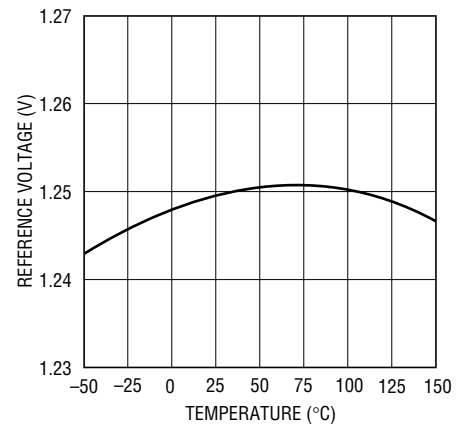

1038 G03

Output Impedance

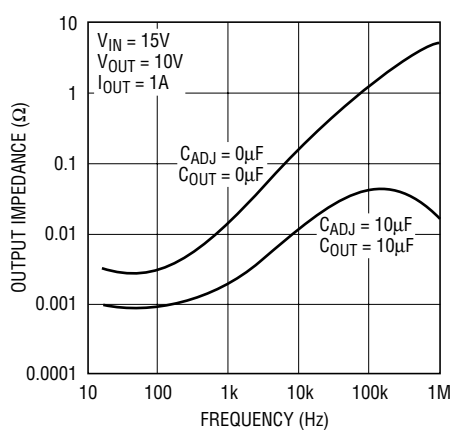

1038 G04

Minimum Operating Current

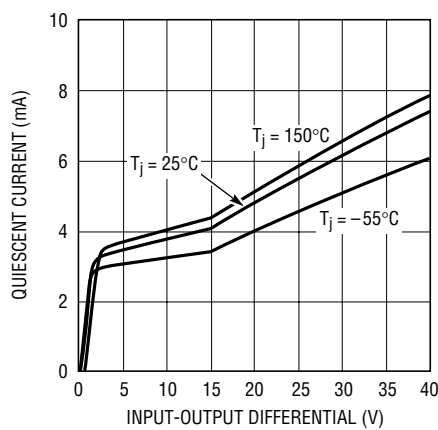

1038 G05

Ripple Rejection

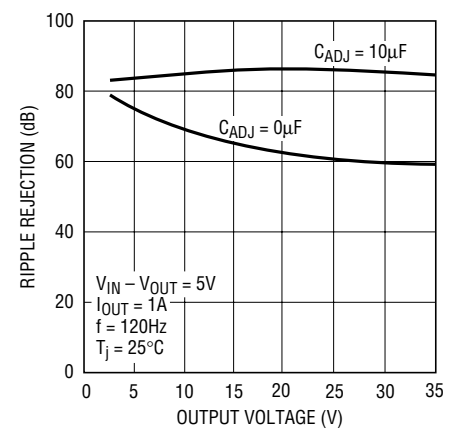

1038 G06

TYPICAL PERFORMANCE CHARACTERISTICS

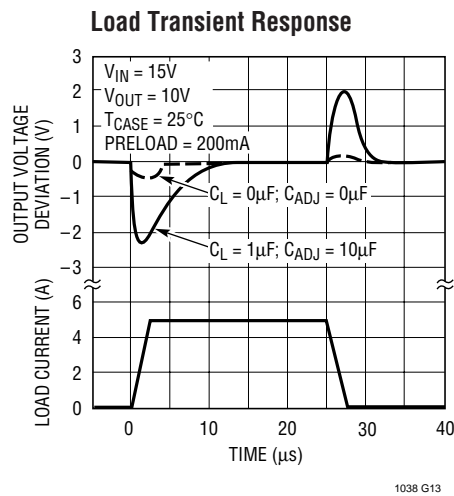
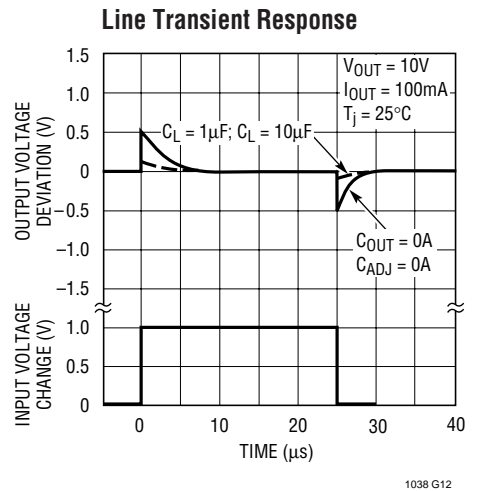
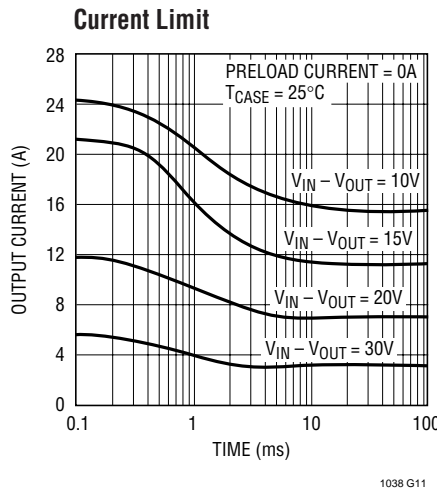
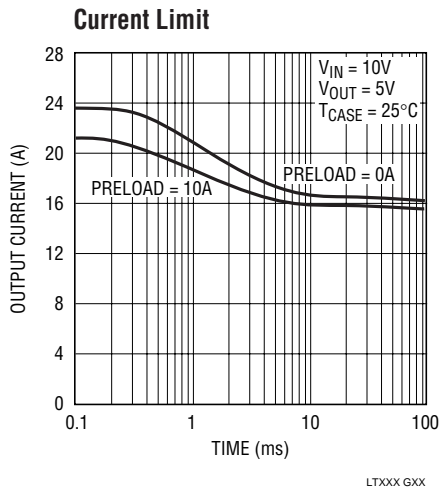
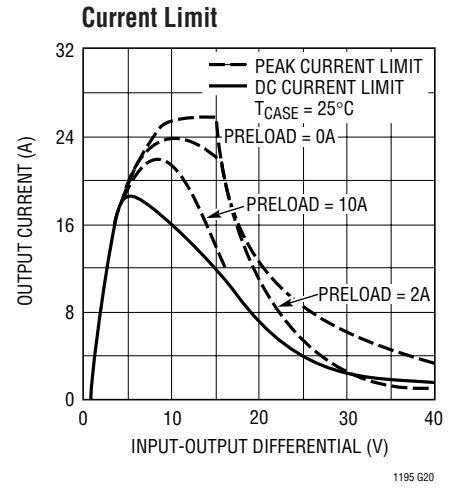
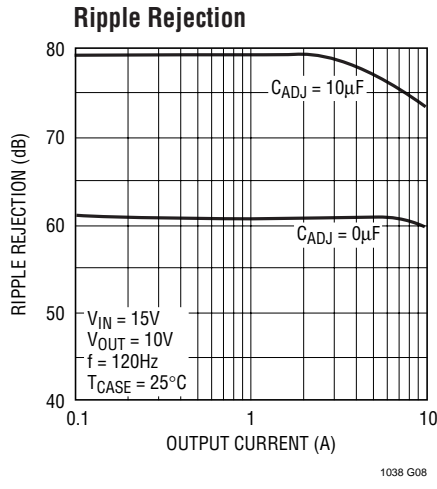
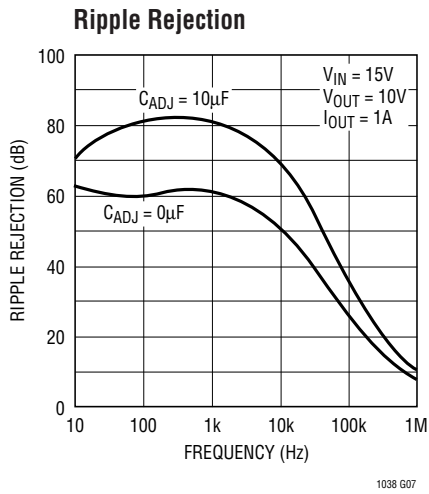

## APPLICATIONS INFORMATION

### General

The LT1038 develops a 1.25V reference voltage between the output and the adjustment terminal (see Figure 1). By placing a resistor, R1, between these two terminals, a constant current is caused to flow through R1 and down through R2 to set the overall output voltage. Normally this current is the specified minimum load current of 10mA or 20mA. Because  $I_{ADJ}$  is very small and constant when compared with the current through R1, it represents a small error and can usually be ignored.

### Bypass Capacitors

Input bypassing using a 1μF tantalum or 25μF electrolytic is recommended when the input filter capacitors are more than 5 inches from the device. Improved ripple rejection (80dB) can be accomplished by adding a 10μF capacitor from the ADJ pin to ground. Increasing the size of the capacitor to 20μF will help ripple rejection at low output voltage since the reactance of this capacitor should be small compared to the voltage setting resistor, R2. For improved AC transient response and to prevent the possibility of oscillation due to unknown reactive load, a 1μF capacitor is also recommended at the output. Because of their low impedance at high frequencies, the best type of capacitor to use is solid tantalum.

### Protection Diodes

The LT1038 does not require a protection diode from the adjustment terminal to the output (see Figure 2). Improved internal circuitry eliminates the need for this diode when the adjustment pin is bypassed with a capacitor to improve ripple rejection.

If a very large output capacitor is used, such as a 100μF shown in Figure 2, the regulator could be damaged or destroyed if the input is accidentally shorted to ground or crowbarred, due to the output capacitor discharging into the output terminal of the regulator. To prevent this, a diode, D1 as shown, is recommended to safely discharge the capacitor.

### Load Regulation

Because the LT1038 is a three-terminal device, it is not possible to provide true remote load sensing. Load regulation will be limited by the resistance of the wire connecting the regulator to the load. The data sheet specification for load regulation is measured at the bottom of the package. Negative side sensing can be a true Kelvin connection if the bottom of resistor R2 is returned to the negative side of the load. Although it may not be immediately obvious, best load regulation is obtained when the top of the resistor divider, R1, is connected *directly* to the case, *not to the load*. This is illustrated in Figure 3. If R1 were connected to the load, the effective resistance between the regulator and the load would be:

$$R_p \cdot \left( \frac{R_2 + R_1}{R_1} \right) \quad R_p = \text{Parasitic Line Resistance}$$

Connected as shown,  $R_p$  is not multiplied by the divider ratio.  $R_p$  is about 0.004Ω per foot using 16 gauge wire. This translates to 4mV/ft at 1A load current, so it is important to keep the lead between the regulator and the load as short as possible, and use large wire or PC board traces.

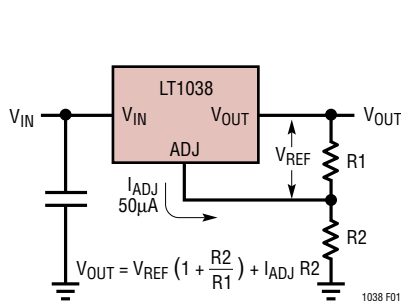

Figure 1. Basic Adjustable Regulator

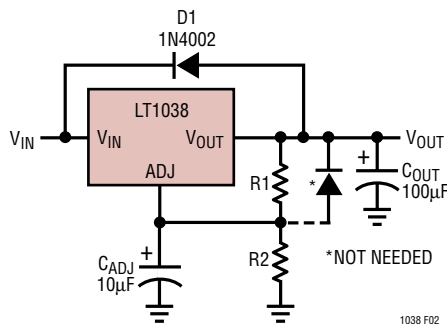

Figure 2

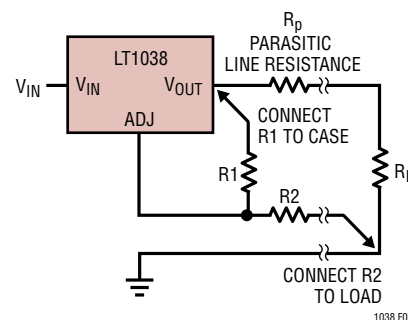
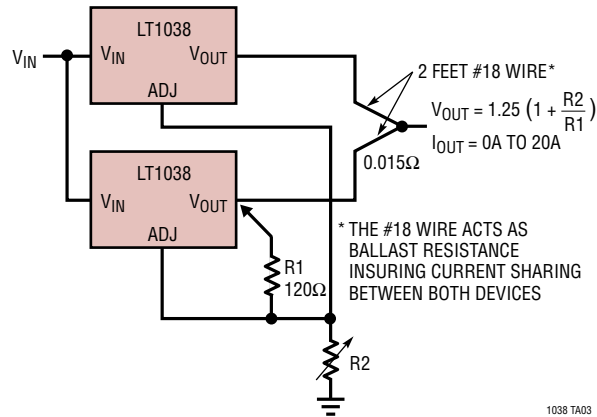

Figure 3. Connections for Best Load Regulation

## TYPICAL APPLICATIONS

### Paralleling Regulators



1038 TA03

### 10A Variable Regulator\*

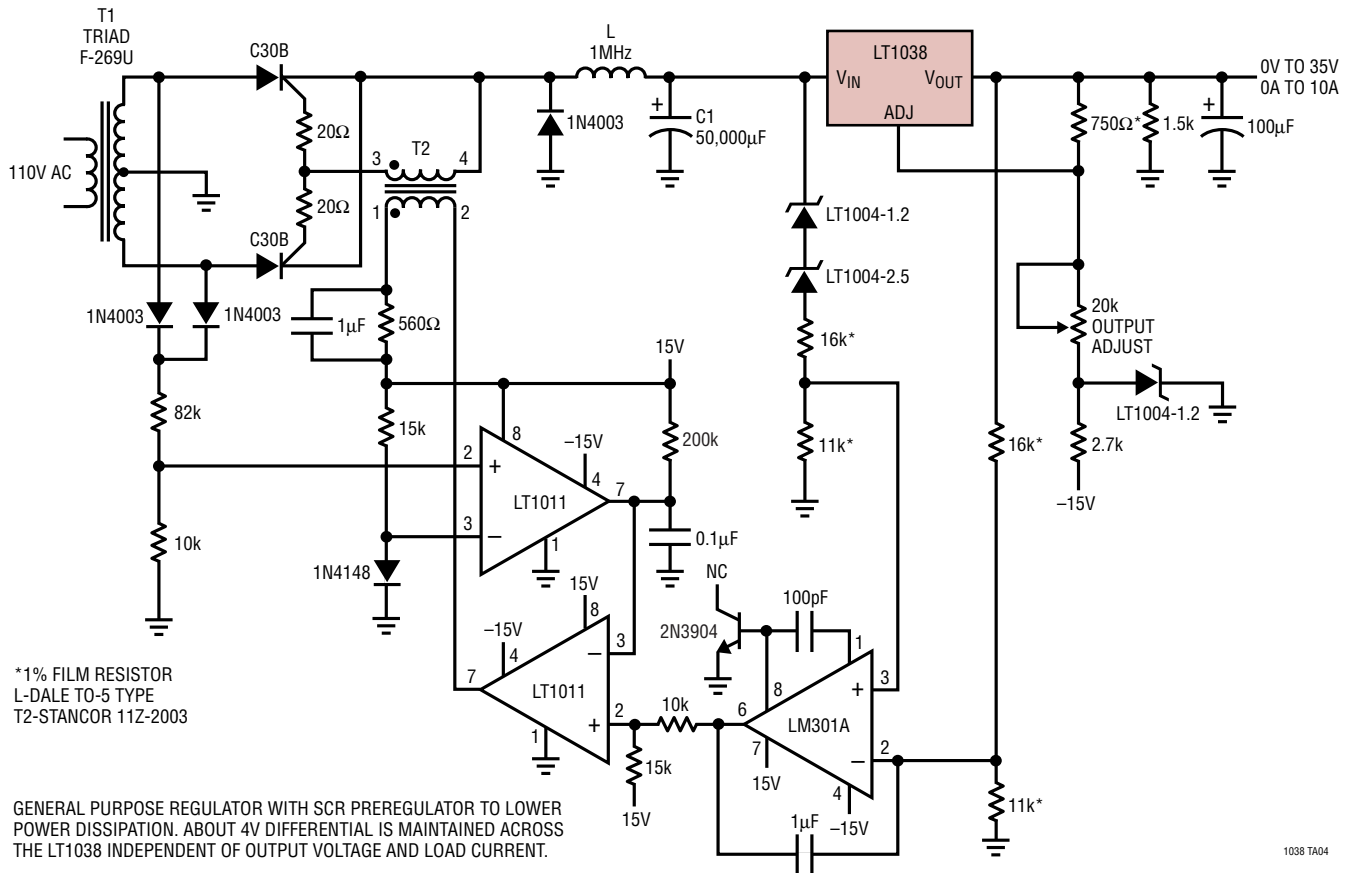

1038 TA04

# TYPICAL APPLICATIONS

Improving Ripple Rejection

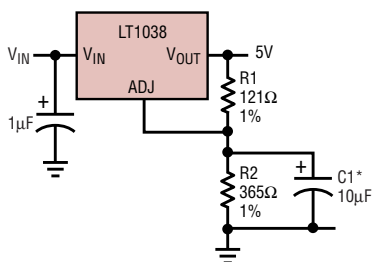

\*C1 IMPROVES RIPPLE REJECTION.  $X_C$  SHOULD BE SMALL COMPARED TO R2.

1038 TA05

1.2V to 25V Adjustable Regulator

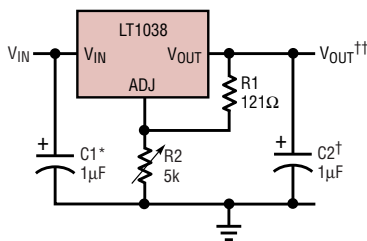

\*NEEDED IF DEVICE IS FAR FROM FILTER CAPACITORS  
†OPTIONAL—IMPROVES TRANSIENT RESPONSE

††  $V_{OUT} = 1.25V (1 + R2/R1)$

1038 TA06

5V Regulator with Shutdown

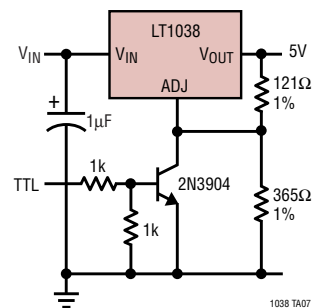

1038 TA07

Remote Sensing

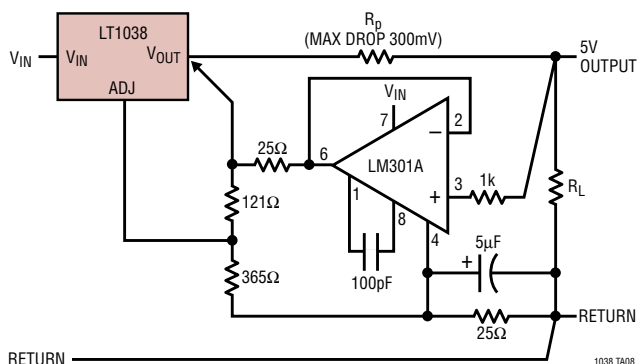

1038 TA08

Temperature Compensated Lead Acid Battery Charger

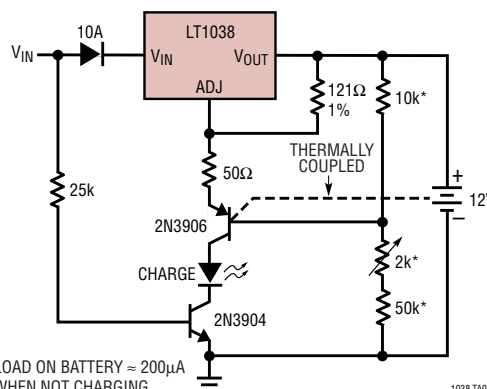

\*LOAD ON BATTERY = 200µA WHEN NOT CHARGING

1038 TA09

# SCHEMATIC DIAGRAM

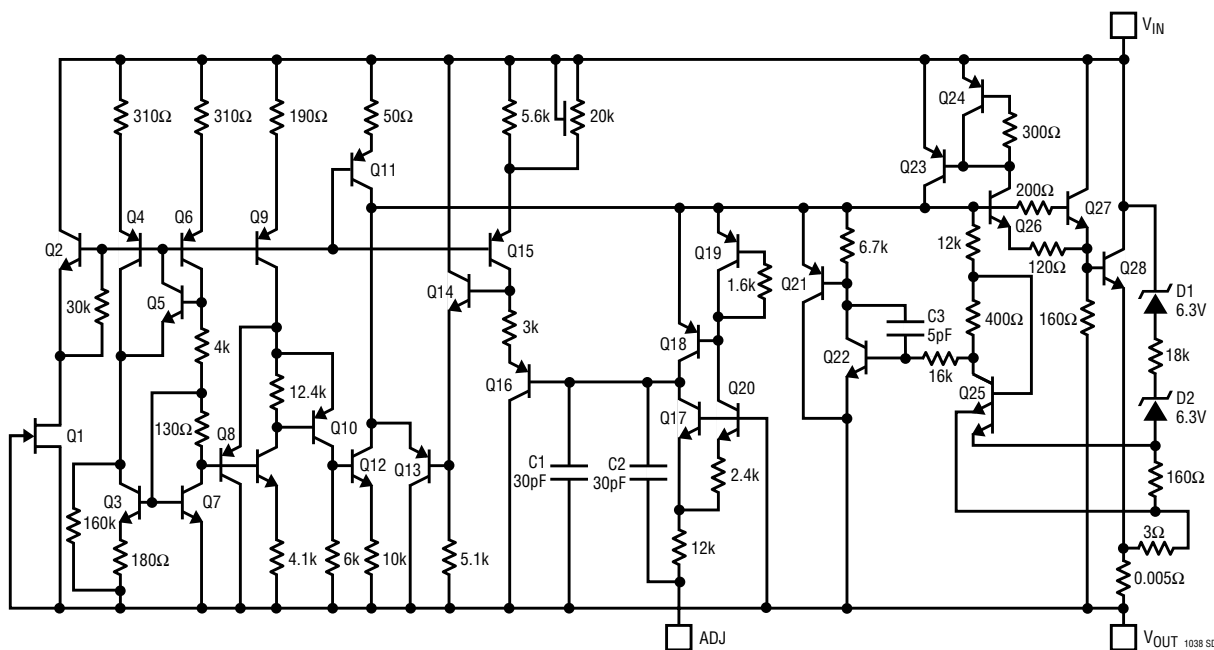

## TYPICAL APPLICATIONS

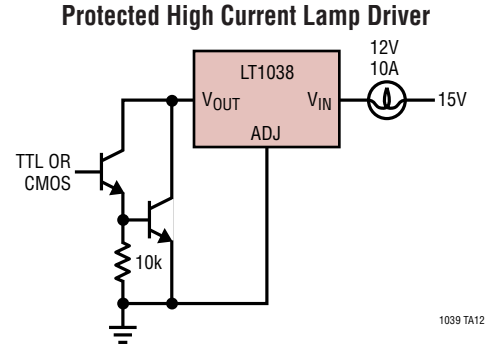
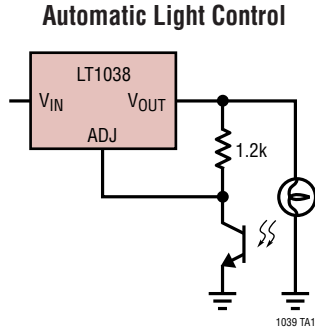
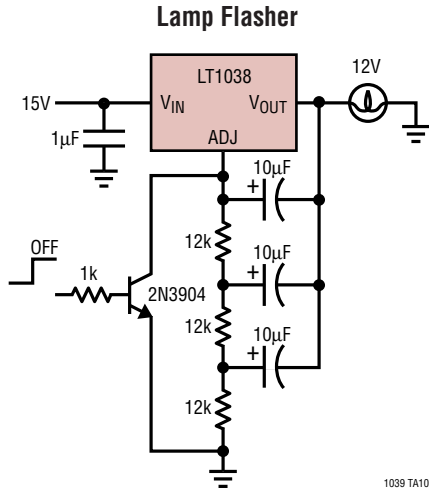

## PACKAGE DESCRIPTION Dimensions in inches (millimeters) unless otherwise noted.

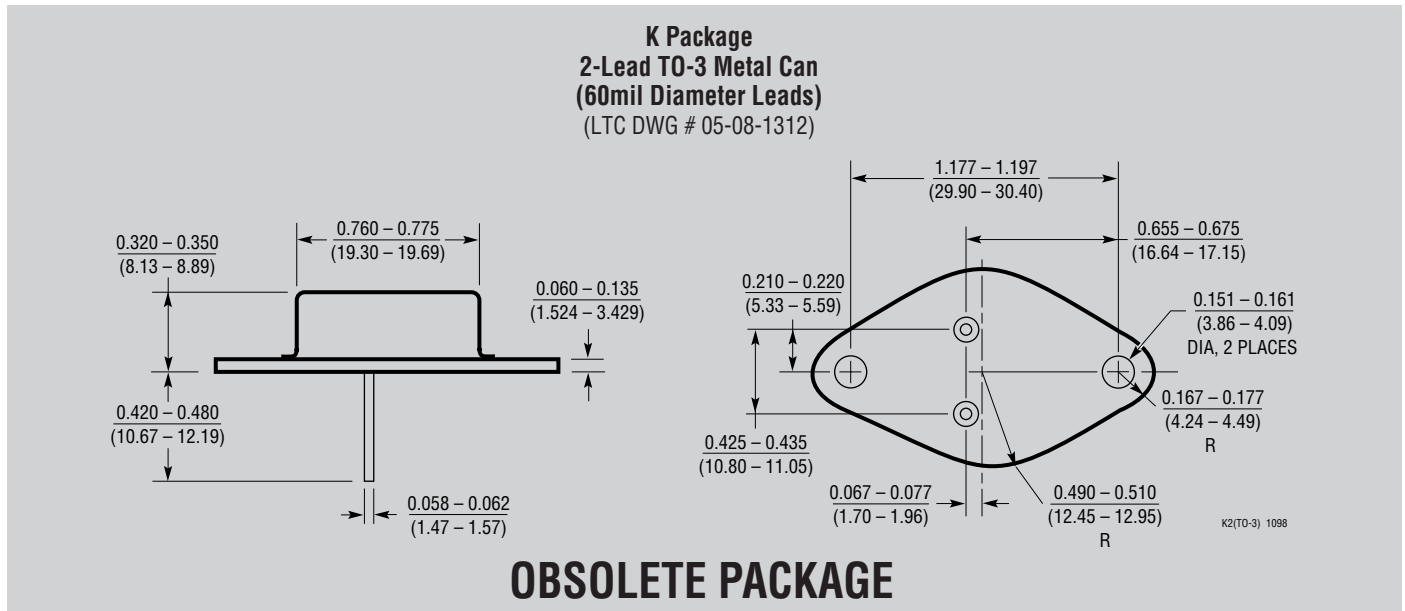

## RELATED PARTS

PART NUMBER	DESCRIPTION	COMMENTS
LT1084	Low Dropout, 0.01% Load Regulation	7.5A Max Current Output
LT1581	Low Dropout, 430mV at 10A	Best Replacement
LT1584	Low Dropout, 0.05% Load Regulation	7A Max Current Output
LT1585	Low Dropout, 0.05% Load Regulation	5A Max Current Output