

## FEATURES

- 1.5V to 12V Operating Supply Voltage Range
- 13V Absolute Maximum Rating
- 200 $\mu$ A Maximum No Load Supply Current at 5V
- Boost Pin (Pin 1) for Higher Switching Frequency
- 97% Minimum Open Circuit Voltage Conversion Efficiency
- 95% Minimum Power Conversion Efficiency
- $I_S = 1.5\mu$ A with 5V Supply When OSC Pin = 0V or  $V^+$
- High Voltage Upgrade to ICL7660/LTC1044

## APPLICATIONS

- Conversion of 10V to  $\pm 10$ V Supplies
- Conversion of 5V to  $\pm 5$ V Supplies
- Precise Voltage Division:  $V_{OUT} = V_{IN}/2 \pm 20$ ppm
- Voltage Multiplication:  $V_{OUT} = \pm nV_{IN}$
- Supply Splitter:  $V_{OUT} = \pm V_S/2$
- Automotive Applications
- Battery Systems with 9V Wall Adapters/Chargers

## DESCRIPTION

The LTC1044A is a monolithic CMOS switched-capacitor voltage converter. It plugs in for ICL7660/LTC1044 in applications where higher input voltage (up to 12V) is needed. The LTC1044A provides several conversion functions without using inductors. The input voltage can be inverted ( $V_{OUT} = -V_{IN}$ ), doubled ( $V_{OUT} = 2V_{IN}$ ), divided ( $V_{OUT} = V_{IN}/2$ ) or multiplied ( $V_{OUT} = \pm nV_{IN}$ ).

To optimize performance in specific applications, a boost function is available to raise the internal oscillator frequency by a factor of 7. Smaller external capacitors can be used in higher frequency operation to save board space. The internal oscillator can also be disabled to save power. The supply current drops to 1.5 $\mu$ A at 5V input when the OSC pin is tied to GND or  $V^+$ .

## TYPICAL APPLICATION

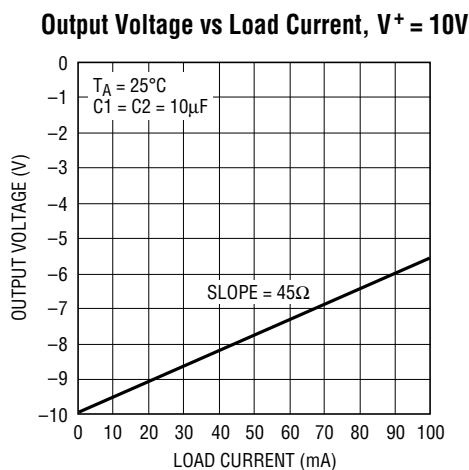
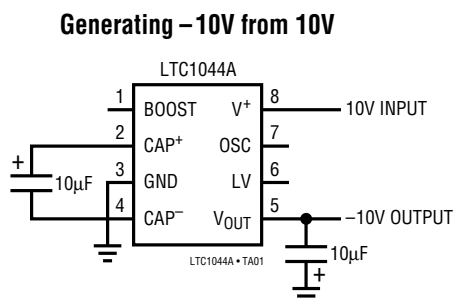

LTC1044A-TA02

## ABSOLUTE MAXIMUM RATINGS

(Note 1)

Supply Voltage .....	13V
Input Voltage on Pins 1, 6 and 7 (Note 2) .....	$-0.3V < V_{IN} < V^+ + 0.3V$
Current into Pin 6 .....	20 $\mu$ A
Output Short-Circuit Duration $V^+ \leq 6.5V$ .....	Continuous
Operating Temperature Range	
LTC1044AC .....	0°C to 70°C
LTC1044AI .....	-40°C to 85°C
Storage Temperature Range .....	-65°C to 150°C
Lead Temperature (Soldering, 10 sec) .....	300°C

## PACKAGE/ORDER INFORMATION

<p>N8 PACKAGE 8-LEAD PLASTIC DIP <math>T_{JMAX} = 110^{\circ}C, \theta_{JA} = 100^{\circ}C/W</math></p>	ORDER PART NUMBER
	LTC1044ACN8 LTC1044AIN8
<p>S8 PACKAGE 8-LEAD PLASTIC SOIC <math>T_{JMAX} = 110^{\circ}C, \theta_{JA} = 130^{\circ}C/W</math></p>	ORDER PART NUMBER
	LTC1044ACS8 LTC1044AIS8
	S8 PART MARKING
	1044A 1044AI

Consult factory for Military grade parts

## ELECTRICAL CHARACTERISTICS $V^+ = 5V, C_{OSC} = 0pF, T_A = 25^{\circ}C$ , See Test Circuit, unless otherwise noted.

SYMBOL	PARAMETER	CONDITIONS	LTC1044AC			LTC1044AI			UNITS
			MIN	TYP	MAX	MIN	TYP	MAX	
$I_S$	Supply Current	$R_L = \infty$ , Pins 1 and 7, No Connection		60	200		60	200	$\mu$ A
		$R_L = \infty$ , Pins 1 and 7, No Connection, $V^+ = 3V$		15			15		$\mu$ A
	Minimum Supply Voltage	$R_L = 10k$	●	1.5		1.5		V	
	Maximum Supply Voltage	$R_L = 10k$	●		12		12	V	
$R_{OUT}$	Output Resistance	$I_L = 20mA, f_{OSC} = 5kHz$			100		100	$\Omega$	
			●		120		130	$\Omega$	
		$V^+ = 2V, I_L = 3mA, f_{OSC} = 1kHz$	●		310		325	$\Omega$	
$f_{OSC}$	Oscillator Frequency	$V^+ = 5V$ , (Note 3)	●	5		5		kHz	
		$V^+ = 2V$	●	1		1		kHz	
$P_{EFF}$	Power Efficiency	$R_L = 5k, f_{OSC} = 5kHz$		95	98		95	98	%
	Voltage Conversion Efficiency	$R_L = \infty$		97	99.9		97	99.9	%
	Oscillator Sink or Source Current	$V_{OSC} = 0V$ or $V^+$ Pin 1 (BOOST) = $0V$ Pin 1 (BOOST) = $V^+$	●		3		3	$\mu$ A	
			●		20		20	$\mu$ A	

The ● denotes specifications which apply over the full operating temperature range; all other limits and typicals  $T_A = 25^{\circ}C$ .

**Note 1:** Absolute maximum ratings are those values beyond which the life of a device may be impaired.

**Note 2:** Connecting any input terminal to voltages greater than  $V^+$  or less than ground may cause destructive latch-up. It is recommended that no

inputs from sources operating from external supplies be applied prior to power-up of the LTC1044A.

**Note 3:**  $f_{OSC}$  is tested with  $C_{OSC} = 100pF$  to minimize the effects of test fixture capacitance loading. The  $0pF$  frequency is correlated to this  $100pF$  test point, and is intended to simulate the capacitance at pin 7 when the device is plugged into a test socket and no external capacitor is used.

# TYPICAL PERFORMANCE CHARACTERISTICS Using the Test Circuit

**Operating Voltage Range vs Temperature**

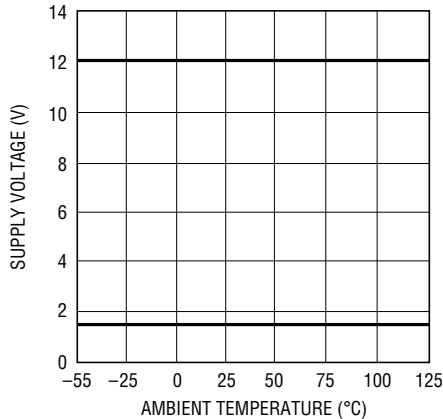

LTC1044A • TPC01

**Power Efficiency vs Oscillator Frequency, V+ = 5V**

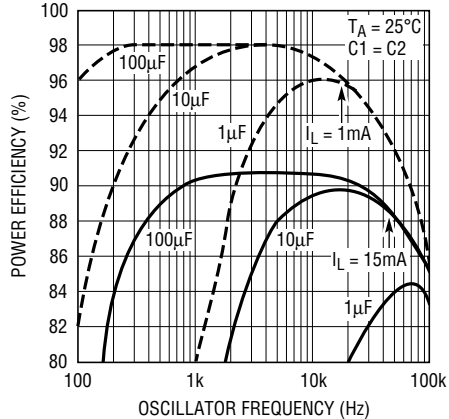

LTC1044A • G02

**Power Efficiency vs Oscillator Frequency, V+ = 10V**

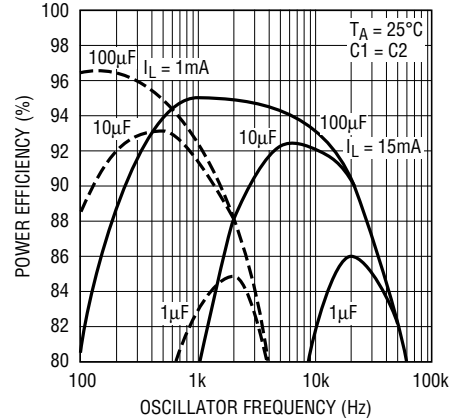

LTC1044A • TPC03

**Output Resistance vs Oscillator Frequency, V+ = 5V**

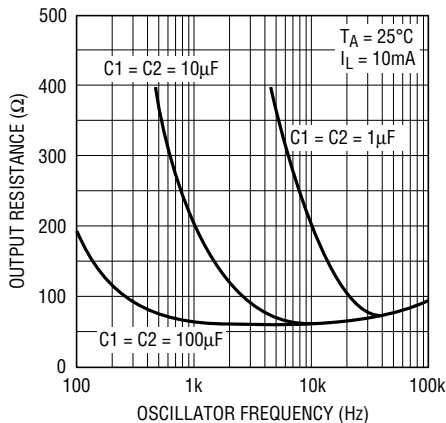

LTC1044A • TPC04

**Output Resistance vs Oscillator Frequency, V+ = 10V**

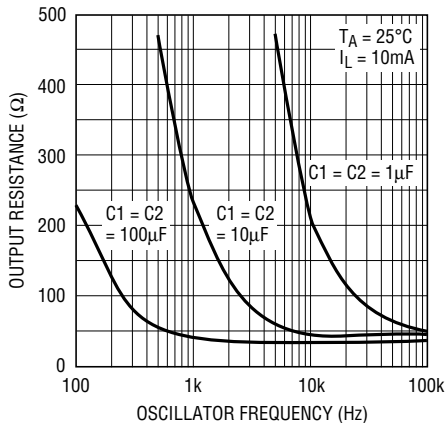

LTC1044A • TPC05

**Power Conversion Efficiency vs Load Current, V+ = 2V**

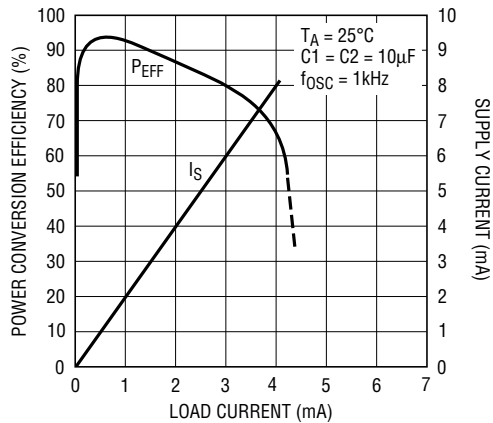

LTC1044A • TPC06

**Power Conversion Efficiency vs Load Current, V+ = 5V**

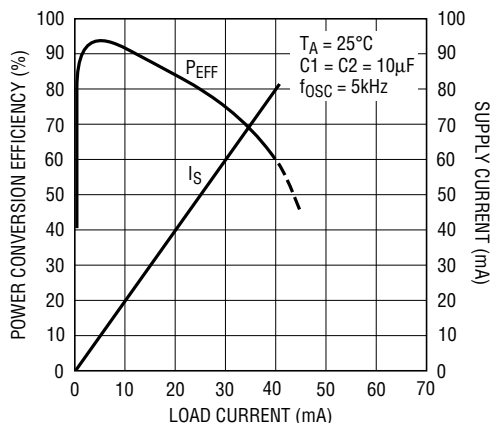

LTC1044A • TPC07

**Power Conversion Efficiency vs Load Current, V+ = 10V**

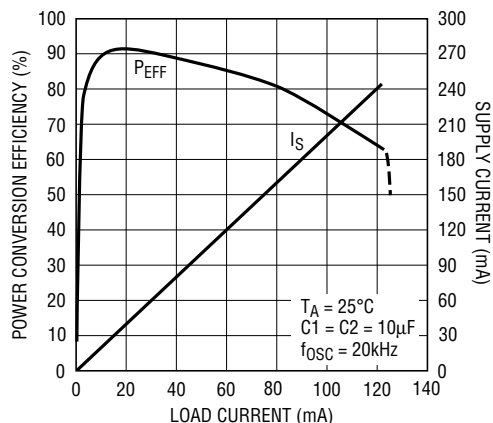

LTC1044A • TPC08

## TYPICAL PERFORMANCE CHARACTERISTICS Using the Test Circuit

**Output Resistance vs Supply Voltage**

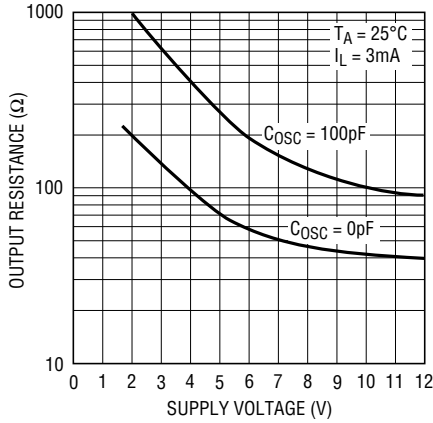

**Output Voltage vs Load Current,  $V^+ = 2\text{V}$**

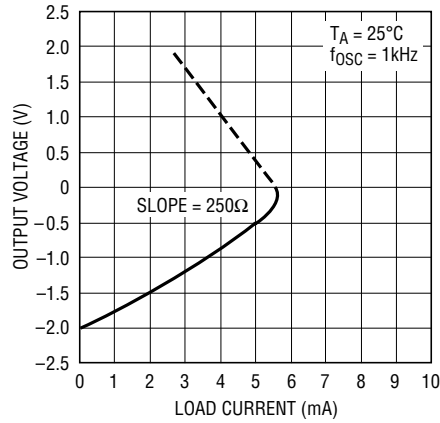

**Output Voltage vs Load Current,  $V^+ = 5\text{V}$**

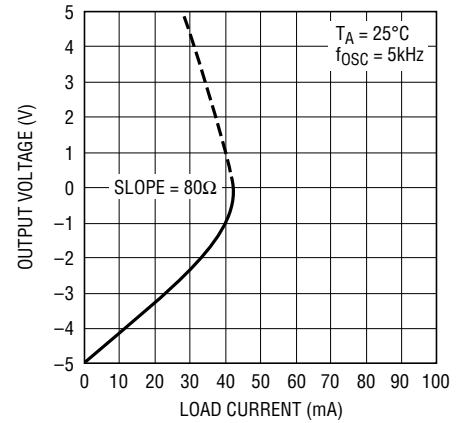

**Output Voltage vs Load Current,  $V^+ = 10\text{V}$**

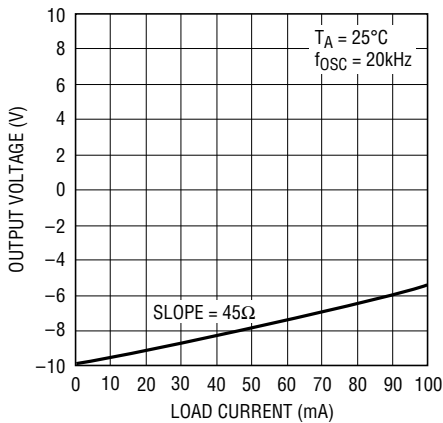

**Output Resistance vs Temperature**

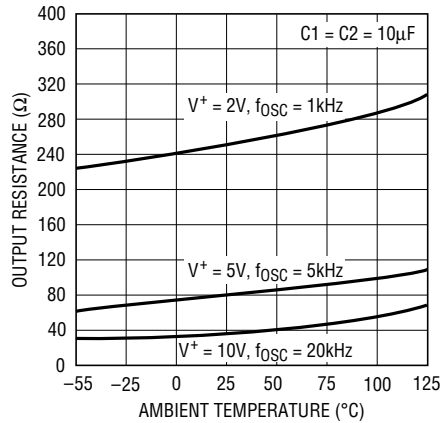

**Oscillator Frequency as a Function of  $C_{OSC}$ ,  $V^+ = 5\text{V}$**

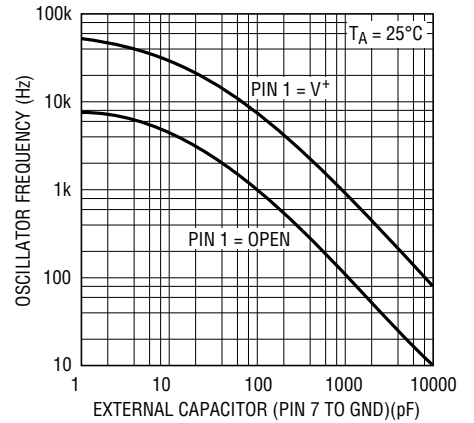

**Oscillator Frequency as a Function of  $C_{OSC}$ ,  $V^+ = 10\text{V}$**

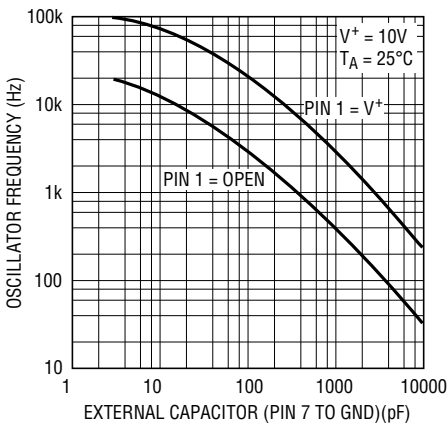

**Oscillator Frequency vs Supply Voltage**

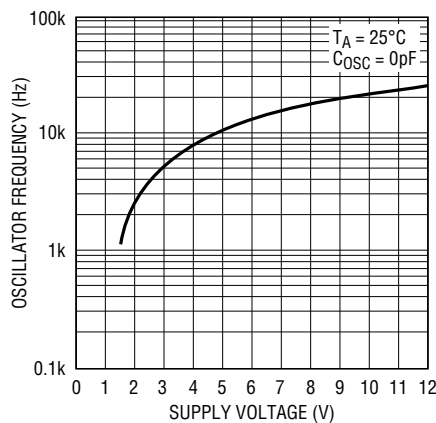

**Oscillator Frequency vs Temperature**

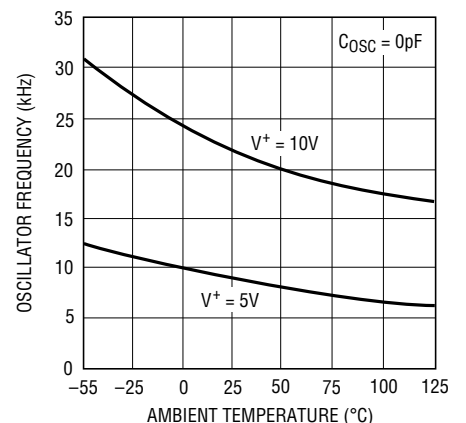

## TEST CIRCUIT

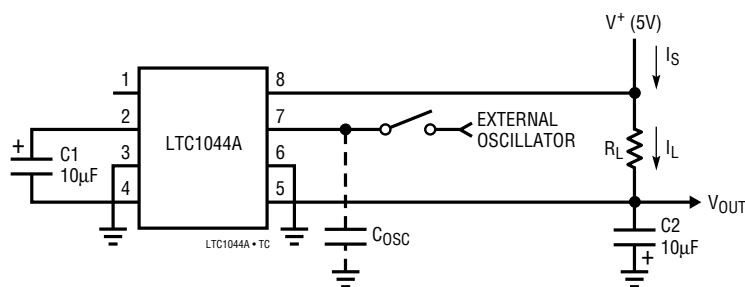

## APPLICATIONS INFORMATION

### Theory of Operation

To understand the theory of operation of the LTC1044A, a review of a basic switched-capacitor building block is helpful.

In Figure 1, when the switch is in the left position, capacitor C1 will charge to voltage V1. The total charge on C1 will be  $q_1 = C_1V_1$ . The switch then moves to the right, discharging C1 to voltage V2. After this discharge time, the charge on C1 is  $q_2 = C_1V_2$ . Note that charge has been transferred from the source, V1, to the output, V2. The amount of charge transferred is:

$$\Delta q = q_1 - q_2 = C_1(V_1 - V_2)$$

If the switch is cycled  $f$  times per second, the charge transfer per unit time (i.e., current) is:

$$I = f \times \Delta q = f \times C_1(V_1 - V_2)$$

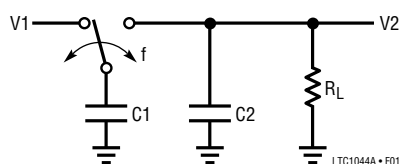

Figure 1. Switched-Capacitor Building Block

Rewriting in terms of voltage and impedance equivalence,

$$I = \frac{V_1 - V_2}{1/(f \times C_1)} = \frac{V_1 - V_2}{R_{EQUIV}}$$

A new variable,  $R_{EQUIV}$ , has been defined such that  $R_{EQUIV} = 1/(f \times C_1)$ . Thus, the equivalent circuit for the switched-capacitor network is as shown in Figure 2.

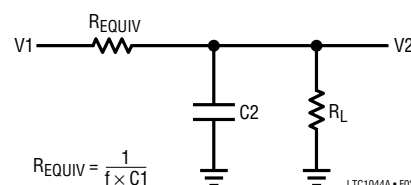

Figure 2. Switched-Capacitor Equivalent Circuit

Examination of Figure 3 shows that the LTC1044A has the same switching action as the basic switched-capacitor building block. With the addition of finite switch-on resistance and output voltage ripple, the simple theory although not exact, provides an intuitive feel for how the device works.

For example, if you examine power conversion efficiency as a function of frequency (see typical curve), this simple theory will explain how the LTC1044A behaves. The loss, and hence the efficiency, is set by the output impedance. As frequency is decreased, the output impedance will eventually be dominated by the  $1/(f \times C_1)$  term, and power efficiency will drop. The typical curves for Power Efficiency vs Frequency show this effect for various capacitor values.

Note also that power efficiency decreases as frequency goes up. This is caused by internal switching losses which occur due to some finite charge being lost on each switching cycle. This charge loss per unit cycle, when multiplied by the switching frequency, becomes a current loss. At high frequency this loss becomes significant and the power efficiency starts to decrease.

**APPLICATIONS INFORMATION**

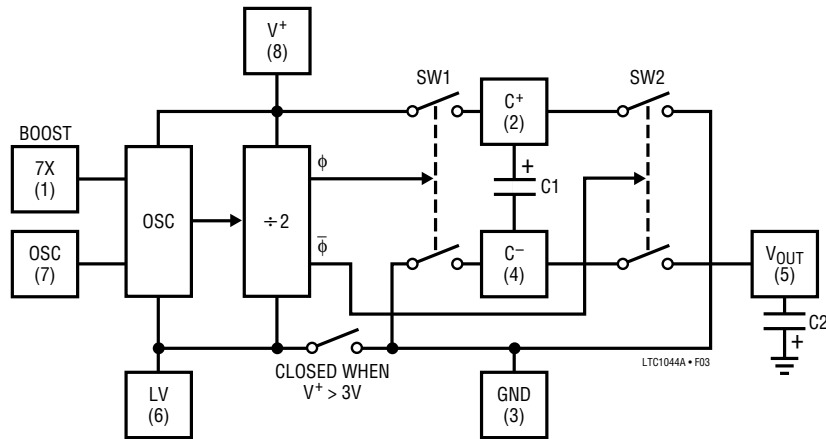

**Figure 3. LTC1044A Switched-Capacitor Voltage Converter Block Diagram**

**LV (Pin 6)**

The internal logic of the LTC1044A runs between  $V^+$  and LV (pin 6). For  $V^+$  greater than or equal to 3V, an internal switch shorts LV to GND (pin 3). For  $V^+$  less than 3V, the LV pin should be tied to GND. For  $V^+$  greater than or equal to 3V, the LV pin can be tied to GND or left floating.

**OSC (Pin 7) and Boost (Pin 1)**

The switching frequency can be raised, lowered, or driven from an external source. Figure 4 shows a functional diagram of the oscillator circuit.

By connecting the boost pin (pin 1) to  $V^+$ , the charge and discharge current is increased and hence, the frequency is increased by approximately 7 times. Increasing the

frequency will decrease output impedance and ripple for higher load currents.

Loading pin 7 with more capacitance will lower the frequency. Using the boost (pin 1) in conjunction with external capacitance on pin 7 allows user selection of the frequency over a wide range.

Driving the LTC1044A from an external frequency source can be easily achieved by driving pin 7 and leaving the boost pin open as shown in Figure 5. The output current from pin 7 is small (typically 0.5 $\mu$ A) so a logic gate is capable of driving this current. The choice of using a CMOS logic gate is best because it can operate over a wide supply voltage range (3V to 15V) and has enough voltage swing to drive the internal Schmitt trigger shown in Figure 4. For 5V applications, a TTL logic gate can be used by simply adding an external pull-up resistor (see Figure 5).

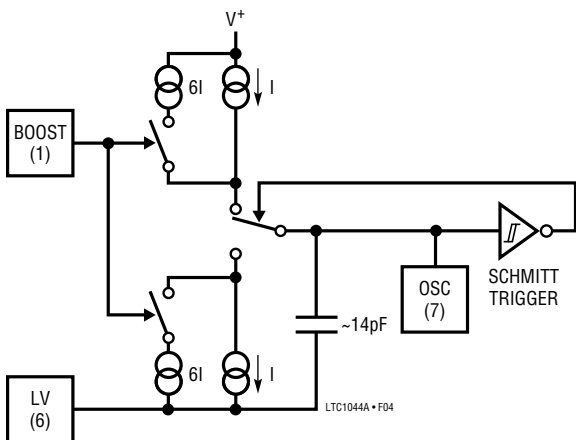

**Figure 4. Oscillator**

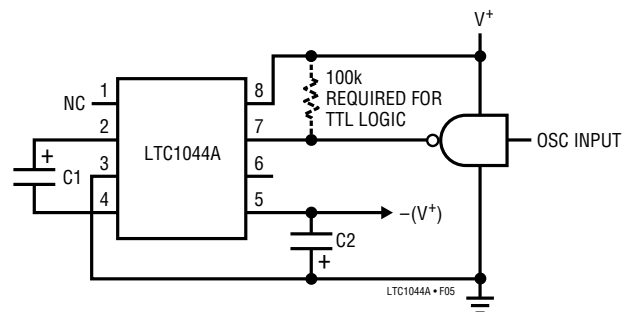

**Figure 5. External Clocking**

## APPLICATIONS INFORMATION

### Capacitor Selection

External capacitors C1 and C2 are not critical. Matching is not required, nor do they have to be high quality or tight tolerance. Aluminum or tantalum electrolytics are excellent choices with cost and size being the only consideration.

### Negative Voltage Converter

Figure 6 shows a typical connection which will provide a negative supply from an available positive supply. This circuit operates over full temperature and power supply ranges *without* the need of any external diodes. The LV pin (pin 6) is shown grounded, but for  $V^+ \geq 3V$  it may be “floated”, since LV is internally switched to ground (pin 3) for  $V^+ \geq 3V$ .

The output voltage (pin 5) characteristics of the circuit are those of a nearly ideal voltage source in series with an  $80\Omega$  resistor. The  $80\Omega$  output impedance is composed of two terms:

1. The equivalent switched-capacitor resistance (see Theory of Operation).
2. A term related to the on-resistance of the MOS switches.

At an oscillator frequency of 10kHz and  $C1 = 10\mu F$ , the first term is:

$$R_{EQUIV} = \frac{1}{(f_{OSC}/2) \times C1}$$

$$= \frac{1}{5 \times 10^3 \times 10 \times 10^{-6}} = 20\Omega$$

Notice that the above equation for  $R_{EQUIV}$  is *not* a capacitive reactance equation ( $X_C = 1/\omega C$ ) and does not contain a  $2\pi$  term.

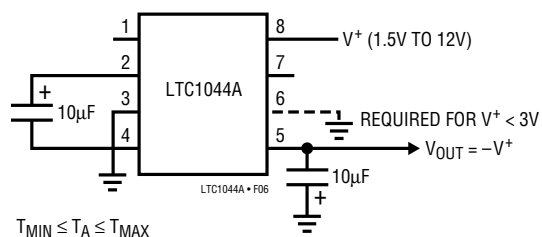

Figure 6. Negative Voltage Converter

The exact expression for output resistance is extremely complex, but the dominant effect of the capacitor is clearly shown on the typical curves of Output Resistance and Power Efficiency vs Frequency. For  $C1 = C2 = 10\mu F$ , the output impedance goes from  $60\Omega$  at  $f_{OSC} = 10kHz$  to  $200\Omega$  at  $f_{OSC} = 1kHz$ . As the  $1/(f \times C)$  term becomes large compared to the switch-on resistance term, the output resistance is determined by  $1/(f \times C)$  only.

### Voltage Doubling

Figure 7 shows a two-diode capacitive voltage doubler. With a 5V input, the output is 9.93V with no load and 9.13V with a 10mA load. With a 10V input, the output is 19.93V with no load and 19.28V with a 10mA load.

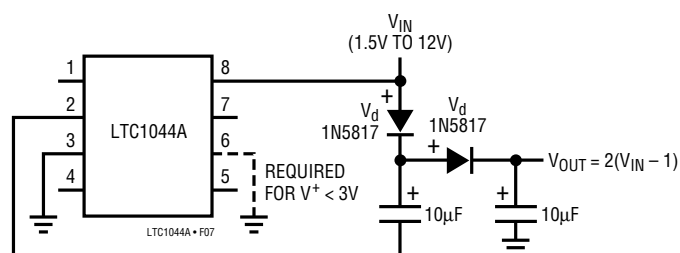

Figure 7. Voltage Doubler

### Ultra-Precision Voltage Divider

An ultra-precision voltage divider is shown in Figure 8. To achieve the 0.0002% accuracy indicated, the load current should be kept below 100nA. However, with a slight loss in accuracy the load current can be increased.

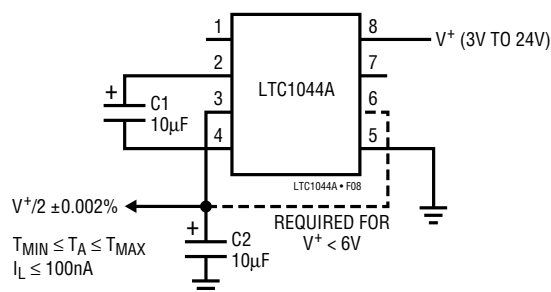

Figure 8. Ultra-Precision Voltage Divider

## APPLICATIONS INFORMATION

### Battery Splitter

A common need in many systems is to obtain (+) and (-) supplies from a single battery or single power supply system. Where current requirements are small, the circuit shown in Figure 9 is a simple solution. It provides symmetrical  $\pm$  output voltages, both equal to one half input voltage. The output voltages are both referenced to pin 3

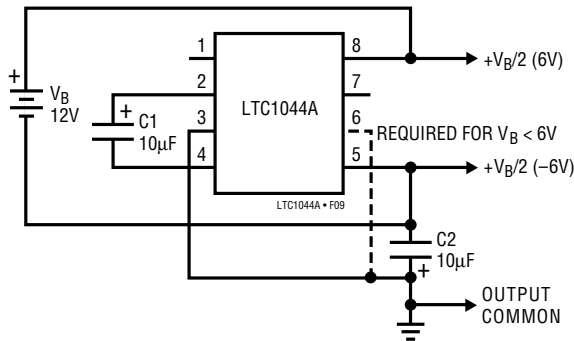

Figure 9. Battery Splitter

(output common). If the input voltage between pin 8 and pin 5 is less than 6V, pin 6 should also be connected to pin 3 as shown by the dashed line.

### Paralleling for Lower Output Resistance

Additional flexibility of the LTC1044A is shown in Figures 10 and 11.

Figure 10 shows two LTC1044As connected in parallel to provide a lower effective output resistance. If, however, the output resistance is dominated by  $1/(f \times C1)$ , increasing the capacitor size (C1) or increasing the frequency will be of more benefit than the paralleling circuit shown.

Figure 11 makes use of “stacking” two LTC1044As to provide even higher voltages. A negative voltage doubler or tripler can be achieved, depending upon how pin 8 of the second LTC1044A is connected, as shown schematically by the switch. The available output current will be dictated/ decreased by the product of the individual power conversion efficiencies and the voltage step-up ratio.

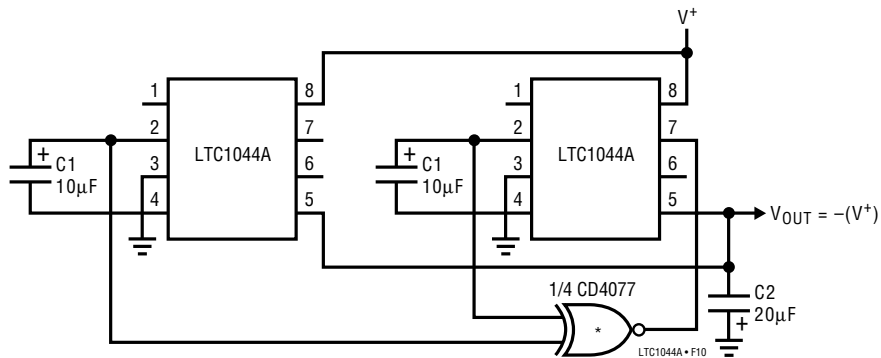

\*THE EXCLUSIVE NOR GATE SYNCHRONIZES BOTH LTC1044As TO MINIMIZE RIPPLE

Figure 10. Paralleling for Lower Output Resistance

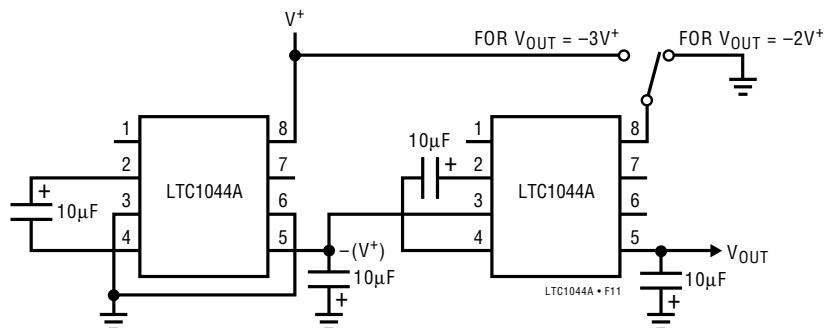
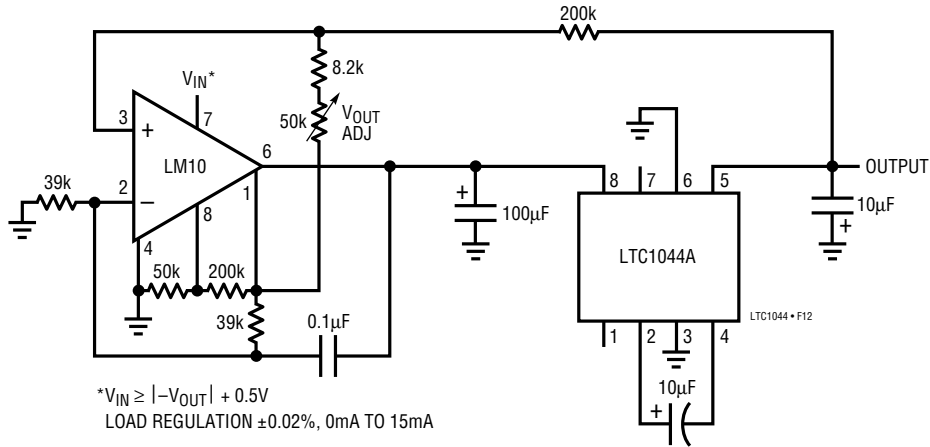

Figure 11. Stacking for Higher Voltage

# TYPICAL APPLICATIONS

## Low Output Impedance Voltage Converter



## Single 5V Strain Gauge Bridge Signal Conditioner

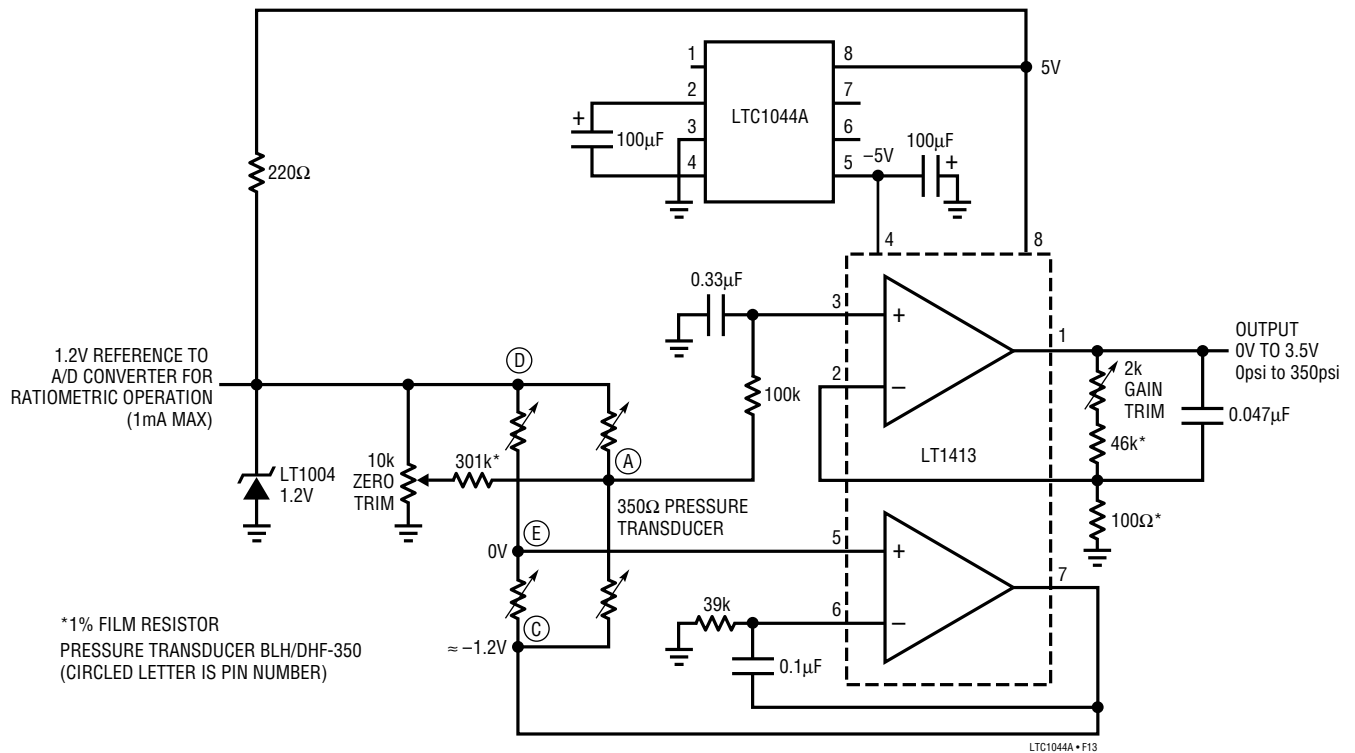

**TYPICAL APPLICATIONS**

**Regulated Output 3V to 5V Converter**

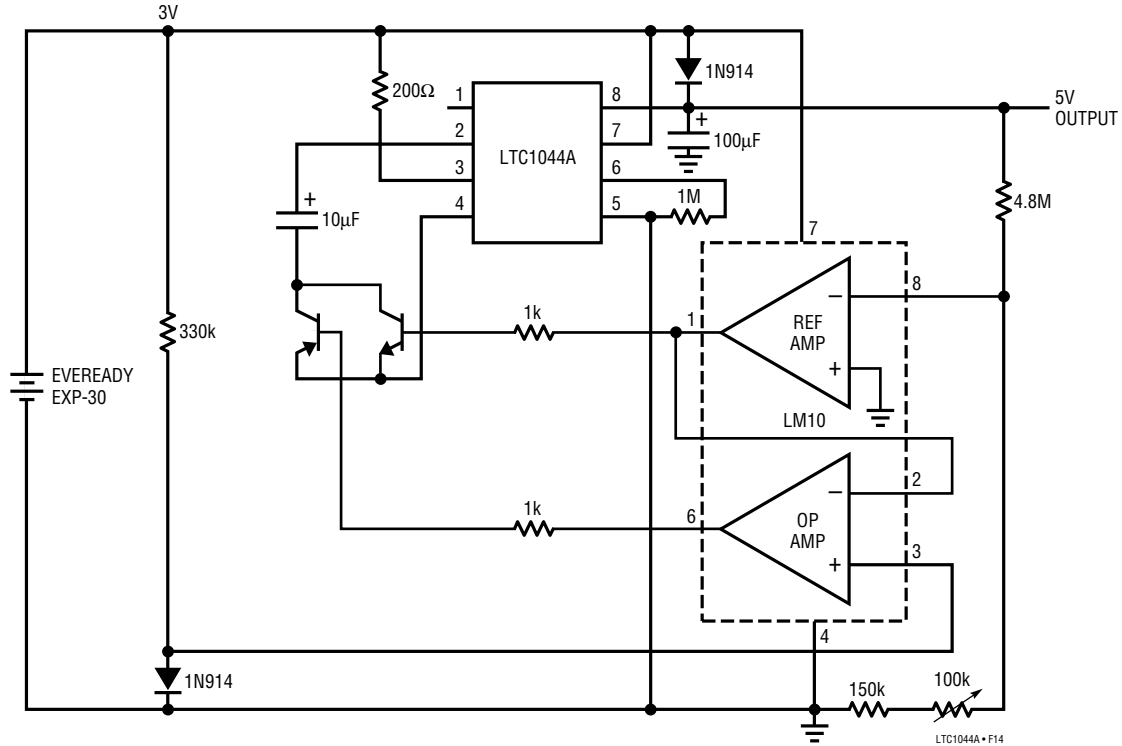

**Low Dropout 5V Regulator**

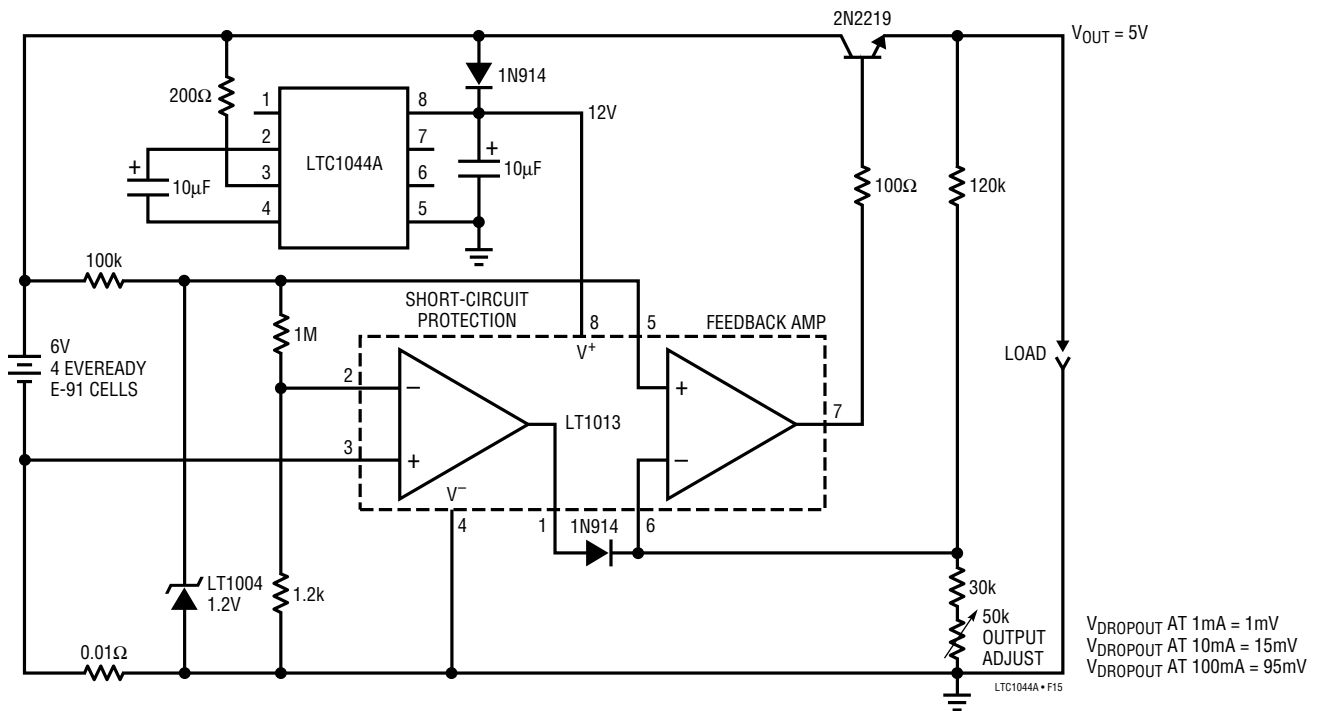

**PACKAGE DESCRIPTION** Dimensions in inches (millimeters) unless otherwise noted.

**N8 Package  
8-Lead Plastic DIP**

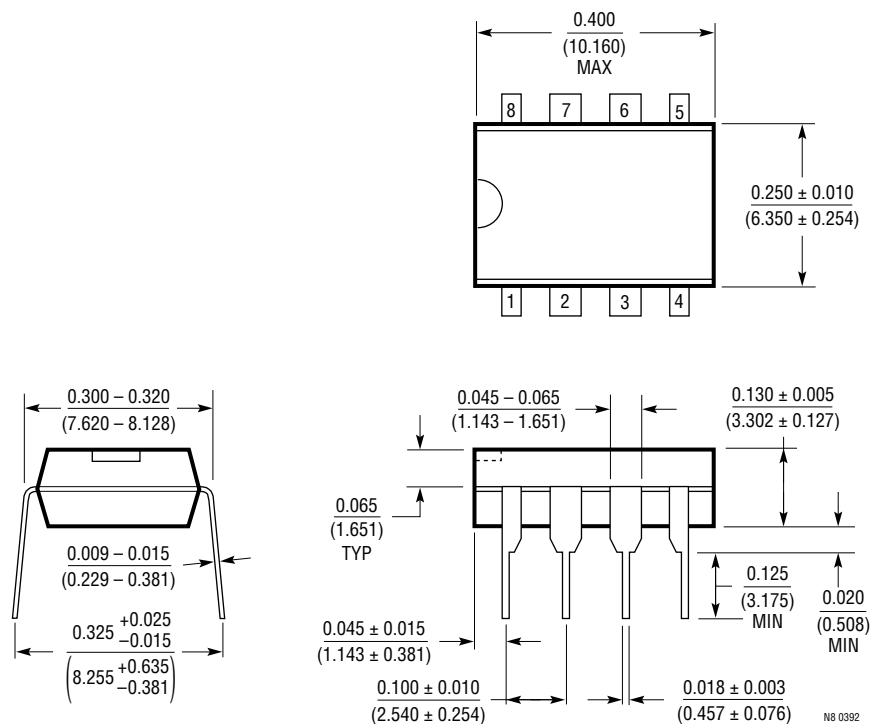

**S8 Package  
8-Lead Plastic SOIC**

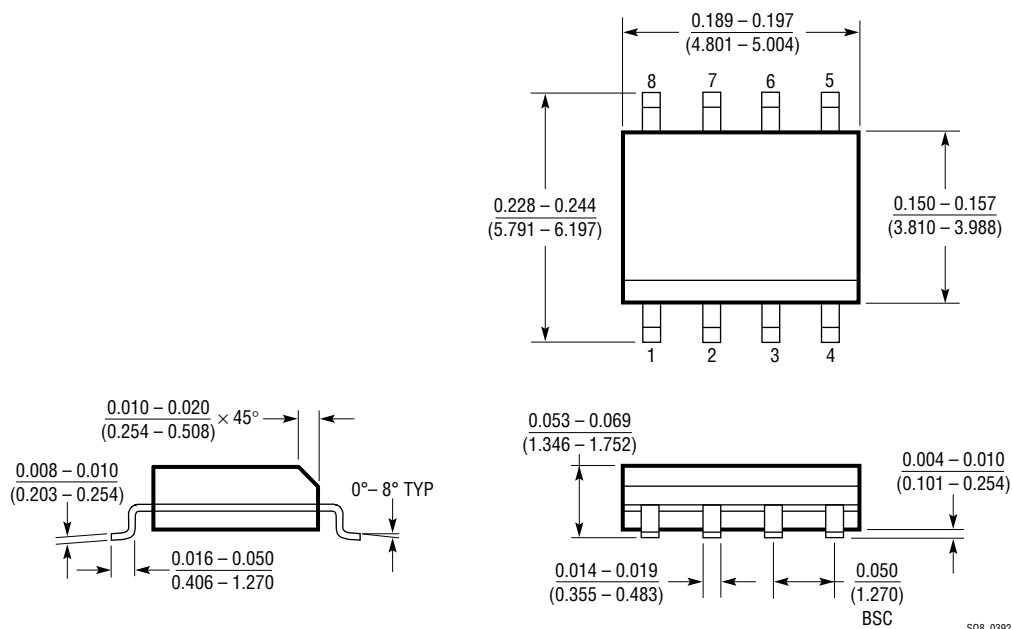

**U.S. Area Sales Offices****NORTHEAST REGION**

**Linear Technology Corporation**  
 One Oxford Valley  
 2300 E. Lincoln Hwy., Suite 306  
 Langhorne, PA 19047  
 Phone: (215) 757-8578  
 FAX: (215) 757-5631

**Linear Technology Corporation**

266 Lowell St., Suite B-8  
 Wilmington, MA 01887  
 Phone: (508) 658-3881  
 FAX: (508) 658-2701

**SOUTHEAST REGION**

**Linear Technology Corporation**  
 17060 Dallas Parkway  
 Suite 208  
 Dallas, TX 75248  
 Phone: (214) 733-3071  
 FAX: (214) 380-5138

**CENTRAL REGION**

**Linear Technology Corporation**  
 Chesapeake Square  
 229 Mitchell Court, Suite A-25  
 Addison, IL 60101  
 Phone: (708) 620-6910  
 FAX: (708) 620-6977

**SOUTHWEST REGION**

**Linear Technology Corporation**  
 22141 Ventura Blvd.  
 Suite 206  
 Woodland Hills, CA 91364  
 Phone: (818) 703-0835  
 FAX: (818) 703-0517

**NORTHWEST REGION**

**Linear Technology Corporation**  
 782 Sycamore Dr.  
 Milpitas, CA 95035  
 Phone: (408) 428-2050  
 FAX: (408) 432-6331

**International Sales Offices****FRANCE**

**Linear Technology S.A.R.L.**  
 Immeuble "Le Quartz"  
 58 Chemin de la Justice  
 92290 Chatenay Malabry  
 France  
 Phone: 33-1-41079555  
 FAX: 33-1-46314613

**GERMANY**

**Linear Technology GMBH**  
 Untere Hauptstr. 9  
 D-85386 Eching  
 Germany  
 Phone: 49-89-3197410  
 FAX: 49-89-3194821

**JAPAN**

**Linear Technology KK**  
 5F YZ Bldg.  
 4-4-12 Iidabashi, Chiyoda-Ku  
 Tokyo, 102 Japan  
 Phone: 81-3-3237-7891  
 FAX: 81-3-3237-8010

**KOREA**

**Linear Technology Korea Branch**  
 Namsong Building, #505  
 Itaewon-Dong 260-199  
 Yongsan-Ku, Seoul  
 Korea  
 Phone: 82-2-792-1617  
 FAX: 82-2-792-1619

**SINGAPORE**

**Linear Technology Pte. Ltd.**  
 101 Boon Keng Road  
 #02-15 Kallang Ind. Estates  
 Singapore 1233  
 Phone: 65-293-5322  
 FAX: 65-292-0398

**TAIWAN**

**Linear Technology Corporation**  
 Rm. 801, No. 46, Sec. 2  
 Chung Shan N. Rd.  
 Taipei, Taiwan, R.O.C.  
 Phone: 886-2-521-7575  
 FAX: 886-2-562-2285

**UNITED KINGDOM**

**Linear Technology (UK) Ltd.**  
 The Coliseum, Riverside Way  
 Camberley, Surrey GU15 3YL  
 United Kingdom  
 Phone: 44-276-677676  
 FAX: 44-276-64851

**World Headquarters**

**Linear Technology Corporation**  
 1630 McCarthy Blvd.  
 Milpitas, CA 95035-7487  
 Phone: (408) 432-1900  
 FAX: (408) 434-0507

08/16/93