

“Inductorless” 5V to -5V Converter

FEATURES

- 50mA Output Current
- Plug-In Compatible with ICL7660/LTC1044
- $R_{OUT} = 35\Omega$ Maximum
- 300 μ A Maximum No Load Supply Current at 5V
- Boost Pin (Pin 1) for Higher Switching Frequency
- 97% Minimum Open-Circuit Voltage Conversion Efficiency
- 95% Minimum Power Conversion Efficiency
- Wide Operating Supply Voltage Range: 1.5V to 6V
- Easy to Use
- Low Cost

APPLICATIONS

- Conversion of 5V to ± 5 V Supplies
- Precise Voltage Division, $V_{OUT} = V_{IN}/2$
- Supply Splitter, $V_{OUT} = \pm V_S/2$

DESCRIPTION

The LTC[®]1046 is a 50mA monolithic CMOS switched capacitor voltage converter. It plugs in for the ICL7660/LTC1044 in 5V applications where more output current is needed. The device is optimized to provide high current capability for input voltages of 6V or less. It trades off operating voltage to get higher output current. The LTC1046 provides several voltage conversion functions: the input voltage can be inverted ($V_{OUT} = -V_{IN}$), divided ($V_{OUT} = V_{IN}/2$) or multiplied ($V_{OUT} = \pm nV_{IN}$).

Designed to be pin-for-pin and functionally compatible with the ICL7660 and LTC1044, the LTC1046 provides 2.5 times the output drive capability.

 LTC and LT are registered trademarks of Linear Technology Corporation.

TYPICAL APPLICATION

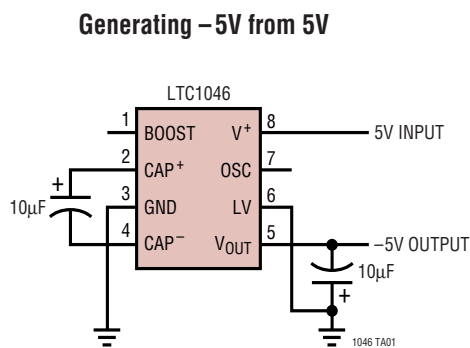

Output Voltage vs Load Current for $V^+ = 5$ V

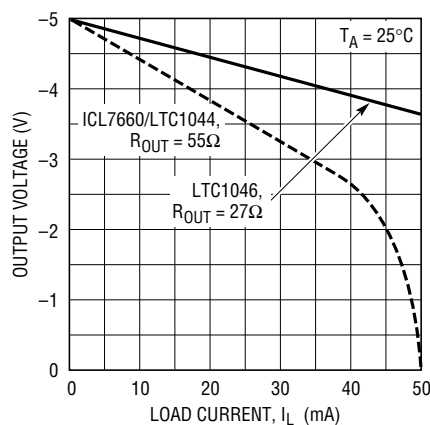

ABSOLUTE MAXIMUM RATINGS (Note 1)

Supply Voltage	6.5V	Operating Temperature Range	
Input Voltage on Pins 1, 6 and 7 (Note 2)	$-0.3 < V_{IN} < (V^+) + 0.3V$	LTC1046C	$0^{\circ}C \leq T_A \leq 70^{\circ}C$
Current into Pin 6	20 μ A	LTC1046I	$-40^{\circ}C \leq T_A \leq 85^{\circ}C$
Output Short Circuit Duration ($V^+ \leq 6V$)	Continuous	LTC1046M (OBSOLETE)	$-55^{\circ}C$ to $125^{\circ}C$
		Storage Temperature Range	$-65^{\circ}C$ to $+150^{\circ}C$
		Lead Temperature (Soldering, 10 sec.)	300 $^{\circ}C$

PACKAGE/ORDER INFORMATION

<p>J8 PACKAGE 8-LEAD CERDIP $T_{JMAX} = 160^{\circ}C, \theta_{JA} = 100^{\circ}C$</p> <p>OBSOLETE PACKAGE Consider the N8 or S8 for Alternate Source</p>	ORDER PART NUMBER	<p>N8 PACKAGE 8-LEAD PDIP S8 PACKAGE 8-LEAD PLASTIC SO $T_{JMAX} = 110^{\circ}C, \theta_{JA} = 130^{\circ}C$ (N8) $T_{JMAX} = 150^{\circ}C, \theta_{JA} = 150^{\circ}C$ (S8)</p>	ORDER PART NUMBER
	LTC1046MJ8		LTC1046CN8 LTC1046CS8 LTC1046IN8 LTC1046IS8
			S8 PART MARKING
			1046 1046I

Consult LTC Marketing for parts specified with wider operating temperature ranges.

ELECTRICAL CHARACTERISTICS

The ● denotes the specifications which apply over the full operating temperature range, otherwise specifications are at $T_A = 25^{\circ}C$. $V^+ = 5V$, $C_{OSC} = 0pF$, unless otherwise noted.

SYMBOL	PARAMETER	CONDITIONS	LTC1046C			LTC1046I/M			UNITS
			MIN	TYP	MAX	MIN	TYP	MAX	
I_S	Supply Current	$R_L = \infty$, Pins 1 and 7 No Connection		165	300	165	300	μ A	
		$R_L = \infty$, Pins 1 and 7 No Connection, $V^+ = 3V$		35		35		μ A	
V^+_{L}	Minimum Supply Voltage	$R_L = 5k\Omega$	●	1.5		1.5		V	
V^+_{H}	Maximum Supply Voltage	$R_L = 5k\Omega$	●		6		6	V	
R_{OUT}	Output Resistance	$V^+ = 5V, I_L = 50mA$ (Note 3)		27	35	27	35	Ω	
			●	27	45	27	50	Ω	
		$V^+ = 2V, I_L = 10mA$	●	60	85	60	90	Ω	
f_{OSC}	Oscillator Frequency	$V^+ = 5V$ (Note 4)		20	30	20	30	kHz	
		$V^+ = 2V$		4	5.5	4	5.5	kHz	
P_{EFF}	Power Efficiency	$R_L = 2.4k\Omega$		95	97	95	97	%	
V_{OUTEFF}	Voltage Conversion Efficiency	$R_L = \infty$		97	99.9	97	99.9	%	
I_{OSC}	Oscillator Sink or Source Current	$V_{OSC} = 0V$ or V^+ Pin 1 = $0V$	●	4.2	35	4.2	40	μ A	
		Pin 1 = V^+	●	15	45	15	50	μ A	

ELECTRICAL CHARACTERISTICS

Note 1: Absolute Maximum Ratings are those values beyond which the life of the device may be impaired.

Note 2: Connecting any input terminal to voltages greater than V^+ or less than ground may cause destructive latch-up. It is recommended that no inputs from sources operating from external supplies be applied prior to power-up of the LTC1046.

Note 3: R_{OUT} is measured at $T_J = 25^\circ\text{C}$ immediately after power-on.

Note 4: f_{OSC} is tested with $C_{OSC} = 100\text{pF}$ to minimize the effects of test fixture capacitance loading. The 0pF frequency is correlated to this 100pF test point, and is intended to simulate the capacitance at pin 7 when the device is plugged into a test socket and no external capacitor is used.

TYPICAL PERFORMANCE CHARACTERISTICS (Using Test Circuit in Figure 1)

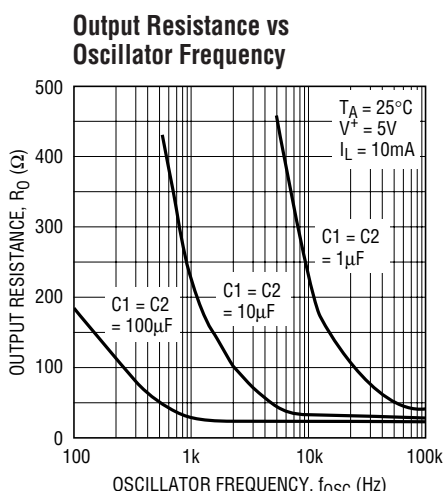

1046 G01

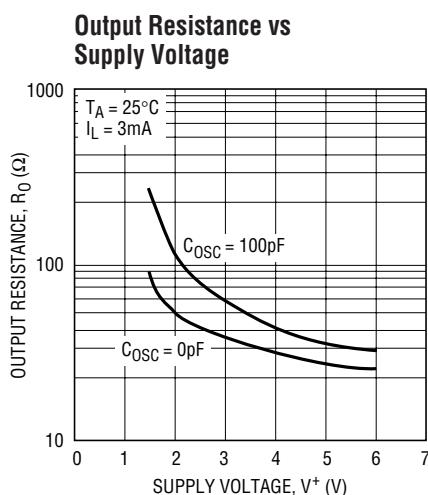

1046 G02

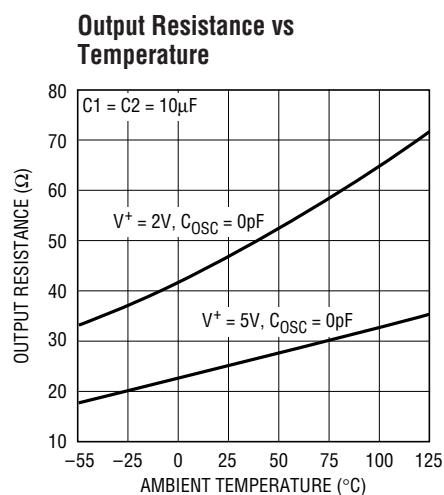

1046 G03

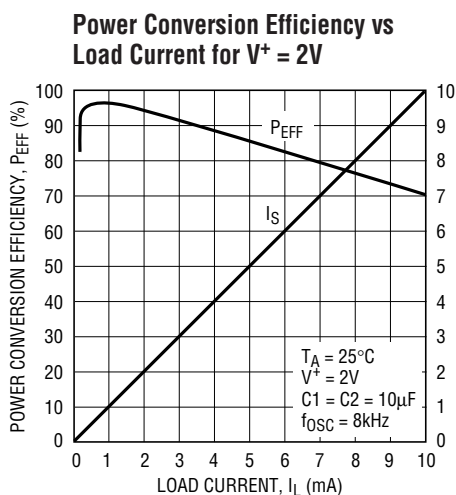

1046 G04

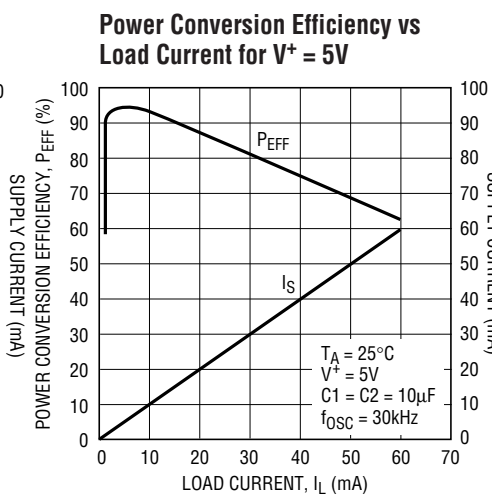

1046 G05

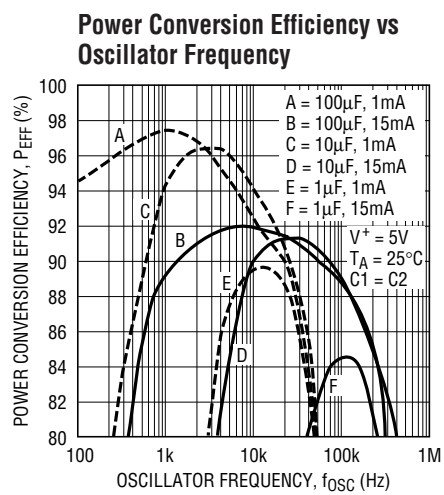

1046 G06

TYPICAL PERFORMANCE CHARACTERISTICS (Using Test Circuit in Figure 1)

Output Voltage vs Load Current for $V^+ = 2V$

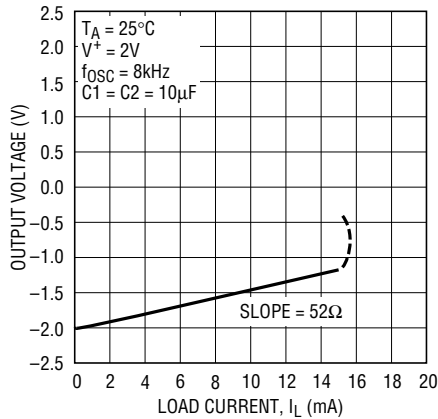

1046 G07

Output Voltage vs Load Current for $V^+ = 5V$

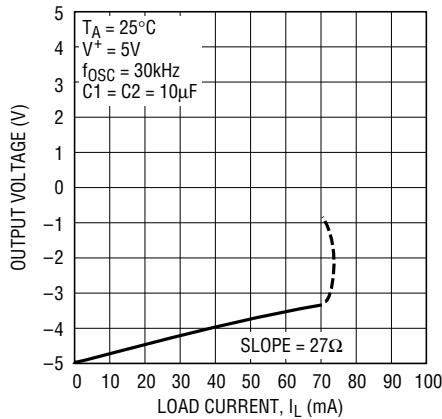

1046 G08

Oscillator Frequency as a Function of C_{OSC}

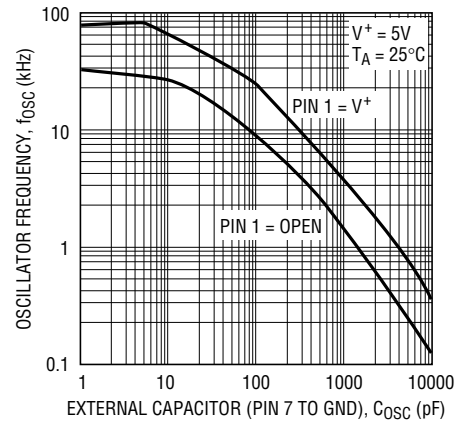

1046 G09

Oscillator Frequency as a Function of Supply Voltage

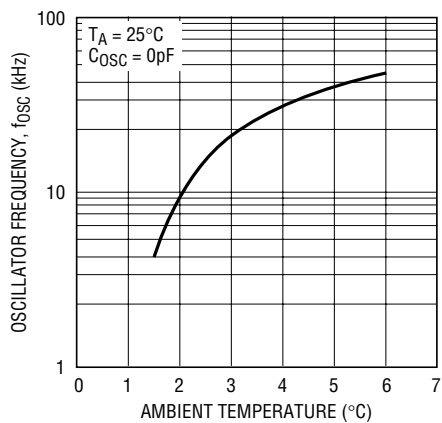

1046 G10

Oscillator Frequency vs Temperature

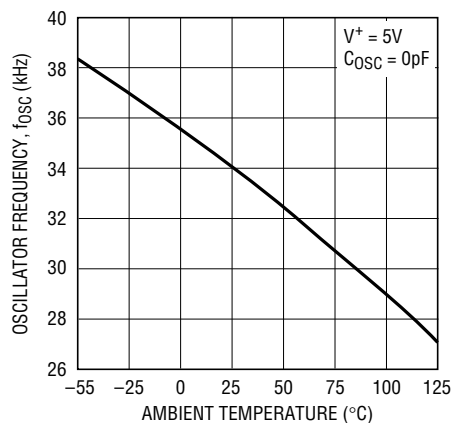

1046 G11

TEST CIRCUIT

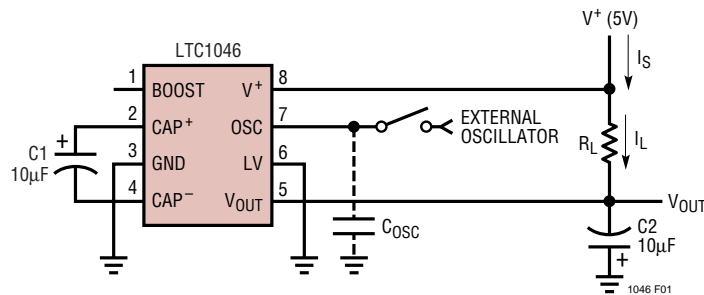

Figure 1

APPLICATIONS INFORMATION

Theory of Operation

To understand the theory of operation of the LTC1046, a review of a basic switched capacitor building block is helpful.

In Figure 2, when the switch is in the left position, capacitor C1 will charge to voltage V1. The total charge on C1 will be $q_1 = C_1V_1$. The switch then moves to the right, discharging C1 to voltage V2. After this discharge time, the charge on C1 is $q_2 = C_1V_2$. Note that charge has been transferred from the source, V1, to the output, V2. The amount of charge transferred is:

$$\Delta q = q_1 - q_2 = C_1(V_1 - V_2).$$

If the switch is cycled "f" times per second, the charge transfer per unit time (i.e., current) is:

$$I = f \cdot \Delta q = f \cdot C_1(V_1 - V_2).$$

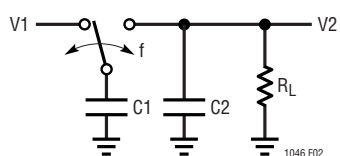

Figure 2. Switched Capacitor Building Block

Rewriting in terms of voltage and impedance equivalence,

$$I = \frac{V_1 - V_2}{(1/fC_1)} = \frac{V_1 - V_2}{R_{EQUIV}}.$$

A new variable, R_{EQUIV} , has been defined such that $R_{EQUIV} = 1/fC_1$. Thus, the equivalent circuit for the switched capacitor network is as shown in Figure 3.

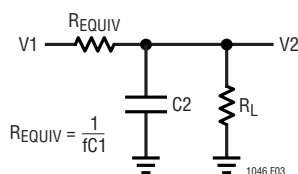

Figure 3. Switched Capacitor Equivalent Circuit

Examination of Figure 4 shows that the LTC1046 has the same switching action as the basic switched capacitor building block. With the addition of finite switch ON resistance and output voltage ripple, the simple theory, although not exact, provides an intuitive feel for how the device works.

For example, if you examine power conversion efficiency as a function of frequency (see typical curve), this simple theory will explain how the LTC1046 behaves. The loss, and hence the efficiency, is set by the output impedance. As frequency is decreased, the output impedance will eventually be dominated by the $1/fC_1$ term and power efficiency will drop. The typical curves for power efficiency versus frequency show this effect for various capacitor values.

Note also that power efficiency decreases as frequency goes up. This is caused by internal switching losses which occur due to some finite charge being lost on each switching cycle. This charge loss per unit cycle, when multiplied by the switching frequency, becomes a current loss. At high frequency this loss becomes significant and the power efficiency starts to decrease.

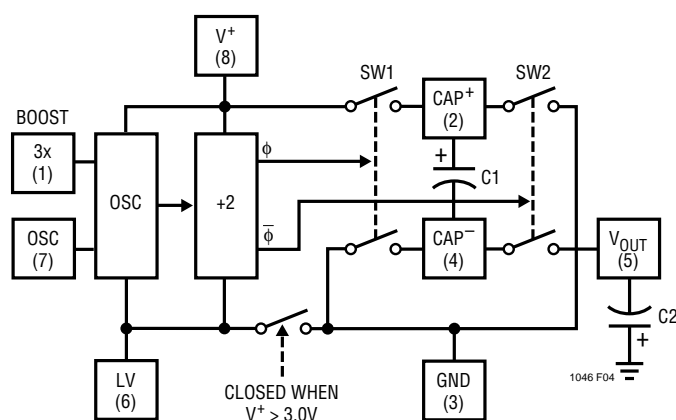

Figure 4. LTC1046 Switched Capacitor Voltage Converter Block Diagram

APPLICATIONS INFORMATION

LV (Pin 6)

The internal logic of the LTC1046 runs between V^+ and LV (Pin 6). For V^+ greater than or equal to 3V, an internal switch shorts LV to GND (Pin 3). For V^+ less than 3V, the LV pin should be tied to ground. For V^+ greater than or equal to 3V, the LV pin can be tied to ground or left floating.

OSC (Pin 7) and BOOST (Pin 1)

The switching frequency can be raised, lowered or driven from an external source. Figure 5 shows a functional diagram of the oscillator circuit.

By connecting the BOOST (Pin 1) to V^+ , the charge and discharge current is increased and, hence, the frequency is increased by approximately three times. Increasing the frequency will decrease output impedance and ripple for higher load currents.

Loading Pin 7 with more capacitance will lower the frequency. Using the BOOST pin in conjunction with external capacitance on Pin 7 allows user selection of the frequency over a wide range.

Driving the LTC1046 from an external frequency source can be easily achieved by driving Pin 7 and leaving the BOOST pin open, as shown in Figure 6. The output current from Pin 7 is small, typically $15\mu A$, so a logic gate is capable of driving this current. The choice of using a CMOS

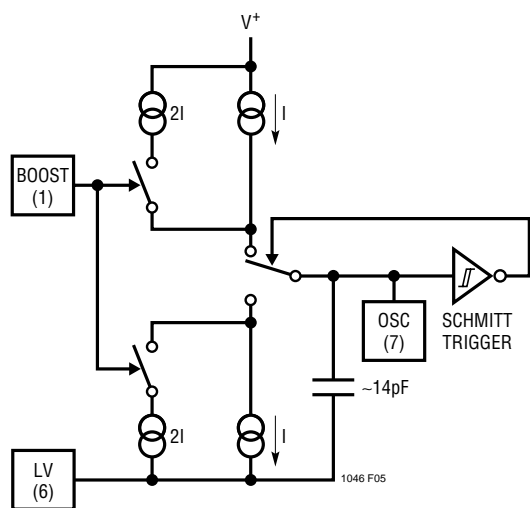

Figure 5. Oscillator

logic gate is best because it can operate over a wide supply voltage range (3V to 15V) and has enough voltage swing to drive the internal Schmitt trigger shown in Figure 5. For 5V applications, a TTL logic gate can be used by simply adding an external pull-up resistor (see Figure 6).

Capacitor Selection

While the exact values of C_{IN} and C_{OUT} are noncritical, good quality, low ESR capacitors such as solid tantalum are necessary to minimize voltage losses at high currents. For C_{IN} the effect of the ESR of the capacitor will be multiplied by four, due to the fact that switch currents are approximately two times higher than output current, and losses will occur on both the charge and discharge cycle. This means that using a capacitor with 1Ω of ESR for C_{IN} will have the same effect as increasing the output impedance of the LTC1046 by 4Ω . This represents a significant increase in the voltage losses. For C_{OUT} the effect of ESR is less dramatic. C_{OUT} is alternately charged and discharged at a current approximately equal to the output current, and the ESR of the capacitor will cause a step function to occur, in the output ripple, at the switch transitions. This step function will degrade the output regulation for changes in output load current, and should be avoided. Realizing that large value tantalum capacitors can be expensive, a technique that can be used is to parallel a smaller tantalum capacitor with a large aluminum electrolytic capacitor to gain both low ESR and reasonable cost. Where physical size is a concern some of the newer chip type surface mount tantalum capacitors can be used. These capacitors are normally rated at working voltages in the 10V to 20V range and exhibit very low ESR (in the range of 0.1Ω).

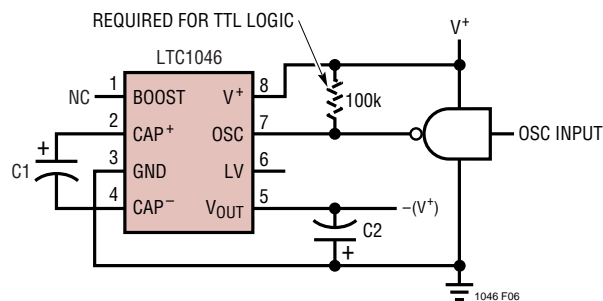

Figure 6. External Clocking

TYPICAL APPLICATIONS

Negative Voltage Converter

Figure 7 shows a typical connection which will provide a negative supply from an available positive supply. This circuit operates over full temperature and power supply ranges without the need of any external diodes. The LV pin (Pin 6) is shown grounded, but for $V^+ \geq 3V$, it may be floated, since LV is internally switched to GND (Pin 3) for $V^+ \geq 3V$.

The output voltage (Pin 5) characteristics of the circuit are those of a nearly ideal voltage source in series with an 27Ω resistor. The 27Ω output impedance is composed of two terms: 1) the equivalent switched capacitor resistance (see Theory of Operation), and 2) a term related to the ON resistance of the MOS switches.

At an oscillator frequency of 30kHz and $C1 = 10\mu F$, the first term is:

$$R_{EQUIV} = \frac{1}{(f_{OSC}/2) \cdot C1} = \frac{1}{15 \cdot 10^3 \cdot 10 \cdot 10^{-6}} = 6.7\Omega.$$

Notice that the equation for R_{EQUIV} is not a capacitive reactance equation ($X_C = 1/\omega C$) and does not contain a 2π term.

The exact expression for output impedance is complex, but the dominant effect of the capacitor is clearly shown on

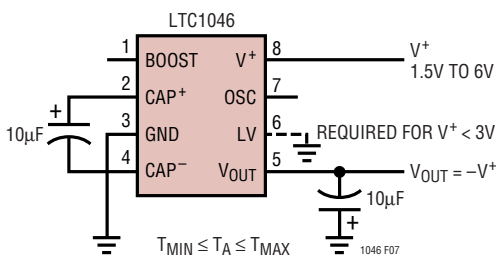

Figure 7. Negative Voltage Converter

the typical curves of output impedance and power efficiency versus frequency. For $C1 = C2 = 10\mu F$, the output impedance goes from 27Ω at $f_{OSC} = 30kHz$ to 225Ω at $f_{OSC} = 1kHz$. As the $1/fC$ term becomes large compared to switch ON resistance term, the output resistance is determined by $1/fC$ only.

Voltage Doubling

Figure 8 shows a two diode, capacitive voltage doubler. With a 5V input, the output is 9.1V with no load and 8.2V with a 10mA load.

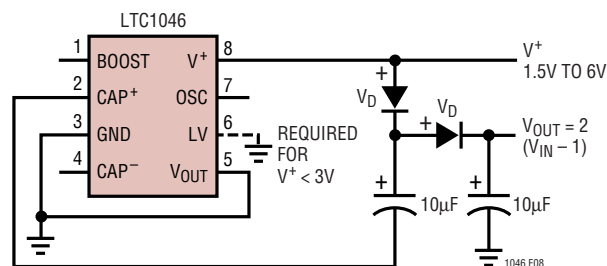

Figure 8. Voltage Doubler

Ultraprecision Voltage Divider

An ultraprecision voltage divider is shown in Figure 9. To achieve the 0.0002% accuracy indicated, the load current should be kept below 100nA. However, with a slight loss in accuracy, the load current can be increased.

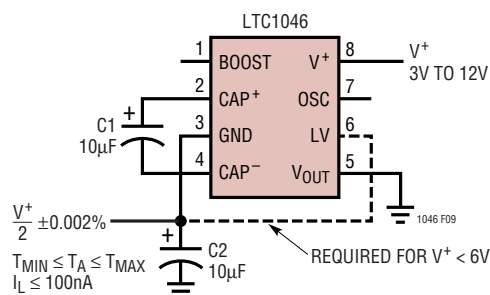

Figure 9. Ultraprecision Voltage Divider

TYPICAL APPLICATIONS

Battery Splitter

A common need in many systems is to obtain positive and negative supplies from a single battery or single power supply system. Where current requirements are small, the circuit shown in Figure 10 is a simple solution. It provides symmetrical positive or negative output voltages, both

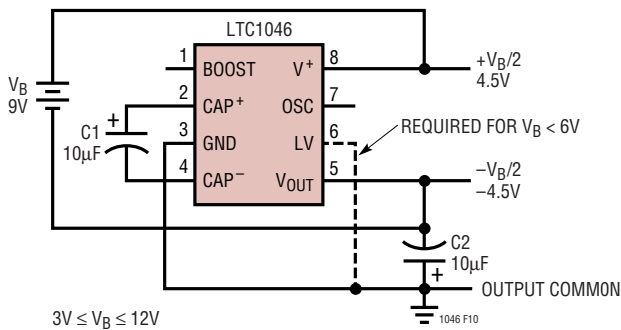

Figure 10. Battery Splitter

equal to one half the input voltage. The output voltages are both referenced to Pin 3 (output common). If the input voltage between Pin 8 and Pin 5 is less than 6V, Pin 6 should also be connected to Pin 3, as shown by the dashed line.

Paralleling for Lower Output Resistance

Additional flexibility of the LTC1046 is shown in Figures 11 and 12. Figure 11 shows two LTC1046s connected in parallel to provide a lower effective output resistance. If, however, the output resistance is dominated by $1/fC_1$, increasing the capacitor size (C_1) or increasing the frequency will be of more benefit than the paralleling circuit shown.

Figure 12 makes use of “stacking” two LTC1046s to provide even higher voltages. In Figure 12, a negative voltage doubler or tripler can be achieved depending upon how Pin 8 of the second LTC1046 is connected, as shown schematically by the switch.

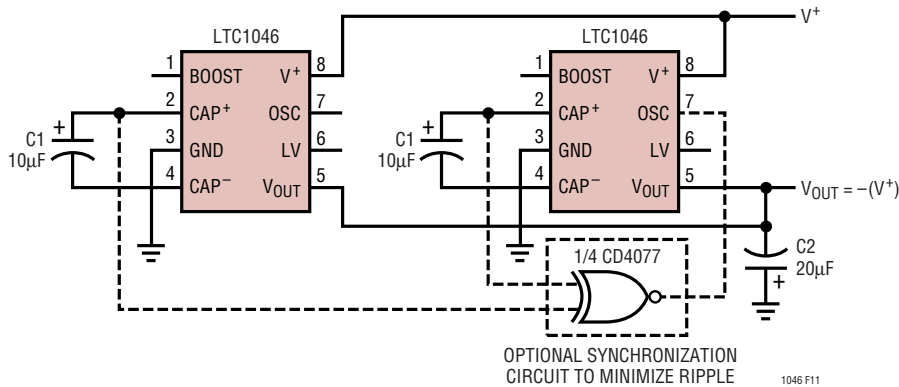

Figure 11. Paralleling for 100mA Load Current

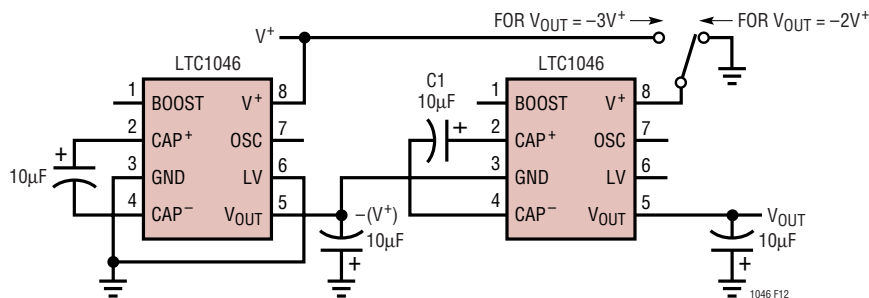
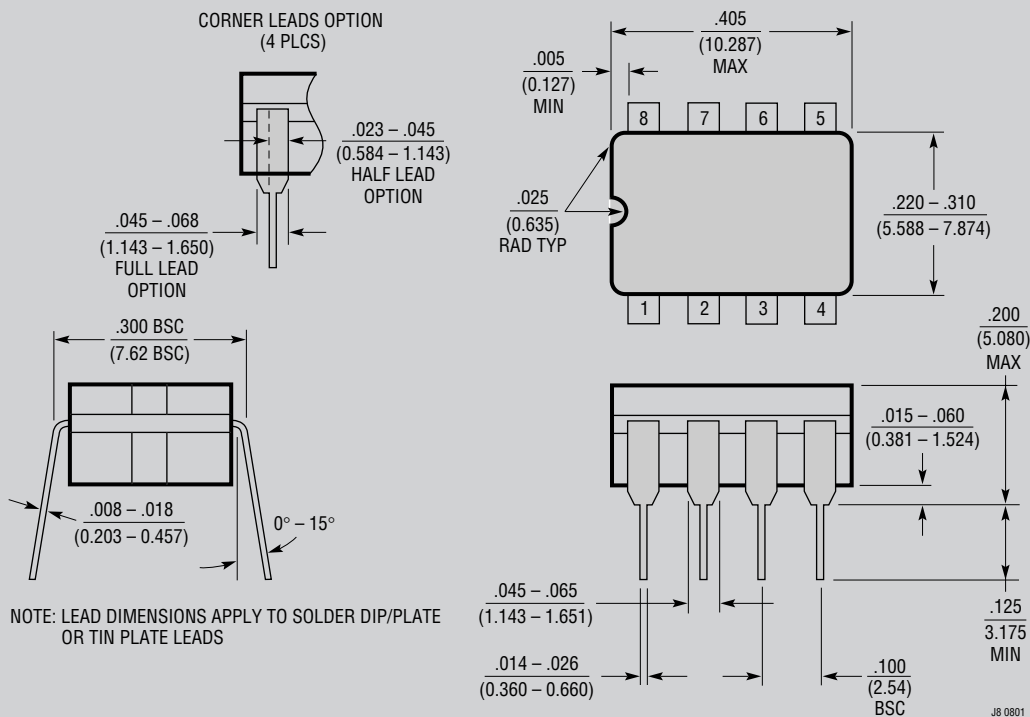

Figure 12. Stacking for Higher Voltage

PACKAGE DESCRIPTION

J8 Package 8-Lead CERDIP (Narrow .300 Inch, Hermetic) (Reference LTC DWG # 05-08-1110)



OBSOLETE PACKAGE

PACKAGE DESCRIPTION

N8 Package
8-Lead PDIP (Narrow .300 Inch)
 (Reference LTC DWG # 05-08-1510)

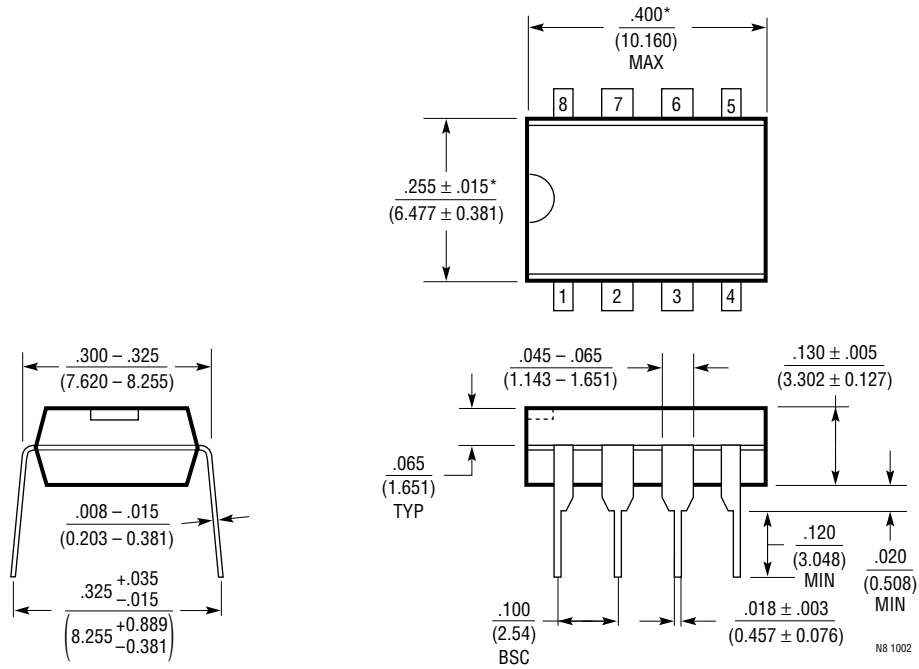

NOTE:
 1. DIMENSIONS ARE $\frac{\text{INCHES}}{\text{MILLIMETERS}}$
 *THESE DIMENSIONS DO NOT INCLUDE MOLD FLASH OR PROTRUSIONS.
 MOLD FLASH OR PROTRUSIONS SHALL NOT EXCEED .010 INCH (0.254mm)

N8 1002

PACKAGE DESCRIPTION

S8 Package 8-Lead Plastic Small Outline (Narrow .150 Inch) (Reference LTC DWG # 05-08-1610)

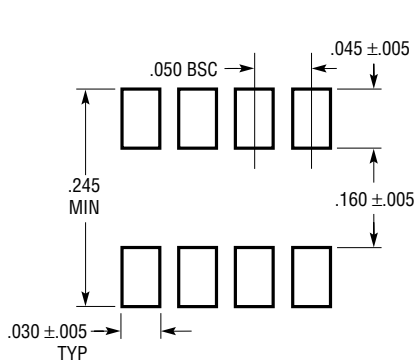

RECOMMENDED SOLDER PAD LAYOUT

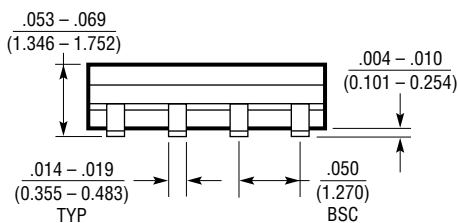
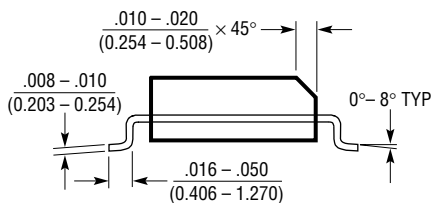
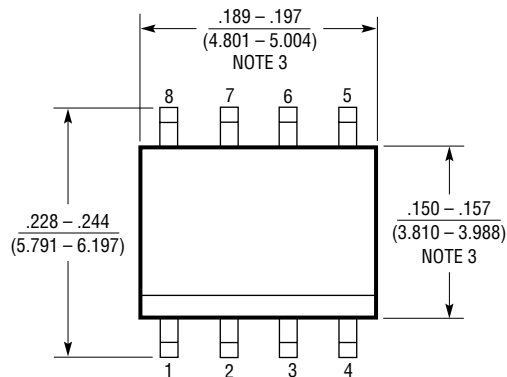

- NOTE:
 1. DIMENSIONS IN $\frac{\text{INCHES}}{\text{MILLIMETERS}}$
 2. DRAWING NOT TO SCALE
 3. THESE DIMENSIONS DO NOT INCLUDE MOLD FLASH OR PROTRUSIONS.
 MOLD FLASH OR PROTRUSIONS SHALL NOT EXCEED .006" (0.15mm)

S08 0303

RELATED PARTS

PART NUMBER	DESCRIPTION	COMMENTS
LTC1044A	12V CMOS Voltage Converter	Doubler or Inverter, 20mA I _{OUT} , 1.5V to 12V Input Range
LT [®] 1054	Switched Capacitor Voltage Converter with Regulator	Doubler or Inverter, 100mA I _{OUT} , SO-8 Package
LTC1550	Low Noise, Switched Capacitor Regulated Inverter	< 1mV _{P-P} Output Ripple, 900kHz Operation, SO-8 Package
LT1611	1.4MHz Inverting Switching Regulator	5V to -5V at 150mA, Low Output Noise, SOT-23 Package
LT1617	Micropower Inverting Switching Regulator	5V to -5V at 20μA Supply Current, SOT-23 Package
LTC1754-5	Micropower Regulated 5V Charge Pump in SOT-23	5V/50mA, 13μA Supply Current, 2.7V to 5.5V Input Range