

FEATURES

- **Charger Controller for 3- or 4-Cell Lithium-Ion Batteries**
- **High Conversion Efficiency: Up to 96%**
- **Output Currents Exceeding 4A**
- **±0.8% Charging Voltage Accuracy**
- **Built-In Charge Termination for Li-Ion Batteries**
- **AC Adapter Current Limiting Maximizes Charge Rate***
- Thermistor Input for Temperature Qualified Charging
- Wide Input Voltage Range: 6V to 28V
- 0.5V Dropout Voltage; Maximum Duty Cycle: 98%
- Programmable Charge Current: ±4% Accuracy
- Indicator Outputs for Charging, C/10 Current Detection, AC Adapter Present, Low Battery, Input Current Limiting and Faults
- Charging Current Monitor Output
- Available in a 24-Pin 4mm × 5mm QFN Package

APPLICATIONS

- Notebook Computers
- Portable Instruments
- Battery-Backup Systems
- Li-Ion Chargers

DESCRIPTION

The LTC[®]4007-1 is a constant-current/constant-voltage charger controller for 3- or 4-cell lithium-ion batteries. The PWM controller uses a synchronous, quasi-constant frequency, constant off-time architecture that will not generate audible noise even when using ceramic capacitors. Charging current is programmable to ±4% accuracy using a programming resistor. Charging current can also be monitored as a voltage across the programming resistor.

The output float voltage is pin programmed for cell count (3 cells or 4 cells) and chemistry (4.2V/4.1V). A timer, programmed by an external resistor, sets the total charge time.

The LTC4007-1 includes a thermistor input, which suspends charging if an unsafe temperature condition is detected. If the cell voltage is less than 3.25V, a low-battery indicator asserts and can be used to program a trickle charge current to safely charge depleted batteries. The FAULT pin is also asserted and charging terminates if the low-battery condition persists for more than 1/4 of the total charge time.

LT, LTC and LT are registered trademarks of Linear Technology Corporation. All other trademarks are the property of their respective owners.
 *Protected by U.S. Patents including 5723970.

TYPICAL APPLICATION

12.6V, 4A Li-Ion Battery Charger

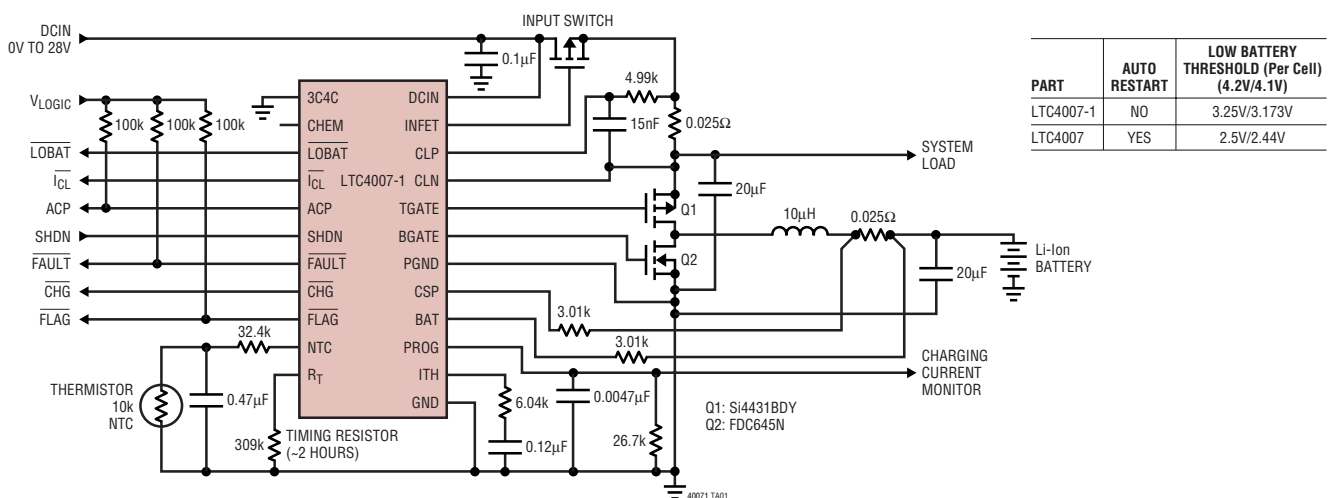

PART	AUTO RESTART	LOW BATTERY THRESHOLD (Per Cell) (4.2V/4.1V)
LTC4007-1	NO	3.25V/3.173V
LTC4007	YES	2.5V/2.44V

LTC4007-1

ABSOLUTE MAXIMUM RATINGS

(Note 1)

Voltage from DCIN, CLP, CLN to GND	+32V/−0.3V
PGND with Respect to GND	±0.3V
CSP, BAT to GND	+28V/−0.3V
CHEM, 3C4C, R _T to GND	+7V/−0.3V
NTC	+10V/−0.3V
ACP, SHDN, CHG, FLAG, FAULT, LOBAT, I _{CL}	+32V/−0.3V
CLP to CLN	±0.5V
Operating Ambient Temperature Range (Note 4)	−40°C to 85°C
Operating Junction Temperature	−40°C to 125°C
Storage Temperature Range	−65°C to 125°C

PACKAGE/ORDER INFORMATION

TOP VIEW

UFD PACKAGE
24-LEAD (4mm × 5mm) PLASTIC QFN
T_{JMAX} = 125°C, θ_{JA} = 90°C/W
EXPOSED PAD (PIN 25), GND AND PGND SHOULD BE CONNECTED TOGETHER WITH A LOW OHMIC CONNECTION.

ORDER PART NUMBER	UFD PART MARKING
LTC4007EUFD-1	40071

Order Options Tape and Reel: Add #TR
Lead Free: Add #PBF Lead Free Tape and Reel: Add #TRPBF
Lead Free Part Marking: <http://www.linear.com/leadfree/>

Consult LTC Marketing for parts specified with wider operating temperature ranges.

ELECTRICAL CHARACTERISTICS

The ● denotes specifications which apply over the full operating temperature range (Note 4), otherwise specifications are at T_A = 25°C. V_{DCIN} = 20V, V_{BAT} = 12V unless otherwise noted.

SYMBOL	PARAMETER	CONDITIONS	MIN	TYP	MAX	UNITS
	DCIN Operating Range		6		28	V
I _Q	Operating Current	Sum of Current from CLP, CLN, DCIN		3	5	mA
V _{TOL}	Charge Voltage Accuracy	Nominal Values: 12.3V, 12.6V, 16.4V, 16.8V (Note 2)	−0.8 −1.0		0.8 1.0	% %
I _{TOL}	Charge Current Accuracy (Note 3)	V _{CSP} − V _{BAT} Target = 100mV	−4 −5		4 5	% %
		V _{BAT} < 6V, V _{CSP} − V _{BAT} Target = 10mV		±60		%
		6V ≤ V _{BAT} ≤ V _{LOBAT} , V _{CSP} − V _{BAT} Target = 10mV		±35		%
T _{SAMPLE}	Measured Sample Time	R _{RT} = 1190k	● 42		60	ms
Shutdown						
	Battery Leakage Current	DCIN = 0V SHDN = 3V	● −10	20	35	μA μA
UVLO	Undervoltage Lockout Threshold	DCIN Rising, V _{BAT} = 0	● 4.2	4.7	5.5	V
	Shutdown Threshold at SHDN		● 1	1.6	2.5	V
	SHDN Pin Current			−10		μA
	Operating Current in Shutdown	V _{SHDN} = 0V, Sum of Current from CLP, CLN, DCIN		2	3	mA

40071f

ELECTRICAL CHARACTERISTICS

The ● denotes specifications which apply over the full operating temperature range (Note 4), otherwise specifications are at $T_A = 25^\circ\text{C}$. $V_{\text{DCIN}} = 20\text{V}$, $V_{\text{BAT}} = 12\text{V}$ unless otherwise noted.

SYMBOL	PARAMETER	CONDITIONS	MIN	TYP	MAX	UNITS	
Current Sense Amplifier, CA1							
	Input Bias Current Into BAT Pin			11.67		μA	
CMSL	CA1/I ₁ Input Common Mode Low		● 0			V	
CMSH	CA1/I ₁ Input Common Mode High		●		$V_{\text{CLN}} - 0.2$	V	
Current Comparators I_{CMP} and I_{REV}							
I _{TMAX}	Maximum Current Sense Threshold ($V_{\text{CSP}} - V_{\text{BAT}}$)	$V_{\text{ITH}} = 2.5\text{V}$	● 140	165	200	mV	
I _{TREV}	Reverse Current Threshold ($V_{\text{CSP}} - V_{\text{BAT}}$)			-30		mV	
Current Sense Amplifier, CA2							
	Transconductance			1		mmho	
	Source Current	Measured at I _{TH} , $V_{\text{ITH}} = 1.4\text{V}$		-40		μA	
	Sink Current	Measured at I _{TH} , $V_{\text{ITH}} = 1.4\text{V}$		40		μA	
Current Limit Amplifier							
	Transconductance			1.4		mmho	
V _{CLP}	Current Limit Threshold		● 93	100	107	mV	
I _{CLP}	CLP Input Bias Current			100		nA	
Voltage Error Amplifier, EA							
	Transconductance			1		mmho	
	Sink Current	Measured at I _{TH} , $V_{\text{ITH}} = 1.4\text{V}$		36		μA	
OVSD	Overvoltage Shutdown Threshold as a Percent of Programmed Charger Voltage		● 102	107	110	%	
Input P-Channel FET Driver (INFET)							
	DCIN Detection Threshold ($V_{\text{DCIN}} - V_{\text{CLN}}$)	DCIN Voltage Ramping Up from $V_{\text{CLN}} - 0.1\text{V}$	● 0	0.17	0.25	V	
	Forward Regulation Voltage ($V_{\text{DCIN}} - V_{\text{CLN}}$)		●	25	50	mV	
	Reverse Voltage Turn-Off Voltage ($V_{\text{DCIN}} - V_{\text{CLN}}$)	DCIN Voltage Ramping Down	● -60	-25		mV	
	INFET "On" Clamping Voltage ($V_{\text{DCIN}} - V_{\text{INFET}}$)	$I_{\text{INFET}} = 1\mu\text{A}$	● 5	5.8	6.5	V	
	INFET "Off" Clamping Voltage ($V_{\text{DCIN}} - V_{\text{INFET}}$)	$I_{\text{INFET}} = -25\mu\text{A}$			0.25	V	
Thermistor							
NTCVR	Reference Voltage During Sample Time			4.5		V	
	High Threshold	V_{NTC} Rising	●	NTCVR • 0.48	NTCVR • 0.5	NTCVR • 0.52	V
	Low Threshold	V_{NTC} Falling	●	NTCVR • 0.115	NTCVR • 0.125	NTCVR • 0.135	V
	Thermistor Disable Current	$V_{\text{NTC}} \leq 10\text{V}$			10	μA	
Indicator Outputs (ACP, CHG, FLAG, LOBAT, I_{CL}, FAULT)							
C10TOL	FLAG (C/10) Accuracy	Voltage Falling at PROG	● 0.375	0.397	0.420	V	
LBTOL	LOBAT Threshold Accuracy	3C4C = 0V, CHEM = 0V	● 9.233	9.519	9.805	V	
		3C4C = 0V, CHEM = Open	● 9.458	9.750	10.043	V	
		3C4C = Open, CHEM = 0V	● 12.311	12.692	13.074	V	
		3C4C = Open, CHEM = Open	● 12.610	13.000	13.390	V	
	I _{CL} Threshold Accuracy		83	93	105	mV	

ELECTRICAL CHARACTERISTICS

The ● denotes specifications which apply over the full operating temperature range (Note 4), otherwise specifications are at $T_A = 25^\circ\text{C}$. $V_{\text{DCIN}} = 20\text{V}$, $V_{\text{BAT}} = 12\text{V}$ unless otherwise noted.

SYMBOL	PARAMETER	CONDITIONS		MIN	TYP	MAX	UNITS
V_{OL}	Low Logic Level of ACP, $\overline{\text{CHG}}$, $\overline{\text{FLAG}}$, $\overline{\text{LOBAT}}$, $\overline{\text{I}_{\text{CL}}}$, FAULT	$I_{\text{OL}} = 100\mu\text{A}$	●			0.5	V
V_{OH}	High Logic Level of CHG, $\overline{\text{LOBAT}}$, $\overline{\text{I}_{\text{CL}}}$	$I_{\text{OH}} = -1\mu\text{A}$	●	2.7			V
I_{OFF}	Off State Leakage Current of ACP, $\overline{\text{FLAG}}$, FAULT	$V_{\text{OH}} = 3\text{V}$		-1		1	μA
I_{PO}	Pull-Up Current on $\overline{\text{CHG}}$, $\overline{\text{LOBAT}}$, $\overline{\text{I}_{\text{CL}}}$	$V = 0\text{V}$			-10		μA
	Timer Defeat Threshold at CHG			1			V

Programming Inputs (CHEM and 3C4C)

V_{IH}	High Logic Level		●			3.3	V
V_{IL}	Low Logic Level		●	1			V
I_{PI}	Pull-Up Current	$V = 0\text{V}$			-14		μA

Oscillator

f_{OSC}	Regulator Switching Frequency			255	300	345	kHz
f_{MIN}	Regulator Switching Frequency in Drop Out	Duty Cycle $\geq 98\%$		20	25		kHz
DC_{MAX}	Regulator Maximum Duty Cycle	$V_{\text{CSP}} = V_{\text{BAT}}$		98	99		%

Gate Drivers (TGATE, BGATE)

	$V_{\text{TGATE High}} (V_{\text{CLN}} - V_{\text{TGATE}})$	$I_{\text{TGATE}} = -1\text{mA}$				50	mV
	$V_{\text{BGATE High}}$	$C_{\text{LOAD}} = 3000\text{pF}$		4.5	5.6	10	V
	$V_{\text{TGATE Low}} (V_{\text{CLN}} - V_{\text{TGATE}})$	$C_{\text{LOAD}} = 3000\text{pF}$		4.5	5.6	10	V
	$V_{\text{BGATE Low}}$	$I_{\text{BGATE}} = 1\text{mA}$				50	mV
TGTR	TGATE Transition Time						
	TGATE Rise Time	$C_{\text{LOAD}} = 3000\text{pF}$, 10% to 90%			50	110	ns
TGTF	TGATE Fall Time	$C_{\text{LOAD}} = 3000\text{pF}$, 10% to 90%			50	100	ns
BGTR	BGATE Transition Time						
	BGATE Rise Time	$C_{\text{LOAD}} = 3000\text{pF}$, 10% to 90%			40	90	ns
BGTF	BGATE Fall Time	$C_{\text{LOAD}} = 3000\text{pF}$, 10% to 90%			40	80	ns
	$V_{\text{TGATE at Shutdown}} (V_{\text{CLN}} - V_{\text{TGATE}})$	$I_{\text{TGATE}} = -1\mu\text{A}$, $\text{DCIN} = 0\text{V}$, $\text{CLN} = 12\text{V}$				100	mV
	$V_{\text{BGATE at Shutdown}}$	$I_{\text{BGATE}} = 1\mu\text{A}$, $\text{DCIN} = 0\text{V}$, $\text{CLN} = 12\text{V}$				100	mV

Note 1: Absolute Maximum Ratings are those values beyond which the life of a device may be impaired.

Note 2: See Test Circuit.

Note 3: Does not include tolerance of current sense resistor or current programming resistor.

Note 4: The LTC4007E-1 is guaranteed to meet performance specifications from 0°C to 85°C . Specifications over the -40°C to 85°C operating temperature range are assured by design, characterization and correlation with statistical process controls.

TYPICAL PERFORMANCE CHARACTERISTICS

INFET Response Time to Reverse Current

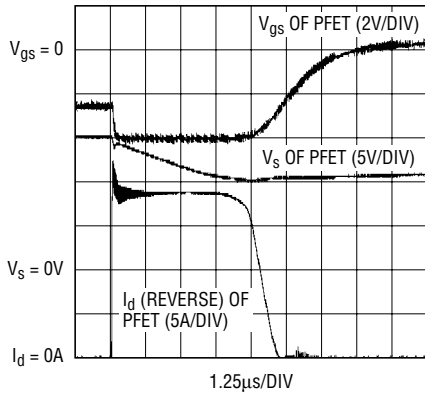

TEST PERFORMED ON DEMOBOARD
 $V_{IN} = 15VDC$ $V_{CHARGE} = 12.6V$
 CHARGER = ON PFET = 1/2 Si4925DY
 $I_{CHARGE} < 10mA$ 40071 G01

Line Regulation

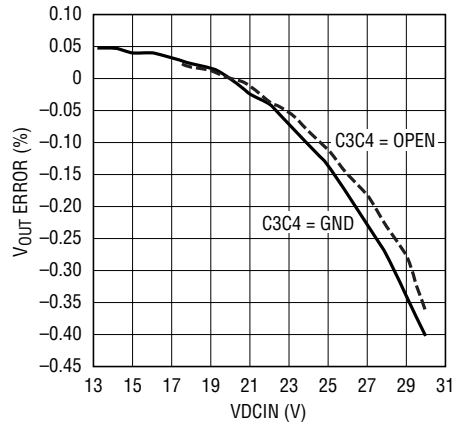

40071 G02

V_{OUT} vs I_{OUT}

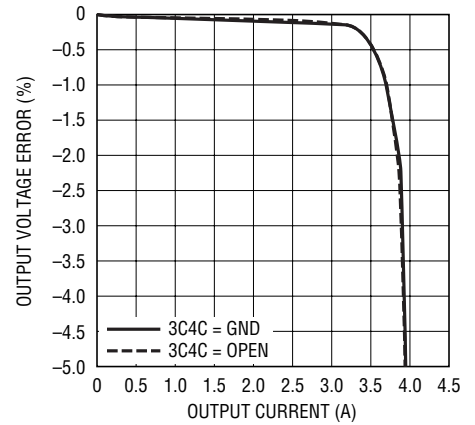

40071 G03

PWM Frequency vs Duty Cycle

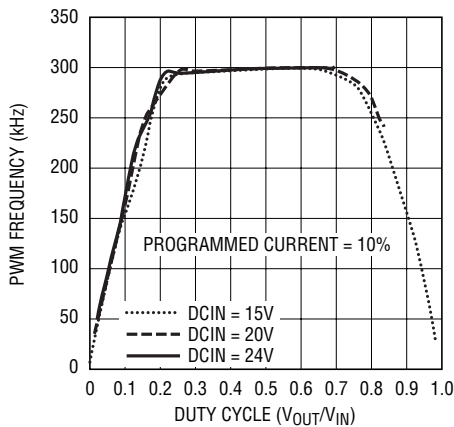

40071 G04

Disconnect/Reconnect Battery (Load Dump)

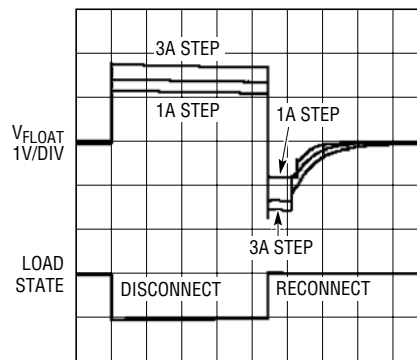

LOAD CURRENT = 1A, 2A, 3A
 $DCIN = 20V$
 $V_{FLOAT} = 12.6V$ (3C4C = GND, CHEM = OPEN)
 40071 G05

1A Load Step (Battery Present)

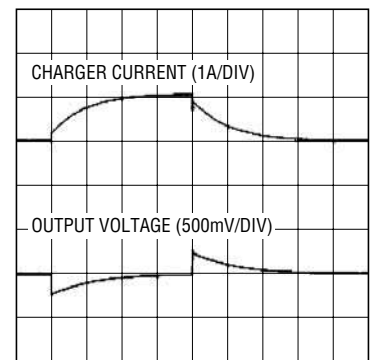

$DCIN = 20V$
 $V_{FLOAT} = 12.6V$

40071 G06

1A Load Step (Battery Not Present)

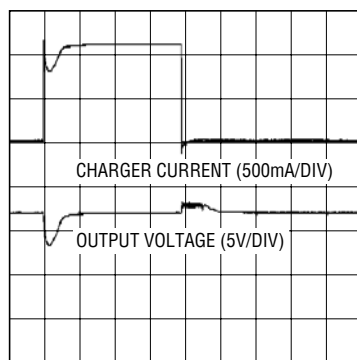

$DCIN = 20V$
 $V_{FLOAT} = 12.6V$

40071 G07

Battery Leakage Current vs Battery Voltage

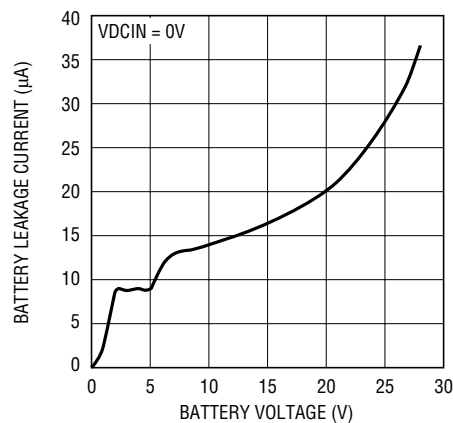

40071 G08

TYPICAL PERFORMANCE CHARACTERISTICS

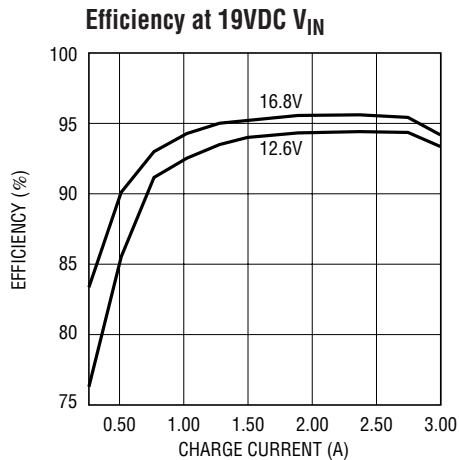

40071 G10

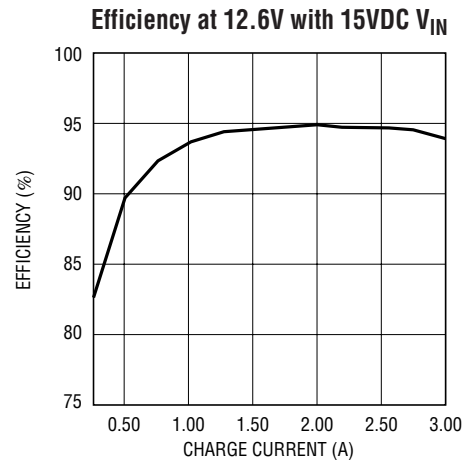

40071 G11

PIN FUNCTIONS

ACP (Pin 1): Open-Drain output to indicate if the AC adapter voltage is adequate for charging. This pin is pulled low by an internal N-channel MOSFET if DCIN is below BAT. A pull-up resistor is required. The pin is capable of sinking at least 100 μ A.

R_T (Pin 2): Timer Resistor. The timer period is set by placing a resistor, R_{RT} , to GND. This resistor is always required.

$$\text{The timer period is } t_{\text{TIMER}} = (1\text{hour} \cdot R_{RT}/154\text{K}).$$

If this resistor is not present, the charger will not start.

FAULT (Pin 3): Active low open-drain output that indicates charger operation has stopped due to a low-battery conditioning error, or that charger operation is suspended due to the thermistor exceeding allowed values. A pull-up resistor is required if this function is used. The pin is capable of sinking at least 100 μ A.

GND (Pin 4): Ground for Low Power Circuitry.

3C4C (Pin 5): Select 3-cell or 4-cell float voltage by connecting this pin to GND or open, respectively. Internal 14 μ A pull-up to 5.3V. This pin can also be driven with open-collector/drain logic levels. High: 4 cell. Low: 3 cell.

LOBAT (Pin 6): Low-Battery Indicator. Active low digital output. Internal 10 μ A pull-up to 3.5V. If the battery voltage is below 3.25V/cell (or 3.173V/cell for 4.1V chemistry batteries) LOBAT will be low. The pin is capable of sinking at least 100 μ A. If V_{LOGIC} is greater than 3.3V, add an external pull-up.

NTC (Pin 7): A thermistor network is connected from NTC to GND. This pin determines if the battery temperature is safe for charging. The charger and timer are suspended and the FAULT pin is driven low if the thermistor indicates a temperature that is unsafe for charging. The thermistor function may be disabled with a 300k to 500k resistor from DCIN to NTC.

ITH (Pin 8): Control Signal of the Inner Loop of the Current Mode PWM. Higher ITH voltage corresponds to higher charging current in normal operation. A 6k resistor, in series with a capacitor of at least 0.1 μ F to GND provides loop compensation. Typical full-scale output current is 40 μ A. Nominal voltage range for this pin is 0V to 3V.

40071f

PIN FUNCTIONS

PROG (Pin 9): Current Programming/Monitoring Input/Output. An external resistor to GND programs the peak charging current in conjunction with the current sensing resistor. The voltage at this pin provides a linear indication of charging current. Peak current is equivalent to 1.19V. Zero current is approximately 0.3V. A capacitor from PROG to ground is required to filter higher frequency components. The maximum resistance to ground is 100k. Values higher than 100k can cause the charger to shut down.

$\overline{I_{CL}}$ (Pin 10): Input Current Limit Indicator. Active low digital output. Internal 10 μ A pull-up to 3.5V. Pulled low if the charger current is being reduced by the input current limiting function. The pin is capable of sinking at least 100 μ A. If V_{LOGIC} is greater than 3.3V, add an external pull-up.

CSP (Pin 11): Current Amplifier CA1 Input. The CSP and BAT pins measure the voltage across the sense resistor, R_{SENSE} , to provide the instantaneous current signals required for both peak and average current mode operation.

BAT (Pin 12): Battery Sense Input and the Negative Reference for the Current Sense Resistor. A precision internal resistor divider sets the final float potential on this pin. The resistor divider is disconnected during shutdown.

CHEM (Pin 13): Select 4.1V or 4.2V cell chemistry by connecting the pin to GND or open, respectively. Internal 14 μ A pull-up to 5.3V. Can also be driven with open-collector/drain logic levels.

FLAG (Pin 14): Active low open-drain output that indicates when charging current has declined to 10% of maximum programmed current. A pull-up resistor is required if this function is used. The pin is capable of sinking at least 100 μ A.

CLP (Pin 15): Positive input to the supply current limiting amplifier, CL1. The threshold is set at 100mV above the voltage at the CLN pin. When used to limit supply current, a filter is needed to filter out the switching noise. If no current limit function is desired, connect this pin to CLN.

CLN (Pin 16): Negative Reference for the Input Current Limit Amplifier, CL1. This pin also serves as the power supply for the IC. A 10 μ F to 22 μ F bypass capacitor should be connected as close as possible to this pin.

TGATE (Pin 17): Drives the top external P-channel MOSFET of the battery charger buck converter.

PGND (Pin 18): High Current Ground Return for the BGATE Driver.

NC (Pin 19): No Connect.

BGATE (Pin 20): Drives the bottom external N-channel MOSFET of the battery charger buck converter.

INFET (Pin 21): Drives the Gate of the External Input PFET.

SHDN (Pin 22): Charger is shut down and timer is reset when this pin is HIGH. Internal 10 μ A pull-up to 3.5V. This pin can also be used to reset the charger by applying a positive pulse that is a minimum of 0.1 μ s long.

DCIN (Pin 23): External DC Power Source Input. Bypass this pin with at least 0.01 μ F. See Applications Information.

\overline{CHG} (Pin 24): Charge Status Output. When the battery is being charged, the \overline{CHG} pin is pulled low by an internal N-channel MOSFET. Internal 10 μ A pull-up to 3.5V. If V_{LOGIC} is greater than 3.3V, add an external pull-up. The timer function can be defeated by forcing this pin below 1V (or connecting it to GND).

Exposed Pad (Pin 25): The exposed pad, GND and PGND should be connected together with a low ohmic connection.

BLOCK DIAGRAM

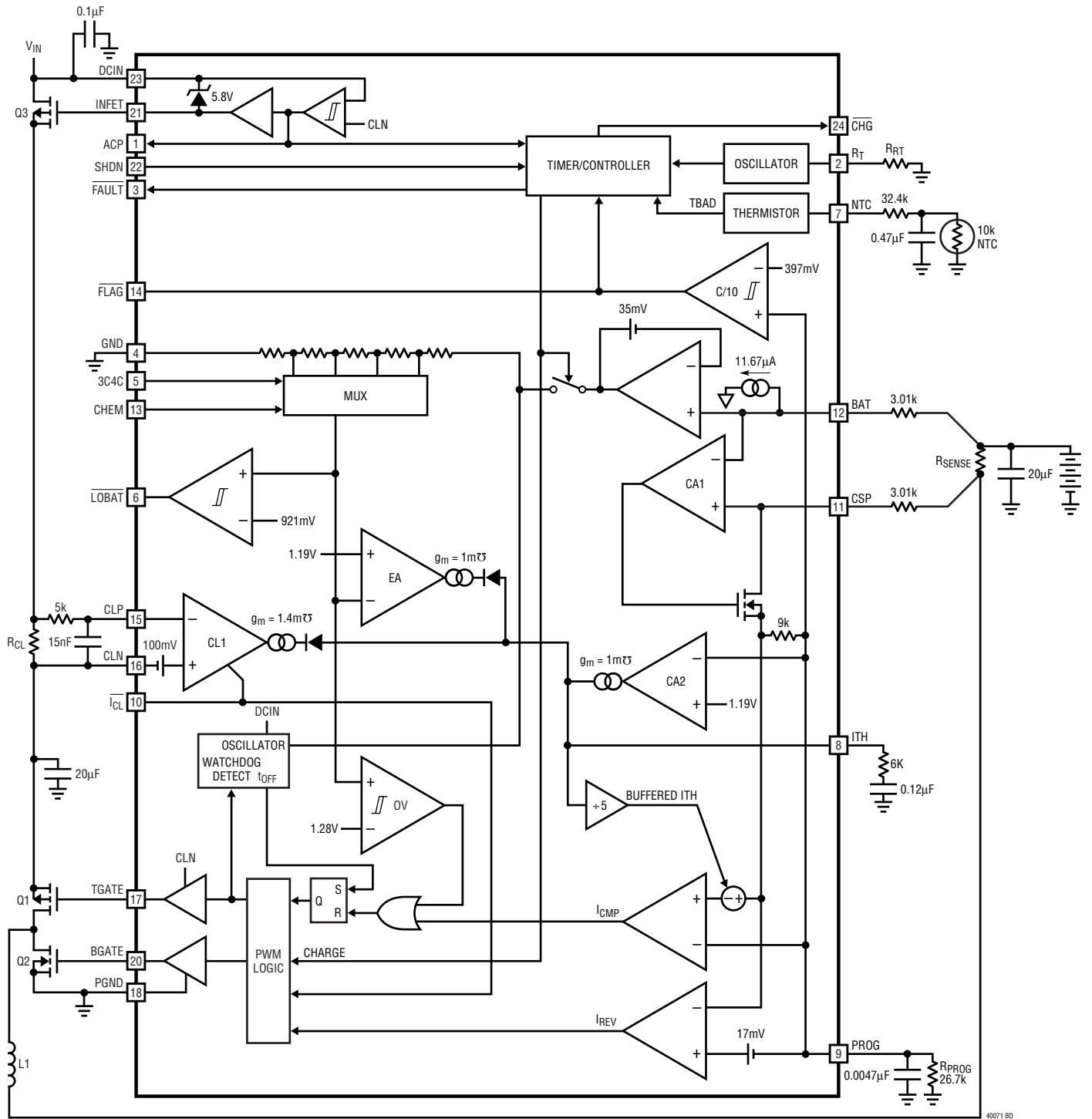

40071 BD

TEST CIRCUIT

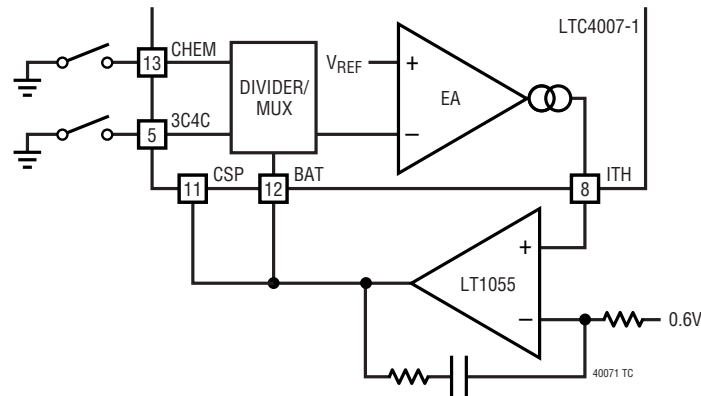

OPERATION

Overview

The LTC4007-1 is a synchronous current mode PWM step-down (buck) switcher battery charger controller. The charge current is programmed by the combination of a program resistor (R_{PROG}) from the PROG pin to ground and a sense resistor (R_{SENSE}) between the CSP and BAT pins. The final float voltage is programmed to one of four values (12.3V, 12.6V, 16.4V, 16.8V) with $\pm 1\%$ maximum accuracy using pins 3C4C and CHEM. Charging begins when the potential at the DCIN pin rises above the voltage at BAT (and the UVLO voltage) and the SHDN pin is low; the CHG pin is set low. At the beginning of the charge cycle, if the cell voltage is below 3.25V (3.173V if CHEM is low), the LOBAT pin will be low. The LOBAT indicator can be used to reduce the charging current to a low value, typically 10% of full scale. If the cell voltage stays below 3.25V for 25% of the total charge time, the charge sequence will be terminated immediately and the FAULT pin will be set low.

An external thermistor network is sampled at regular intervals. If the thermistor value exceeds design limits, charging is suspended and the FAULT pin is set low. If the thermistor value returns to an acceptable value, charging resumes and the FAULT pin is set high. An external resistor on the R_T pin sets the total charge time. The timer can be defeated by forcing the CHG pin to a low voltage.

As the battery approaches the final float voltage, the charge current will begin to decrease. When the current

drops to 10% of the full-scale charge current, an internal C/10 comparator will indicate this condition by latching the FLAG pin low. The charge timer is also reset to 1/4 of the total charge time when FLAG goes low. If this condition is caused by an input current limit condition, described below, then the FLAG indicator will be inhibited. When a time-out occurs, charging is terminated immediately and the CHG pin is forced to a high impedance state. To restart the charge cycle manually, simply remove the input voltage and reapply it, or set the SHDN pin high momentarily. When the input voltage is not present, the charger goes into a sleep mode, dropping battery current drain to 15 μ A. This greatly reduces the current drain on the battery and increases the standby time. The charger is inhibited any time the SHDN pin is high.

Input FET

The input FET circuit performs two functions. It enables the charger if the input voltage is higher than the CLN pin and provides the logic indicator of AC present on the ACP pin. It controls the gate of the input FET to keep a low forward voltage drop when charging and also prevents reverse current flow through the input FET.

If the input voltage is less than V_{CLN} , it must go at least 170mV higher than V_{CLN} to activate the charger. When this occurs the ACP pin is released and pulled up with an external load to indicate that the adapter is present. The

OPERATION

Table 1. Truth Table for LTC4007-1 Operation (Supplemental)

NUMBER	FROM STATE	TO STATE	MODE	DCIN	BATTERY VOLTAGE	PRESENT C/10 LATCH	NEXT C/10 LATCH	MAX BATTERY CURRENT	ACP	TIMER STATE	CHG
1	Any	MSD	Shut Down by Low Adapter Voltage	<BAT			0	OFF	LOW	Reset	HIGH
2	MSD	SD	Charger Shutdown	>BAT			0	OFF	HIGH	Reset	HIGH
3	SD, CONDITION, CHARGE	SD	Shut Down by Undervoltage Lockout	>BAT and <UVL				OFF	HIGH	Reset	HIGH*
4	SD	CONDITION	Start Conditioning a Depleted Battery	>BAT	<3.25V/Cell			10% Programmed Current	HIGH		LOW
5	CONDITION	CONDITION	Input Current Limited Condition Charging	>BAT	<3.25V/Cell			<10% Programmed Current (Note 2)	HIGH	Running	LOW
6	CONDITION	CONDITION	Conditioning a Depleted Battery	>BAT	<3.25V/Cell			10% Programmed Current	HIGH	Running	LOW
7	CONDITION	CONDITION	Timer Defeated (Low Battery Conditioning Still Functional)	>BAT	<3.25V/Cell			10% Programmed Current	HIGH	Ignored	Forced LOW
8	CONDITION	SD	Charger Paused Due to Thermistor Out of Range	>BAT	<3.25V/Cell			OFF	HIGH	Paused	LOW (Faulted)
9	CONDITION	SD	Timeout in CONDITION Mode	>BAT	<3.25V/Cell			OFF	HIGH	>T/4	HIGH (Faulted)
10	CONDITION	SD	Shut Down by ACP/SHDN Pin	>BAT	<3.25V/Cell		0	OFF	Forced LOW	Reset	HIGH
11	CONDITION	CHARGE	Start Normal Charging	>BAT	>3.25V/Cell			Programmed Current	HIGH	Running	
12	CHARGE	CHARGE	Timer Defeated (Low Battery Conditioning Still Functional)	>BAT	>3.25V/Cell			Programmed Current	HIGH	Ignored	Forced LOW
13	CHARGE	CHARGE	Top-Off Charging	>BAT	>3.25V/Cell	0		Programmed Current	HIGH	Running	LOW
14	CHARGE	CHARGE	C/10 Latch is SET when Battery Current Is Less than 10% of Programmed Current	>BAT	>3.25V/Cell		1	Programmed Current	HIGH	Reset	25 μ A
15	CHARGE	CHARGE	Top-Off Charging	>BAT	>3.25V/Cell	1		Programmed Current	HIGH	Running	25 μ A
16	CHARGE	CHARGE	Input Current Limited Charging	>BAT	>3.25V/Cell			<Programmed Current (Note 2)	HIGH		
17	CHARGE	SD	Charger Paused Due to Thermistor Out of Range	>BAT	>3.25V/Cell			OFF	HIGH	Paused	LOW or 25 μ A (Faulted)
18	CHARGE	SD	Shut Down by ACP/SHDN Pin	>BAT	>3.25V/Cell		0	OFF	Forced LOW	Reset	HIGH
19	CHARGE	SD	Terminated by Low-Battery Fault (Note 1)	>BAT	<3.25V/Cell		0	OFF	HIGH	>T/4 then Reset	HIGH (Faulted)
20	CHARGE	SD	Terminates After T/4	>BAT	V _{FLOAT}	1		OFF	HIGH	>T/4 then Reset	HIGH
21	CHARGE	SD	Terminates After T	>BAT	V _{FLOAT} *	0		OFF	HIGH	>T then Reset	HIGH

*Most probable condition

Note 1: If a depleted battery is inserted while the charger is in this state, the charger must be reset to initiate charging.

Note 2: See section on "Adapter Limiting".

Note 3: Blank fields indicate no change, not considered, or other states impact value.

Note 4: Battery voltage thresholds do not include comparator hysteresis. Thresholds specify the VLH value.

OPERATION

LTC4007-1: State Diagram

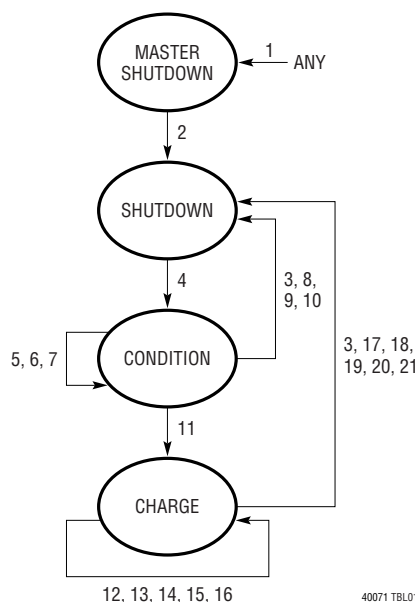

gate of the input FET is driven to a voltage sufficient to keep a low forward voltage drop from drain to source. If the voltage between DCIN and CLN drops to less than 25mV, the input FET is turned off slowly. If the voltage between DCIN and CLN is ever less than -25mV, then the input FET is turned off in less than 10μs to prevent significant reverse current from flowing in the input FET. In this condition, the ACP pin is driven low and the charger is disabled.

Battery Charger Controller

The LTC4007-1 charger controller uses a constant off-time, current mode step-down architecture. During normal operation, the top MOSFET is turned on each cycle when the oscillator sets the SR latch and turned off when the main current comparator I_{CMP} resets the SR latch. While the top MOSFET is off, the bottom MOSFET is turned on until either the inductor current trips the current comparator I_{REV} or the beginning of the next cycle. The oscillator uses the equation:

$$t_{OFF} = \frac{V_{DCIN} - V_{BAT}}{V_{DCIN} \cdot f_{OSC}}$$

to set the bottom MOSFET on time. The result is a nearly constant switching frequency over a wide input/output voltage range. This activity is diagrammed in Figure 1.

The peak inductor current, at which I_{CMP} resets the SR latch, is controlled by the voltage on ITH. ITH is in turn controlled by several loops, depending upon the situation at hand. The average current control loop converts the voltage between CSP and BAT to a representative current. Error amp CA2 compares this current against the desired current programmed by R_{PROG} at the PROG pin and

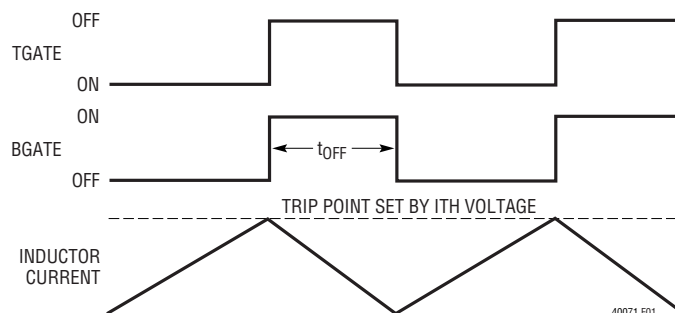

Figure 1

OPERATION

adjusts ITH until:

$$\frac{V_{REF}}{R_{PROG}} = \frac{V_{CSP} - V_{BAT} + 11.67\mu A \cdot 3.01k\Omega}{3.01k\Omega}$$

therefore,

$$I_{CHARGE(MAX)} = \left(\frac{V_{REF}}{R_{PROG}} - 11.67\mu A \right) \cdot \frac{3.01k\Omega}{R_{SENSE}}$$

The voltage at BAT is divided down by an internal resistor divider and is used by error amp EA to decrease ITH if the divider voltage is above the 1.19V reference. When the charging current begins to decrease, the voltage at PROG will decrease in direct proportion. The voltage at PROG is then given by:

$$V_{PROG} = (I_{CHARGE} \cdot R_{SENSE} + 11.67\mu A \cdot 3.01k\Omega) \cdot \frac{R_{PROG}}{3.01k\Omega}$$

V_{PROG} is plotted in Figure 2.

The amplifier CL1 monitors and limits the input current, normally from the AC adapter to a preset level (100mV/ R_{CL}). At input current limit, CL1 will decrease the ITH voltage, thereby reducing charging current. The I_{CL} indicator output will go low when this condition is detected and the $FLAG$ indicator will be inhibited if it is not already LOW.

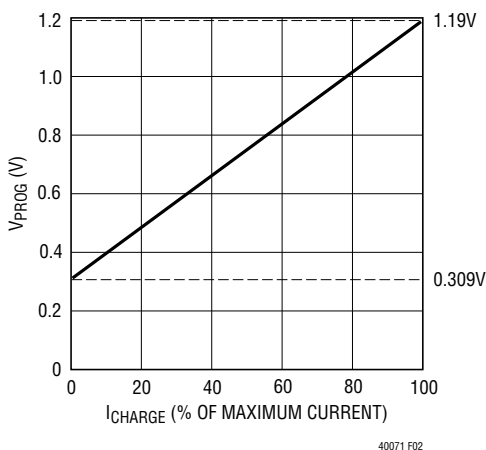

Figure 2. V_{PROG} vs I_{CHARGE}

If the charging current decreases below 10% to 15% of programmed current while engaged in input current limiting, BGATE will be forced low to prevent the charger from discharging the battery. Audible noise can occur in this mode of operation.

An overvoltage comparator guards against voltage transient overshoots (>7% of programmed value). In this case, both MOSFETs are turned off until the overvoltage condition is cleared. This feature is useful for batteries which “load dump” themselves by opening their protection switch to perform functions such as calibration or pulse mode charging.

PWM Watchdog Timer

There is a watchdog timer that observes the activity on the BGATE and TGATE pins. If TGATE stops switching for more than 40 μ s, the watchdog activates and turns off the top MOSFET for about 400ns. The watchdog engages to prevent very low frequency operation in dropout—a potential source of audible noise when using ceramic input and output capacitors.

Charger Start-Up

When the charger is enabled, it will not begin switching until the ITH voltage exceeds a threshold that assures initial current will be positive. This threshold is 5% to 15% of the maximum programmed current. After the charger begins switching, the various loops will control the current at a level that is higher or lower than the initial current. The duration of this transient condition depends upon the loop compensation, but is typically less than 100 μ s.

Thermistor Detection

The thermistor detection circuit is shown in Figure 3. It requires an external resistor and capacitor in order to function properly.

The thermistor detector performs a sample-and-hold function. An internal clock, whose frequency is determined by

OPERATION

the timing resistor connected to R_T , keeps switch $S1$ closed to sample the thermistor:

$$t_{SAMPLE} = 127.5 \cdot 20 \cdot R_{RT} \cdot 17.5\text{pF} = 13.8\text{ms},$$

for $R_{RT} = 309\text{k}$

The external RC network is driven to approximately 4.5V and settles to a final value across the thermistor of:

$$V_{RTH(FINAL)} = \frac{4.5V \cdot R_{TH}}{R_{TH} + R_9}$$

This voltage is stored by $C7$. Then the switch is opened for a short period of time to read the voltage across the thermistor.

$$t_{HOLD} = 10 \cdot R_{RT} \cdot 17.5\text{pF} = 54\mu\text{s},$$

for $R_{RT} = 309\text{k}$

When the t_{HOLD} interval ends the result of the thermistor testing is stored in the D flip-flop (DFF). If the voltage at NTC is within the limits provided by the resistor divider feeding the comparators, then the NOR gate output will be low and the DFF will set T_{BAD} to zero and charging will continue. If the voltage at NTC is outside of the resistor divider limits, then the DFF will set T_{BAD} to one, the charger will be shut down, $FAULT$ pin is set low and the timer will be suspended until T_{BAD} returns to zero (see Figure 4).

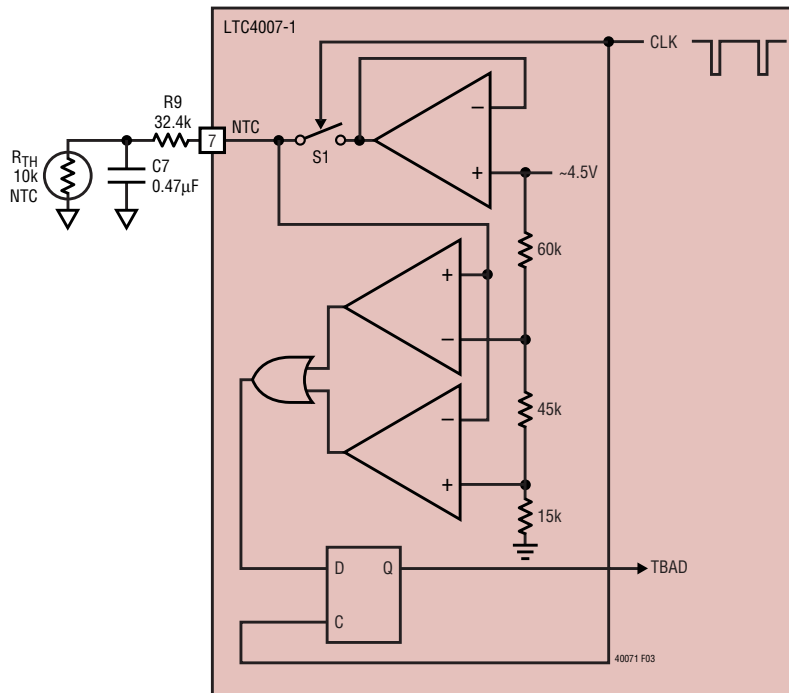

Figure 3

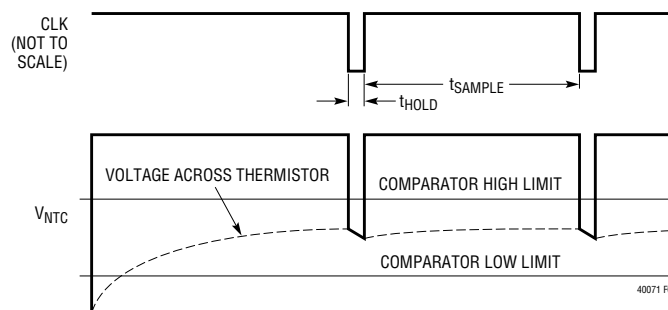

Figure 4

APPLICATIONS INFORMATION

Battery Detection

It is generally not good practice to connect a battery while the charger is running. The timer is in an unknown state and the charger could provide a large surge current into the battery for a brief time. The Figure 5 circuit keeps the charger shut down and the timer reset while a battery is not connected.

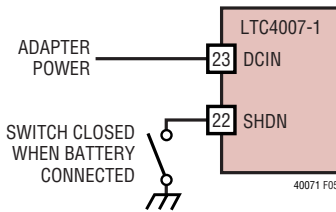

Figure 5

Charger Current Programming

The basic formula for charging current is:

$$I_{\text{CHARGE(MAX)}} = \frac{V_{\text{REF}} \cdot 3.01\text{k}\Omega / R_{\text{PROG}} - 0.035\text{V}}{R_{\text{SENSE}}}$$

$$V_{\text{REF}} = 1.19\text{V}$$

This leaves two degrees of freedom: R_{SENSE} and R_{PROG} . The 3.01k input resistors must not be altered since internal currents and voltages are trimmed for this value. Pick R_{SENSE} by setting the average voltage between C_{SP} and BAT to be close to 100mV during maximum charger current. Then R_{PROG} can be determined by solving the above equation for R_{PROG} .

$$R_{\text{PROG}} = \frac{V_{\text{REF}} \cdot 3.01\text{k}\Omega}{R_{\text{SENSE}} \cdot I_{\text{CHARGE(MAX)}} + 0.035\text{V}}$$

Table 2. Recommended R_{SNS} and R_{PROG} Resistor Values

I_{MAX} (A)	R_{SENSE} (Ω) 1%	R_{SENSE} (W)	R_{PROG} (k Ω) 1%
1.0	0.100	0.25	26.7
2.0	0.050	0.25	26.7
3.0	0.033	0.5	26.7
4.0	0.025	0.5	26.7

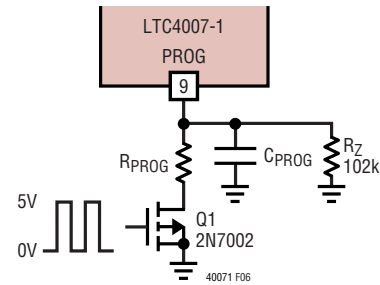

Figure 6. PWM Current Programming

Charging current can be programmed by pulse width modulating R_{PROG} with a switch Q1 to R_{PROG} at a frequency higher than a few kHz (Figure 6). C_{PROG} must be increased to reduce the ripple caused by the R_{PROG} switching. The compensation capacitor at ITH will probably need to be increased also to improve stability and prevent large overshoot currents during start-up conditions. Charging current will be proportional to the duty cycle of the switch with full current at 100% duty cycle and zero current when Q1 is off.

Maintaining C/10 Accuracy

The C/10 comparator threshold that drives the $\overline{\text{FLAG}}$ pin has a fixed threshold of approximately $V_{\text{PROG}} = 400\text{mV}$. This threshold works well when R_{PROG} is 26.7k, but will not yield a 10% charging current indication if R_{PROG} is a different value. There are situations where a standard value of R_{SENSE} will not allow the desired value of charging current when using the preferred R_{PROG} value. In these cases, where the full-scale voltage across R_{SENSE} is within $\pm 20\text{mV}$ of the 100mV full-scale target, the input resistors connected to CSP and BAT can be adjusted to provide the desired maximum programming current as well as the correct $\overline{\text{FLAG}}$ trip point.

For example, the desired max charging current is 2.5A but the best R_{SENSE} value is 0.033 Ω . In this case, the voltage across R_{SENSE} at maximum charging current is only 82.5mV, normally R_{PROG} would be 30.1k but the nominal $\overline{\text{FLAG}}$ trip point is only 5% of maximum charging current. If the input resistors are reduced by the same amount as

APPLICATIONS INFORMATION

the full-scale voltage is reduced then, $R_4 = R_5 = 2.49k$ and $R_{PROG} = 26.7k$, the maximum charging current is still 2.5A but the FLAG trip point is maintained at 10% of full scale.

There are other effects to consider. The voltage across the current comparator is scaled to obtain the same values as the 100mV sense voltage target, but the input referred sense voltage is reduced, causing some careful consideration of the ripple current. Input referred maximum comparator threshold is 117mV, which is the same ratio of 1.4x the DC target. Input referred I_{REV} threshold is scaled back to $-24mV$. The current at which the switcher starts will be reduced as well so there is some risk of boost activity. These concerns can be addressed by using a slightly larger inductor to compensate for the reduction of tolerance to ripple current.

Charger Voltage Programming

Pins CHEM and C3C4 are used to program the charger final output voltage. The CHEM pin programs Li-Ion battery chemistry for 4.1V/cell (low) or 4.2V/cell (high). The C3C4 pin selects either 3 series cells (low) or 4 series cells (high). It is recommended that these pins be shorted to ground (logic low) or left open (logic high) to effect the desired logic level. Use open-collector or open-drain outputs when interfacing to the CHEM and C3C4 pins from a logic control circuit.

Table 3. Charger Voltage Programming

V_{FINAL} (V)	C3C4	CHEM
12.3	LOW	LOW
12.6	LOW	HIGH
16.4	HIGH	LOW
16.8	HIGH	HIGH

Setting the Timer Resistor

The charger termination timer is designed for a range of 1 hour to 3 hour with a $\pm 15\%$ uncertainty. The timer is programmed by the resistor R_{RT} using the following equation:

$$t_{TIMER} = 10 \cdot 2^{27} \cdot R_{RT} \cdot 17.5pF \text{ (seconds)}$$

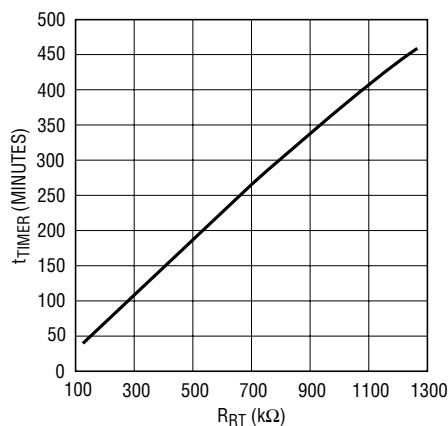

Figure 7. t_{TIMER} vs R_{RT}

It is important to keep the parasitic capacitance on the R_T pin to a minimum. The trace connecting R_T to R_{RT} should be as short as possible.

Soft-Start

The LTC4007-1 is soft started by the 0.12 μ F capacitor on the I_{TH} pin. On start-up, I_{TH} pin voltage will rise quickly to 0.5V, then ramp up at a rate set by the internal 40 μ A pull-up current and the external capacitor. Battery charging current starts ramping up when I_{TH} voltage reaches 0.8V and full current is achieved with I_{TH} at 2V. With a 0.12 μ F capacitor, time to reach full charge current is about 2ms and it is assumed that input voltage to the charger will reach full value in less than 2ms. The capacitor can be increased up to 1 μ F if longer input start-up times are needed.

Input and Output Capacitors

The input capacitor (C2) is assumed to absorb all input switching ripple current in the converter, so it must have adequate ripple current rating. Worst-case RMS ripple current will be equal to one half of output charging current. Actual capacitance value is not critical. Solid tantalum low ESR capacitors have high ripple current rating in a relatively small surface mount package, *but caution must be*

APPLICATIONS INFORMATION

used when tantalum capacitors are used for input or output bypass. High input surge currents can be created when the adapter is hot-plugged to the charger or when a battery is connected to the charger. Solid tantalum capacitors have a known failure mechanism when subjected to very high turn-on surge currents. Only Kemet T495 series of “Surge Robust” low ESR tantalums are rated for high surge conditions such as battery to ground.

The relatively high ESR of an aluminum electrolytic for C1, located at the AC adapter input terminal, is helpful in reducing ringing during the hot-plug event. Refer to AN88 for more information.

Highest possible voltage rating on the capacitor will minimize problems. Consult with the manufacturer before use. Alternatives include new high capacity ceramic (at least 20 μ F) from Tokin, United Chemi-Con/Marcon, et al. Other alternative capacitors include OS-CON capacitors from Sanyo.

The output capacitor (C3) is also assumed to absorb output switching current ripple. The general formula for capacitor current is:

$$I_{RMS} = \frac{0.29(V_{BAT}) \left(1 - \frac{V_{BAT}}{V_{DCIN}}\right)}{(L1)(f)}$$

For example:

$$V_{DCIN} = 19V, V_{BAT} = 12.6V, L1 = 10\mu H, \text{ and } f = 300kHz, I_{RMS} = 0.41A.$$

EMI considerations usually make it desirable to minimize ripple current in the battery leads, and beads or inductors may be added to increase battery impedance at the 300kHz switching frequency. Switching ripple current splits between the battery and the output capacitor depending on the ESR of the output capacitor and the battery impedance. If the ESR of C3 is 0.2 Ω and the battery impedance

is raised to 4 Ω with a bead or inductor, only 5% of the current ripple will flow in the battery.

Inductor Selection

Higher operating frequencies allow the use of smaller inductor and capacitor values. A higher frequency generally results in lower efficiency because of MOSFET gate charge losses. In addition, the effect of inductor value on ripple current and low current operation must also be considered. The inductor ripple current ΔI_L decreases with higher frequency and increases with higher V_{IN} .

$$\Delta I_L = \frac{1}{(f)(L)} V_{OUT} \left(1 - \frac{V_{OUT}}{V_{IN}}\right)$$

Accepting larger values of ΔI_L allows the use of low inductances, but results in higher output voltage ripple and greater core losses. A reasonable starting point for setting ripple current is $\Delta I_L = 0.4(I_{MAX})$. In no case should ΔI_L exceed 0.6(I_{MAX}) due to limits imposed by I_{REV} and CA1. Remember the maximum ΔI_L occurs at the maximum input voltage. In practice 10 μ H is the lowest value recommended for use.

Lower charger currents generally call for larger inductor values. Use Table 4 as a guide for selecting the correct inductor value for your application.

Table 4

MAX AVERAGE CURRENT (A)	INPUT VOLTAGE (V)	MINIMUM INDUCTOR VALUE (μ H)
1	≤ 20	40 \pm 20%
1	> 20	56 \pm 20%
2	≤ 20	20 \pm 20%
2	> 20	30 \pm 20%
3	≤ 20	15 \pm 20%
3	> 20	20 \pm 20%
4	≤ 20	10 \pm 20%
4	> 20	15 \pm 20%

APPLICATIONS INFORMATION

Charger Switching Power MOSFET and Diode Selection

Two external power MOSFETs must be selected for use with the charger: a P-channel MOSFET for the top (main) switch and an N-channel MOSFET for the bottom (synchronous) switch.

The peak-to-peak gate drive levels are set internally. This voltage is typically 6V. Consequently, logic-level threshold MOSFETs must be used. Pay close attention to the BV_{DSS} specification for the MOSFETs as well; many of the logic level MOSFETs are limited to 30V or less.

Selection criteria for the power MOSFETs include the “ON” resistance $R_{DS(ON)}$, total gate capacitance Q_G , reverse transfer capacitance C_{RSS} , input voltage and maximum output current. The charger is operating in continuous mode at moderate to high currents so the duty cycles for the top and bottom MOSFETs are given by:

$$\text{Main Switch Duty Cycle} = V_{OUT}/V_{IN}$$

$$\text{Synchronous Switch Duty Cycle} = (V_{IN} - V_{OUT})/V_{IN}$$

The MOSFET power dissipations at maximum output current are given by:

$$P_{MAIN} = V_{OUT}/V_{IN}(I_{MAX})^2(1 + \delta\Delta T)R_{DS(ON)} + k(V_{IN})^2(I_{MAX})(C_{RSS})(f_{OSC})$$

$$P_{SYNC} = (V_{IN} - V_{OUT})/V_{IN}(I_{MAX})^2(1 + \delta\Delta T)R_{DS(ON)}$$

Where $\delta\Delta T$ is the temperature dependency of $R_{DS(ON)}$ and k is a constant inversely related to the gate drive current. Both MOSFETs have I^2R losses while the P_{MAIN} equation includes an additional term for transition losses, which are highest at high input voltages. For $V_{IN} < 20V$ the high current efficiency generally improves with larger MOSFETs, while for $V_{IN} > 20V$ the transition losses rapidly increase to the point that the use of a higher $R_{DS(ON)}$ device with lower C_{RSS} actually provides higher efficiency. The synchronous MOSFET losses are greatest at high input voltage or during a short circuit when the duty cycle in this

switch is nearly 100%. The term $(1 + \delta\Delta T)$ is generally given for a MOSFET in the form of a normalized $R_{DS(ON)}$ vs temperature curve, but $\delta = 0.005/^\circ C$ can be used as an approximation for low voltage MOSFETs. $C_{RSS} = Q_{GD}/\Delta V_{DS}$ is usually specified in the MOSFET characteristics. The constant $k = 2$ can be used to estimate the contributions of the two terms in the main switch dissipation equation.

If the charger is to operate in low dropout mode or with a high duty cycle greater than 85%, then the topside P-channel efficiency generally improves with a larger MOSFET. Using asymmetrical MOSFETs may achieve cost savings or efficiency gains.

The Schottky diode D1, shown in the Typical Application on the back page, conducts during the dead-time between the conduction of the two power MOSFETs. This prevents the body diode of the bottom MOSFET from turning on and storing charge during the dead-time, which could cost as much as 1% in efficiency. A 1A Schottky is generally a good size for 4A regulators due to the relatively small average current. Larger diodes can result in additional transition losses due to their larger junction capacitance.

The diode may be omitted if the efficiency loss can be tolerated.

Calculating IC Power Dissipation

The power dissipation of the LTC4007-1 is dependent upon the gate charge of the top and bottom MOSFETs (Q_{G1} & Q_{G2} respectively) The gate charge is determined from the manufacturer’s data sheet and is dependent upon both the gate voltage swing and the drain voltage swing of the MOSFET. Use 6V for the gate voltage swing and V_{DCIN} for the drain voltage swing.

$$PD = V_{DCIN} \cdot (f_{OSC} (Q_{G1} + Q_{G2}) + I_Q)$$

Example:

$$V_{DCIN} = 19V, f_{OSC} = 345kHz, Q_{G1} = Q_{G2} = 15nC, I_Q = 5mA$$

$$PD = 292mW$$

APPLICATIONS INFORMATION

Adapter Limiting

An important feature of the LTC4007-1 is the ability to automatically adjust charging current to a level which avoids overloading the wall adapter. This allows the product to operate at the same time that batteries are being charged without complex load management algorithms. Additionally, batteries will automatically be charged at the maximum possible rate of which the adapter is capable.

This feature is created by sensing total adapter output current and adjusting charging current downward if a preset adapter current limit is exceeded. True analog control is used, with closed-loop feedback ensuring that adapter load current remains within limits. Amplifier CL1 in Figure 8 senses the voltage across R_{CL} , connected between the CLP and CLN pins. When this voltage exceeds 100mV, the amplifier will override programmed charging current to limit adapter current to $100\text{mV}/R_{CL}$. A lowpass filter formed by $5\text{k}\Omega$ and 15nF is required to eliminate switching noise. If the current limit is not used, CLP should be connected to CLN.

Note that the $\overline{I_{CL}}$ pin will be asserted when the voltage across R_{CL} is 93mV, before the adapter limit regulation threshold.

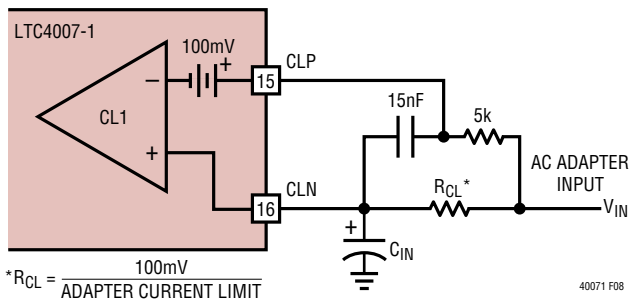

Figure 8. Adapter Current Limiting

Setting Input Current Limit

To set the input current limit, you need to know the minimum wall adapter current rating. Subtract 7% for the

input current limit tolerance and use that current to determine the resistor value.

$$R_{CL} = 100\text{mV}/I_{LIM}$$

$$I_{LIM} = \text{Adapter Min Current} - (\text{Adapter Min Current} \cdot 7\%)$$

Table 5. Common R_{CL} Resistor Values

ADAPTER RATING (A)	R_{CL} VALUE* (Ω) 1%	R_{CL} POWER DISSIPATION (W)	R_{CL} POWER RATING (W)
1.5	0.06	0.135	0.25
1.8	0.05	0.162	0.25
2	0.045	0.18	0.25
2.3	0.039	0.206	0.25
2.5	0.036	0.225	0.5
2.7	0.033	0.241	0.5
3	0.03	0.27	0.5

* Values shown above are rounded to nearest standard value.

As is often the case, the wall adapter will usually have at least a +10% current limit margin and many times one can simply set the adapter current limit value to the actual adapter rating (see Table 5).

Designing the Thermistor Network

There are several networks that will yield the desired function of voltage vs temperature needed for proper operation of the thermistor. The simplest of these is the voltage divider shown in Figure 9. Unfortunately, since the HIGH/LOW comparator thresholds are fixed internally, there is only one thermistor type that can be used in this network; the thermistor must have a HIGH/LOW resistance ratio of 1:7. If this happy circumstance is true for you, then simply set $R_9 = R_{TH(Low)}$.

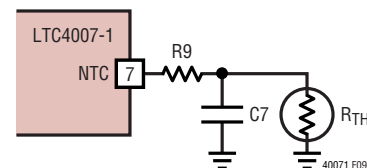

Figure 9. Voltage Divider Thermistor Network

APPLICATIONS INFORMATION

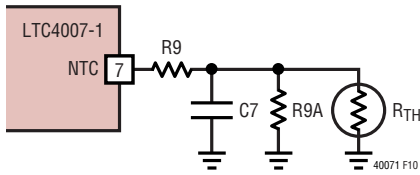

Figure 10. General Thermistor Network

If you are using a thermistor that doesn't have a 1:7 HIGH/LOW ratio, or you wish to set the HIGH/LOW limits to different temperatures, then the more generic network in Figure 10 should work.

Once the thermistor, R_{TH} , has been selected and the thermistor value is known at the temperature limits, then resistors R_9 and R_{9A} are given by:

For NTC thermistors:

$$R_9 = 6 R_{TH(Low)} \cdot R_{TH(High)} / (R_{TH(Low)} - R_{TH(High)})$$

$$R_{9A} = 6 R_{TH(Low)} \cdot R_{TH(High)} / (R_{TH(Low)} - 7 \cdot R_{TH(High)})$$

$$\text{Where } R_{TH(Low)} > 7 \cdot R_{TH(High)}$$

For PTC thermistors:

$$R_9 = 6 R_{TH(Low)} \cdot R_{TH(High)} / (R_{TH(High)} - R_{TH(Low)})$$

$$R_{9A} = 6 R_{TH(Low)} \cdot R_{TH(High)} / (R_{TH(High)} - 7 \cdot R_{TH(Low)})$$

$$\text{Where } R_{TH(High)} > 7 \cdot R_{TH(Low)}$$

Example #1: 10k Ω NTC with custom limits

$$T_{LOW} = 0^\circ\text{C}, T_{HIGH} = 50^\circ\text{C}$$

$$R_{TH} = 10\text{k at } 25^\circ\text{C},$$

$$R_{TH(Low)} = 32.582\text{k at } 0^\circ\text{C}$$

$$R_{TH(High)} = 3.635\text{k at } 50^\circ\text{C}$$

$$R_9 = 24.55\text{k} \rightarrow 24.3\text{k (nearest 1\% value)}$$

$$R_{9A} = 99.6\text{k} \rightarrow 100\text{k (nearest 1\% value)}$$

Example #2: 100k Ω NTC

$$T_{LOW} = 5^\circ\text{C}, T_{HIGH} = 50^\circ\text{C}$$

$$R_{TH} = 100\text{k at } 25^\circ\text{C},$$

$$R_{TH(Low)} = 272.05\text{k at } 5^\circ\text{C}$$

$$R_{TH(High)} = 33.195\text{k at } 50^\circ\text{C}$$

$$R_9 = 226.9\text{k} \rightarrow 226\text{k (nearest 1\% value)}$$

$$R_{9A} = 1.365\text{M} \rightarrow 1.37\text{M (nearest 1\% value)}$$

Example #3: 22k Ω PTC

$$T_{LOW} = 0^\circ\text{C}, T_{HIGH} = 50^\circ\text{C}$$

$$R_{TH} = 22\text{k at } 25^\circ\text{C},$$

$$R_{TH(Low)} = 6.53\text{k at } 0^\circ\text{C}$$

$$R_{TH(High)} = 61.4\text{k at } 50^\circ\text{C}$$

$$R_9 = 43.9\text{k} \rightarrow 44.2\text{k (nearest 1\% value)}$$

$$R_{9A} = 154\text{k}$$

Sizing the Thermistor Hold Capacitor

During the hold interval, C_7 must hold the voltage across the thermistor relatively constant to avoid false readings. A reasonable amount of ripple on NTC during the hold interval is about 10mV to 15mV. Therefore, the value of C_7 is given by:

$$C_7 = t_{HOLD} / (R_9 / 7 \cdot -\ln(1 - 8 \cdot 15\text{mV} / 4.5\text{V}))$$

$$= 10 \cdot R_{RT} \cdot 17.5\text{pF} / (R_9 / 7 \cdot -\ln(1 - 8 \cdot 15\text{mV} / 4.5\text{V}))$$

Example:

$$R_9 = 24.3\text{k}$$

$$R_{RT} = 309\text{k} (\sim 2 \text{ hour timer})$$

$$C_7 = 0.57\mu\text{F} \rightarrow 0.56\mu\text{F (nearest value)}$$

APPLICATIONS INFORMATION

Disabling the Thermistor Function

If the thermistor is not needed, connecting a resistor between DCIN and NTC will disable it. The resistor should be sized to provide at least $10\mu\text{A}$ with the minimum voltage applied to DCIN and 10V at NTC. Do not exceed $30\mu\text{A}$. Generally, a 301k resistor will work for DCIN less than 15V. A 499k resistor is recommended for DCIN between 15V and 24V.

Conditioning Depleted Batteries

Severely depleted batteries, with less than 3.25V/cell, should be conditioned with a trickle charge to prevent possible damage. This trickle charge is typically 10% of the 1C rate of the battery. The LTC4007-1 can automatically trickle charge depleted batteries using the circuit in Figure 11. If the battery voltage is less than 3.25V/cell (3.173V/cell if CHEM is low) then the $\overline{\text{LOBAT}}$ indicator will be low and Q4 is off. This programs the charging current with $R_{\text{PROG}} = R6 + R14$. Charging current is approximately 300mA. When the cell voltage becomes greater than 3.25V the $\overline{\text{LOBAT}}$ indicator goes high, Q4 shorts out R13, then $R_{\text{PROG}} = R6$. Charging current is then equal to 3A.

PCB Layout Considerations

For maximum efficiency, the switch node rise and fall times should be minimized. To prevent magnetic and electrical field radiation and high frequency resonant problems, proper layout of the components connected to the IC is essential. (See Figure 12.) Here is a PCB layout priority list for proper layout. Layout the PCB using this specific order.

General Rules

1. Input capacitors need to be placed as close as possible to switching FET's supply and ground connections. Shortest copper trace connections possible. These parts must be on the same layer of copper. Vias must not be used to make this connection.
2. The control IC needs to be close to the switching FET's gate terminals. Keep the gate drive signals short for a clean FET drive. This includes IC supply pins that connect to the switching FET source pins. The IC can be placed on the opposite side of the PCB relative to above.
3. Place inductor input as close as possible to switching FET's output connection. Minimize the surface area of this trace. Make the trace width the minimum amount needed to support current—no copper fills or pours. Avoid running the connection using multiple layers in parallel. Minimize capacitance from this node to any other trace or plane.
4. Place the output current sense resistor right next to the inductor output but oriented such that the IC's current sense feedback traces going to resistor are not long. The feedback traces need to be routed together as a single pair on the same layer at any given time with smallest trace spacing possible. Locate any filter component on these traces next to the IC and not at the sense resistor location.
5. Place output capacitors next to the sense resistor output and ground.
6. Output capacitor ground connections need to feed into same copper that connects to the input capacitor ground before tying back into system ground.

APPLICATIONS INFORMATION

General Rules (Continued)

7. Connection of switching ground to system ground or internal ground plane should be single point. If the system has an internal system ground plane, a good way to do this is to cluster vias into a single star point to make the connection.
8. Route analog ground as a trace tied back to IC ground (analog ground pin if present) before connecting to any other ground. Avoid using the system ground plane. CAD trick: make analog ground a separate ground net and use a 0Ω resistor to tie analog ground to system ground.
9. A good rule of thumb for via count for a given high current path is to use 0.5A per via. Be consistent.
10. If possible, place all the parts listed above on the same PCB layer.
11. Copper fills or pours are good for all power connections except as noted above in Rule 3. You can also use copper planes on multiple layers in parallel too—this helps with thermal management and lower trace inductance improving EMI performance further.
12. For best current programming accuracy provide a Kelvin connection from R_{SENSE} to CSP and BAT. See Figure 12 as an example.

It is important to keep the parasitic capacitance on the R_T , CSP and BAT pins to a minimum. The traces connecting these pins to their respective resistors should be as short as possible.

APPLICATIONS INFORMATION

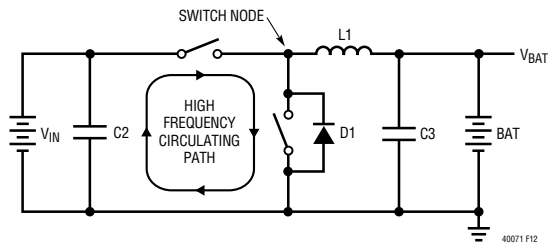

Figure 12. High Speed Switching Path

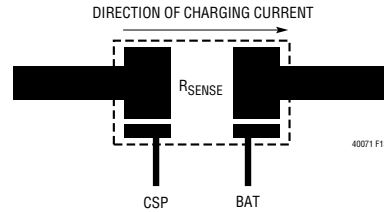
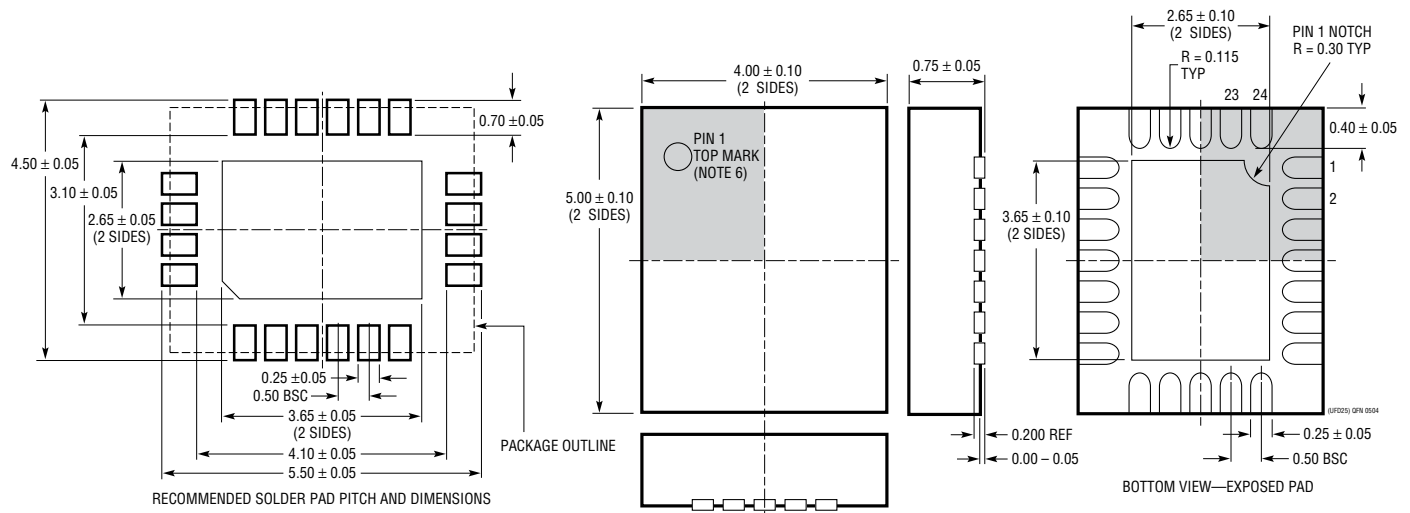

Figure 13. Kelvin Sensing of Charging Current

PACKAGE DESCRIPTION

UFD Package 24-Lead Plastic QFN (4mm × 5mm) (Reference LTC DWG # 05-08-1696)



- NOTE:
1. DRAWING PROPOSED TO BE MADE A JEDEC PACKAGE OUTLINE MO-220 VARIATION (WXXX-X).
 2. DRAWING NOT TO SCALE
 3. ALL DIMENSIONS ARE IN MILLIMETERS

4. DIMENSIONS OF EXPOSED PAD ON BOTTOM OF PACKAGE DO NOT INCLUDE MOLD FLASH. MOLD FLASH, IF PRESENT, SHALL NOT EXCEED 0.15mm ON ANY SIDE
5. EXPOSED PAD SHALL BE SOLDER PLATED
6. SHADED AREA IS ONLY A REFERENCE FOR PIN 1 LOCATION ON THE TOP AND BOTTOM OF PACKAGE

TYPICAL APPLICATION

12.6V, 4A Li-Ion Battery Charger

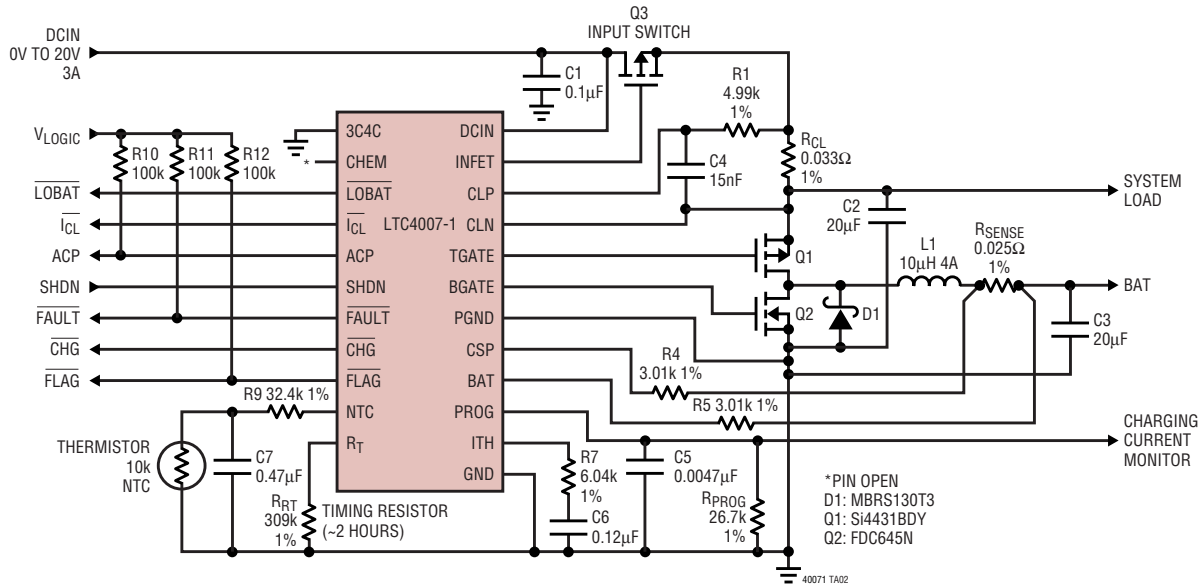

RELATED PARTS

PART NUMBER	DESCRIPTION	COMMENTS
LT [®] 1511	Constant-Current/Constant-Voltage 3A Battery Charger with Input Current Limiting	High Efficiency Current Mode PWM with 4A Internal Switch
LT1513	SEPIC Constant- or Programmable-Current/Constant-Voltage Battery Charger	Charger Input Voltage May Be Higher, Equal to or Lower Than Battery Voltage; Charges Any Number of Cells Up to 20V, 500kHz Switching Frequency
LT1571	1.5A Switching Charger	1- or 2-Cell Li-Ion, 500kHz or 200kHz Switching Frequency, Termination Flag
LTC1628-PG	2-Phase, Dual Synchronous Step-Down Controller	Minimizes C_{IN} and C_{OUT} , Power Good Output, $3.5V \leq V_{IN} \leq 36V$
LTC1709	2-Phase, Dual Synchronous Step-Down Controller with VID	Up to 42A Output, Minimum C_{IN} and C_{OUT} , Uses Smallest Components for Intel and AMD Processors
LT1769	2A Switching Battery Charger	Constant-Current/Constant-Voltage Switching Regulator, Input Current Limiting Maximizes Charge Current
LTC1778	Wide Operating Range, No R_{SENSE} Synchronous Step-Down Controller	2% to 90% Duty Cycle at 200kHz, Stable with Ceramic C_{OUT}
LTC1960	Dual Battery Charger/Selector with SPI Interface	Simultaneous Charge or Discharge of Two Batteries, DAC Programmable Current and Voltage, Input Current Limiting Maximizes Charge Current
LTC3711	No R_{SENSE} [™] Synchronous Step-Down Controller with VID	$3.5V \leq V_{IN} \leq 36V$, $0.925V \leq V_{OUT} \leq 2V$, for Transmeta, AMD and Intel Mobile Processors
LTC4006	Small, High Efficiency, Fixed Voltage, Lithium-Ion Battery Charger	Constant-Current/Constant-Voltage Switching Regulator with Termination Timer, AC Adapter Current Limit and Thermistor Sensor in a Small 16-Pin Package
LTC4007	4A High Efficiency, Standalone Li-Ion Battery Charger	Complete Charger for 3- or 4-Cell Li-Ion Batteries, AC Adapter Current Limit and Thermistor Sensor, 16-Pin Narrow SSOP Package
LTC4008	High Efficiency, Programmable Voltage/Current Battery Charger	Constant-Current/Constant-Voltage Switching Regulator, Resistor Voltage/Current Programming, AC Adapter Current Limit and Thermistor Sensor
LTC4100	Smart Battery Charger Controller	100% Compliant SMBus 1.1 Support, V_{IN} : 6.4V to 26V, $V_{DROPOUT} = 0.5V$, High Efficiency Synchronous Buck Charger

No R_{SENSE} is a trademark of Linear Technology Corporation.