

Standalone USB Li-Ion/Polymer Battery Charger in 2mm × 2mm DFN

FEATURES

- Full-Featured Standalone USB Li-Ion/Polymer Battery Charger
- 100mA to 950mA Programmable Charge Current
- C/10 Charge Current Detection Output
- Internal Safety Timer Termination
- NTC Thermistor Input for Temperature Qualified Charging
- Preset 4.2V Float Voltage with 0.5% Accuracy
- Constant-Current/Constant-Voltage Operation with Thermal Feedback
- Charge Current Monitor Output for Gas Gauging
- Automatic Recharge
- Bad-Battery Detection
- 8.5µA Input Supply Current in Suspend Mode
- Tiny 8-Lead (2mm × 2mm) DFN Package

APPLICATIONS

- PDAs
- Media Players
- Cellular Phones
- Other Portable Electronics

DESCRIPTION

The LTC[®]4095 is a complete constant-current/constant-voltage linear charger for single-cell lithium-ion/polymer batteries. Its small 2mm × 2mm DFN package and low external component count make the LTC4095 especially well-suited for portable USB power applications.

Up to 950mA of charge current may be programmed via a single resistor from the PROG pin to ground. The HPWR pin allows the charge current to be set at 20% or 100% of its full-scale programmed value. An internal safety timer terminates charge current. The final float voltage is preset to 4.2V and held to a tight 0.5% tolerance. Also featured is an NTC thermistor input to monitor battery temperature while charging, a C/10 current detection output, automatic recharge, bad-battery detection and low-battery trickle charge. A thermal feedback loop regulates the charge current to limit the die temperature during high power operation or high ambient thermal conditions.

The LTC4095 is available in a tiny, low profile (0.75mm) 8-lead 2mm × 2mm DFN package.

LT, **LT**, **LTC** and **LTM** are registered trademarks of Linear Technology Corporation. All other trademarks are the property of their respective owners. Protected by U.S. Patents, including 6522118, 6570372, 6700364.

TYPICAL APPLICATION

500mA Single-Cell Li-Ion Charger

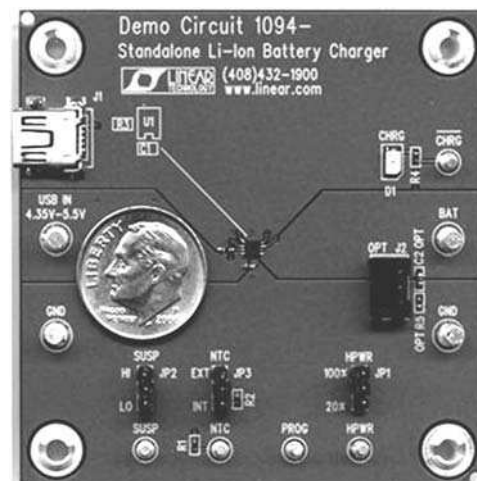
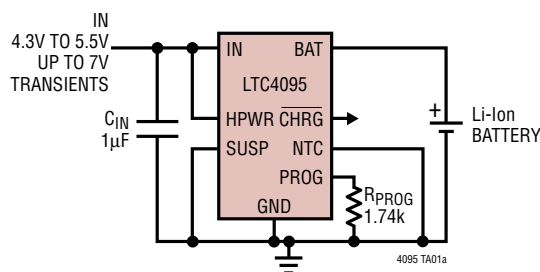

ABSOLUTE MAXIMUM RATINGS

(Notes 1, 2, 3)

Input Supply Voltage (IN)

$t < 1\text{ms}$ and Duty Cycle $< 1\%$ -0.3V to 7V

Steady State -0.3V to 6V

BAT, SUSP, CHRG Voltage -0.3V to 6V

PROG, NTC, HPWR

Voltage -0.3V to Max (IN, BAT) + 0.3V

I_{BAT} 1A

I_{PROG} 1.25mA

I_{CHRG} 50mA

Junction Temperature 125°C

Operating Temperature Range -40°C to 85°C

Storage Temperature Range -65°C to 125°C

PACKAGE/ORDER INFORMATION

DC PACKAGE 8-LEAD (2mm x 2mm) PLASTIC DFN $T_{\text{JMAX}} = 125^\circ\text{C}$, $\theta_{\text{JA}} = 60^\circ\text{C/W}$ EXPOSED PAD (PIN 9) IS GND, MUST BE SOLDERED TO PCB	
ORDER PART NUMBER	DC PART MARKING
LTC4095EDC	LCLG
Order Options Tape and Reel: Add #TR Lead Free: Add #PBF Lead Free Tape and Reel: Add #TRPBF Lead Free Part Marking: http://www.linear.com/leadfree/	

Consult LTC Marketing for parts specified with wider operating temperature ranges.

ELECTRICAL CHARACTERISTICS

The ● denotes the specifications which apply over the full operating temperature range, otherwise specifications are at $T_A = 25^\circ\text{C}$. IN = HPWR = 5V, BAT = 3.8V, NTC = SUSP = 0V, $R_{\text{PROG}} = 1.74\text{k}$ unless otherwise specified.

SYMBOL	PARAMETER	CONDITIONS	MIN	TYP	MAX	UNITS
Battery Charger						
IN	Input Supply Voltage		● 4.3		5.5	V
I_{IN}	Battery Charger Quiescent Current (Note 4)	Standby Mode; Charger Terminated Suspend Mode; SUSP = 5V		200 8.5	400 17	μA μA
V_{FLOAT}	BAT Regulated Output Voltage	$0^\circ\text{C} \leq T_A \leq 85^\circ\text{C}$	4.179 4.165	4.200 4.200	4.221 4.235	V V
I_{CHG}	Constant-Current Mode Charge Current	HPWR = 5V HPWR = 0V	● 440 84	460 92	500 100	mA mA
I_{BAT}	Battery Drain Current	Standby Mode; Charger Terminated Shutdown Mode; IN $< V_{\text{UVLO}}$, BAT = 4.2V Suspend Mode; SUSP = 5V, BAT = 4.2V		-3.5 -2.0 -1.3	-7 -4 -3	μA μA μA
V_{UVLO}	Undervoltage Lockout Threshold	BAT = 3.5V, IN Rising	3.875	4.0	4.125	V
ΔV_{UVLO}	Undervoltage Lockout Hysteresis	BAT = 3.5V		200		mV
V_{DUVLO}	Differential Undervoltage Lockout Threshold	BAT = 4.05V, (IN – BAT), IN Falling	25	40	60	mV
ΔV_{DUVLO}	Differential Undervoltage Lockout Hysteresis	BAT = 4.05V		125		mV
PROG	PROG Pin Servo Voltage	HPWR = 5V HPWR = 0V BAT $< V_{\text{TRKL}}$		1.000 0.200 0.100		V V V
h_{PROG}	Ratio of I_{BAT} to PROG Pin Current			800		mA/mA
I_{TRKL}	Trickle Charge Current	BAT $< V_{\text{TRKL}}$	37	46	55	mA
V_{TRKL}	Trickle Charge Threshold Voltage	BAT Rising	2.8	2.9	3.0	V
ΔV_{TRKL}	Trickle Charge Hysteresis Voltage			100		mV
ΔV_{RECHRG}	Recharge Battery Threshold Voltage	Threshold Voltage Relative to V_{FLOAT}	-75	-95	-115	mV

4095fa

ELECTRICAL CHARACTERISTICS

The ● denotes the specifications which apply over the full operating temperature range, otherwise specifications are at $T_A = 25^\circ\text{C}$. IN = HPWR = 5V, BAT = 3.8V, NTC = SUSP = 0V, R_{PROG} = 1.74k unless otherwise specified.

SYMBOL	PARAMETER	CONDITIONS	MIN	TYP	MAX	UNITS
t _{RECHRG}	Recharge Comparator Filter Time	BAT Falling		1.7		ms
t _{TERM}	Safety Timer Termination Period	BAT = V _{FLOAT}	3.5	4	4.5	Hour
t _{BADBAT}	Bad-Battery Termination Time	BAT < V _{TRKL}	0.4375	0.5	0.5625	Hour
h _{C/10}	End of Charge Indication Current Level	(Note 5)	0.09	0.1	0.11	mA/mA
t _{C/10}	End of Charge Comparator Filter Time	I _{BAT} Falling		2.2		ms
R _{ON_CHG}	Battery Charger Power FET On-Resistance (Between IN and BAT)	I _{BAT} = 200mA		500		mΩ
T _{LIM}	Junction Temperature in Constant Temperature			115		°C

NTC

V _{COLD}	Cold Temperature Fault Threshold Voltage	Rising NTC Voltage Hysteresis	0.750 • IN	0.765 • IN 0.016 • IN	0.780 • IN	V V
V _{HOT}	Hot Temperature Fault Threshold Voltage	Falling NTC Voltage Hysteresis	0.334 • IN	0.349 • IN 0.016 • IN	0.364 • IN	V V
V _{DIS}	NTC Disable Threshold Voltage	Falling NTC Voltage Hysteresis	● 0.007 • IN	0.017 • IN 0.010 • IN	0.027 • IN	mV mV
I _{NTC}	NTC Leakage Current	NTC = IN = 5V	-1	0	1	μA

Logic (HPWR, SUSP, CHRG)

V _{IL}	Input Low Voltage	HPWR, SUSP Pins			0.4	V
V _{IH}	Input High Voltage	HPWR, SUSP Pins	1.2			V
R _{DN}	Logic Pin Pull-Down Resistance	HPWR, SUSP Pins	● 1.9	3.6	6.3	MΩ
CHRG	CHRG Pin Output Low Voltage	I _{CHRG} = 5mA		100	250	mV
I _{CHRG}	CHRG Pin Input Current	BAT = 4.5V, CHRG = 5V		0	1	μA

Note 1: Stresses beyond those listed under Absolute Maximum Ratings may cause permanent damage to the device. Exposure to any Absolute Maximum Rating condition for extended periods may affect device reliability and lifetime.

Note 2: The LTC4095 is guaranteed to meet performance specifications from 0°C to 85°C. Specifications over the -40°C to 85°C operating temperature range are assured by design, characterization and correlation with statistical process controls.

Note 3: This IC includes overtemperature protection that is intended to protect the device during momentary overload conditions. Junction temperature will exceed 125°C when overtemperature protection is active. Continuous operation above the specified maximum operating junction temperature may impair device reliability.

Note 4: IN supply current does not include current through the PROG pin or any current delivered to the battery through the BAT pin. Total input current is equal to this specification plus 1.00125 • I_{BAT} where I_{BAT} is the charge current.

Note 5: h_{C/10} is expressed as a fraction of measured full charge current with indicated PROG resistor.

TYPICAL PERFORMANCE CHARACTERISTICS $T_A = 25^\circ\text{C}$, unless otherwise noted.

**Battery Regulation (Float)
Voltage vs Battery Charge Current**

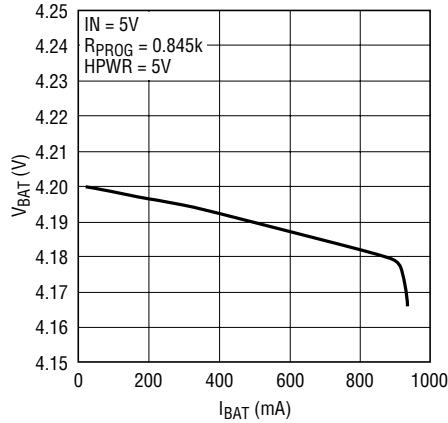

4095 G01

**Battery Regulation (Float)
Voltage vs Temperature**

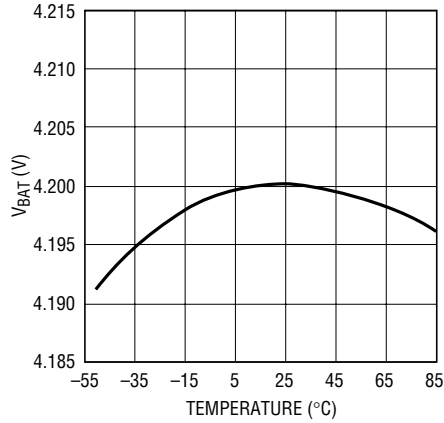

4095 G02

**Charge Current vs Supply Voltage
(Constant Current Mode)**

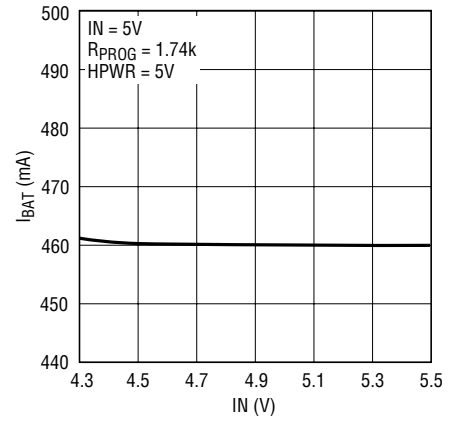

4095 G03

Charge Current vs Battery Voltage

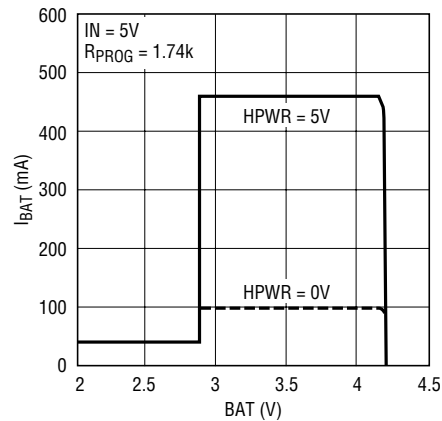

2400 G31

**Charge Current vs Ambient
Temperature with Thermal
Regulation**

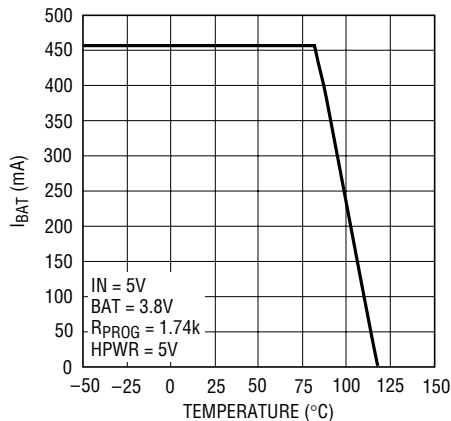

4095 G05

**Complete Charge Cycle
(2400mAh Battery)**

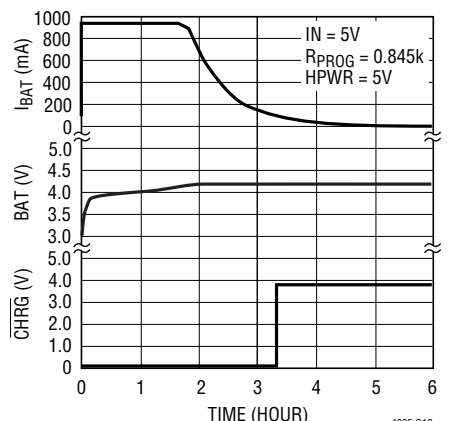

4095 G18

**PROG Pin Voltage vs Charge
Current**

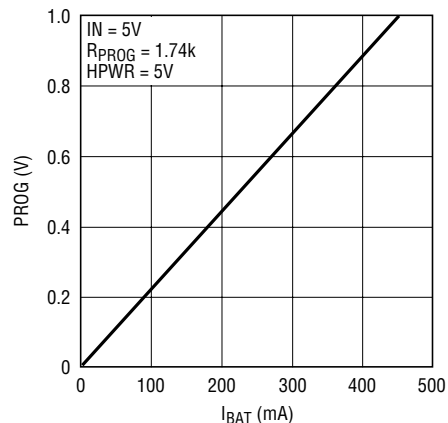

4095 G06

**PROG Pin Voltage vs PROG Pin
Resistance (Constant Current Mode)**

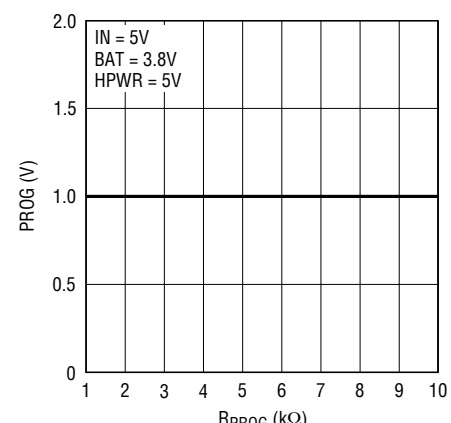

4095 G07

**Power FET On-Resistance vs
Temperature**

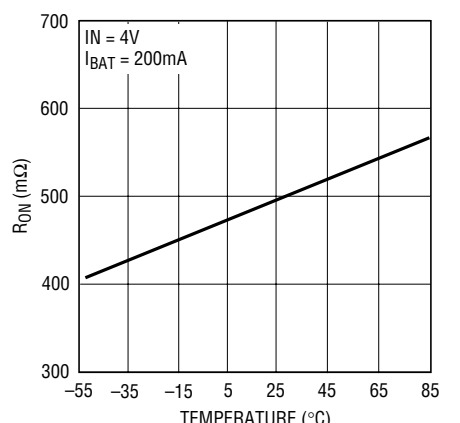

4095 G08
4095fa

TYPICAL PERFORMANCE CHARACTERISTICS $T_A = 25^\circ\text{C}$, unless otherwise noted.

Recharge Threshold vs Temperature

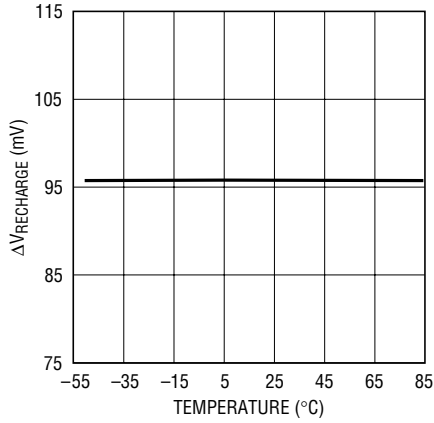

4095 G09

Undervoltage Lockout Threshold vs Temperature

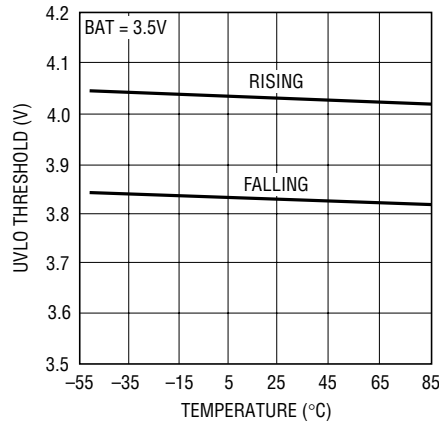

4095 G10

SUSP/HPWR Pins Rising Threshold Voltage vs Temperature

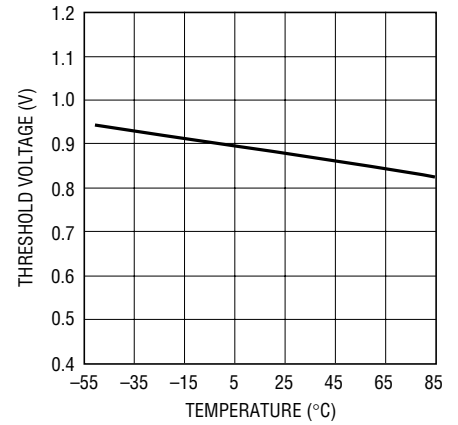

4095 G11

Supply Currents in Suspend vs Temperature

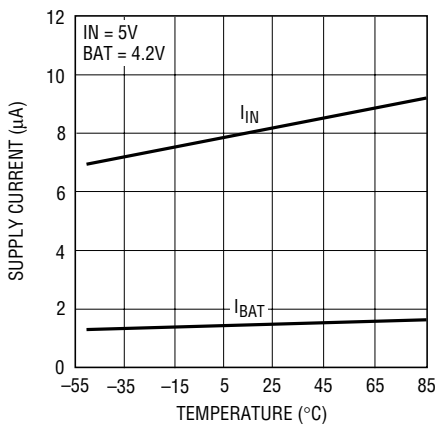

4095 G12

Battery Drain Current in UVLO vs Temperature

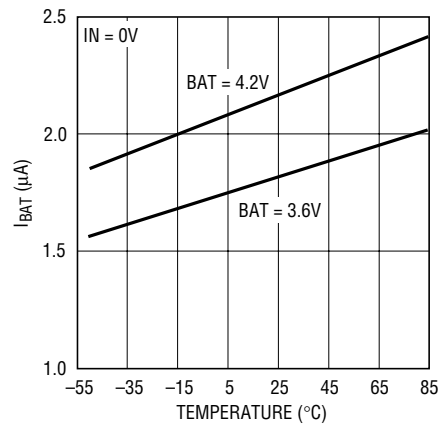

4095 G13

CHRG Pin I-V Curve

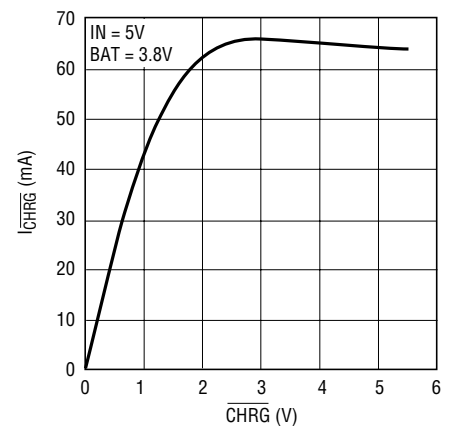

4095 G14

CHRG Pin Output Low Voltage vs Temperature

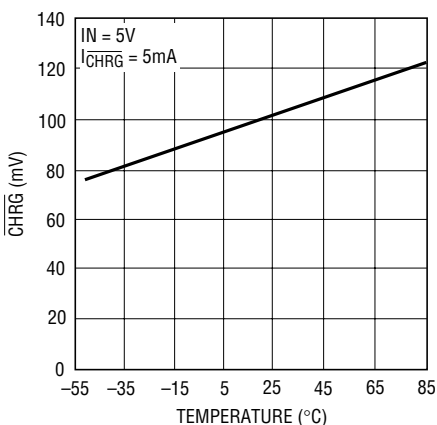

4095 G15

Timer Period Accuracy vs Temperature

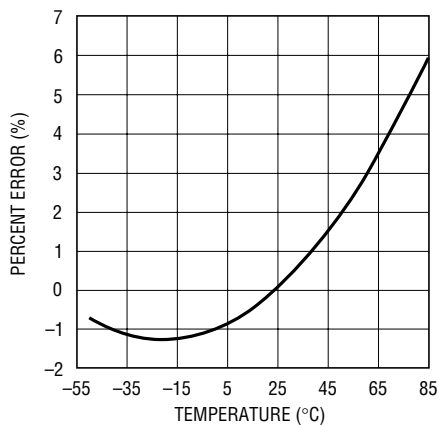

4095 G16

Timer Period Accuracy vs Supply Voltage

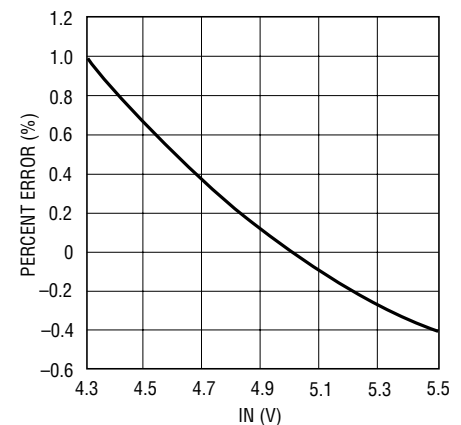

4095 G17

PIN FUNCTIONS

BAT (Pin 1): Single Cell Li-Ion Battery Pin. Provides charge current to the battery and regulates final float voltage to 4.2V.

GND (Pin 2): Ground

CHRG (Pin 3): Open-Drain Charge Status Output. The CHRG pin indicates the status of the battery charger. Four possible states are represented by CHRG: charging, not charging (i.e., the charge current is less than 1/10th of the full-scale charge current), unresponsive battery (i.e., the battery voltage remains below 2.9V after 1/2 hour of charging) and battery temperature out of range. CHRG requires a pull-up resistor and/or LED to provide indication.

SUSP (Pin 4): Suspend Mode Input. A voltage greater than 1.2V on the SUSP pin puts the LTC4095 into suspend mode, disables the charger and resets the termination timer. A weak pull-down current is internally applied to this pin to ensure it is low when the input is not being driven externally.

HPWR (Pin 5): High Power Select Input. A voltage greater than 1.2V on the HPWR pin will set the charge current to 100% of its programmed value. A voltage less than 0.4V on the pin will set the charge current to 20% of its programmed value. When used with a 1.74k PROG resistor this pin can toggle between low power and high power modes per USB specification. A weak pull-down current is internally applied to this pin to ensure it is low when the input is not being driven externally.

NTC (Pin 6): Input to the NTC Thermistor Monitoring Circuit. The NTC pin connects to a negative temperature coefficient thermistor which is typically co-packaged with the battery pack to determine if the battery is too hot or too cold to charge. If the battery temperature is out of range, charging is paused until the battery temperature re-enters the valid range. A low drift bias resistor is required from IN to NTC and a thermistor is required from NTC to ground. To disable the NTC function, the NTC pin should be grounded.

PROG (Pin 7): Charge Current Program and Charge Current Monitor Pin. Charge current is programmed by connecting a resistor from PROG to ground. When charging in constant-current mode, the PROG pin serves to 1V if the HPWR pin is pulled high, or 200mV if the HPWR pin is pulled low. The voltage on this pin always represents the battery current through the following formula:

$$I_{\text{BAT}} = \frac{\text{PROG}}{R_{\text{PROG}}} \cdot 800$$

IN (Pin 8): Input Supply Voltage. This pin provides power to the battery charger and should be bypassed with at least a 1µF capacitor. IN can range from 4.3V to 5.5V.

Exposed Pad (Pin 9): Ground. The exposed package pad is ground and must be soldered to the PCB ground for proper functionality and for maximum heat transfer.

SIMPLIFIED BLOCK DIAGRAM

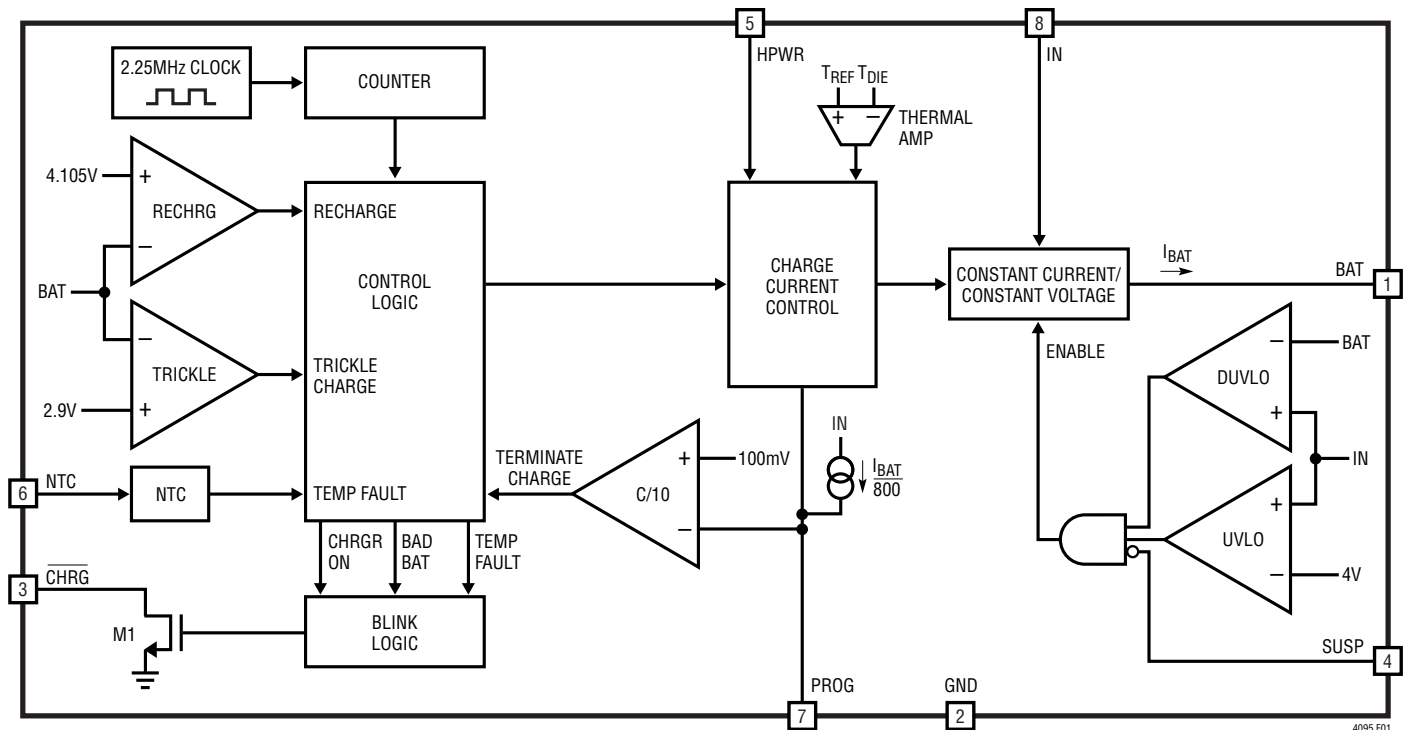

Figure 1. LTC4095 Block Diagram

OPERATION

Introduction

The LTC4095 is a linear battery charger designed to charge single-cell lithium-ion batteries. The charger uses a constant-current/constant-voltage charge algorithm with a charge current programmable up to 950mA. Additional features include automatic recharge, an internal termination timer, low-battery trickle charge conditioning, bad-battery detection, and a thermistor sensor input for out of temperature charge pausing.

Futhermore, the LTC4095 is capable of operating from a USB power source. In this application, charge current can be programmed to a maximum of 100mA or 500mA per USB power specifications.

Input Current vs Charge Current

The LTC4095 regulates the total current delivered to the BAT pin; this is the charge current. To calculate the total input current (i.e., the total current drawn from the IN pin),

it is necessary to sum the battery charge current, charger quiescent current and PROG pin current.

Undervoltage Lockout (UVLO)

The undervoltage lockout circuit monitors the input voltage (IN) and disables the battery charger until IN rises above V_{UVLO} (typically 4V). 200mV of hysteresis prevents oscillations around the trip point. In addition, a differential undervoltage lockout circuit disables the battery charger when IN falls to within V_{DUVLO} (typically 40mV) of the BAT voltage.

Suspend Mode

The LTC4095 can also be disabled by pulling the SUSP pin above 1.2V. In suspend mode, the battery drain current is reduced to 1.3 μ A and the input current is reduced to 8.5 μ A.

OPERATION

Charge Cycle Overview

When a battery charge cycle begins, the battery charger first determines if the battery is deeply discharged. If the battery voltage is below V_{TRKL} , typically 2.9V, an automatic trickle charge feature sets the battery charge current to 10% of the full-scale value.

Once the battery voltage is above 2.9V, the battery charger begins charging in constant-current mode. When the battery voltage approaches the 4.2V required to maintain a full charge, otherwise known as the float voltage, the charge current begins to decrease as the LTC4095 switches into constant-voltage mode.

Trickle Charge and Defective Battery Detection

Any time the battery voltage is below V_{TRKL} , the charger goes into trickle charge mode and reduces the charge current to 10% of the full-scale current. If the battery voltage remains below V_{TRKL} for more than 1/2 hour, the charger latches the bad-battery state, automatically terminates, and indicates via the \overline{CHRG} pin that the battery was unresponsive. If for any reason the battery voltage rises above V_{TRKL} , the charger will resume charging. Since the charger has latched the bad-battery state, if the battery voltage then falls below V_{TRKL} again but without rising past V_{RECHRG} first, the charger will immediately assume that the battery is defective. To reset the charger (i.e., when the dead battery is replaced with a new battery), simply remove the input voltage and reapply it or put the part in and out of suspend mode.

Charge Termination

The battery charger has a built-in safety timer that sets the total charge time for 4 hours. Once the battery voltage rises above V_{RECHRG} (typically 4.105V) and the charger enters constant-voltage mode, the 4-hour timer is started. After the safety timer expires, charging of the battery will discontinue and no more current will be delivered.

Automatic Recharge

After the battery charger terminates, it will remain off, drawing only microamperes of current from the battery. If the portable product remains in this state long enough, the battery will eventually self discharge. To ensure that the battery is always topped off, a charge cycle will automatically begin when the battery voltage falls below V_{RECHRG} (typically 4.105V). In the event that the safety timer is running when the battery voltage falls below V_{RECHRG} , it will reset back to zero. To prevent brief excursions below V_{RECHRG} from resetting the safety timer, the battery voltage must be below V_{RECHRG} for more than 1.7ms. The charge cycle and safety timer will also restart if the IN UVLO or DUVLO cycles low and then high (e.g., IN is removed and then replaced) or the charger enters and then exits suspend mode.

Programming Charge Current

The PROG pin serves both as a charge current program pin, and as a charge current monitor pin. By design, the PROG pin current is 1/800th of the battery charge current. Therefore, connecting a resistor from PROG to ground programs the charge current while measuring the PROG pin voltage allows the user to calculate the charge current.

Full-scale charge current is defined as 100% of the constant-current mode charge current programmed by the PROG resistor. In constant-current mode, the PROG pin serves to 1V if HPWR is high, which corresponds to charging at the full-scale charge current, or 200mV if HPWR is low, which corresponds to charging at 20% of the full-scale charge current. Thus, the full-scale charge current and desired program resistor for a given full-scale charge current are calculated using the following equations:

$$I_{CHG} = \frac{800V}{R_{PROG}}$$

$$R_{PROG} = \frac{800V}{I_{CHG}}$$

OPERATION

In any mode, the actual battery current can be determined by monitoring the PROG pin voltage and using the following equation:

$$I_{\text{BAT}} = \frac{\text{PROG}}{R_{\text{PROG}}} \cdot 800$$

Thermal Regulation

To prevent thermal damage to the IC or surrounding components, an internal thermal feedback loop will automatically decrease the programmed charge current if the die temperature rises to approximately 115°C. Thermal regulation protects the LTC4095 from excessive temperature due to high power operation or high ambient thermal conditions and allows the user to push the limits of the power handling capability with a given circuit board design without risk of damaging the LTC4095 or external components. The benefit of the LTC4095 thermal regulation loop is that charge current can be set according to actual conditions rather than worst-case conditions with the assurance that the battery charger will automatically reduce the current in worst-case conditions.

Charge Status Indication

The $\overline{\text{CHRG}}$ pin indicates the status of the battery charger. Four possible states are represented by $\overline{\text{CHRG}}$: charging, not charging, unresponsive battery and battery temperature out of range.

The signal at the $\overline{\text{CHRG}}$ pin can be easily recognized as one of the above four states by either a human or a microprocessor. The $\overline{\text{CHRG}}$ pin, which is an open-drain output, can drive an indicator LED through a current limiting resistor for human interfacing, or simply a pull-up resistor for microprocessor interfacing.

To make the $\overline{\text{CHRG}}$ pin easily recognized by both humans and microprocessors, the pin is either a DC signal of ON for charging, OFF for not charging, or it is switched at high frequency (35kHz) to indicate the two possible faults: unresponsive battery and battery temperature out of range.

When charging begins, $\overline{\text{CHRG}}$ is pulled low and remains low for the duration of a normal charge cycle. When the charge current has dropped to below 10% of the full-scale current, the $\overline{\text{CHRG}}$ pin is released (high impedance). If a fault occurs after the $\overline{\text{CHRG}}$ pin is released, the pin remains high impedance. However, if a fault occurs before the $\overline{\text{CHRG}}$ pin is released, the pin is switched at 35kHz. While switching, its duty cycle is modulated between a high and low value at a very low frequency. The low and high duty cycles are disparate enough to make an LED appear to be on or off thus giving the appearance of “blinking”. Each of the two faults has its own unique “blink” rate for human recognition as well as two unique duty cycles for microprocessor recognition.

Table 1 illustrates the four possible states of the $\overline{\text{CHRG}}$ pin when the battery charger is active.

Table 1. $\overline{\text{CHRG}}$ Output Pin

STATUS	FREQUENCY	MODULATION (BLINK) FREQUENCY	DUTY CYCLE
Charging	0Hz	0 Hz (Lo-Z)	100%
$I_{\text{BAT}} < C/10$	0Hz	0 Hz (Hi-Z)	0%
NTC Fault	35kHz	1.5Hz at 50%	6.25% to 93.75%
Bad Battery	35kHz	6.1Hz at 50%	12.5% to 87.5%

An NTC fault is represented by a 35kHz pulse train whose duty cycle varies between 6.25% and 93.75% at a 1.5Hz rate. A human will easily recognize the 1.5Hz rate as a “slow” blinking which indicates the out of range battery temperature while a microprocessor will be able to decode either the 6.25% or 93.75% duty cycles as an NTC fault.

If a battery is found to be unresponsive to charging (i.e., its voltage remains below V_{TRKL} for over 1/2 hour), the $\overline{\text{CHRG}}$ pin gives the battery fault indication. For this fault, a human would easily recognize the frantic 6.1Hz “fast” blinking of the LED while a microprocessor would be able to decode either the 12.5% or 87.5% duty cycles as a bad battery fault.

Although very improbable, it is possible that a duty cycle reading could be taken at the bright-dim transition (low duty cycle to high duty cycle). When this happens the duty cycle reading will be precisely 50%. If the duty cycle reading is 50%, system software should disqualify it and take a new duty cycle reading.

OPERATION

NTC Thermistor

The battery temperature is measured by placing a negative temperature coefficient (NTC) thermistor close to the battery pack. The NTC circuitry is shown in Figure 3.

To use this feature, connect the NTC thermistor, R_{NTC} , between the NTC pin and ground, and a bias resistor, R_{NOM} , from IN to NTC. R_{NOM} should be a 1% resistor with a value equal to the value of the chosen NTC thermistor at 25°C (R_{25}). A 100k thermistor is recommended since thermistor current is not measured by the LTC4095 and its current will have to be considered for compliance with USB specifications.

The LTC4095 will pause charging when the resistance of the NTC thermistor drops to 0.54 times the value of R_{25}

or approximately 54k (for a Vishay “Curve 1” thermistor, this corresponds to approximately 40°C). If the battery charger is in constant voltage mode, the safety timer will pause until the thermistor indicates a return to a valid temperature.

As the temperature drops, the resistance of the NTC thermistor rises. The LTC4095 is also designed to pause charging when the value of the NTC thermistor increases to 3.25 times the value of R_{25} . For a Vishay “Curve 1” thermistor, this resistance, 325k, corresponds to approximately 0°C. The hot and cold comparators each have approximately 3°C of hysteresis to prevent oscillation about the trip point. Grounding the NTC pin disables all NTC functionality.

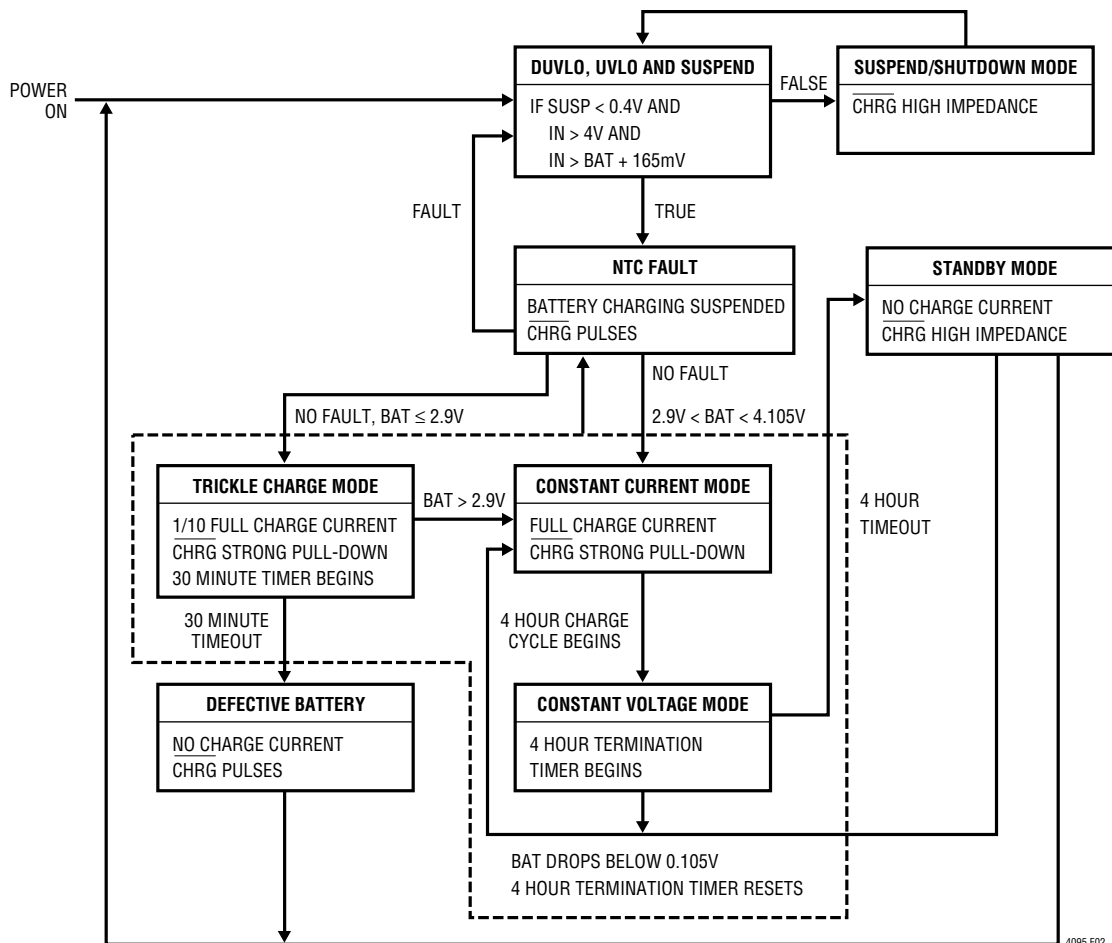

Figure 2. State Diagram of LTC4095 Operation

APPLICATIONS INFORMATION

Alternate NTC Thermistors and Biasing

The LTC4095 provides temperature qualified charging if a grounded thermistor and a bias resistor are connected to the NTC pin. By using a bias resistor whose value is equal to the room temperature resistance of the thermistor (R_{25}) the upper and lower temperatures are pre-programmed to approximately 40°C and 0°C, respectively (assuming a Vishay “Curve 1” thermistor).

The upper and lower temperature thresholds can be adjusted by either a modification of the bias resistor value or by adding a second adjustment resistor to the circuit. If only the bias resistor is adjusted, then either the upper or the lower threshold can be modified but not both. The other trip point will be determined by the characteristics of the thermistor. Using the bias resistor in addition to an adjustment resistor, both the upper and the lower temperature trip points can be independently programmed with the constraint that the difference between the upper and lower temperature thresholds cannot decrease. Examples of each technique are given below.

NTC thermistors have temperature characteristics which are indicated on resistance-temperature conversion tables. The Vishay-Dale thermistor NTHS0603N011-N1003F, used in the following examples, has a nominal value of 100k and follows the Vishay “Curve 1” resistance-temperature characteristic.

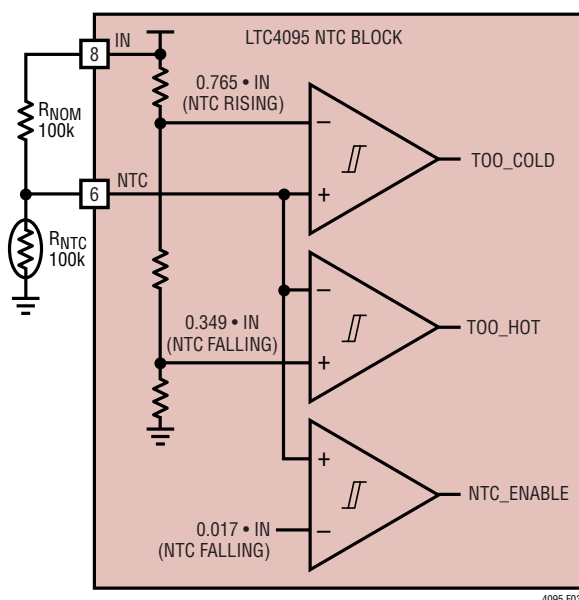

Figure 3. Typical NTC Thermistor Circuit

In the explanation below, the following notation is used.

R_{25} = Value of the thermistor at 25°C

$R_{NTC|COLD}$ = Value of thermistor at the cold trip point

$R_{NTC|HOT}$ = Value of the thermistor at the hot trip point

r_{COLD} = Ratio of $R_{NTC|COLD}$ to R_{25}

r_{HOT} = Ratio of $R_{NTC|HOT}$ to R_{25}

R_{NOM} = Primary thermistor bias resistor (see Figure 3)

R_1 = Optional temperature range adjustment resistor (see Figure 4)

The trip points for the LTC4095’s temperature qualification are internally programmed at $0.349 \cdot I_N$ for the hot threshold and $0.765 \cdot I_N$ for the cold threshold.

Therefore, the hot trip point is set when:

$$\frac{R_{NTC|HOT}}{R_{NOM} + R_{NTC|HOT}} \cdot I_N = 0.349 \cdot I_N$$

and the cold trip point is set when:

$$\frac{R_{NTC|COLD}}{R_{NOM} + R_{NTC|COLD}} \cdot I_N = 0.765 \cdot I_N$$

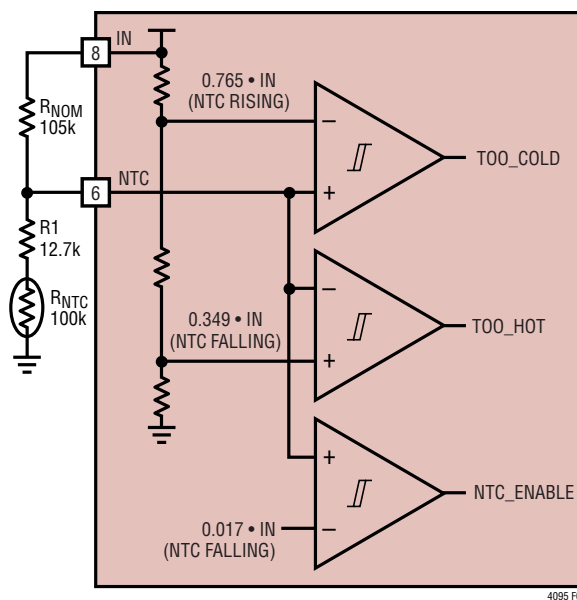

Figure 4. NTC Thermistor Circuit with Additional Bias Resistor

APPLICATIONS INFORMATION

Solving these equations for $R_{NTC|COLD}$ and $R_{NTC|HOT}$ results in the following:

$$R_{NTC|HOT} = 0.536 \cdot R_{NOM}$$

and

$$R_{NTC|COLD} = 3.25 \cdot R_{NOM}$$

By setting R_{NOM} equal to R25, the above equations result in $r_{HOT} = 0.536$ and $r_{COLD} = 3.25$. Referencing these ratios to the Vishay Resistance-Temperature Curve 1 chart gives a hot trip point of about 40°C and a cold trip point of about 0°C. The difference between the hot and cold trip points is approximately 40°C.

By using a bias resistor, R_{NOM} , different in value from R25, the hot and cold trip points can be moved in either direction. The temperature span will change somewhat due to the nonlinear behavior of the thermistor. The following equations can be used to easily calculate a new value for the bias resistor:

$$R_{NOM} = \frac{r_{HOT}}{0.536} \cdot R25$$

$$R_{NOM} = \frac{r_{COLD}}{3.25} \cdot R25$$

where r_{HOT} and r_{COLD} are the resistance ratios at the desired hot and cold trip points. Note that these equations are linked. Therefore, only one of the two trip points can be chosen, the other is determined by the default ratios designed in the IC. Consider an example where a 60°C hot trip point is desired.

From the Vishay Curve 1 R-T characteristics, r_{HOT} is 0.2488 at 60°C. Using the above equation, R_{NOM} should be set to 46.4k. With this value of R_{NOM} , the cold trip point is about 16°C. Notice that the span is now 44°C rather than the previous 40°C.

The upper and lower temperature trip points can be independently programmed by using an additional bias resistor as shown in Figure 4. The following formulas can be used to compute the values of R_{NOM} and R1:

$$R_{NOM} = \frac{r_{COLD} - r_{HOT}}{2.714} \cdot R25$$

$$R1 = 0.536 \cdot R_{NOM} - r_{HOT} \cdot R25$$

For example, to set the trip points to 0°C and 45°C with a Vishay Curve 1 thermistor choose:

$$R_{NOM} = \frac{3.266 - 0.4368}{2.714} \cdot 100k = 104.2k$$

the nearest 1% value is 105k.

$$R1 = 0.536 \cdot 105k - 0.4368 \cdot 100k = 12.6k$$

the nearest 1% value is 12.7k. The final solution is shown in Figure 4 and results in an upper trip point of 45°C and a lower trip point of 0°C.

USB and Wall Adapter Power

Although the LTC4095 is designed to draw power from a USB port to charge Li-Ion batteries, a wall adapter can also be used. Figure 5 shows an example of how to combine wall adapter and USB power inputs. A P-channel MOSFET, MP1, is used to prevent back conduction into the USB port when a wall adapter is present and Schottky diode, D1, is used to prevent USB power loss through the 1k pull-down resistor.

Typically, a wall adapter can supply significantly more current than the 500mA-limited USB port. Therefore, an N-channel MOSFET, MN1, and an extra program resistor are used to increase the maximum charge current to 950mA when the wall adapter is present.

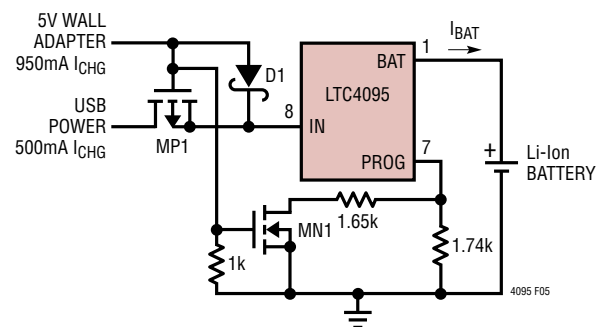

Figure 5. Combining Wall Adapter and USB Power

Power Dissipation

The conditions that cause the LTC4095 to reduce charge current through thermal feedback can be approximated by considering the power dissipated in the IC. For high

APPLICATIONS INFORMATION

charge currents, the LTC4095 power dissipation is approximately:

$$P_D = (I_N - I_{BAT}) \cdot I_{BAT}$$

where P_D is the power dissipated, I_N is the input supply voltage, I_{BAT} is the battery voltage and I_{BAT} is the charge current. It is not necessary to perform any worst-case power dissipation scenarios because the LTC4095 will automatically reduce the charge current to maintain the die temperature at approximately 115°C. However, the approximate ambient temperature at which the thermal feedback begins to protect the IC is:

$$T_A = 115^\circ\text{C} - P_D \theta_{JA}$$

$$T_A = 115^\circ\text{C} - (I_N - I_{BAT}) \cdot I_{BAT} \cdot \theta_{JA}$$

Example: Consider an LTC4095 operating from a USB port providing 500mA to a 3.5V Li-Ion battery. The ambient temperature above which the LTC4095 will begin to reduce the 500mA charge current is approximately:

$$T_A = 115^\circ\text{C} - (5\text{V} - 3.5\text{V}) \cdot (500\text{mA}) \cdot 60^\circ\text{C/W}$$

$$T_A = 115^\circ\text{C} - 0.75\text{W} \cdot 60^\circ\text{C/W} = 115^\circ\text{C} - 45^\circ\text{C}$$

$$T_A = 70^\circ\text{C}$$

The LTC4095 can be used above 70°C, but the charge current will be reduced from 500mA. The approximate current at a given ambient temperature can be calculated:

$$I_{BAT} = \frac{115^\circ\text{C} - T_A}{(I_N - I_{BAT}) \cdot \theta_{JA}}$$

Using the previous example with an ambient temperature of 88°C, the charge current will be reduced to approximately:

$$I_{BAT} = \frac{115^\circ\text{C} - 88^\circ\text{C}}{(5\text{V} - 3.5\text{V}) \cdot 60^\circ\text{C/W}} = \frac{27^\circ\text{C}}{90^\circ\text{C/A}} = 300\text{mA}$$

Furthermore, the voltage at the PROG pin will change proportionally with the charge current as discussed in the Programming Charge Current section.

It is important to remember that LTC4095 applications do not need to be designed for worst-case thermal conditions since the IC will automatically reduce power dissipation when the junction temperature reaches approximately 115°C.

USB Inrush Limiting

When a USB cable is plugged into a portable product, the inductance of the cable and the high-Q ceramic input capacitor form an L-C resonant circuit. If there is not much impedance in the cable, it is possible for the voltage at the input of the product to reach as high as twice the USB voltage (~10V) before it settles out. In fact, due to the high voltage coefficient of many ceramic capacitors (a nonlinearity), the voltage may even exceed twice the USB voltage. To prevent excessive voltage from damaging the LTC4095 during a hot insertion, the soft connect circuit in Figure 6 can be employed.

In this circuit, capacitor C2 holds MN1 off when the cable is first connected. Eventually C2 begins to charge up to the USB input voltage applying increasing gate support to MN1. The long time constant of R1 and C1 prevent the current from building up in the cable too fast thus dampening out any resonant overshoot.

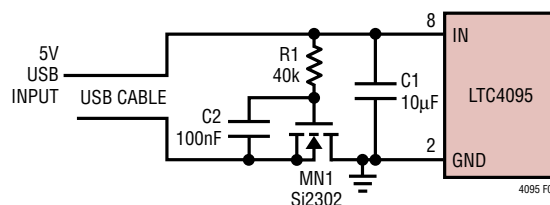

Figure 6. USB Soft Connect Circuit

Battery Charger Stability Considerations

The LTC4095's battery charger contains both a constant-voltage and a constant-current control loop. The constant-voltage loop is stable without any compensation when a battery is connected with low impedance leads. Excessive lead length, however, may add enough series inductance to require a bypass capacitor of at least 1µF from BAT to GND. Furthermore, a 4.7µF capacitor in series with a 0.2Ω to 1Ω resistor from BAT to GND is required to keep ripple voltage low when the battery is disconnected.

High value, low ESR multilayer ceramic chip capacitors reduce the constant-voltage loop phase margin, possibly resulting in instability. Ceramic capacitors up to 22µF may be used in parallel with a battery, but larger ceramics should be decoupled with 0.2Ω to 1Ω of series resistance.

APPLICATIONS INFORMATION

In constant-current mode, the PROG pin is in the feedback loop rather than the battery voltage. Because of the additional pole created by any PROG pin capacitance, capacitance on this pin must be kept to a minimum. With no additional capacitance on the PROG pin, the battery charger is stable with program resistor values as high as 25k. However, additional capacitance on this node reduces the maximum allowed program resistor. The pole frequency at the PROG pin should be kept above 100kHz. Therefore, if the PROG pin has a parasitic capacitance, C_{PROG} , the following equation should be used to calculate the maximum resistance value for R_{PROG} :

$$R_{\text{PROG}} \leq \frac{1}{2\pi \cdot 10^5 \cdot C_{\text{PROG}}}$$

The stability of the constant-current loop also needs to be considered when average, rather than instantaneous, battery current is of interest to the user. For example, if a switching power supply operating in low current mode is connected in parallel with the battery, the average current being pulled out of the BAT pin is typically of more interest than the instantaneous current pulses. In such a case, a simple RC filter can be used on the PROG pin to measure the average battery current as shown in Figure 7. A 10k resistor has been added between the PROG pin and the filter capacitor to ensure stability.

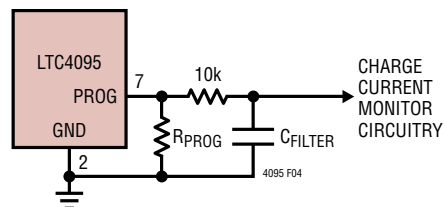

Figure 7. Isolating Capacitive Load on PROG Pin and Filtering

Board Layout Considerations

In order to deliver maximum charge current under all conditions, it is critical that the exposed metal pad on the backside of the LTC4095 package is soldered to the PC board ground. Correctly soldered to a 2500mm² double-sided 1oz. copper board the LTC4095 has a thermal resistance of approximately 60°C/W. Failure to make thermal contact between the Exposed Pad on the backside of the package and the copper board will result in thermal resistances far greater than 60°C/W. As an example, a correctly soldered LTC4095 can deliver over 950mA to a battery from a 5V supply at room temperature. Without a backside thermal connection, this number could drop to less than 500mA.

IN Bypass Capacitor

Many types of capacitors can be used for input bypassing; however, caution must be exercised when using multi-layer ceramic capacitors. Because of the self-resonant and high Q characteristics of some types of ceramic capacitors, high voltage transients can be generated under some start-up conditions, such as connecting the charger input to a live power source. For more information, refer to Application Note 88.

TYPICAL APPLICATION

500mA Single-Cell Li-Ion Charger

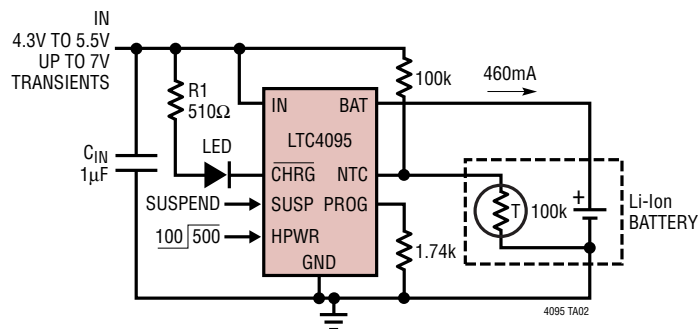

RELATED PARTS

PART NUMBER	DESCRIPTION	COMMENTS
Battery Chargers		
LTC1734	Lithium-Ion Linear Battery Charger in ThinSOT™	Simple ThinSOT Charger, No Blocking Diode, No Sense Resistor Needed
LTC1734L	Lithium-Ion Linear Battery Charger in ThinSOT	Low Current Version of LTC1734, 50mA ≤ I _{CHRG} ≤ 180mA
LTC4052	Monolithic Lithium-Ion Battery Pulse Charger	No Blocking Diode or External Power FET Required, ≤1.5A Charge Current
LTC4053	USB Compatible Monolithic Li-Ion Battery Charger	Standalone Charger with Programmable Timer, Up to 1.25A Charge Current
LTC4054	Standalone Linear Li-Ion Battery Charger with Integrated Pass Transistor in ThinSOT	Thermal Regulation Prevents Overheating, C/10 Termination, C/10 Indicator, Up to 800mA Charge Current
LTC4057	Lithium-Ion Linear Battery Charger	Up to 800mA Charge Current, Thermal Regulation, ThinSOT Package
LTC4058	Standalone 950mA Lithium-Ion Charger in DFN	C/10 Charge Termination, Battery Kelvin Sensing, ±7% Charge Accuracy
LTC4059	900mA Linear Lithium-Ion Battery Charger	2mm × 2mm DFN Package, Thermal Regulation, Charge Current Monitor Output
LTC4059A	900mA Linear Lithium-Ion Battery Charger	2mm × 2mm DFN Package, Thermal Regulation, Charge Current Monitor Output, ACPR Function
LTC4061	Standalone Li-Ion Charger with Thermistor Interface	4.2V, ±0.35% Float Voltage, Up to 1A Charge Current, 3mm × 3mm DFN
LTC4061-4.4	Standalone Li-Ion Charger with Thermistor Interface	4.4V (Max), ±0.4% Float Voltage, Up to 1A Charge Current, 3mm × 3mm DFN
LTC4062	Standalone Linear Li-Ion Battery Charger with Micropower Comparator	4.2V, ±0.35% Float Voltage, Up to 1A Charge Current, 3mm × 3mm DFN
LTC4063	Li-Ion Charger with Linear Regulator	Up to 1A Charge Current, 100mA, 125mV LDO, 3mm × 3mm DFN
LTC4065/LTC4065A	Standalone 750mA Li-Ion Charger in 2mm × 2mm DFN	4.2V, ±0.6% Float Voltage, Up to 750mA Charge Current, 2mm × 2mm 6-Pin DFN
LTC4069	Standalone Li-Ion Battery Charger with NTC Thermistor Input in 2mm × 2mm DFN	4.2V, ±0.6% Float Voltage, Up to 750mA Charge Current, Timer Termination + C/10 Detection Output
Power Management		
LTC3405/LTC3405A	300mA (I _{OUT}), 1.5MHz, Synchronous Step-Down DC/DC Converter	95% Efficiency, V _{IN} : 2.7V to 6V, V _{OUT} = 0.8V, I _Q = 20µA, I _{SD} < 1µA, ThinSOT Package
LTC3406/LTC3406A	600mA (I _{OUT}), 1.5MHz, Synchronous Step-Down DC/DC Converter	95% Efficiency, V _{IN} : 2.5V to 5.5V, V _{OUT} = 0.6V, I _Q = 20µA, I _{SD} < 1µA, ThinSOT Package
LTC3440	600mA (I _{OUT}), 2MHz, Synchronous Buck-Boost DC/DC Converter	95% Efficiency, V _{IN} : 2.5V to 5.5V, V _{OUT} = 2.5V, I _Q = 25µA, I _{SD} < 1µA, MS Package
LTC4411/LTC4412	Low Loss PowerPath™ Controller in ThinSOT	Automatic Switching Between DC Sources, Load Sharing, Replaces ORing Diodes
LTC4413	Dual Ideal Diode in DFN	2-Channel Ideal Diode ORing, Low Forward ON Resistance, Low Regulated Forward Voltage, 2.5V ≤ V _{IN} ≤ 5.5V

ThinSOT and PowerPath are trademarks of Linear Technology Corporation.