

FEATURES

- **V_{IN} Range: 2.6V to 4.4V**
- **Ultralow Power**
 Operating Current: 14μA
 Shutdown Current: <1μA
- **No Inductors**
- **Short-Circuit/Thermal Protected**
- **Ultrasmall Application Circuit (<0.045in²)**
- **Low Profile (1mm) ThinSOT™**
- Step-Up Charge Pump Generates 5V
- Output Current: 10mA
- V_{IN} to V_{OUT} Direct Connection for 3V SIMs
- Switching Frequency: 900kHz
- Soft-Start Limits Inrush Current at Turn-On
- Output Driven to Ground During Shutdown

APPLICATIONS

- GSM Cellular Telephones
- PCS/DCS Cellular Telephones
- Portable POS Terminals

DESCRIPTION

The LTC[®]1986 is a micropower charge pump DC/DC converter that provides power for either 3V or 5V GSM SIM cards. It operates in one of three modes: V_{OUT} = 5V (5V mode), V_{OUT} = V_{IN} (3V mode) or shutdown. The input voltage range is 2.6V to 4.4V and the part can provide 10mA of output current. The LTC1986 allows V_{IN} to drop as low as 2.6V by providing a boost feature in 3V mode. In 3V mode, V_{OUT} is connected directly to V_{IN} through a 2.5Ω switch until V_{IN} drops below 2.85V. When V_{IN} is below 2.85V, the part automatically boosts V_{OUT} to maintain a regulated 2.9V output, thereby ensuring V_{OUT} stays within the 3V SIM V_{CC} specification.

Extremely low operating current (14μA typical with no load) and low external parts count make the part ideally suited for small, light load battery-powered applications. The total PCB area of the application circuit shown below is less than 0.045in². Protection features include inrush current limiting, undervoltage lockout, short circuit and thermal overload protection. The LTC1986 is available in a low profile (1mm) SOT-23 package.

LT, LTC and LT are registered trademarks of Linear Technology Corporation.
 ThinSOT is a trademark of Linear Technology Corporation.

TYPICAL APPLICATION

3V/5V SIM Power Supply

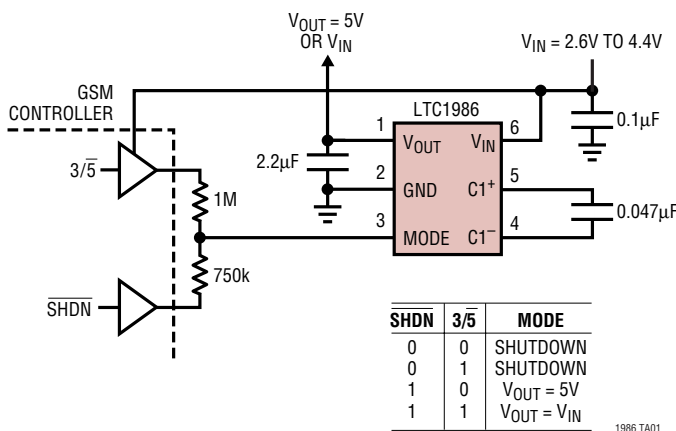

Output Voltage vs Input Voltage

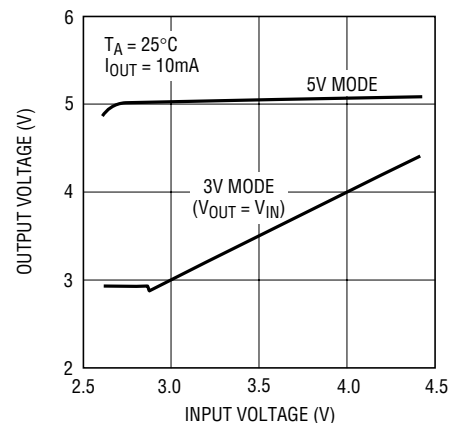

ABSOLUTE MAXIMUM RATINGS

(Note 1)

V_{IN} , V_{OUT} to GND	-0.3V to 6V
All Other Pins to GND	-0.3V to 6V
V_{OUT} Short-Circuit Duration	Indefinite
Operating Temperature Range (Note 2)	-40°C to 85°C
Storage Temperature Range	-65°C to 150°C
Lead Temperature (Soldering, 10 sec)	300°C

PACKAGE/ORDER INFORMATION

	ORDER PART NUMBER
	LTC1986ES6
	S6 PART MARKING
	LTKX

Consult LTC Marketing for parts specified with wider operating temperature ranges.

ELECTRICAL CHARACTERISTICS

The ● denotes specifications which apply over the full operating temperature range, otherwise specifications are $T_A = 25^\circ\text{C}$. $V_{IN} = V_{MIN}$ to V_{MAX} , $MODE = V_{IN}$, $C1 = 0.047\mu\text{F}$, $C_{OUT} = 2.2\mu\text{F}$, unless otherwise specified.

PARAMETER	CONDITIONS	MIN	TYP	MAX	UNITS
V_{IN} Operating Voltage		● 2.6		4.4	V
V_{OUT} Output Voltage	Shutdown Mode		0		V
	3V Mode, $V_{IN} = 2.85\text{V}$ to 4.4V , $I_{OUT} \leq 10\text{mA}$		$V_{IN} - 0.025$		V
	3V Mode, $V_{IN} < 2.85\text{V}$, $I_{OUT} < 10\text{mA}$	● 2.75	2.9	3.05	V
	5V Mode, $V_{IN} < 2.7\text{V}$, $I_{OUT} \leq 10\text{mA}$	● 4.55	5	5.25	V
	5V Mode, $V_{IN} = 2.7\text{V}$ to 4.4V , $I_{OUT} \leq 10\text{mA}$	● 4.75	5	5.25	V
V_{IN} Operating Current	Shutdown Mode, $V_{MODE} = 0\text{V}$	●	0.001	1	μA
	3V Mode, $I_{OUT} = 0\text{mA}$	●	10	25	μA
	5V Mode, $I_{OUT} = 0\text{mA}$	●	14	30	μA
V_{IN} -to- V_{OUT} ON Resistance	3V Mode, $V_{IN} = 3\text{V}$	●	2.5	5	Ω
V_{OUT} Short-Circuit Current	3V or 5V Mode, $V_{OUT} = 0\text{V}$	●	100	200	mA
V_{OUT} Discharge Resistance	$V_{IN} = 3\text{V}$	●	70	200	Ω
Switching Frequency	Oscillator Free-Running		900		kHz
MODE Input Ranges	Shutdown Mode	● 0		$V_{IN}/2 - 0.1$	V
	5V Mode	● $V_{IN}/2 + 0.1$		$V_{IN} - 1.0$	V
	3V Mode	● $V_{IN} - 0.25$		V_{IN}	V
MODE Input Current		● -1		1	μA
Undervoltage Lockout Threshold			1.4		V

Note 1: Absolute Maximum Ratings are those values beyond which the life of a device may be impaired.

Note 2: The LTC1986E is guaranteed to meet performance specifications from 0°C to 70°C . Specifications over the -40°C to 85°C operating temperature range are assured by design, characterization and correlation with statistical process controls.

TYPICAL PERFORMANCE CHARACTERISTICS

Output Voltage vs Output Current (3V Mode)

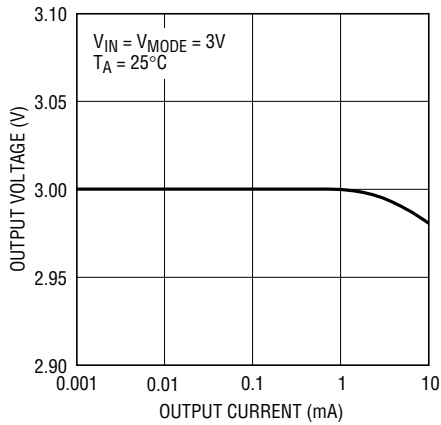

1986 G01

Efficiency vs Input Voltage

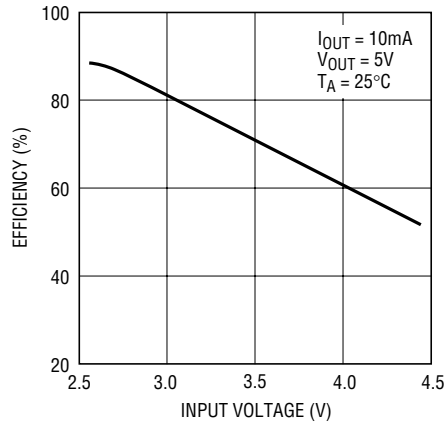

1986 G02

Efficiency vs Output Current

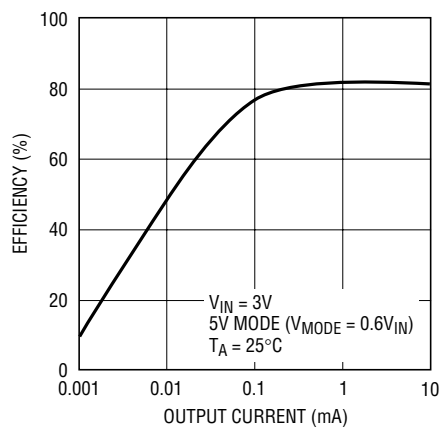

1986 G03

Positive Supply Current vs Input Voltage

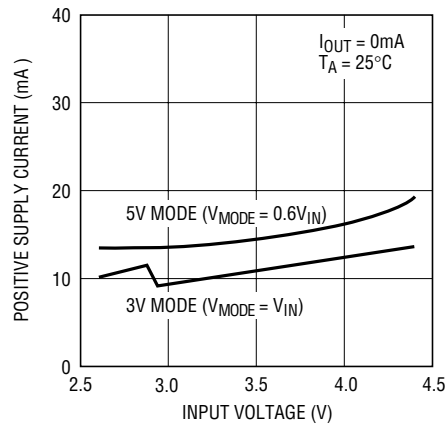

1986 G04

Output Voltage Ripple (5V Mode)

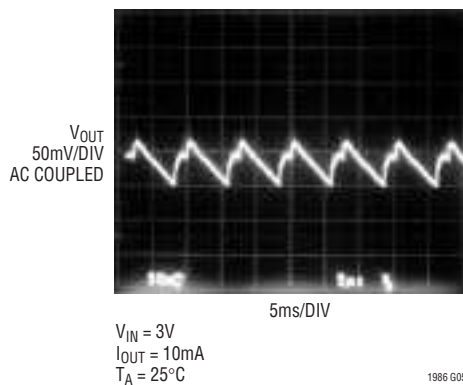

1986 G05

Output Voltage vs VMODE Waveforms

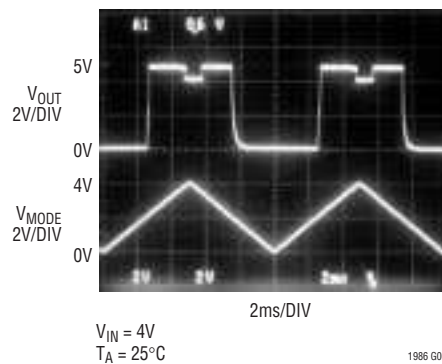

1986 G06

PIN FUNCTIONS

V_{OUT} (Pin 1): Charge Pump Output. The V_{OUT} voltage will depend on the MODE pin input voltage. V_{OUT} = 0V in shutdown mode, V_{OUT} = V_{IN} in 3V mode and V_{OUT} = 5V in 5V mode. The LTC1986 provides a 2.9V regulated output when the part is in 3V mode and the V_{IN} voltage is below 2.85V. This feature allows the input voltage to be below the minimum voltage specification for 3V SIM cards without violating the SIM V_{CC} specification. Bypass the V_{OUT} pin with a $\geq 2.2\mu\text{F}$ low ESR capacitor to ground.

GND (Pin 2): Ground. Connect to a ground plane for best performance.

MODE (Pin 3): MODE Input Pin. The voltage on this pin determines the operating mode of the LTC1986. It operates in either shutdown mode, 3V mode or 5V mode depending on the MODE pin voltage with respect to V_{IN}.

The three different modes can be realized by using two external resistors as shown in the typical application circuit. If $V_{\text{MODE}} < V_{\text{IN}}/2 - 0.1\text{V}$, the part is in shutdown mode. If $V_{\text{IN}}/2 + 0.1\text{V} < V_{\text{MODE}} < V_{\text{IN}} - 1\text{V}$, the part is in 5V mode. If $V_{\text{IN}} - 0.25\text{V} < V_{\text{MODE}}$, the part is in 3V mode. To achieve the lowest possible shutdown current, the MODE pin should be pulled to 0V, i.e., both the SHDN and 3/5 signals from the controller should be pulled low.

C1⁻ (Pin 4): Charge Pump Flying Capacitor Negative Terminal.

C1⁺ (Pin 5): Charge Pump Flying Capacitor Positive Terminal.

V_{IN} (Pin 6): Input Supply Voltage. Bypass V_{IN} with a $\geq 0.1\mu\text{F}$ low ESR capacitor to ground.

SIMPLIFIED BLOCK DIAGRAM

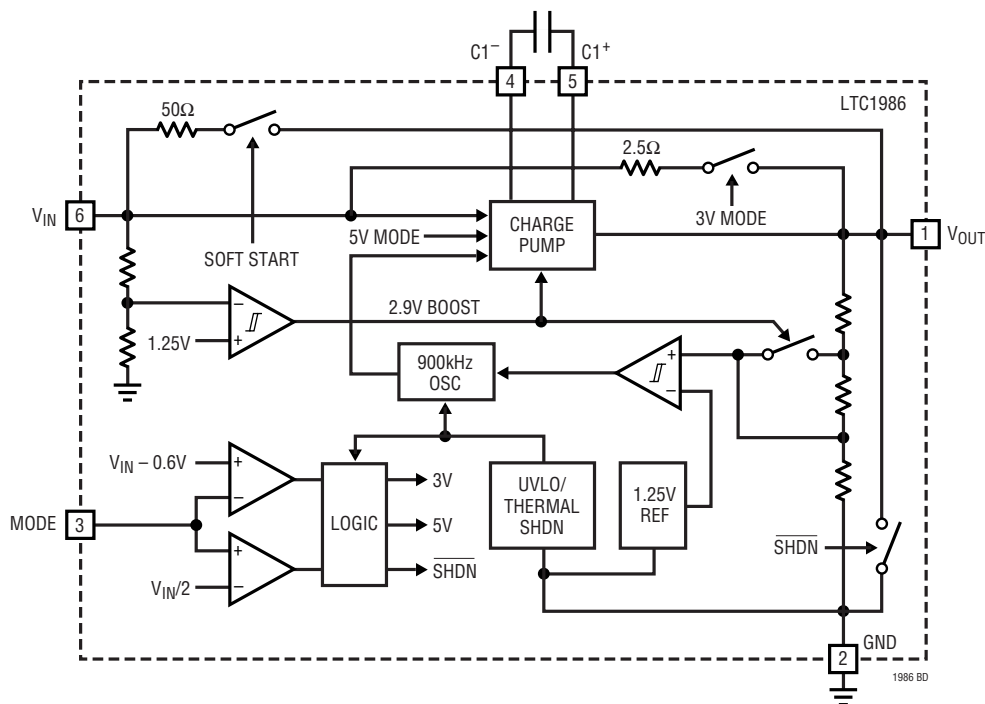

APPLICATIONS INFORMATION

Operation

The LTC1986 is a charge pump DC/DC converter designed specifically to supply V_{CC} power for either 3V or 5V SIM cards. The part can operate in one of three modes: a low power shutdown mode which disconnects V_{IN} from V_{OUT} and actively pulls down the V_{OUT} supply, 3V mode which provides a direct connection between V_{IN} and V_{OUT} for powering 3V SIM cards, and 5V mode which provides a regulated 5V output for powering 5V SIM cards. In 5V mode, regulation is achieved by sensing the output voltage through a resistor divider and enabling the charge pump as needed to maintain regulation.

When the charge pump is enabled, a 2-phase nonoverlapping clock controls the internal charge pump switches. Flying capacitor C1 is charged to V_{IN} on phase one of the clock. On phase two of the clock, C1 is stacked in series with V_{IN} and connected to V_{OUT} through an internal switch. This sequence of charging and discharging the flying capacitor occurs at a free-running frequency of 900kHz (typ) and continues until the divided output voltage reaches the upper trip point of the comparator. Once the output is in regulation, the charge pump is disabled. This method of bursting the charge pump on and off enables the LTC1986 to achieve high efficiency at extremely low output loads.

Mode Selection

The operating mode is determined by the voltage applied to the MODE pin. The MODE pin has three voltage thresholds—all of which are referenced to V_{IN} :

$$\begin{aligned} \text{Shutdown Mode} &\Rightarrow V_{\text{MODE}} < V_{\text{IN}}/2 - 0.1\text{V} \\ \text{5V Mode} &\Rightarrow V_{\text{IN}}/2 + 0.1\text{V} < V_{\text{MODE}} < V_{\text{IN}} - 1\text{V} \\ \text{3V Mode} &\Rightarrow V_{\text{IN}} - 0.25\text{V} < V_{\text{MODE}} \end{aligned}$$

For example, if $V_{IN} = 3\text{V}$, then the following table applies:

V_{MODE}	OPERATING MODE
0V to 1.4V	Shutdown Mode
1.6V to 2V	5V Mode
2.75V to 3V	3V Mode ($V_{\text{OUT}} = V_{\text{IN}}$)

The three modes can be selected using two totem pole digital outputs and two external resistors as shown in Figure 1.

Shutdown mode disconnects V_{IN} from V_{OUT} and enables an internal pull-down device which forces V_{OUT} to GND. To achieve the lowest possible quiescent current in shutdown mode, the voltage on the MODE pin should be pulled below 0.4V. 3V mode connects V_{OUT} to V_{IN} through a 2.5 Ω internal switch. The LTC1986 has the additional capability of boosting V_{OUT} to a regulated 2.9V in 3V mode when the input voltage drops below 2.85V. This ensures that the 3V SIM V_{CC} specification is not violated if V_{IN} drops below 2.7V during transients or low battery conditions.

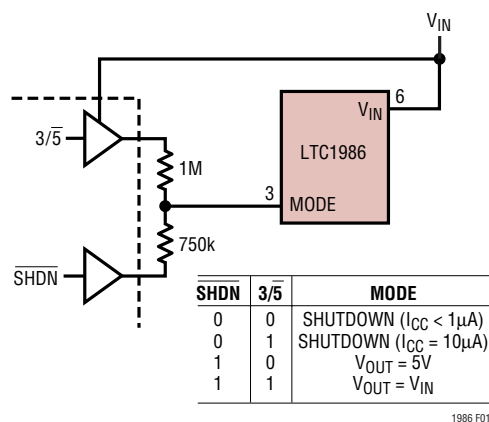

Figure 1

Capacitor Selection

For best performance, it is recommended that low ESR capacitors be used for both C_{IN} and C_{OUT} to reduce noise and ripple. The C_{IN} and C_{OUT} capacitors should be either ceramic or tantalum. Ceramic capacitors will provide the smallest size for a given capacitance. If the input source impedance is very low ($< 0.5\Omega$), C_{IN} may not be needed. For best performance, C_{OUT} should be 2.2 μF or greater. Ceramic capacitors are also recommended for the flying capacitor C1 with values between 0.047 μF and 0.22 μF . If a small value output capacitor (3.3 μF or less) is used, a small flying capacitor should also be used to prevent high output ripple in 5V mode. The recommended capacitor values to minimize board space and cost are: $C_{\text{IN}} = 0.1\mu\text{F}$, $C_1 = 0.047\mu\text{F}$ and $C_{\text{OUT}} = 2.2\mu\text{F}$ (ceramic).

APPLICATIONS INFORMATION

Output Ripple

Normal 5V mode operation produces voltage ripple on the V_{OUT} pin. Output voltage ripple is required for regulation. Low frequency ripple exists due to the hysteresis in the sense comparator and propagation delays in the charge pump enable/disable circuits. High frequency ripple is also present mainly from the ESR (equivalent series resistance) in the output capacitor. Typical output ripple with $V_{IN} = 3V$ under maximum load is $75mV_{P-P}$ with a low ESR $2.2\mu F$ output capacitor and a $0.047\mu F$ C1 capacitor. For applications requiring V_{IN} to exceed 3.3V or for applications requiring $<75mV$ of peak-to-peak ripple, a $3.3\mu F$ to $10\mu F$ C_{OUT} capacitor is recommended. Slight further decreases in output ripple can be achieved by using C_{OUT} capacitors larger than $10\mu F$.

Protection Features

The LTC1986 provides several protection features. Undervoltage lockout prevents any current from flowing between V_{IN} and V_{OUT} until the V_{IN} voltage exceeds 1.4V (typ). This prevents undesirable glitches during power-up. The parts also limit inrush current during power-up to under 200mA regardless of V_{IN} voltage, operating mode and output load by disabling the main direct connect switch (3V mode) or the charge pump (5V mode) and enabling a 50Ω series switch between V_{IN} and V_{OUT} until V_{OUT} reaches $V_{IN}/2$. The parts are also short-circuit protected and can survive an indefinite short from V_{OUT} to GND regardless of operating mode or input voltage. In the event of thermal overload, the parts will enter thermal shutdown if the junction temperature exceeds $165^{\circ}C$ and return to normal operation once the junction temperature drops to $150^{\circ}C$.

PACKAGE DESCRIPTION

S6 Package
6-Lead Plastic TSOT-23
 (Reference LTC DWG # 05-08-1636)

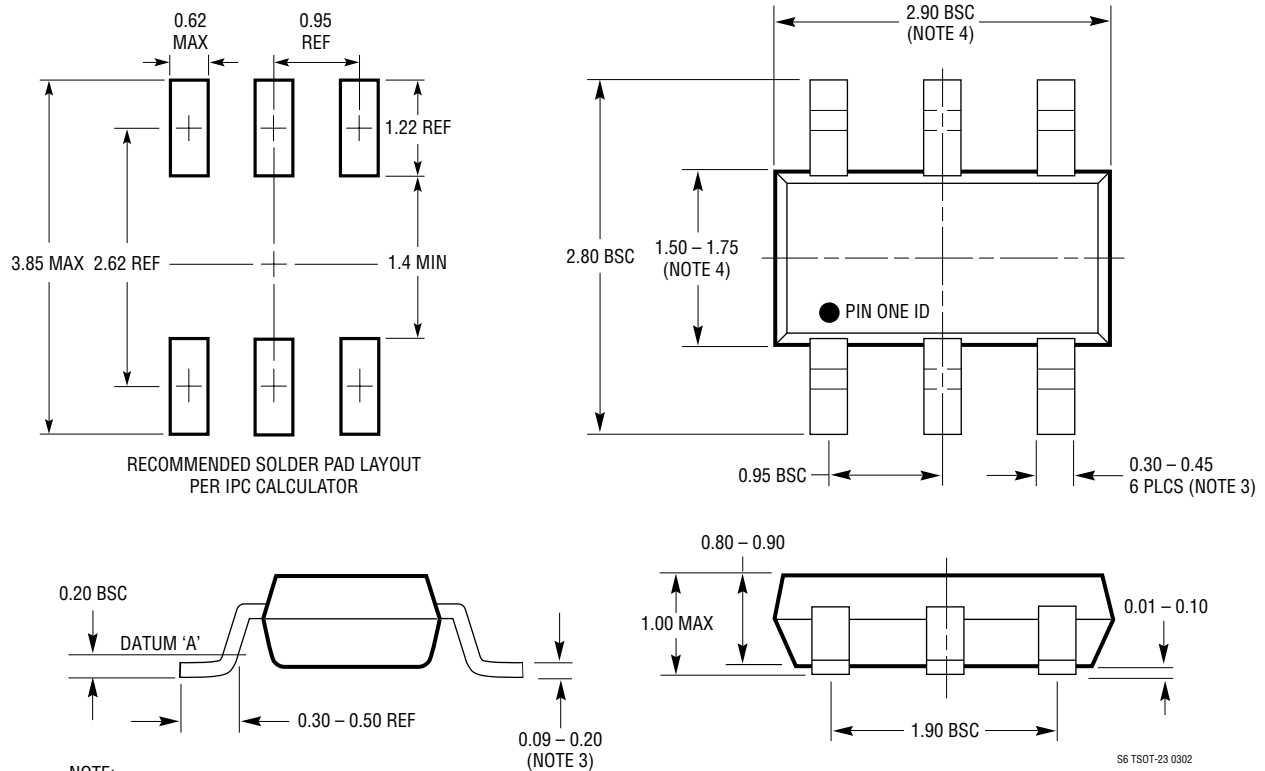

NOTE:

1. DIMENSIONS ARE IN MILLIMETERS
2. DRAWING NOT TO SCALE
3. DIMENSIONS ARE INCLUSIVE OF PLATING
4. DIMENSIONS ARE EXCLUSIVE OF MOLD FLASH AND METAL BURR
5. MOLD FLASH SHALL NOT EXCEED 0.254mm
6. JEDEC PACKAGE REFERENCE IS MO-193

S6 TSOT-23 0302

TYPICAL APPLICATION

3V/5V SIM Power Supply

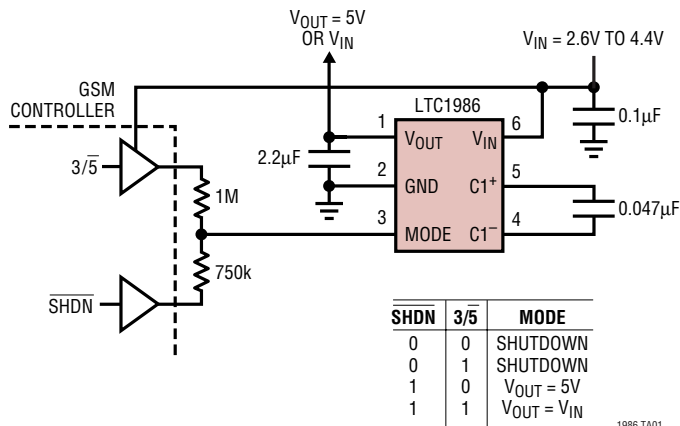

RELATED PARTS

PART NUMBER	DESCRIPTION	COMMENTS
LTC1503	High Efficiency Step-Down Charge Pump	V _{IN} = 2.4V to 6V, 100mA Output Current
LTC1517	Micropower Charge Pump in 5-Pin ThinSOT™	I _{CC} = 6µA, Short-Circuit/Thermal Protected
LTC1555	SIM Power Supply and Level Translator	V _{IN} = 2.7V to 10V, 10kV ESD on SIM Contact Pins
LT1615	Micropower Step-Up DC/DC Converter in ThinSOT	V _{IN} = 1.2V to 15V; 350mA, 36V Switch
LT1682	Charge Pump Plus Low Noise LDO Regulator in MS8	50mA Output Current; 60µV _{RMS} Output Noise
LTC1754-5	5V Charge Pump with Shutdown in ThinSOT	50mA Output Current, I _{CC} = 13µA
LTC1754-3.3	3.3V Charge Pump with Shutdown in ThinSOT	V _{IN} = 2V to 4.4V; I _{OUT} = 40mA; Ripple = 23mV _{P-P}
LT1761	Low Noise, 100mA Micropower LDO Regulator	I _Q = 20µA, 20µV _{RMS} Noise, ThinSOT
LTC1755	Smart Card Power Supply and Level Translator	ISO 7816-3 and EMV Compliant
LTC1911-1.5/LTC1911-1.8	High Efficiency, Inductorless, Low Noise Step-Down DC/DC Converter	Up to 85% Efficiency, 1.5MHz, V _{IN} : 2.7V to 5.5V, I _Q = 180µA, MS8
LTC3250-1.5	High Efficiency, Inductorless, Low Noise Step-Down DC/DC Converter	Up to 90% Efficiency, 1.5MHz, V _{IN} : 3.1V to 5.5V, I _Q = 35µA, ThinSOT