

FEATURES

- Improved Direct Replacement for AD7545A and AD7545
- DNL and INL Over Temperature: $\pm 0.5\text{LSB}$
- Gain Error: $\pm 1\text{LSB}$ Maximum
- 4-Quadrant Multiplication
- Single 5V or 15V Supply
- Low Power Consumption
- Low Cost

APPLICATIONS

- Process Control and Industrial Automation
- Software Controlled Gain Adjustment
- Digitally Controlled Filter and Power Supplies
- Automatic Test Equipment

DESCRIPTION

The LTC[®]7545A is a 12-bit multiplying digital-to-analog converter (DAC) with a microprocessor compatible parallel input. It is a superior pin compatible replacement for the industry standard AD7545A and AD7545. Improvements include better accuracy, better stability over temperature and supply variations and lower sensitivity to output amplifier offset.

This very versatile DAC is useful for 2-quadrant and 4-quadrant multiplying, programmable gain and filtering and single supply noninverting voltage output operation.

Parts are available in 20-pin PDIP and SO packages and commercial and industrial temperature grades.

 LTC and LT are registered trademarks of Linear Technology Corporation.

TYPICAL APPLICATION

2-Quadrant Multiplying DAC Has Less Than 0.5LSB (Typ) Total Unadjusted Error

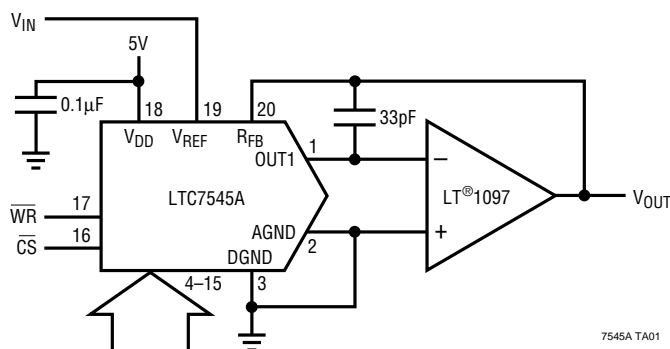

Integral Nonlinearity Over Temperature

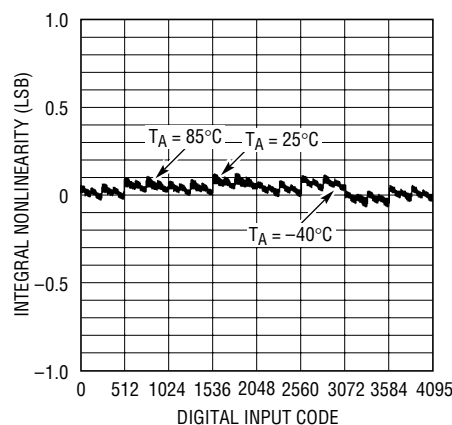

ABSOLUTE MAXIMUM RATINGS

V_{DD} to AGND	-0.5V to 17V
V_{DD} to DGND	-0.5V to 17V
AGND to DGND	-0.5V to $V_{DD} + 0.5V$
DGND to AGND	-0.5V to $V_{DD} + 0.5V$
V_{REF} to AGND,DGND	$\pm 25V$
R_{FB} to AGND,DGND	$\pm 25V$
Digital Inputs to DGND	-0.5V to $V_{DD} + 0.5V$
V_{OUT1} to AGND, DGND	-0.5V to $V_{DD} + 0.5V$
Maximum Junction Temperature	150°C
Operating Temperature Range	
Commercial (K, L Versions)	0°C to 70°C
Industrial (B, C Versions).....	-40°C to 85°C
Storage Temperature Range	-65°C to 150°C
Lead Temperature (Soldering, 10 sec).....	300°C

PACKAGE/ORDER INFORMATION

TOP VIEW		ORDER PART NUMBER
OUT1 [1]	[20] R_{FB}	LTC7545ABG
AGND [2]	[19] V_{REF}	LTC7545ABN
DGND [3]	[18] V_{DD}	LTC7545ABSW
DB11 (MSB) [4]	[17] \overline{WR}	LTC7545ACG
DB10 [5]	[16] \overline{CS}	LTC7545ACN
DB9 [6]	[15] DB0 (LSB)	LTC7545ACSW
DB8 [7]	[14] DB1	LTC7545AKG
DB7 [8]	[13] DB2	LTC7545AKN
DB6 [9]	[12] DB3	LTC7545AKSW
DB5 [10]	[11] DB4	LTC7545ALG
		LTC7545ALN
		LTC7545ALSW

G PACKAGE N PACKAGE
 20-LEAD PLASTIC SSOP 20-LEAD PDIP
 SW PACKAGE
 20-LEAD PLASTIC SO WIDE

$T_{JMAX} = XXX^{\circ}C, \theta_{JA} = XXX^{\circ}C/W$ (G)
 $T_{JMAX} = 150^{\circ}C, \theta_{JA} = 100^{\circ}C/W$ (N)
 $T_{JMAX} = 150^{\circ}C, \theta_{JA} = 130^{\circ}C/W$ (SW)

Consult factory for Military grade parts.

ELECTRICAL CHARACTERISTICS

$V_{DD} = 5V$ or $15V$, $V_{REF} = 10V$, $V_{OUT1} = AGND = 0V$, $T_A = T_{MIN}$ to T_{MAX} , unless otherwise noted.

SYMBOL	PARAMETER	CONDITIONS	LTC7545AK/AB			LTC7545AL/AC			UNITS	
			MIN	TYP	MAX	MIN	TYP	MAX		
Accuracy										
	Resolution		●	12		12			Bits	
INL	Integral Nonlinearity (Relative Accuracy)	(Note 1) $T_A = 25^{\circ}C$ T_{MIN} to T_{MAX}	●		± 0.5		± 0.5		LSB	
			●		± 0.5		± 0.5		LSB	
DNL	Differential Nonlinearity	Guaranteed Monotonic T_{MIN} to T_{MAX}	●		± 1		± 0.5		LSB	
			●		± 1		± 0.5		LSB	
GE	Gain Error	(Note 2) $T_A = 25^{\circ}C$ T_{MIN} to T_{MAX}	●		± 2		± 1		LSB	
			●		± 3		± 2		LSB	
	Gain Temperature Coefficient	(Note 3) $\Delta Gain/\Delta Temperature$	●	1	5		1	5	ppm/ $^{\circ}C$	
I_{LKG}	OUT1 Leakage Current	(Note 4) $T_A = 25^{\circ}C$ T_{MIN} to T_{MAX}	●		± 10		± 10		nA	
			●		± 50		± 50		nA	
PSRR	Power Supply Rejection		●		± 0.002		± 0.002		%/%	
Reference Input										
R_{REF}	V_{REF} Input Resistance	(Note 5)	●	8	11	15	8	11	15	k Ω
AC Performance										
	Output Current Settling Time	(Notes 3, 6, 7)	●		1		1		μs	
	Propagation Delay	(Notes 3, 6, 8)	●		150		150		ns	
	Digital-to-Analog Glitch Impulse	(Notes 6, 9)	●		5		5		nV-sec	
	Multiplying Feedthrough Error	$V_{REF} = \pm 10V$, 10kHz Sine Wave	●		5		5		mV _{p-p}	
Analog Outputs										
C_{OUT}	Output Capacitance (Note 3)	DB0 to DB11 = 0V, \overline{WR} , \overline{CS} = 0V	●	30	70		30	70	pF	
		DB0 to DB11 = V_{DD} , \overline{WR} , \overline{CS} = 0V	●	60	150		60	150	pF	

ELECTRICAL CHARACTERISTICS

$V_{DD} = 5V$, $V_{REF} = 10V$, $V_{OUT1} = AGND = 0V$, $T_A = T_{MIN}$ to T_{MAX} , unless otherwise noted.

SYMBOL	PARAMETER	CONDITIONS	ALL GRADES			UNITS	
			MIN	TYP	MAX		
Digital Inputs							
V_{IH}	Digital Input High Voltage		●	2.4		V	
V_{IL}	Digital Input Low Voltage		●		0.8	V	
I_{IN}	Digital Input Current		●	0.001	±1	μA	
C_{IN}	Digital Input Capacitance	(Note 3) $V_{IN} = 0V$	●		8	pF	
Timing Characteristics (Note 3)							
t_{CS}	\overline{CS} to \overline{WR} Setup Time		●	100		ns	
t_{CH}	\overline{CS} to \overline{WR} Hold Time		●	0		ns	
t_{WR}	Write Pulse Width		●	100		ns	
t_{DS}	Data Setup Time		●	100		ns	
t_{DH}	Data Hold Time		●	5		ns	
Power Supply							
V_{DD}	Supply Voltage		●	4.75	5	5.25	V
I_{DD}	Supply Current	All Digital Inputs = V_{IH} or V_{IL} All Digital Inputs = $0V$ or V_{DD}	● ●		2 100		mA μA

$V_{DD} = 15V$, $V_{REF} = 10V$, $V_{OUT1} = AGND = 0V$, $T_A = T_{MIN}$ to T_{MAX} , unless otherwise noted.

SYMBOL	PARAMETER	CONDITIONS	ALL GRADES			UNITS	
			MIN	TYP	MAX		
Digital Inputs							
V_{IH}	Digital Input High Voltage		●	13.5		V	
V_{IL}	Digital Input Low Voltage		●		1.5	V	
I_{IN}	Digital Input Current		●		±1	μA	
C_{IN}	Digital Input Capacitance	(Note 3) $V_{IN} = 0V$	●		8	pF	
Timing Characteristics (Note 3)							
t_{CS}	\overline{CS} to \overline{WR} Setup Time		●	75		ns	
t_{CH}	\overline{CS} to \overline{WR} Hold Time		●	0		ns	
t_{WR}	Write Pulse Width		●	75		ns	
t_{DS}	Data Setup Time		●	60		ns	
t_{DH}	Data Hold Time		●	5		ns	
Power Supply							
V_{DD}	Supply Voltage		●	14.25	15	15.75	V
I_{DD}	Supply Current	All Digital Inputs = V_{IH} or V_{IL} All Digital Inputs = $0V$ or V_{DD}	● ●		2 100		mA μA

The ● denotes specifications which apply over the full operating temperature range.

Note 1: $\pm 0.5LSB = \pm 0.012\%$ of full scale.

Note 2: Using internal feedback resistor.

Note 3: Guaranteed by design, not subject to test.

Note 4: I_{OUT1} with DAC register loaded to all 0s.

Note 5: Typical temperature coefficient is 100ppm/°C.

Note 6: $OUT1$ load = 100Ω in parallel with 13pF.

Note 7: To 0.01% for a full-scale change, measured from the falling edge of WR , $CS = 0V$.

Note 8: From digital input change to 90% of final analog output.

Note 9: $V_{REF} = 0V$. DAC register contents changed from all 0s to all 1s or all 1s to all 0s.

BLOCK DIAGRAM

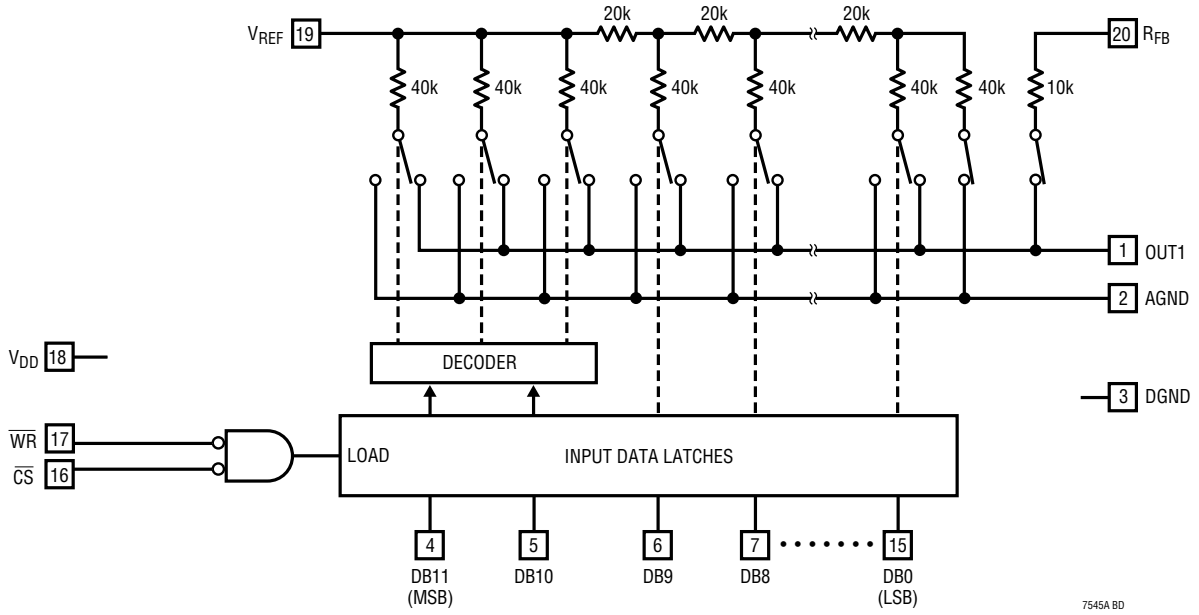

TIMING DIAGRAM

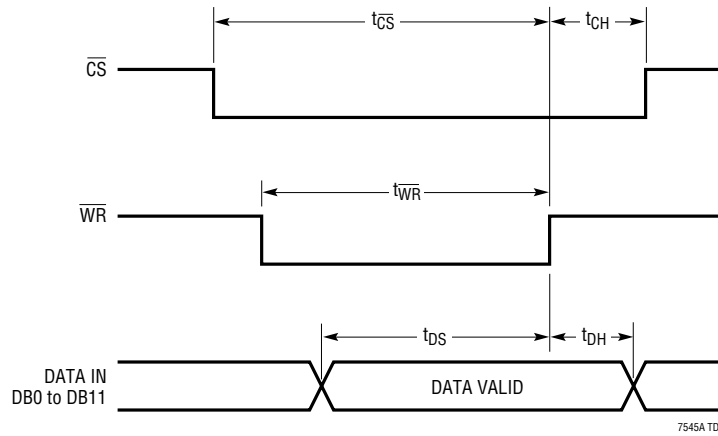

TYPICAL APPLICATIONS

Unipolar Operation (2-Quadrant Multiplication)

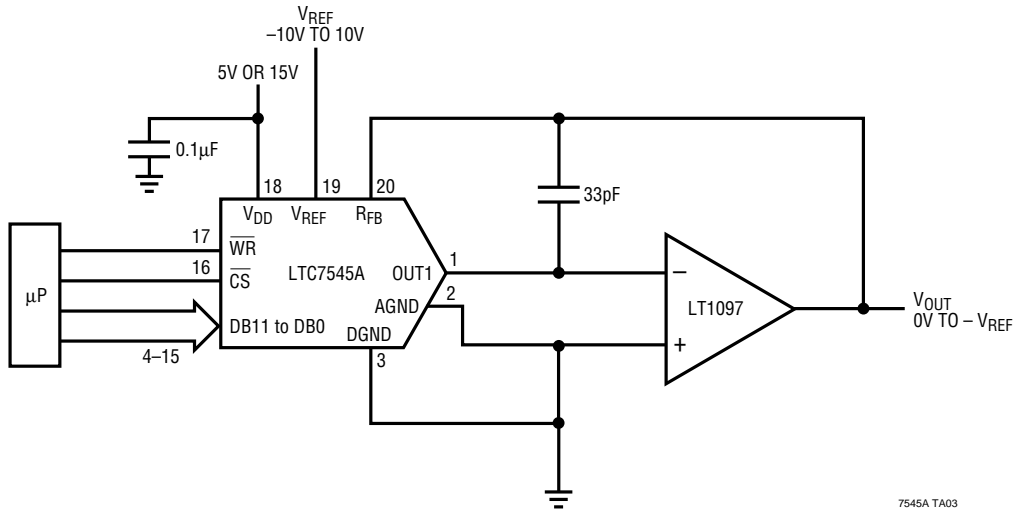

7545A TA03

Table 1. Unipolar Binary Code Table

DIGITAL INPUT BINARY NUMBER IN DAC LATCH			ANALOG OUTPUT V_{OUT}
MSB		LSB	
1111	1111	1111	$-V_{REF}$ (4095/4096)
1000	0000	0000	$-V_{REF}$ (2048/4096) = $-V_{REF}/2$
0000	0000	0001	$-V_{REF}$ (1/4096)
0000	0000	0000	0V

TYPICAL APPLICATIONS

Bipolar Operation (4-Quadrant Multiplication)

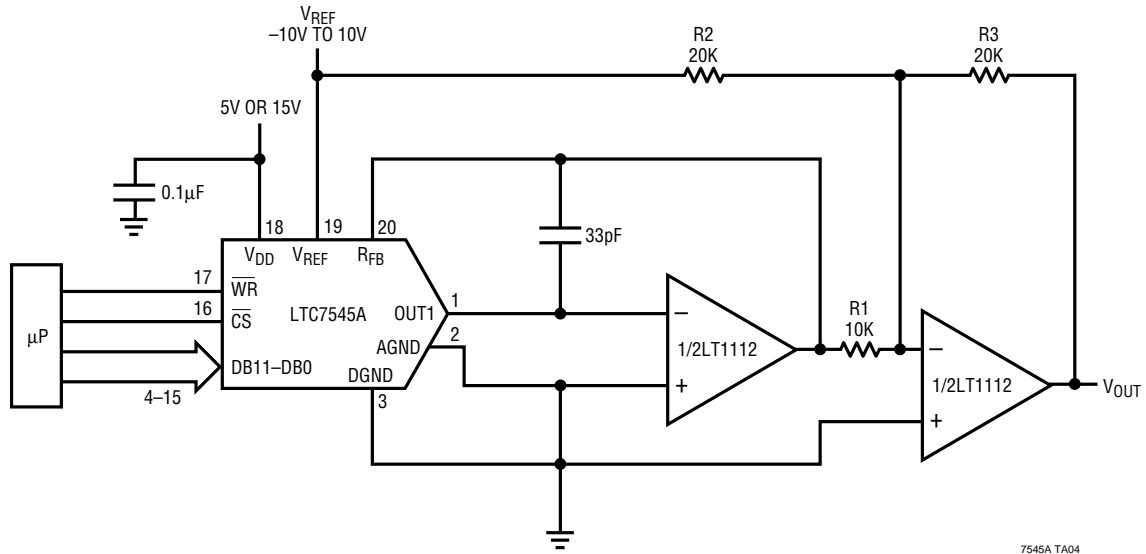

7545A TA04

Table 2. Bipolar Offset Binary Code Table

DIGITAL INPUT BINARY NUMBER IN DAC LATCH			ANALOG OUTPUT V_{OUT}
MSB		LSB	
1111	1111	1111	V_{REF} (2047/2048)
1000	0000	0001	V_{REF} (1/2048)
1000	0000	0000	0V
0111	1111	1111	$-V_{REF}$ (1/2048)
0000	0000	0000	$-V_{REF}$ (2048/2048) = $-V_{REF}$

PACKAGE DESCRIPTION Dimensions in inches (millimeters) unless otherwise noted.

G Package
20-Lead Plastic SSOP (0.209)
 (LTC DWG # 05-08-1640)

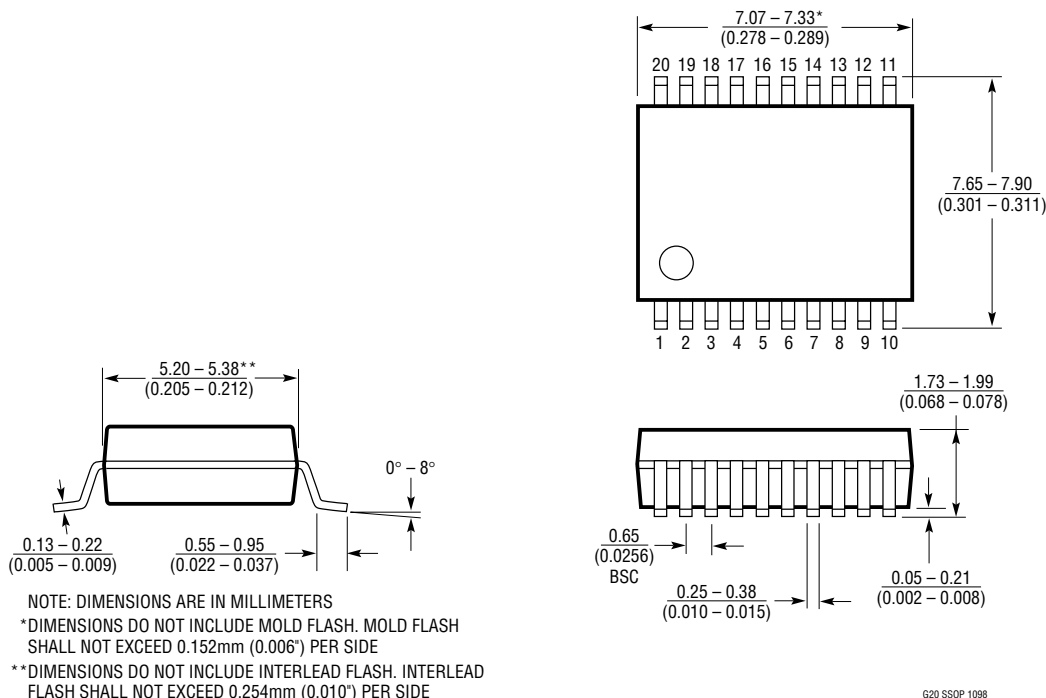

N Package
20-Lead PDIP (Narrow 0.300)
 (LTC DWG # 05-08-1510)

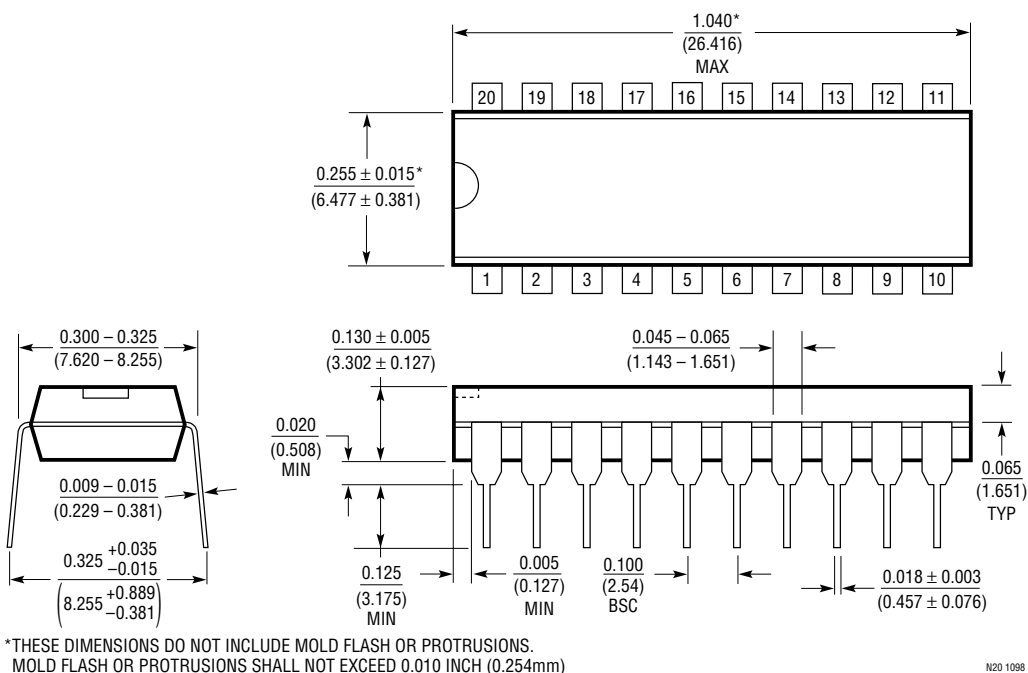

PACKAGE DESCRIPTION Dimensions in inches (millimeters) unless otherwise noted.

SW Package
20-Lead Plastic Small Outline (Wide 0.300)
 (LTC DWG # 05-08-1620)

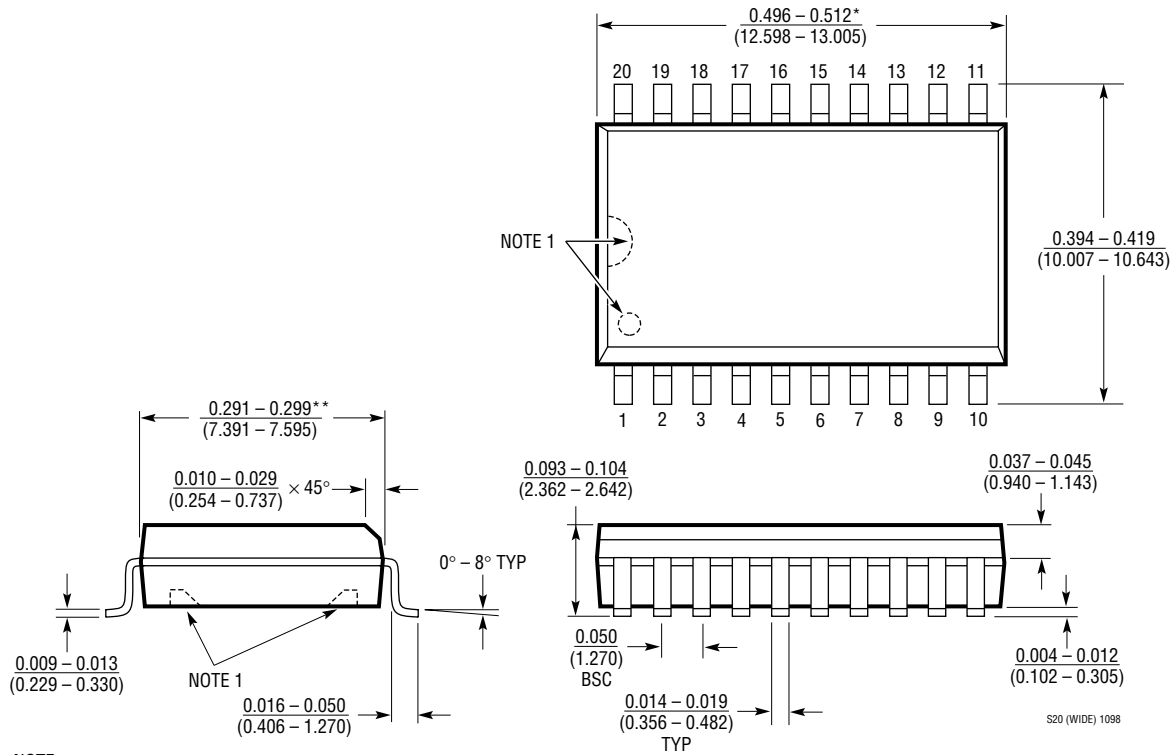

NOTE:
 1. PIN 1 IDENT, NOTCH ON TOP AND CAVITIES ON THE BOTTOM OF PACKAGES ARE THE MANUFACTURING OPTIONS.
 THE PART MAY BE SUPPLIED WITH OR WITHOUT ANY OF THE OPTIONS
 *DIMENSION DOES NOT INCLUDE MOLD FLASH. MOLD FLASH SHALL NOT EXCEED 0.006" (0.152mm) PER SIDE
 **DIMENSION DOES NOT INCLUDE INTERLEAD FLASH. INTERLEAD FLASH SHALL NOT EXCEED 0.010" (0.254mm) PER SIDE

RELATED PARTS

PART NUMBER	DESCRIPTON	COMMENTS
LTC1257	Complete Serial I/O V _{OUT} 12-Bit DAC	5V to 15V Single Supply in 8-Pin SO and PDIP
LTC1450/LTC1450L	Complete Parallel Input V _{OUT} 12-Bit DACs	Rail-to-Rail V _{OUT} , 3V/5V Single Supply, 12-Bit or (8 + 4) Bit Loading
LTC1451/LTC1452/LTC1453	Complete Serial I/O V _{OUT} 12-Bit DACs	Rail-to-Rail V _{OUT} , 3V/5V Single Supply in 8-Pin SO and PDIP
LTC7541A	Parallel I/O Multiplying I _{OUT} 12-Bit DAC	12-Bit Wide Parallel Input
LTC7543/LTC8143	Serial I/O Multiplying I _{OUT} 12-Bit DACs	Clear Pin and Serial Data Output (LTC8143)
LTC8043	Serial I/O Multiplying I _{OUT} 12-Bit DAC	8-Pin SO and PDIP