

## FEATURES

- Trimmed Output  $\pm 0.3\%$
- Low Drift— $5\text{ppm}/^\circ\text{C}$  Typ
- Low Noise— $3\text{ppm}_{(P-P)}$
- High Line Rejection
- Temperature Output—REF-02
- Low Supply Current 1.4mA Max

## APPLICATIONS

- A/D and D/A Converters
- Precision Regulators
- Constant Current Sources
- V/F Converters
- Bridge Excitation

## DESCRIPTION

The REF-01/REF-02 are precision 10V and 5V bandgap references which provide stable output voltages over a wide range of operating conditions. Output voltage is accurate to  $\pm 0.3\%$  with a low  $5\text{ppm}/^\circ\text{C}$  typical temperature coefficient. The REF-01 and REF-02 are excellent choices for applications where low drift, moderate accuracy, low power consumption and low cost are considerations.

The REF-02 includes a temperature output pin which provides a linear voltage proportional to absolute temperature.

For lower drift and higher accuracy references, please see the LT1019 and LT1021 data sheets.

LT, LT, LTC and LTM are registered trademarks of Linear Technology Corporation. All other trademarks are the property of their respective owners.

## TYPICAL APPLICATION

Ultra Linear Strain Gauge Amplifier

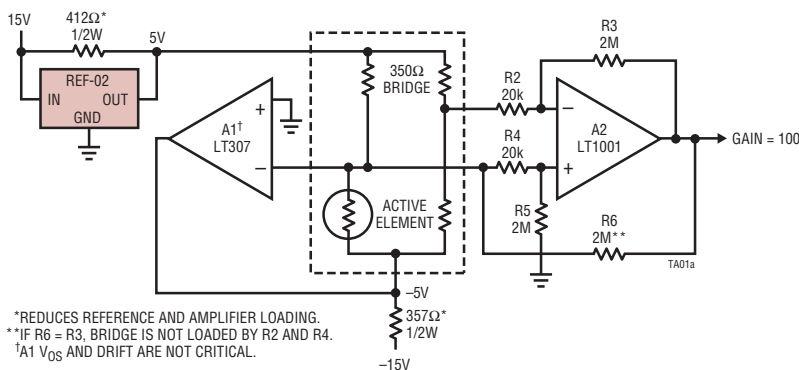

Output Voltage Temperature Drift

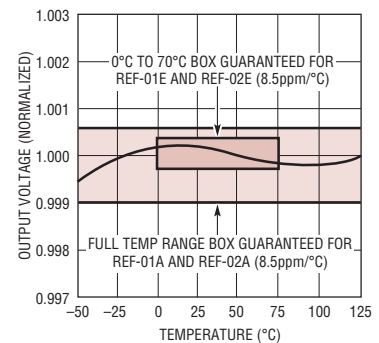

# REF-01/REF-02

## ABSOLUTE MAXIMUM RATINGS

REF-01/REF-02 A, E, H .....	40V
REF-01C/REF-02C.....	30V
Power Dissipation .....	500mW
Output Short-Circuit Duration	
To Ground.....	Indefinite
To $V_{IN} \leq 16V$ .....	Indefinite
To $V_{IN} > 16V$ .....	Not Allowed

Storage Temperature Range .....	-65°C to 150°C
Operating Temperature	
REF-01/REF-02, REF-01A/REF-02A... ..	-55°C to 125°C
REF-01E/REF-02E, REF-01H/REF-02H,	
REF-01C/REF-02C, REF-01D/REF-02D ....	0°C to 70°C
Lead Temperature (Soldering, 10 sec).....	300°C

## PIN CONFIGURATION

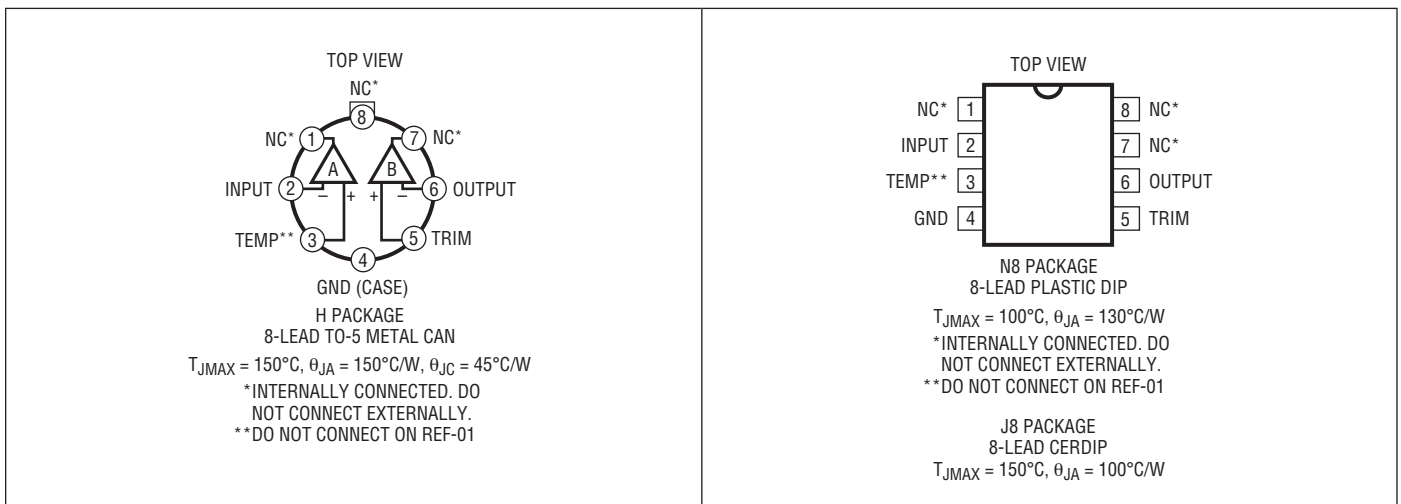

## ORDER INFORMATION

LEAD FREE FINISH	PART MARKING	PACKAGE DESCRIPTION	TEMPERATURE RANGE
REF01EN8#PBF	REF01EN8	8-Lead Plastic Dip	0°C to 70°C
REF01HN8#PBF	REF01HN8	8-Lead Plastic Dip	0°C to 70°C
REF01CN8#PBF	REF01CN8	8-Lead Plastic Dip	0°C to 70°C
REF02EN8#PBF	REF02EN8	8-Lead Plastic Dip	0°C to 70°C
REF02HN8#PBF	REF02HN8	8-Lead Plastic Dip	0°C to 70°C
REF02CN8#PBF	REF02CN8	8-Lead Plastic Dip	0°C to 70°C
REF02DN8#PBF	REF02DN8	8-Lead Plastic Dip	0°C to 70°C
REF01AH#PBF		8-Lead TO-5 Metal Can	-55°C to 125°C
REF01H#PBF		8-Lead TO-5 Metal Can	-55°C to 125°C
REF01EH#PBF		8-Lead TO-5 Metal Can	0°C to 70°C
REF01HH#PBF		8-Lead TO-5 Metal Can	0°C to 70°C
REF01CH#PBF		8-Lead TO-5 Metal Can	0°C to 70°C
REF02H#PBF		8-Lead TO-5 Metal Can	-55°C to 125°C
REF02EH#PBF		8-Lead TO-5 Metal Can	0°C to 70°C
REF02HH#PBF		8-Lead TO-5 Metal Can	0°C to 70°C
REF02CH#PBF		8-Lead TO-5 Metal Can	0°C to 70°C

ref012fd

## ORDER INFORMATION

LEAD FREE FINISH	PART MARKING	PACKAGE DESCRIPTION	TEMPERATURE RANGE
REF02DH#PBF		8-Lead TO-5 Metal Can	0°C to 70°C
REF01EJ8#PBF		8-Lead Cerdip	0°C to 70°C
REF01HJ8#PBF		8-Lead Cerdip	0°C to 70°C
REF01CJ8#PBF		8-Lead Cerdip	0°C to 70°C
REF02EJ8#PBF		8-Lead Cerdip	0°C to 70°C
REF02HJ8#PBF		8-Lead Cerdip	0°C to 70°C
REF02CJ8#PBF		8-Lead Cerdip	0°C to 70°C
REF02DJ8#PBF		8-Lead Cerdip	0°C to 70°C
<b>OBsolete</b> Consider the N Package for Alternate Source			
LEAD BASED FINISH	PART MARKING	PACKAGE DESCRIPTION	TEMPERATURE RANGE
REF02AH	REF02AH	8-Lead TO-5 Metal Can	-55°C to 125°C
REF02AJ8	REF02AJ8	8-Lead Cerdip	-55°C to 125°C

Consult LTC Marketing for parts specified with wider operating temperature ranges.

For more information on lead free part marking, go to: <http://www.linear.com/leadfree/>

For more information on tape and reel specifications, go to: <http://www.linear.com/tapeandree/>

## ELECTRICAL CHARACTERISTICS $V_{IN} = 15V, T_A = 25^\circ C$ unless otherwise noted.

SYMBOL	PARAMETER	CONDITIONS	REF-01A/E, REF-02A/E			REF-01H, REF-02H			UNITS	
			MIN	TYP	MAX	MIN	TYP	MAX		
$V_O$	Output Voltage	$I_L = 0mA$	REF-01 REF-02	9.97 4.985	10 5	10.03 5.015	9.95 4.975	10 5	10.05 5.025	V V
	Output Adjustment Range	$R_p = 10k\Omega$	REF-01 REF-02	$\pm 3$ $\pm 3$	5, -27 5, -13		$\pm 3$ $\pm 3$	5, -27 5, -13		% %
$e_{n-P-P}$	Output Voltage Noise	0.1Hz to 10Hz (Note 7)	REF-01 REF-02		20 10			20 10		$\mu V_{P-P}$ $\mu V_{P-P}$
$V_{IN}$	Input Voltage Range		REF-01	12		40	12		40	V V
			REF-02	7		40	7		40	
$\frac{\Delta V_{OUT}}{\Delta V_{IN}}$	Line Regulation (Note 2)	$(V_{OUT} + 3V) \leq V_{IN} \leq 33V$			0.0001	0.01		0.0001	0.01	%/V
$\frac{\Delta V_{OUT}}{\Delta I_{OUT}}$	Load Regulation (Note 2)	$I_L = 0mA$ to 10mA	REF-01		0.0005	0.008		0.0005	0.01	%/mA
			REF-02		0.001	0.01		0.001	0.01	%/mA
$I_Q$	Quiescent Supply Current	No Load			0.65	1.4		0.65	1.4	mA
$I_{OUT}$	Load Current Sink Current			10	20		10	20		mA
				-0.3	-20		-0.3	-20		mA
$I_{SC}$	Short-Circuit Current	$V_O = 0V$			25			25		mA
$V_T$	Temperature Voltage Output (Note 3)		REF-02 Only		620			620		mV

$V_{IN} = 15V, T_A = 25^\circ C$  unless otherwise noted.

SYMBOL	PARAMETER	CONDITIONS	REF-01C, REF-02C			REF-02D			UNITS	
			MIN	TYP	MAX	MIN	TYP	MAX		
$V_O$	Output Voltage	$I_L = 0mA$	REF-01 REF-02	9.9 4.95	10 5	10.1 5.05	4.9	5	5.1	V V
	Output Adjustment Range	$R_p = 10k\Omega$	REF-01 REF-02	$\pm 2.7$	5, -27 5, -13		$\pm 2$	5, -13		% %
$e_{n-P-P}$	Output Voltage Noise	0.1Hz to 10Hz (Note 7)	REF-01 REF-02		30 12			12		$\mu V_{P-P}$ $\mu V_{P-P}$

ref012fd

**ELECTRICAL CHARACTERISTICS**  $V_{IN} = 15V$ ,  $T_A = 25^\circ C$  unless otherwise noted.

SYMBOL	PARAMETER	CONDITIONS	REF-01C, REF-02C			REF-02D			UNITS
			MIN	TYP	MAX	MIN	TYP	MAX	
$\frac{\Delta V_{OUT}}{\Delta V_{IN}}$	Line Regulation (Note 2)	$(V_{OUT} + 3V) \leq V_{IN} \leq 33V$		0.0001	0.015		0.0001	0.04	%/V
$\frac{\Delta V_{OUT}}{\Delta I_{OUT}}$	Load Regulation (Note 2)	$I_L = 0mA$ to 8mA $I_L = 0mA$ to 4mA		0.0005	0.015		0.001	0.04	%/mA %/mA
$I_Q$	Quiescent Supply Current	No Load		0.65	1.6		0.65	2	mA
$I_{OUT}$	Load Current Sink Current		8 -0.2	20 20		8 -0.2	20 20		mA mA
$I_{SC}$	Short-Circuit Current	$V_O = 0V$		25			25		mA
$V_T$	Temperature Voltage Output	(Note 3) REF-02 Only		620			620		mV

The ● denotes the specifications which apply over the full operating temperature range, otherwise specifications are at  $T_A = 25^\circ C$ .  
 $V_{IN} = 15V$ ,  $-55^\circ C \leq T_A \leq \pm 125^\circ C$  for REF-01A/REF-02A and REF-01/REF-02,  $0^\circ C \leq T_A \leq 70^\circ C$  for REF-01E/REF-02E and  
REF-01H/REF-02H,  $I_L = 0mA$  unless otherwise noted.

SYMBOL	PARAMETER	CONDITIONS		REF-01A/E, REF-02A/E			REF-01H/ REF-02H			UNITS
				MIN	TYP	MAX	MIN	TYP	MAX	
$\frac{\Delta V}{\Delta T}$	Output Voltage Change With Temperature (Notes 4, 5)	$0^\circ C \leq T_A \leq 70^\circ C$	●		0.02	0.06		0.035	0.17	%
		$-55^\circ C \leq T_A \leq 125^\circ C$	●		0.09	0.15		0.144	0.45	%
TC	Output Voltage Temperature Coefficient	(Note 6)	●		5	8.5		8	25	ppm/ $^\circ C$
		Change in $V_O$ Temperature Coefficient With Output Adjustment	$R_P = 10k\Omega$	●		0.5		0.5		ppm/%
$\frac{\Delta V_{OUT}}{\Delta V_{IN}}$	Line Regulation $(V_{OUT} + 3V) \leq V_{IN} \leq 33V$ (Note 2)	$0^\circ C \leq T_A \leq 70^\circ C$	●		0.0001	0.012		0.0001	0.012	%/V
		$-55^\circ C \leq T_A \leq 125^\circ C$	●		0.0001	0.015		0.0001	0.015	%/V
$\frac{\Delta V_{OUT}}{\Delta I_{OUT}}$	Load Regulation ( $I_L = 0mA$ to 8mA) (Note 2)	$0^\circ C \leq T_A \leq 70^\circ C$	●		0.002	0.01		0.002	0.012	%/mA
		$-55^\circ C \leq T_A \leq 125^\circ C$	●		0.002	0.012		0.002	0.015	%/mA
	Temperature Voltage Output Temperature Coefficient	(Note 3) REF-02	●		2.1			2.1		mV/ $^\circ C$

The ● denotes the specifications which apply over the full operating temperature range, otherwise specifications are at  $T_A = 25^\circ C$ .  
 $V_{IN} = 15V$ ,  $0^\circ C \leq T_A \leq 70^\circ C$  and  $I_L = 0mA$  unless otherwise noted.

SYMBOL	PARAMETER	CONDITIONS		REF-01C, REF-02C			REF-02D			UNITS
				MIN	TYP	MAX	MIN	TYP	MAX	
$\frac{\Delta V}{\Delta T}$	Output Voltage Change With Temperature	(Notes 4, 5)	●			0.45			1.7	%
TC	Output Voltage Temperature Coefficient	(Note 6)	●		8	65		8	250	ppm/ $^\circ C$
		Change in $V_O$ Temperature Coefficient With Output Adjustment	$R_P = 10k\Omega$	●		0.5		0.5		ppm/%
$\frac{\Delta V_{OUT}}{\Delta V_{IN}}$	Line Regulation (Note 2)	$V_{IN} = 8V$ to 30V	●		0.0001	0.018		0.0001	0.05	%/V
$\frac{\Delta V_{OUT}}{\Delta I_{OUT}}$	Load Regulation (Note 2)	$I_L = 0mA$ to 5mA	●		0.002	0.018		0.002	0.05	%/mA
		Temperature Voltage Output Temperature Coefficient	(Note 3) REF-02	●		2.1			2.1	

## ELECTRICAL CHARACTERISTICS

**Note 1:** Stresses beyond those listed under Absolute Maximum Ratings may cause permanent damage to the device. Exposure to any Absolute Maximum Rating condition for extended periods may affect device reliability and lifetime.

**Note 2:** Line and load regulation specifications include the effect of self heating.

**Note 3:** Limit current in or out of Pin 3 to 50nA and capacitance on Pin 3 to 30pF.

**Note 4:**  $\Delta V$  is defined as the absolute difference between the maximum output voltage and the minimum output voltage over the specified temperature range expressed as a percentage of nominal output.

$$\Delta V = \left| \frac{V_{MAX} - V_{MIN}}{V_{OUT}} \right| \cdot 100$$

**Note 5:**  $\Delta V$  specification applies trimmed or untrimmed.

**Note 6:** TC is defined as  $\Delta V$  divided by the temperature range, i.e.,

$$TC = \frac{\Delta V}{T_{MAX} - T_{MIN}}$$

**Note 7:** 0.1Hz to 10Hz noise cannot be 100% tested on modern high speed test equipment, so Linear Technology does not put a guaranteed maximum specification on this parameter for standard units. 100% bench testing of 0.1Hz to 10Hz noise is available on special request. To ensure low output noise, Linear Technology *does* 100% test 10Hz to 1kHz noise. Consult factory for details.

## PACKAGE DESCRIPTION

**H Package**  
**8-Lead TO-5 Metal Can (.230 Inch PCD)**  
 (Reference LTC DWG # 05-08-1321)

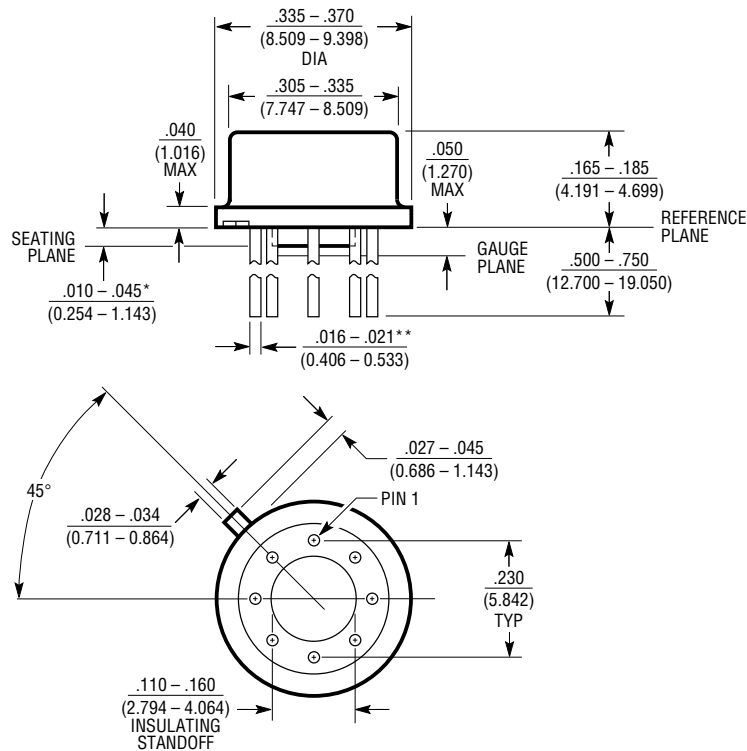

\*LEAD DIAMETER IS UNCONTROLLED BETWEEN THE REFERENCE PLANE AND THE SEATING PLANE

\*\* FOR SOLDER DIP LEAD FINISH, LEAD DIAMETER IS  $\frac{.016 - .024}{(0.406 - 0.610)}$  H8 (TO-5) 0.230 PCD 0204

**PACKAGE DESCRIPTION**

**J8 Package**  
**8-Lead CERDIP (Narrow .300 Inch, Hermetic)**  
 (Reference LTC DWG # 05-08-1110)

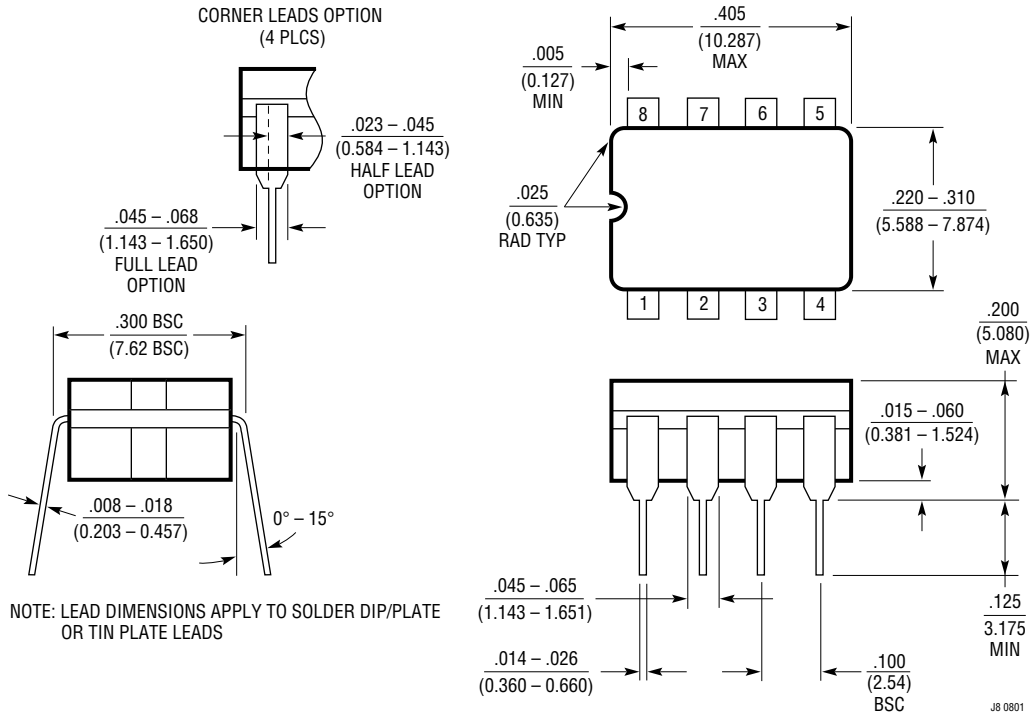

## PACKAGE DESCRIPTION

### N8 Package 8-Lead PDIP (Narrow .300 Inch) (Reference LTC DWG # 05-08-1510)

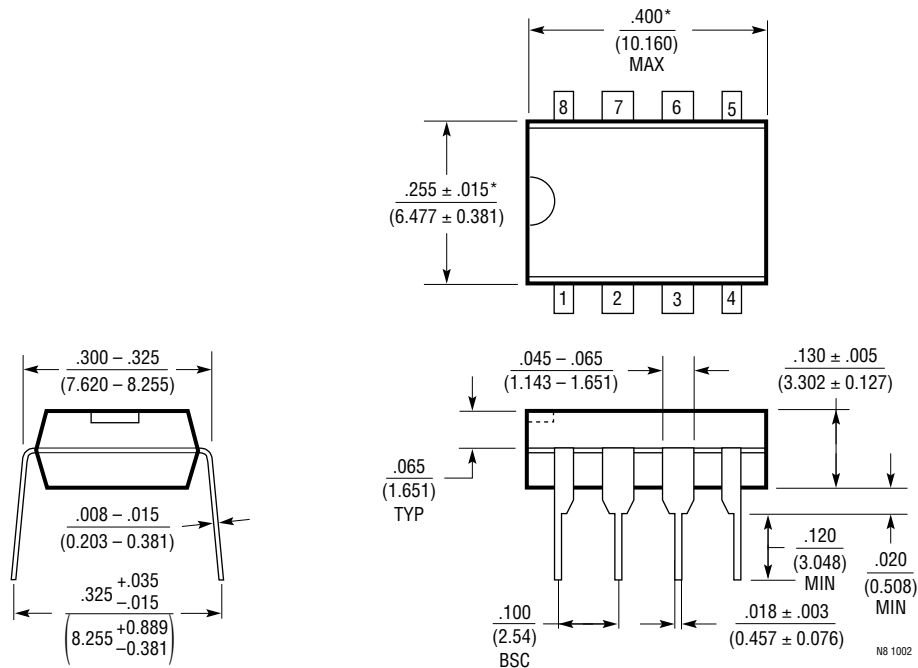

#### NOTE:

1. DIMENSIONS ARE  $\frac{\text{INCHES}}{\text{MILLIMETERS}}$

\*THESE DIMENSIONS DO NOT INCLUDE MOLD FLASH OR PROTRUSIONS.  
MOLD FLASH OR PROTRUSIONS SHALL NOT EXCEED .010 INCH (0.254mm)

# REF-01/REF-02

---

## RELATED PARTS

PART NUMBER	DESCRIPTION	COMMENTS
LT1019	0.05%, 5ppm/°C Precision Reference	Pin Compatible With the REF-01, REF-02, Improved Specs

