

### FEATURES

- 2-Channel Ideal Diode OR'ing or Load Sharing
- Low Loss Replacement for PowerPath™ OR'ing Diodes
- Fast Response Replacement for LTC4413
- Low Forward On-Resistance (140mΩ Max at 3.6V)
- Low Reverse Leakage Current
- Low Regulated Forward Voltage (18mV Typ)
- Overvoltage Protection Sensor with Drive Output for an External P-Channel MOSFET (LTC4413-2 Only)
- 2.5V to 5.5V Operating Range
- 2.6A Maximum Forward Current
- Internal Current Limit Protection
- Internal Thermal Protection
- Status Output to Indicate if Selected Channel is Conducting
- Programmable Channel On/Off
- Low Profile (0.75mm) 10-Lead 3mm × 3mm DFN Package

### APPLICATIONS

- Battery and Wall Adapter Diode OR'ing in Handheld Products
- Backup Battery Diode OR'ing
- Power Switching
- USB Peripherals
- Uninterruptable Supplies

### DESCRIPTION

The LTC®4413-1 and LTC4413-2 each contain two monolithic ideal diodes, each capable of supplying up to 2.6A from input voltages between 2.5V and 5.5V. The ideal diodes use a 100mΩ P-channel MOSFET to independently connect INA to OUTA and INB to OUTB. During normal forward operation, the voltage drops across each of these diodes are regulated to as low as 18mV. Quiescent current is less than 80μA for diode currents up to 1A. If either of the output voltages exceeds its respective input voltage, that MOSFET is turned off and less than 1μA of reverse current flows from OUT to IN. Maximum forward current in each MOSFET is limited to a constant 2.6A and internal thermal limiting circuits protect the part during fault conditions. An internal overvoltage protection sensor detects when a voltage exceeds the LTC4413-2 absolute maximum voltage tolerance.

Two active-high control pins independently turn off the two ideal diodes contained within the LTC4413-1/LTC4413-2. When the selected channel is reverse biased, or the LTC4413-1/LTC4413-2 is put into low power standby, the status signal is pulled low by an 11μA open drain.

The LTC4413-1/LTC4413-2 are housed in a 10-lead 3mm × 3mm DFN package.

LT, LT, LTC, LTM, Linear Technology and the Linear logo are registered trademarks of Linear Technology Corporation. PowerPath is a trademark of Linear Technology Corporation. All other trademarks are the property of their respective owners.

### TYPICAL APPLICATION

Automatic Switchover from a Battery to a Wall Adapter

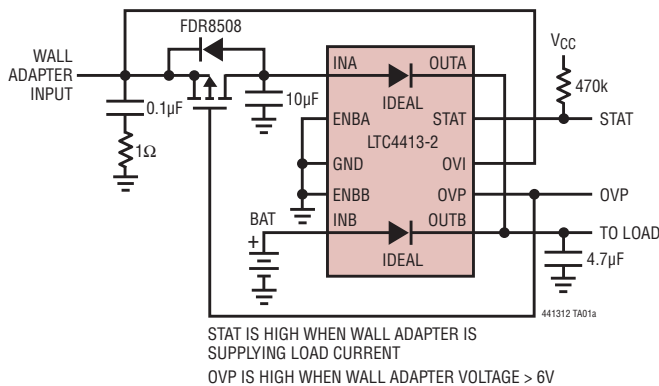

Power Loss vs Load

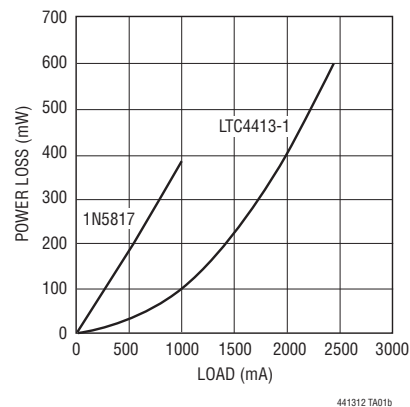

441312fd

# LTC4413-1/LTC4413-2

## ABSOLUTE MAXIMUM RATINGS (Note 1)

INA, INB, OUTA, OUTB, STAT,	Storage Temperature Range .....	-65°C to 125°C
ENBA, ENBB Voltage .....	Continuous Power Dissipation .....	1500mW
OVI, OVP Voltage .....	(Derate 25mW/°C Above 70°C)	
Operating Temperature Range .....		-40°C to 85°C

## PIN CONFIGURATION

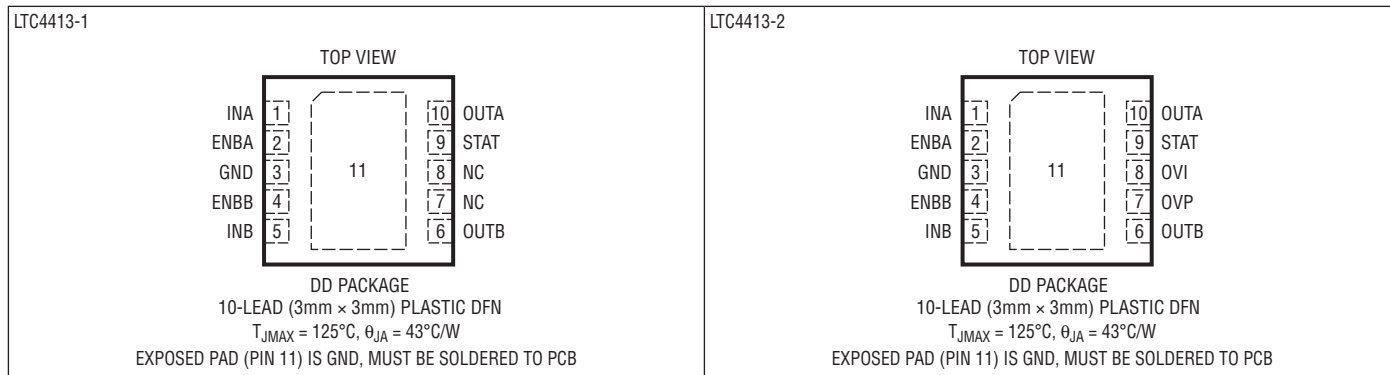

## ORDER INFORMATION

LEAD FREE FINISH	TAPE AND REEL	PART MARKING	PACKAGE DESCRIPTION	TEMPERATURE RANGE
LTC4413EDD-1#PBF	LTC4413EDD-1#TRPBF	LCPP	10-Lead (3mm × 3mm) Plastic DFN	-40°C to 85°C
LTC4413EDD-2#PBF	LTC4413EDD-2#TRPBF	LCPQ	10-Lead (3mm × 3mm) Plastic DFN	-40°C to 85°C
LEAD BASED FINISH	TAPE AND REEL	PART MARKING	PACKAGE DESCRIPTION	TEMPERATURE RANGE
LTC4413EDD-1	LTC4413EDD-1#TR	LCPP	10-Lead (3mm × 3mm) Plastic DFN	-40°C to 85°C
LTC4413EDD-2	LTC4413EDD-2#TR	LCPQ	10-Lead (3mm × 3mm) Plastic DFN	-40°C to 85°C

Consult LTC Marketing for parts specified with wider operating temperature ranges.

For more information on lead free part marking, go to: <http://www.linear.com/leadfree/>

For more information on tape and reel specifications, go to: <http://www.linear.com/tapeandreel/>

## ELECTRICAL CHARACTERISTICS

The ● denotes the specifications which apply over the full operating temperature range, otherwise specifications are at T<sub>A</sub> = 25°C. (Notes 2, 6)

SYMBOL	PARAMETER	CONDITIONS	MIN	TYP	MAX	UNITS	
V <sub>IN</sub> , V <sub>OUT</sub>	Operating Supply Range for Channel A or B	V <sub>IN</sub> and/or V <sub>OUT</sub> Must be in This Range for Proper Operation	●	2.5	5.5	V	
UVLO	UVLO Turn-On Rising Threshold	Max (V <sub>INA</sub> , V <sub>INB</sub> , V <sub>OUTA</sub> , V <sub>OUTB</sub> )	●		2.45	V	
	UVLO Turn-Off Falling Threshold	Max (V <sub>INA</sub> , V <sub>INB</sub> , V <sub>OUTA</sub> , V <sub>OUTB</sub> )	●	1.7		V	
I <sub>QF</sub>	Quiescent Current in Forward Regulation, Measured via GND	V <sub>INA</sub> = 3.6V, I <sub>INA</sub> = 100mA, V <sub>INB</sub> = 0V, I <sub>INB</sub> = 0mA (Note 3)	●	40	58	μA	
I <sub>QRIN</sub>	Current Drawn from or Sourced into IN When V <sub>OUT</sub> is Greater than V <sub>IN</sub>	V <sub>IN</sub> = 3.6V, V <sub>OUT</sub> = 5.5V (Note 6)	●	-1	2.5	4.5	μA
I <sub>QRGND</sub>	Quiescent Current While in Reverse Turn-Off, Measured via GND	V <sub>INA</sub> = V <sub>INB</sub> = 0V, V <sub>OUTB</sub> = V <sub>OUTA</sub> = 5.5V, V <sub>STAT</sub> = 0V		28	36	μA	

441312fd

## ELECTRICAL CHARACTERISTICS

The ● denotes the specifications which apply over the full operating temperature range, otherwise specifications are at  $T_A = 25^\circ\text{C}$ . (Notes 2, 6)

SYMBOL	PARAMETER	CONDITIONS		MIN	TYP	MAX	UNITS
$I_{QROUTB}$	Quiescent Current While in Reverse Turn-Off. Current Drawn from $V_{OUTA}$ When OUTB Supplies Chip Power	$V_{INA} = V_{INB} = 0\text{V}$ , $V_{OUTA} = 3.6\text{V}$ , $V_{OUTB} = 5.5\text{V}$	●		3.5	6.5	$\mu\text{A}$
$I_{QOFF}$	Quiescent Current with Both ENBA and ENBB High	$V_{INA} = V_{INB} = 3.6\text{V}$ , $V_{ENBA} = V_{ENBB} = 1\text{V}$	●		28	38	$\mu\text{A}$
$V_{RTO}$	Reverse Turn-Off Voltage ( $V_{OUT} - V_{IN}$ )	$V_{IN} = 3.6\text{V}$	●	-5		10	mV
$V_{FWD}$	Forward Voltage Drop ( $V_{IN} - V_{OUT}$ ) at $I_{OUT} = -1\text{mA}$	$V_{IN} = 3.6\text{V}$	●		18	24	mV
$R_{FWD}$	On-Resistance, $R_{FWD}$ Regulation (Measured as $\Delta V/\Delta I$ )	$V_{IN} = 3.6\text{V}$ , $I_{OUT} = -100\text{mA}$ to $-500\text{mA}$ (Note 5)			100	140	$\text{m}\Omega$
$R_{ON}$	On-Resistance, $R_{ON}$ Regulation (Measured as $V/I$ at $I_{IN} = 1\text{A}$ )	$V_{IN} = 3.6\text{V}$ , $I_{IN} = 1\text{A}$ (Note 5)			140	200	$\text{m}\Omega$
$t_{ON}$	PowerPath Turn-On Time	$V_{IN} = 3.6\text{V}$ , from ENB Falling to $I_{OUT}$ Ramp Starting			11		$\mu\text{s}$
$t_{OFF}$	PowerPath Turn-Off Time	$V_{IN} = 3.6\text{V}$ , from ENB Rising with $I_{IN} = 100\text{mA}$ Falling to $0\text{mA}$			2		$\mu\text{s}$

### Short-Circuit Response

$I_{OC}$	Current Limit	$V_{INA \text{ OR } B} = 3.6\text{V}$ (Note 5)		1.8			A
$I_{QOC}$	Quiescent Current While in Overcurrent Operation	$V_{INA \text{ OR } B} = 3.6\text{V}$ , $I_{OUT} = 1.8\text{A}$ (Note 5)			100	130	$\mu\text{A}$

### STAT Output

$I_{SOFF}$	STAT Off Current	Shut Down	●	-1	0	1	$\mu\text{A}$
$I_{SON}$	STAT Sink Current	$V_{IN} > V_{OUT}$ , $V_{CTL} < V_{IL}$ , $T_J < 135^\circ\text{C}$ , $I_{OUT} < I_{MAX}$	●	7	11	15	$\mu\text{A}$
$t_{S(ON)}$	STAT Pin Current Turn-On Time	$V_{IN} = 3.6\text{V}$ , from ENB Falling			1.8		$\mu\text{s}$
$t_{S(OFF)}$	STAT Pin Current Turn-Off Time	$V_{IN} = 3.6\text{V}$ , from ENB Rising			0.8		$\mu\text{s}$

### ENB Inputs

$V_{ENBIH}$	ENB Inputs Rising Threshold Voltage	$V_{ENB}$ Rising	●		540	600	mV
$V_{ENBIL}$	ENB Inputs Falling Threshold Voltage	$V_{ENB}$ Falling	●	400	460		mV
$V_{ENBHYST}$	ENB Input Hysteresis	$V_{ENBHYST} = (V_{ENBIH} - V_{ENBIL})$			90		mV
$I_{ENB}$	ENB Inputs Pull-Down Current	$V_{OUT} < V_{IN} = 3.6\text{V}$ , $V_{ENB} < V_{IL}$	●	2	3	4	$\mu\text{A}$

### OVI Input (LTC4413-2 Only)

$V_{OVIH}$	OVI Input Rising Threshold Voltage	$V_{OVI}$ Rising			5.9	6.2	V
$V_{OVIL}$	OVI Input Falling Threshold Voltage	$V_{OVI}$ Falling		5.4	5.6		V
$V_{OVID}$	OVI-OVP Voltage Drop	$V_{OVI} = 8\text{V}$ , No Load at OVP			100		mV
$I_{OVI}$	OVI Bias Current	$V_{OVI} = 8\text{V}$			80		$\mu\text{A}$

**Note 1:** Stresses beyond those listed under Absolute Maximum Ratings may cause permanent damage to the device. Exposure to any Absolute Maximum Rating condition for extended periods may affect device reliability and lifetime.

**Note 2:** The LTC4413-1/LTC4413-2 are guaranteed to meet performance specifications from  $0^\circ\text{C}$  to  $85^\circ\text{C}$ . Specifications over the  $-40^\circ\text{C}$  to  $85^\circ\text{C}$  operating temperature range are assured by design, characterization and correlation with statistical process controls.

**Note 3:** Quiescent current increases with diode current: refer to plot of  $I_{QF}$  vs  $I_{OUT}$ .

**Note 4:** This IC includes overtemperature protection that is intended to protect the device during momentary overload conditions. Overtemperature protection will become active at a junction temperature greater than the maximum operating temperature. Continuous operation above the specified maximum operating junction temperature may impair device reliability.

**Note 5:** Specification is guaranteed by correlation to wafer-level measurements.

**Note 6:** Unless otherwise specified, current into a pin is positive and current out of a pin is negative. All voltages referenced to GND.

## TYPICAL PERFORMANCE CHARACTERISTICS

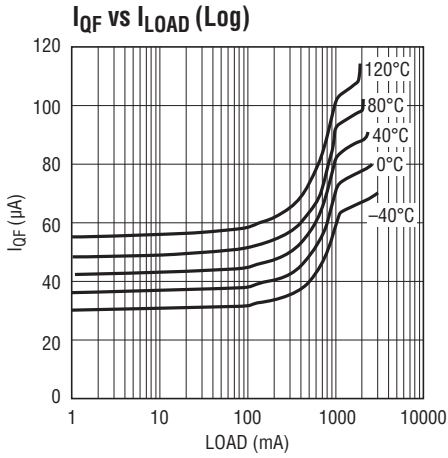

441312 G01

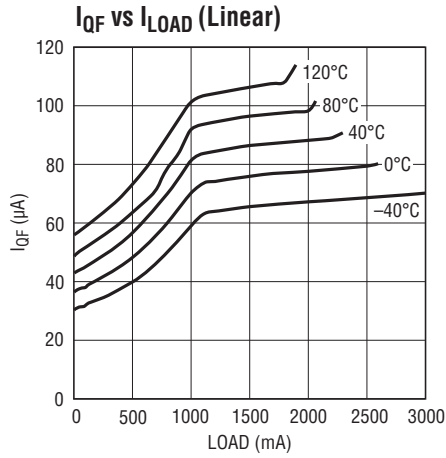

441312 G02

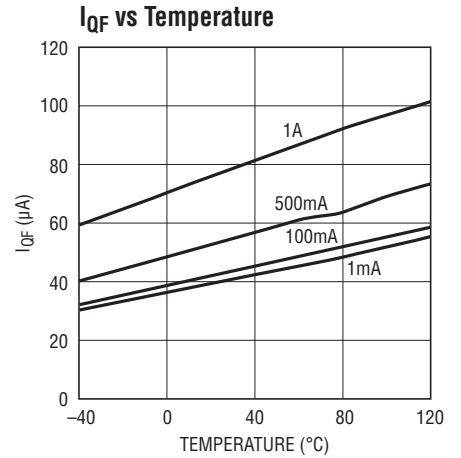

441312 G03

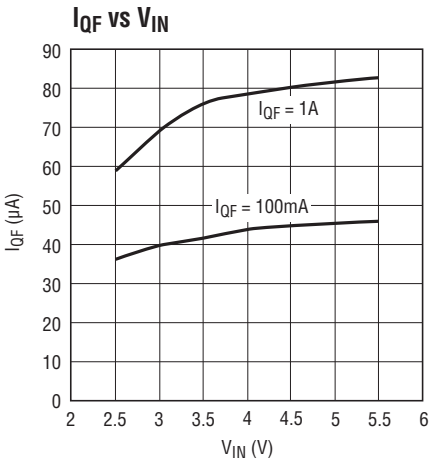

441312 G04

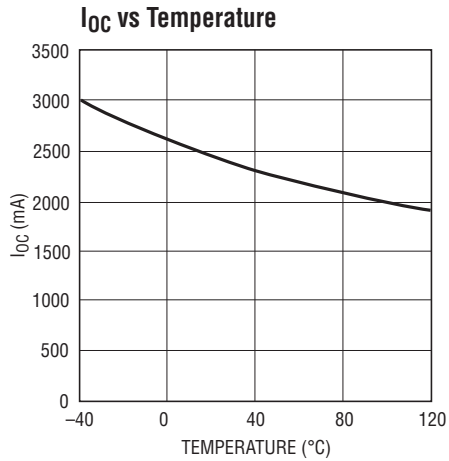

441312 G05

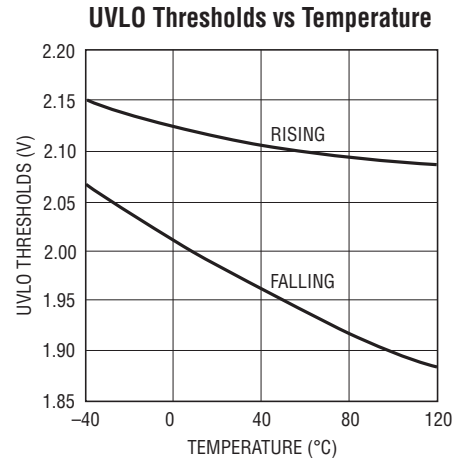

441312 G06

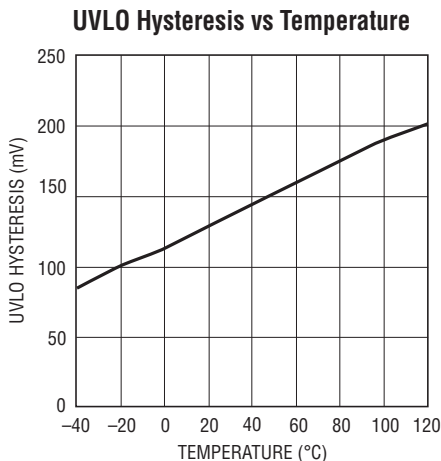

441312 G07

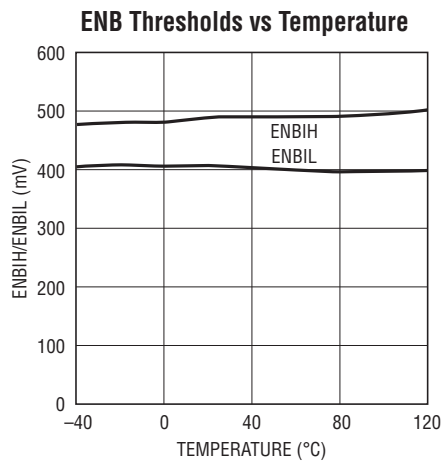

441312 G08

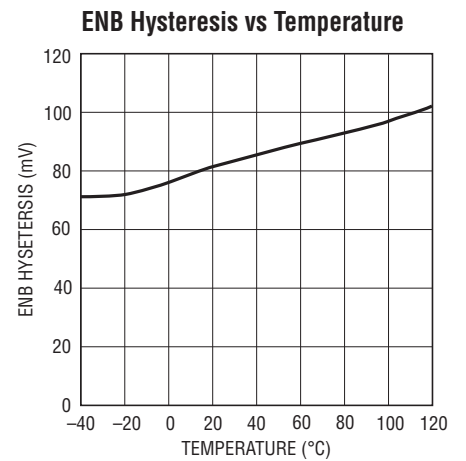

441312 G09

# TYPICAL PERFORMANCE CHARACTERISTICS

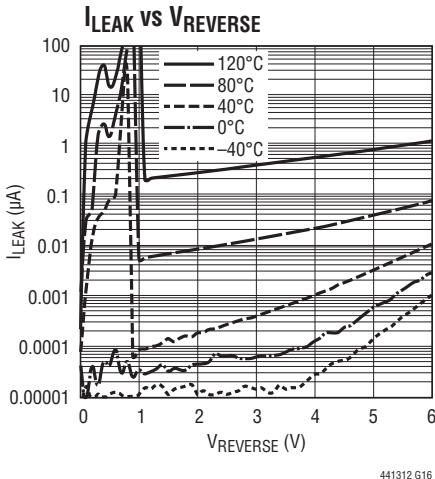
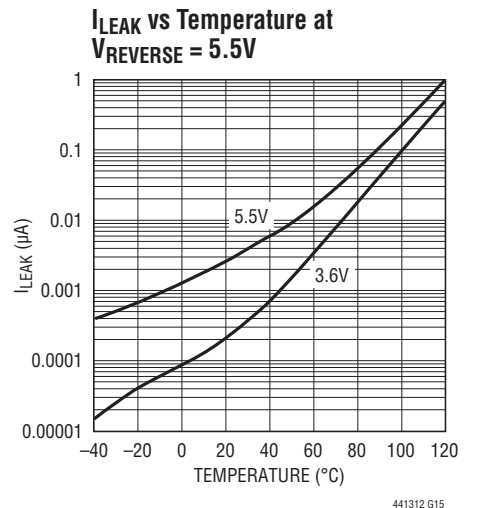
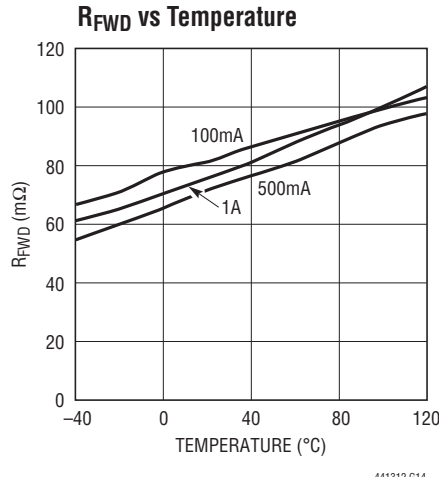
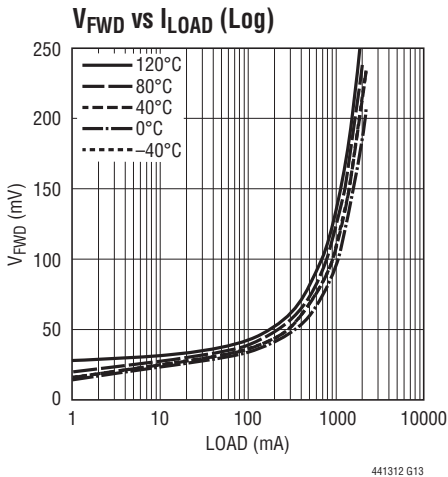
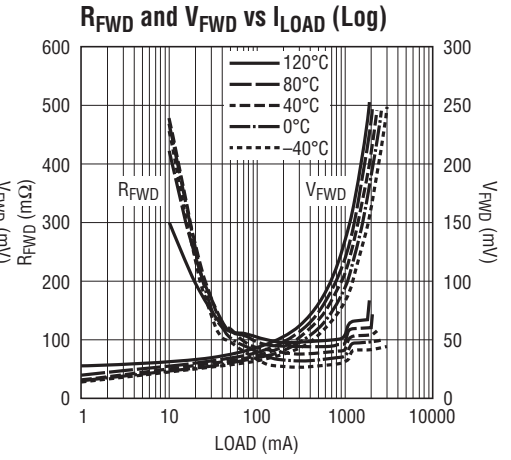
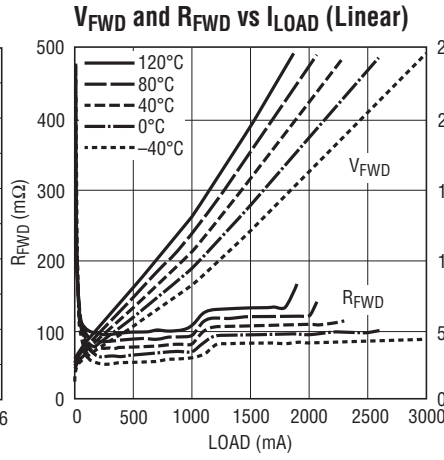
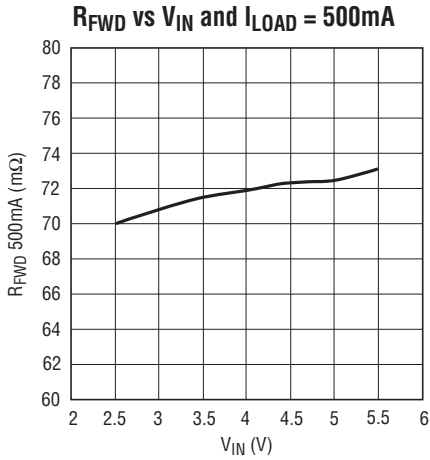

**Response to 800mA Load Step in <16μs**

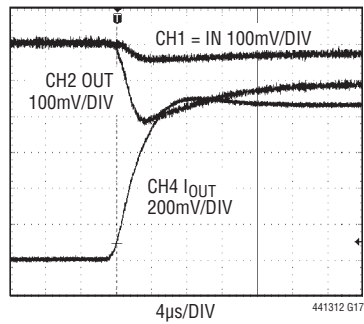

**ENB Turn-On, 30μs to Turn On with 180mA Load**

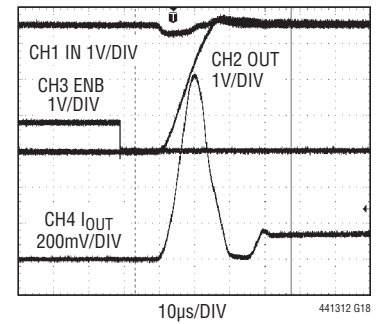

## TYPICAL PERFORMANCE CHARACTERISTICS

**ENB Turn-Off, 2 $\mu$ s to Disconnect IN from 180mA Load**

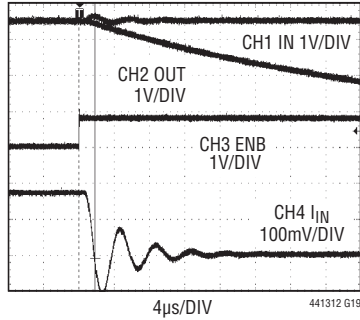

**Efficiency vs Load Current**

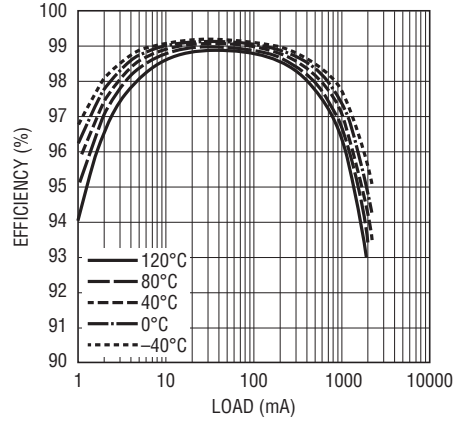

**Power Loss vs Load Current**

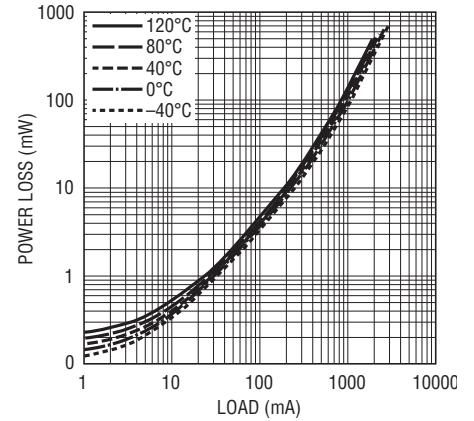

**Overvoltage Thresholds vs Temperature (LTC4413-2 Only)**

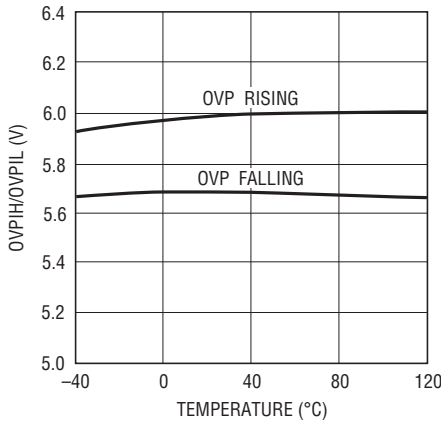

**Overvoltage Hysteresis vs Temperature (LTC4413-2 Only)**

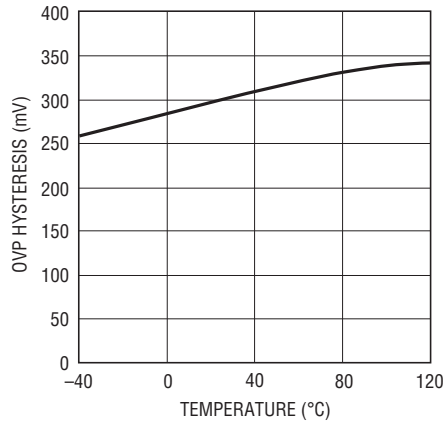

**OVI Current vs Voltage (LTC4413-2 Only)**

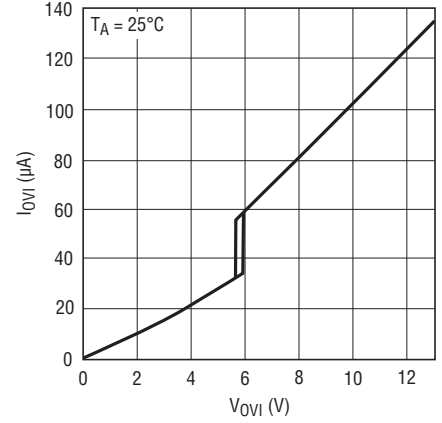

**OVI-OVP Voltage Drop vs OVI Voltage (LTC4413-2 Only)**

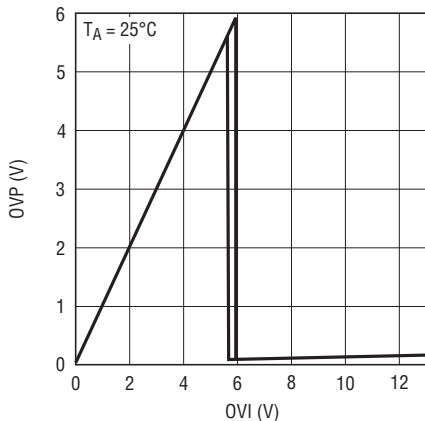

**I<sub>Q</sub> OVI vs Temperature (LTC4413-2 Only)**

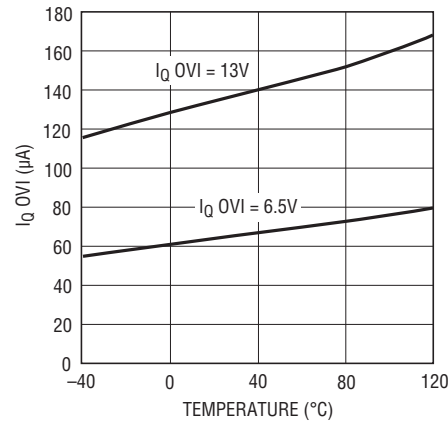

**OVI-OVP vs Temperature (LTC4413-2 Only)**

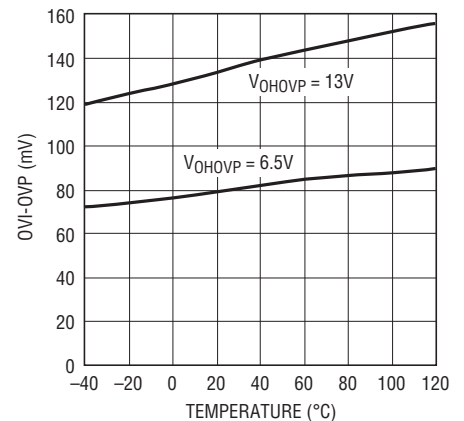

## PIN FUNCTIONS

**INA (Pin 1):** Primary Ideal Diode Anode and Positive Power Supply for LTC4413-1/LTC4413-2. Bypass INA with a ceramic capacitor of at least 1 $\mu$ F. (Series 1 $\Omega$  snub resistors and higher valued capacitances are recommended when large inductances are in series with this input.) This pin can be grounded when not used. Limit slew rate on this pin to less than 2.5V/ $\mu$ s.

**ENBA (Pin 2):** Enable Low for Diode A. Pull this pin high to shut down this power path. Tie to GND to enable. Refer to Table 1 for mode control functionality. This pin can be left floating, a weak (3.5 $\mu$ A) pull-down internal to LTC4413-1/LTC4413-2 is included.

**GND (Pin 3):** Power Ground for the IC.

**ENBB (Pin 4):** Enable Low for Diode B. Pull this pin high to shut down this power path. Tie to GND to enable. Refer to Table 1 for mode control functionality. This pin can be left floating, a weak (3.5 $\mu$ A) pull-down internal to LTC4413-1/LTC4413-2 is included.

**INB (Pin 5):** Secondary Ideal Diode Anode and Positive Power Supply for LTC4413-1/LTC4413-2. Bypass INB with a ceramic capacitor of at least 1 $\mu$ F. (Series 1 $\Omega$  snub resistors and higher valued capacitances are recommended when large inductances are in series with this input.) This pin can be grounded when not used. Limit slew rate on this pin to less than 2.5V/ $\mu$ s.

**OUTB (Pin 6):** Secondary Ideal Diode Cathode and Output of the LTC4413-1/LTC4413-2. Bypass OUTB with a high (1m $\Omega$  min) ESR ceramic capacitor of at least 4.7 $\mu$ F. This pin must be left floating when not in use. Limit slew rate on this pin to less than 2.5V/ $\mu$ s.

**OVP (Pin 7, LTC4413-2 Only):** Drive Output for an External OVP Switch PMOS Transistor (To Inhibit Overvoltage Wall Adapter Voltages from Damaging Device.) During overvoltage conditions, this output will remain high so long as an overvoltage condition persists. This pin must be left floating when not in use.

**OVI (Pin 8, LTC4413-2 Only):** Sense Input for Overvoltage Protection Block. This pin can be left floating or grounded when not used.

**STAT (Pin 9):** Status Condition Indicator. Weak (11 $\mu$ A) pull-down current output. When terminated, high indicates diode conducting. Refer to Table 2 for the operation of this pin. This pin can also be left floating or grounded.

**OUTA (Pin 10):** Primary Ideal Diode Cathode and Output of the LTC4413-1/LTC4413-2. Bypass OUTA with a high (1m $\Omega$  min) ESR ceramic capacitor of at least 4.7 $\mu$ F. This pin must be left floating when not in use. Limit slew rate on this pin to less than 2.5V/ $\mu$ s.

**Exposed Pad (Pin 11):** Signal Ground. This pin must be soldered to PCB ground to provide both electrical contact to ground and good thermal contact to PCB.

**BLOCK DIAGRAM**

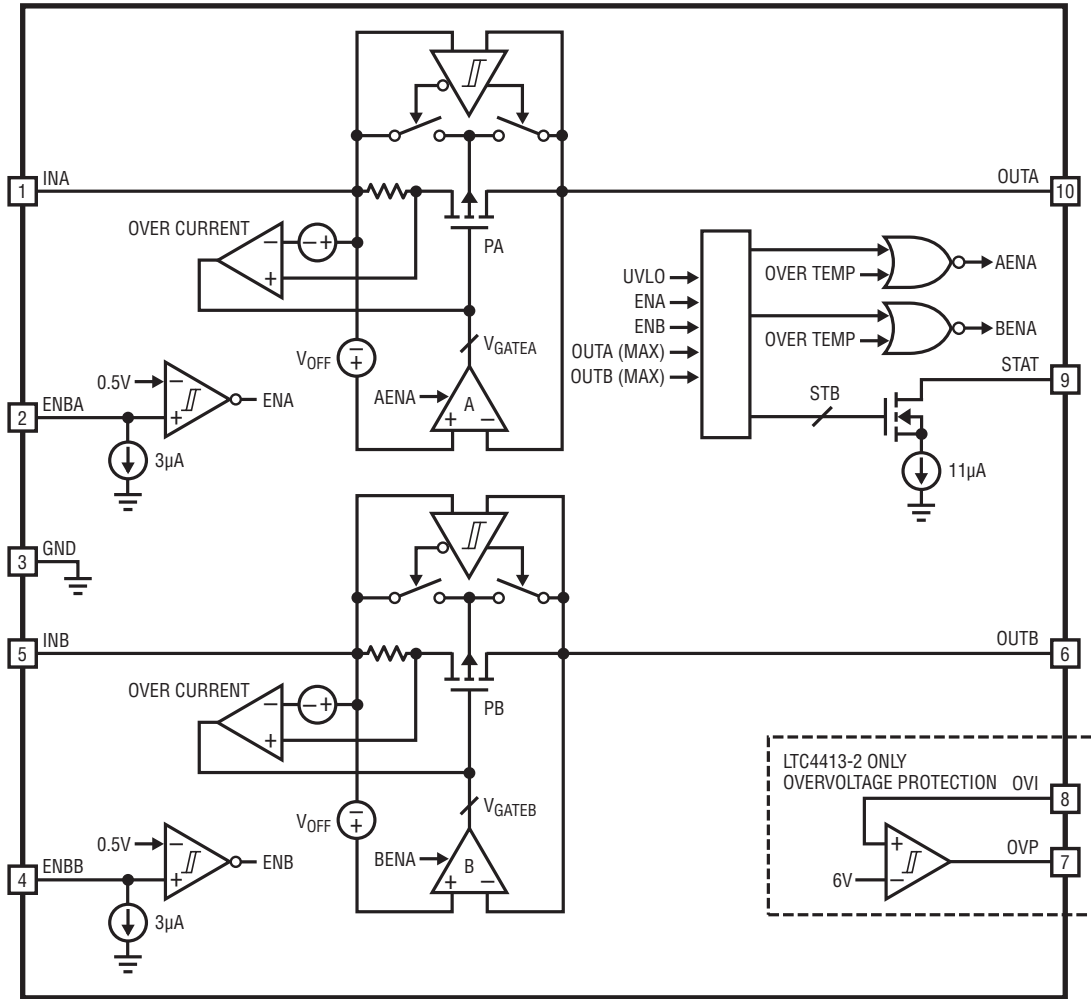

441312 BD

## OPERATION

The LTC4413-1/LTC4413-2 are described with the aid of the Block Diagram. Operation begins when the power source at  $V_{INA}$  or  $V_{INB}$  rises above the undervoltage lockout (UVLO) voltage of 2.4V and the corresponding control pin ENBA or ENBB is low. If only the voltage at the  $V_{INA}$  pin is present, the internal power source ( $V_{DD}$ ) is supplied from the  $V_{INA}$  pin. The amplifier (A) pulls a current proportional to the difference between  $V_{INA}$  and  $V_{OUTA}$  from the gate ( $V_{GATEA}$ ) of the internal PFET (PA), driving this gate voltage below  $V_{INA}$ . This turns on PA. As  $V_{OUTA}$  pulls up to a forward voltage drop ( $V_{FWD}$ ) of 15mV below  $V_{INA}$ , the LTC4413 regulates  $V_{GATEA}$  to maintain the small forward voltage drop. The system is now in forward regulation and the load at  $V_{OUTA}$  is powered from the supply at  $V_{INA}$ . As the load current varies,  $V_{GATEA}$  is controlled to maintain  $V_{FWD}$  until the load current exceeds the transistor's (PA) ability to deliver the current as  $V_{GATEA}$  approaches GND. At this point, the PFET behaves as a fixed resistor,  $R_{ON}$ , whereby the forward voltage increases slightly with increased load current. As the magnitude of  $I_{OUT}$  increases further, (such that  $I_{LOAD} > I_{OC}$ ) the LTC4413-1/LTC4413-2 fixes the load current to the constant value  $I_{OC}$  to protect the device. The characteristics for parameters  $R_{FWD}$ ,  $R_{ON}$ ,  $V_{FWD}$  and  $I_{OC}$  are specified with the aid of Figure 1, illustrating the LTC4413-1/LTC4413-2 forward voltage drop versus that of a Schottky.

If another supply is provided at  $V_{INB}$ , the LTC4413-1/LTC4413-2 likewise regulate the gate voltage on PB to

maintain the output voltage,  $V_{OUTB}$ , just below the input voltage  $V_{INB}$ . If this alternate supply,  $V_{INB}$ , exceeds the voltage at  $V_{INA}$ , the LTC4413-1/LTC4413-2 selects this input voltage as the internal supply ( $V_{DD}$ ). This second ideal diode operates independently of the first ideal diode function.

When an alternate power source is connected to the load at  $V_{OUTA}$  (or  $V_{OUTB}$ ), the LTC4413-1/LTC4413-2 sense the increased voltage at  $V_{OUTA}$ , and amplifier A increases the voltage  $V_{GATEA}$ , reducing the current through PA. When  $V_{OUTA}$  is higher than  $V_{INA} + V_{RTO}$ ,  $V_{GATEA}$  will be pulled up to  $V_{DD}$ , turning off PA. The internal power source for the LTC4413-1/LTC4413-2 ( $V_{DD}$ ) then diverts to draw current from the  $V_{OUTA}$  pin, only if  $V_{OUTA}$  is larger than  $V_{INB}$  (or  $V_{OUTB}$ ). The system is now in the reverse turn-off mode. Power to the load is being delivered from an alternate supply, and only a small current ( $I_{LEAK}$ ) is drawn from or sourced to  $V_{INA}$  to sense the potential at  $V_{INA}$ .

When the selected channel of the LTC4413-1/LTC4413-2 is in reverse turn-off mode or both channels are disabled, the STAT pin sinks 11 $\mu$ A of current ( $I_{SON}$ ) if connected.

Channel selection is accomplished using the two ENB pins, ENBA and ENBB. When the ENBA input is asserted (high), PA has its gate voltage pulled to  $V_{DD}$ , turning off PA. A 3.5 $\mu$ A pull-down current on the ENB pins ensures a low level at these inputs if left floating.

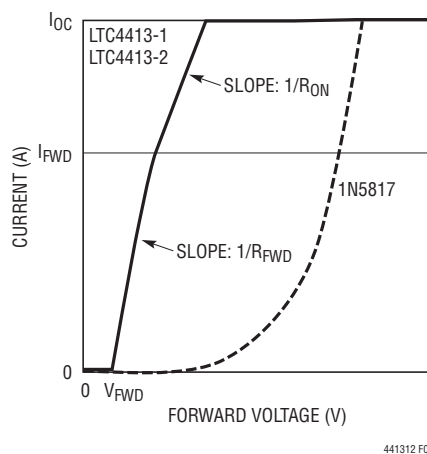

Figure 1. The LTC4413 vs the 1N5817

## OPERATION

### Overcurrent and Short-Circuit Protection

During an overcurrent condition, the output voltage droops as the load current exceeds the amount of current that the LTC4413-1/LTC4413-2 can supply. At the time when an overcurrent condition is first detected, the LTC4413-1/LTC4413-2 take some time to detect this condition before reducing the current to  $I_{OC}$ . For short durations after the output is shorted, until TOC, the current may exceed  $I_{OC}$ . The magnitude of this peak short-circuit current can be large depending on the load current immediately before the short-circuit occurs. During overcurrent operation, the power consumption of the LTC4413-1/LTC4413-2 is large, and is likely to cause an overtemperature condition as the internal die temperature exceeds the thermal shutdown temperature.

### Overtemperature Protection

The overtemperature condition is detected when the internal die temperature increases beyond 150°C. An overtemperature condition will cause the gate amplifiers (A and B) as well as the two P-channel MOSFETs (PA and PB) to shut off. When the internal die temperature cools to below 140°C, the amplifiers turn on and the LTC4413-1/LTC4413-2 reverts to normal operation. Note that prolonged operation under overtemperature conditions degrades reliability.

### Overvoltage Protection (LTC4413-2 Only)

An overvoltage condition is detected whenever the overvoltage input (OVI) pin is pulled above 6V. The condition persists until the OVI voltage falls below 5.6V. The overvoltage protection (OVP) output is low unless an overvoltage condition is detected. If an overvoltage condition is present, the OVP output is pulled up to the voltage applied to the OVI input. This output signal can be used to enable or disable an external PFET that is placed between the input that is the source of the excessive voltage and the input to the LTC4413-2, thus eliminating the potential damage that may occur to the LTC4413-2 if its input voltage exceeds the absolute maximum voltage of 6V. See the Applications Information section *Dual Battery Load Sharing with Automatic Switchover to a Wall Adapter with*

*Overvoltage Protection* for more information on using the overvoltage protection function within the LTC4413-2.

### Channel Selection and Status Output

Two active-high control pins independently turn off the two ideal diodes contained within the LTC4413-1/LTC4413-2, controlling the operation mode as described by Table 1. When the selected channel is reverse biased, or the LTC4413-1/LTC4413-2 is put into low power standby, the status signal indicates this condition with a low voltage.

**Table 1. Mode Control**

ENB1	ENB2	STATE
Low	Low	Diode'OR NB: The Two Outputs are not Connected Internal to the Device
Low	High	Diode A = ENABLED, Diode B = DISABLED
High	Low	Diode A = DISABLED, Diode B = ENABLED
High	High	All Off (Low Power Standby)

The function of the STAT pin depends on the mode that has been selected. Table 2 describes the STAT pin output current, as a function of the mode selected as well as the conduction state of the two diodes.

**Table 2. STAT Output Pin Function**

ENB1	ENB2	CONDITIONS	STAT
Low	Low	Diode A Forward Bias, Diode B Forward Bias	$I_{SNK} = 0\mu A$
		Diode A Forward Bias, Diode B Reverse Bias	$I_{SNK} = 0\mu A$
		Diode A Reverse Bias, Diode B Forward Bias	$I_{SNK} = 11\mu A$
		Diode A Reverse Bias, Diode B Reverse Bias	$I_{SNK} = 11\mu A$
Low	High	Diode A Forward Bias, Diode B Disabled	$I_{SNK} = 0\mu A$
		Diode A Reverse Bias, Diode B Disabled	$I_{SNK} = 11\mu A$
High	Low	Diode A Disabled, Diode B Forward Bias	$I_{SNK} = 0\mu A$
		Diode A Disabled, Diode B Reverse Bias	$I_{SNK} = 11\mu A$
High	High	Diode A Disabled, Diode B Disabled	$I_{SNK} = 11\mu A$

## APPLICATIONS INFORMATION

### Introduction

The LTC4413-1/LTC4413-2 are intended for power control applications that include low loss diode OR'ing, fully automatic switchover from a primary to an auxiliary source of power, microcontroller controlled switchover from a primary to an auxiliary source of power, load sharing between two or more batteries, charging of multiple batteries from a single charger and high side power switching.

### Dual Battery Load Sharing with Automatic Switchover to a Wall Adapter with Overvoltage Protection (LTC4413-2 Only)

An application circuit for dual battery load sharing with automatic switchover of load from batteries to a wall adapter is shown in Figure 2. When the wall adapter is not present, whichever battery has the higher voltage provides the load current until it has discharged to the voltage of the other battery. The load is shared between the two batteries according to the capacity of each battery. The higher capacity battery provides proportionally higher current to the load. When a wall adapter input is applied, the output voltage rises as the body diode in MP2 conducts. When the output voltage is larger than the battery voltages, the LTC4413 turns off and very little load current is drawn from the batteries. At this time, the STAT pin pulls down

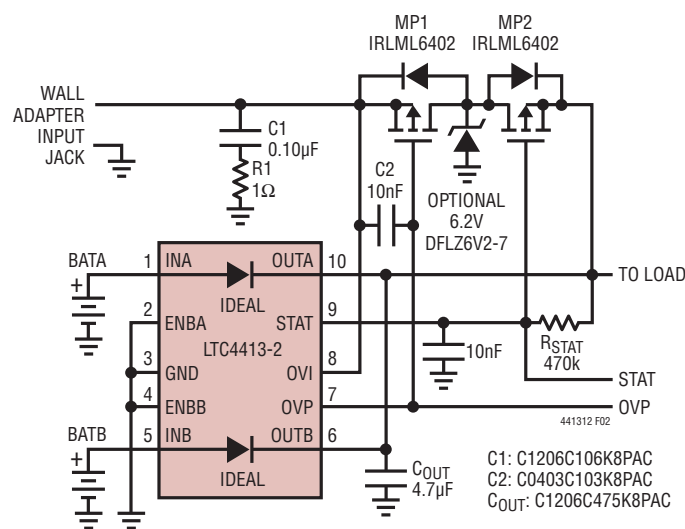

Figure 2

the gate voltage of MP2, causing it to conduct. This status signal can be used to provide information as to whether the wall adapter (or BATB) is supplying the load current. If the wall adapter voltage exceeds the OVI trip threshold ( $V_{OVIH}$ ) then the wall adapter is disconnected via the external PFET, MP1. The OVI voltage can be monitored (through a voltage divider if necessary) to determine if an overvoltage condition is present.

Capacitor C2 is required to dynamically pull up on the gate of PFET MP1 if a fast edge occurs at the wall adapter input during a hot plug. In the event that capacitor C2 (or the gate-to-source of MP1) is precharged below the OVI rising threshold. When a high voltage spike occurs, the OVP output cannot guarantee turning off MP1 before the load voltage exceeds the absolute maximum voltage for the LTC4413-2. This may occur in the event that the wall adapter suddenly steps from 5.5V to a much higher value. In this case, a Zener diode is recommended to keep the output voltage to a safe level.

### Automatic PowerPath Control

Figure 3 illustrates an application circuit for microcontroller monitoring and control of two power sources. The microcontroller's analog inputs (perhaps with the aid of a resistor voltage divider) monitor each supply input and the LTC4413-1 status, and then commands the LTC4413-1 through the two ENBA/ENBB control inputs.

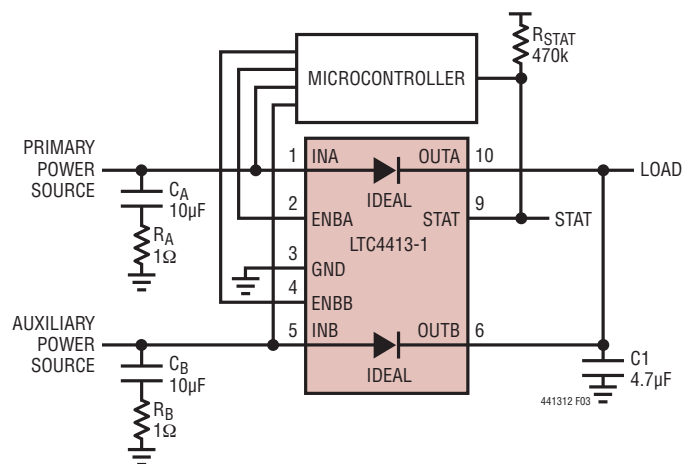

Figure 3

## APPLICATIONS INFORMATION

### Automatic Switchover from a Battery to an Auxiliary Supply, or a Wall Adapter with Overvoltage Protection

Figure 4 illustrates an application circuit where the LTC4413-2 is used to automatically switch over between a battery, an auxiliary power supply and a wall adapter. When the battery is supplying load current, OVP is at GND and STAT is high. If a higher supply is applied to AUX, the BAT will be disconnected from the load and the load is powered from AUX. When a wall adapter is applied, the body diode of MP2 forward biases. When the load voltage exceeds the AUX (or BAT) voltage, the LTC4413-2 senses this higher voltage and disconnects AUX (or BAT) from the load. At the same time it pulls the STAT voltage to GND, thereby turning on MP2. The load current is now supplied from the wall adapter. If the wall adapter voltage exceeds the OVI rising threshold, the OVP voltage rises and turns off MP1, disconnecting the wall adapter from the load. The output voltage collapses down to the AUX (or BAT) voltage and the LTC4413-2 reconnects the load to AUX (or BAT).

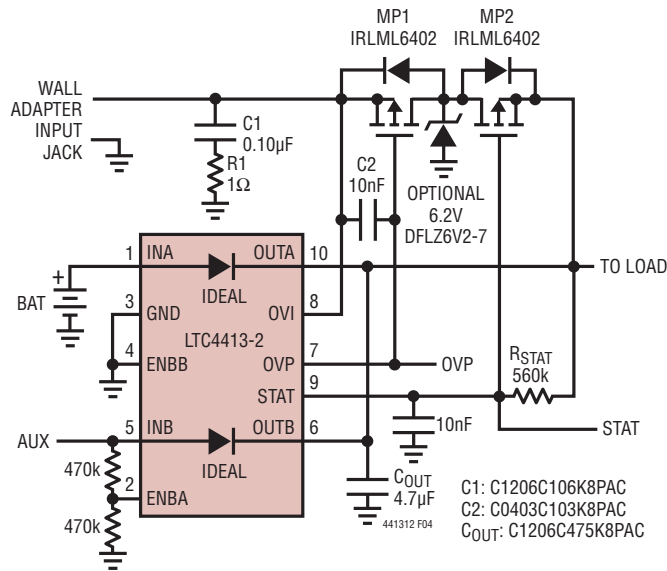

Figure 4

Capacitor C2 is required to dynamically pull up on the gate of MP1 if a fast edge occurs at the wall adapter input during a hot plug. If the wall adapter voltage is precharged when an overvoltage spike occurs, the OVP voltage may not discharge capacitor C2 in time to protect the output. In this event, a Zener diode is recommended to protect the output node until MP1 is turned off.

### Multiple Battery Charging

Figure 5 illustrates an application circuit for automatic dual battery charging from a single charger. Whichever battery has the lower voltage will receive the larger charging current until both battery voltages are equal, then both are charged. While both batteries are charging simultaneously, the higher capacity battery gets proportionally higher current from the charger. For Li-Ion batteries, both batteries achieve the float voltage minus the forward regulation voltage of 15mV. This concept can apply to more than two batteries. The STAT pin provides information as to when the battery at OUTA is being charged. For intelligent control, the ENBA/ENBB input pins can be used with a microcontroller as shown in Figure 3.

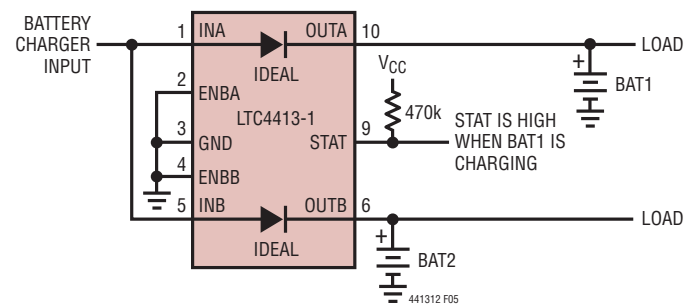

Figure 5

## APPLICATIONS INFORMATION

### Automatic Switchover from a Battery to a Wall Adapter and Charger with Overvoltage Protection

Figure 6 illustrates the LTC4413-2 performing the function of automatically switching a load over from a battery to a wall adapter while controlling an LTC4059 battery charger. When no wall adapter is present, the LTC4413-2 connects the load at OUTA from the Li-Ion battery at INA. In this condition, the STAT voltage is high, thereby disabling the battery charger. If a wall adapter of a higher voltage than the battery is connected to MP1 (but below the OVI threshold), the load voltage rises as the second ideal diode conducts. As soon as the OUTA voltage exceeds the INA voltage, the BAT is disconnected from the load and the STAT voltage falls, turning on the LTC4059 battery charger and beginning a charge cycle. If a high voltage wall adapter is inadvertently attached above the OVI rising

threshold, the OVP pin voltage rises, disconnecting both the LTC4413-2 and the LTC4059 from potentially hazardous voltages. When this occurs, the load voltage collapses until it is below the BAT voltage causing the STAT voltage to rise, disabling the battery charger. At the same time, the LTC4413-2 automatically reconnects the battery to the load. One major benefit of this circuit is that when a wall adapter is present, the user may remove the battery and replace it without disrupting the load.

Capacitor C2 is required to dynamically pull up on the gate of MP1 if a fast edge occurs at the wall adapter input during a hot plug. If the wall adapter voltage is precharged when an overvoltage spike occurs, the OVP voltage may not discharge capacitor C2 in time to protect the output. In this event, a Zener diode is recommended to protect the output node until MP1 is turned off.

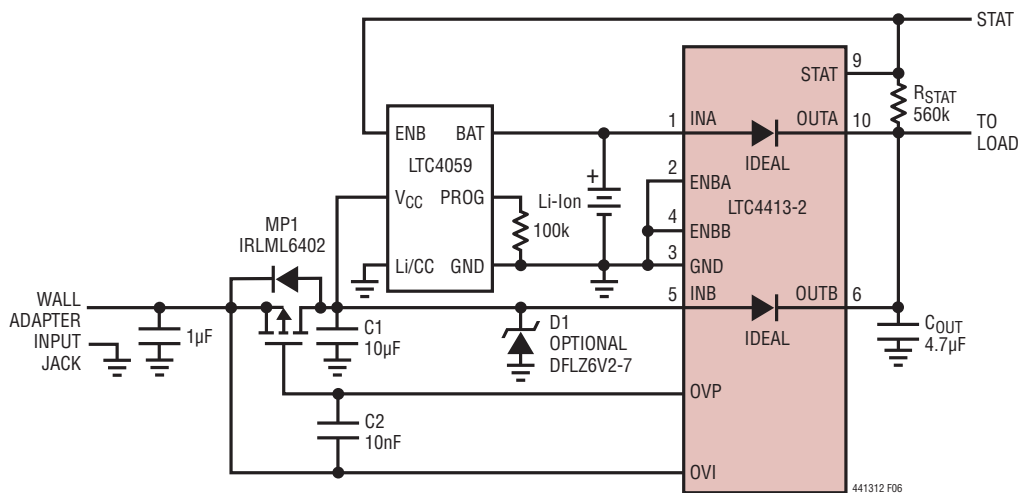

Figure 6

## APPLICATIONS INFORMATION

### Soft-Start Overvoltage Protection

In the event that a low power external PFET is used for the external overvoltage protection device, care must be taken to limit the power dissipation in the external PFET. The operation of this circuit is identical to the “Automatic Switchover from a Battery to a Wall Adapter” application shown on the first page of this data sheet. Here, however, the ideal diode from INA to INB is disabled by pulling up on ENBA whenever an overvoltage condition is detected. This channel is turned-off using a resistor connected to OVP along with a 5.6V Zener diode, ensuring the absolute maximum voltage at ENBA is not exceeded during

an overvoltage event. When the overvoltage condition ends, the OVP voltage drops slowly, depending on the gate charge of the external PFET. This causes the external PFET to linger in a high  $R_{DS(ON)}$  region where it can dissipate a significant amount of heat depending on the load current. To avoid dissipating heat in the external PFET, this application delays turning on the ideal diode from INA to OUTA, until the gate voltage of the external PFET drops below  $V_{ENBIL}$ , where the external PFET should safely be out of the high  $R_{DS(ON)}$  region. This soft-start scheme can be used on either channel of the LTC4413-2.

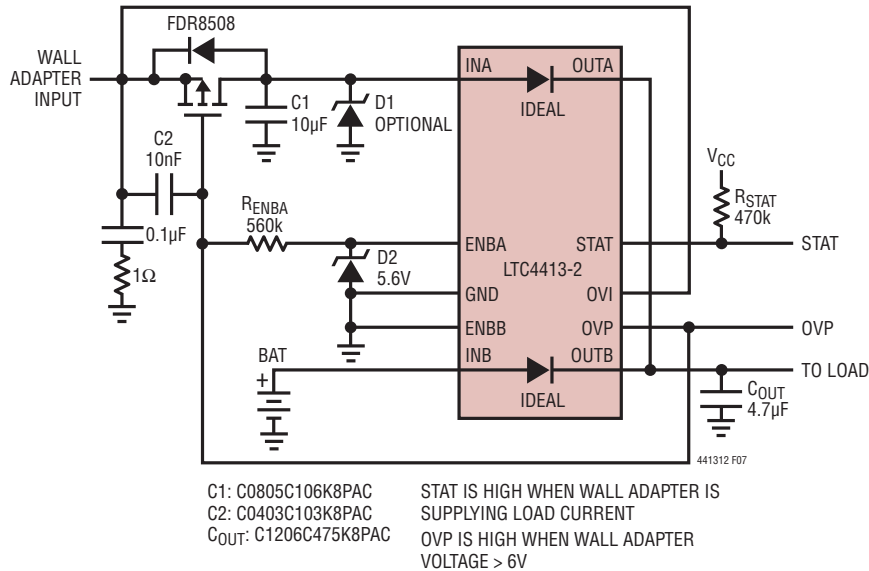

Figure 7



# LTC4413-1/LTC4413-2

## TYPICAL APPLICATION

### Automatic Switchover from a Battery to a Wall Adapter with Soft-Start Overvoltage Protection

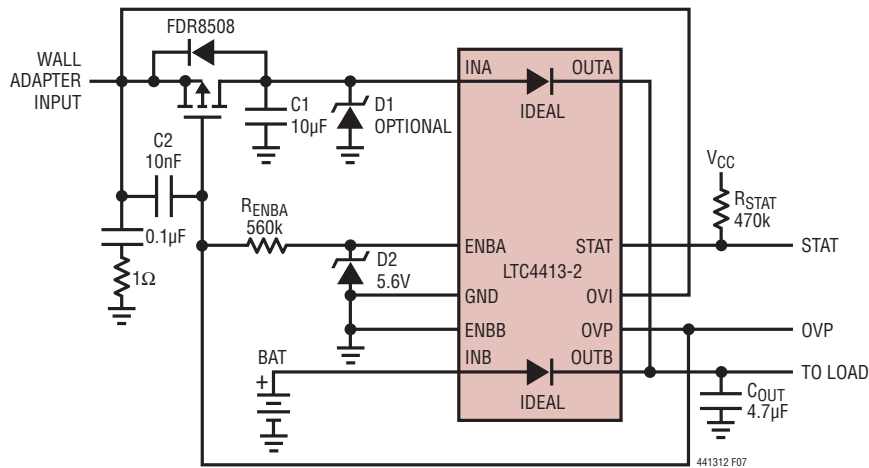

C1: C0805C106K8PAC  
 C2: C0403C103K8PAC  
 C<sub>OUT</sub>: C1206C475K8PAC

STAT IS HIGH WHEN WALL ADAPTER IS SUPPLYING LOAD CURRENT  
 OVP IS HIGH WHEN WALL ADAPTER VOLTAGE > 6V

## RELATED PARTS

PART NUMBER	DESCRIPTION	COMMENTS
LTC1558/LTC1559	Backup Battery Controller with Programmable Output	Adjustable Backup Voltage from 1.2V NiCd Button Cell, Includes Boost Converter
LTC1998	2.5µA, 1% Accurate Programmable Battery Detector	Adjustable Trip Voltage/Hysteresis, ThinSOT™
LTC4054	800mA Standalone Linear Li-Ion Battery Charger with Thermal Regulation in ThinSOT	No External MOSFET, Sense Resistor or Blocking Diode Required, Charge Current Monitor for Gas Guaging, C/10 Charge Termination
LTC4350	Hot Swappable Load Share Controller	Allows N + 1 Redundant Supply, Equally Loads Multiple Power Supplies Connected in Parallel
LTC4411	2.6A Low Loss Ideal Diode in ThinSOT	No External MOSFET, Automatic Switching Between DC Sources, Simplified Load Sharing
LTC4412/LTC4412HV	PowerPath Controller in ThinSOT	More Efficient than Diode OR'ing, Automatic Switching Between DC Sources, Simplified Load Sharing, 3V ≤ V <sub>IN</sub> ≤ 28V, 3V ≤ V <sub>IN</sub> ≤ 36V (HV)
LTC4413	Dual 2.6A, 2.5V to 5.5V, Ideal Diodes in 3mm × 3mm DFN	Lower Quiescent Current with Slower Response Time
LTC4414	36V, Low Loss PowerPath Controller for Large PFETs	Drives Large Q <sub>G</sub> PFETs, Very Low Loss Replacement for Power Supply O'Ring Diodes, 3.5V to 36V AC/DC Adapter Voltage Range, 8-Lead MSOP Package

ThinSOT is a trademark of Linear Technology Corporation.